

Astroengineering Technologies LLC
Unitsky String Technologies Inc.

**NON-ROCKET
NEAR SPACE INDUSTRIALIZATION:
PROBLEMS, IDEAS, PROJECTS**

Collection of Articles
of the VI International Scientific and Technical Conference
(October 7–8, 2023, Maryina Gorka)

Minsk
StroyMediaProject
2024

Anatoli Unitsky

An author of the fundamental EcoSpace program, the Chief Investor and Chairman of the Organizing Committee of the International Scientific and Technical Conference “Non-Rocket Near Space Industrialization: Problems, Ideas, Projects”

A scientist, engineer and visionary who devoted more than 50 years to preventing global ecological disaster and preserving the environment for future generations; he developed unique ground (Unitsky String Transport – uST) and geocosmic (General Planetary Vehicle – GPV) transport as well as eco-friendly engineering technologies and biotechnologies.

A businessman who has built a powerful engineering corporation with offices in Belarus, Russia and the United Arab Emirates. Anatoli Unitsky's team includes skilled designers, technologists, scientists and engineers – more than 1,000 specialists who have achieved significant results and succeeded in the creation and practical implementation of transport and infrastructure technologies, energy solutions, urbanism and agriculture.

The author of more than 300 scientific publications and 20 monographs, the owner of more than 200 patents and certificates for inventions, prototypes and trademarks in the construction, transport, engineering, electronic and chemical industries. Over 50 of Anatoli Unitsky's inventions are applied in production in many countries.



The anthropogenic oppression of the biosphere and the depletion of natural resources have now reached a disastrous level. If the current rate of growth and development of the technosphere persists, we risk leaving a lifeless desert unfit for existence as a legacy to our grandchildren. My EcoSpace program is justified and conceptualized in the research centers of Belarus and the UAE. By joining our efforts, we are able to refocus the Earth's technosphere on the cosmic vector of civilization development. Thus, we will eliminate the anthropogenic factor of biosphere oppression.



*Earth – for Life.
Space – for Industry.
A.U.*

Table of Contents

Welcome Speech by Anatoli Unitsky, Chief Investor, Chairman of the Organizing Committee of the VI International Scientific and Technical Conference “Non-Rocket Near Space Industrialization: Problems, Ideas, Projects”	8
Welcome Speech by H.E. Hussain Al Mahmoudi, CEO of Sharjah Research Technology and Innovation Park and American University of Sharjah Enterprises, President of West Asia and North Africa Division of the International Association of Science Parks (IASP)	12
Welcome Speech by Igor Kozhin, Head of the UNIDO Centre for International Industrial Cooperation in the Russian Federation	13
Welcome Speech by Pyotr Vityaz, Academician, Doctor of Engineering Sciences, Professor, Honored Scientist of the Republic of Belarus, Head of the Aerospace Activities Department, Deputy Head of the Space Research Agency of the National Academy of Sciences of Belarus	15
Welcome Speech by Michael Orloff, Doctor of Engineering Sciences, Professor, Founder, General Director and Scientific Supervisor of the Modern TRIZ Academy (Berlin, Germany)	18
Welcome Speech by Arseny Mitko, Corresponding Member of the Russian Academy of Natural Sciences, Ph.D. in Engineering Sciences, Associate Professor, President of the Arctic Public Academy of Sciences	19
Welcome Speech by Marina Minina, Ph.D. in Engineering Sciences, Associate Professor of the Russian Academy of National Economy and Public Administration under the President of the Russian Federation, Chairperson of the Arctic Council of the Eurasian Peoples’ Assembly, Executive Director of the “Arctic 2024” Summit	20
Welcome Speech by Andrey Fefelov, Journalist, Publicist, Editor-in-Chief of the Den-TV Channel, Deputy Editor-in-Chief of the Zavtra Newspaper	21

INGENIUM. The World as an Engineering Project	A. Unitsky	23
Global Ritual Sacrifice and Establishment of Engineering Civilization as Alternative Scenarios of the Future	A. Unitsky E. Petrov	129
Creation of Mathematical Model of the General Planetary Vehicle on the Basis of Finite Element Method	A. Unitsky A. Pakulnitski	153
Modeling the Dynamics of Magnetic System of Power Stabilizing Unit of the General Planetary Vehicle	A. Unitsky A. Khlebus	165
Providing Levitation of the General Planetary Vehicle Rotor Using Permanent Magnets	A. Unitsky S. Artyushevsky V. Looksha	179
Control Algorithms and Tests of the Prototype of Linear Electric Motor of the General Planetary Vehicle	A. Abakumov M. Zimiankou	193
General Planetary Vehicle Takeoff and Landing Complex on Oceanic Sections	A. Unitsky	205
Technology and Mechanization of Construction Process at Land Sections of the General Planetary Vehicle Equatorial Overpass	A. Unitsky D. Bochkaryov	217
Application of Classical Machine Learning and Neural Networks Training in the Diagnostics and Operation of the General Planetary Vehicle Equatorial Overpass	M. Gusev	227
High-Rise Inhabited Supports of the General Planetary Vehicle Takeoff and Landing Complex	A. Unitsky, M. Kubyshkin A. Koshelev R. Malakhau	237
Hypervelocity Tunnel of the General Planetary Vehicle Equatorial Overpass	A. Unitsky A. Shcherbich I. Dzyakau	253
Metal Foam Based Protection of the General Planetary Vehicle Body Against Meteoroids	A. Unitsky V. Ausianka	269

Use of Hydrogen-Containing Substances for Delivery of Building Materials to Near-Earth Orbit	A. Baravik V. Garanin	279	Development of Cosmetic Formulations Containing Vitamin D for Use in the EcoCosmoHouse	Y. Viaremka A. Kaliada	389
Possibility of Using Liquid Hydrogen Simultaneously as a Refrigerant and a Source of Energy for Cosmic Vehicles	A. Unitsky V. Garanin V. Yanchuk	289	Obtaining Natural Detergents from Licorice with Prebiotics in the EcoCosmoHouse Conditions	T. Tratsiakova P. Buglak N. Zyl	397
Technology of the Construction Material Production Using Household Appliances Waste	E. Zimina N. Ulyanova	301	Human Mental Adaptation in the Enclosed Ecosystem Conditions: Dynamics and Stages	I. Budrina	405
Options for Use of Electrohydraulic Discharge Equipment in the Conditions of Human Habitation in Space	A. Unitsky N. Pershai S. Arnaut	313	Structure of the Social Space of a New Type of Living Environment: Prerequisites, Development, Stratification	A. Unitsky M. Davydik	415
Technological Systems for Cultivating Plants in the EcoCosmoHouse	A. Unitsky N. Zyl D. Konyok M. Parfenchik	327	Application of Legal Norms During Construction and Operation of the General Planetary Vehicle and Its Infrastructure	A. Kazakevich	425
Humusponics as a Method of Growing Agricultural Products in the EcoCosmoHouse Conditions	A. Unitsky A. Shereshovets V. Karnei	337	Political and Legal Justification for Implementation of uSpace Geocosmic Program Within the Framework of the BRICS International Association	A. Bakhaev	433
Comparative Characteristics of Modern Technologies of Plant Cultivation in Near Space Conditions	A. Unitsky I. Demenskaya A. Kushnirenka	347	Cyberplan as a Tool for Rebooting Economy of the Union State of Russia and Belarus	A. Poteryaiko	441
Project of Creating the Enclosed Ecosystem uBioSystem for the Infinitely Long Autonomous Existence of Living Organisms	A. Unitsky A. Pauliuchenka P. Buglak I. Naletov N. Zyl P. Naumchik	359	Intercultural Communications Within the Framework of EcoSpace Program and Its Cosmic Vector – uSpace Program	D. Valynets	449
Use of Elicitors to Improve the Adaptability of Plants Under the EcoCosmoHouse Conditions	Y. Krukau V. Zayats I. Naletov	371	Resolution of the VI International Scientific and Technical Conference “Non-Rocket Near Space Industrialization: Problems, Ideas, Projects”		456
Biorecycling of Organic Residues with the Help of Microorganisms	A. Unitsky T. Pyatakova K. Boyko I. Naletov	379	Glossary: Terms and Definitions		462
			Reviews for the Collection of Articles of the VI International Scientific and Technical Conference “Non-Rocket Near Space Industrialization: Problems, Ideas, Projects”		466

Welcome Speech by Anatoli Unitsky,

Chief Investor, Chairman of the Organizing Committee
of the VI International Scientific and Technical Conference
“Non-Rocket Near Space Industrialization:
Problems, Ideas, Projects”



Dear friends, colleagues, partners, guests and participants of the VI International Scientific and Technical Conference “Non-Rocket Near Space Industrialization: Problems, Ideas, Projects”,

This year our conference is taking place within the framework of the World Space Week proclaimed by the UN. Almost all states hold events emphasizing the contribution of cosmic science and technology to the development of modern society, improvement of life of each person and the entire humankind. Today we also join the festive events.

Traditionally, the scientific forum is organized in the hospitable Aquarelle EcoPark. The place was chosen for a reason. Everyone will be able to see with their own eyes how our technologies work not on paper but in practice. Thanks to them, in just a few years the barren, ruined land of the former tank range was revived and became fertile again. Now the crops harvested here are envied by the neighboring agricultural enterprises. In this way, we prove in practice the effectiveness of our biosphere solutions, which we propose for application, including in near space by using the General Planetary Vehicle (GPV).

Nearby, in the EcoTechnoPark, five types of operating complexes of Unitsky String Transport (uST) have already been built, where we are developing string technologies,

one of which is the GPV. This means that each of our projects is scientifically substantiated and conceptually implemented by the international Unitsky Group of Companies, first of all by the head engineering company Unitsky String Technologies Inc.

The subject of our conference is very symbolic for me. As a schoolboy, in the 60s of the last century, living in Kazakhstan near the legendary Soviet Baikonur Cosmodrome, I got interested in rocket modeling. Soon, after some simple research, I realized the fundamentally unrecoverable shortcomings of the launch vehicle. It was those first experiments that formed the basis for the scientific developments of my uSpace geocosmic program and, in particular, the GPV, which we will discuss at the VI international conference.

We are voyagers in the world of science and technology, and only our determination can open the door for humankind to amazing perspectives that were not even possible yesterday. Through bold experimentation and relentless pursuit, we can break the boundaries of the known and achieve the biggest progress. Our world is already entering a new phase of civilizational development that focuses on seeking constructive cooperation among states and peoples as well as on using the most innovative engineering advances for the benefit of all of Earth's civilization.

Engineers play a key role here. They are the ones who create innovations and find solutions that move our technological civilization forward step by step. It is from the engineering blueprint that new technologies, machines, equipment and a wide variety of goods grow, which improve people's living standards, optimize production processes and accept the most complex global challenges of our time.

It was engineers who originated science and art, transport and power industry, agriculture and medicine as well as every other civilizational accomplishment. Over the millennia, from stone tools and the first human-made fire, engineering achievements have shaped our planetwide society – human civilization, which by origin should be called engineering, not technological, technocratic, technogenic or industrial, as people commonly call it.

This topic has deeply interested me and has become the subject of my research, and I will introduce their results and conclusions to you in my plenary report. Today it is extremely important to realize that it is in engineering that a balanced approach is concentrated in, which can give the one true creative direction for the further development of our civilization. After all, it is engineers who have created the civilizational world.

The most significant step in the development of human civilization will be the relocation of the Earth's industry into space with its immense resources: area, energy, raw materials and technological ones, including deep vacuum and weightlessness, which do not exist on our planet.

The complex analysis I carried out 50 years ago revealed that only the GPV can handle this task, because the rocket path of industrialization of near-Earth space, which is the ultimate dream of science fictionists and futurologists, is a utopia.

In 1977, 47 years ago, I filed my first application for the invention of the GPV. The correspondence with the USSR State Committee for Inventions and Discoveries took five years and included several volumes of comprehensive feasibility analyses and engineering calculations that I had to perform. About 500 arguments were put forward against the GPV, including, for example, “the influence of the Moon and solar wind is not taken into account” and “there is not enough metal on the planet for construction”. Although I made calculations and showed that the Moon and the Sun do not interfere with the GPV and that the Earth's industry could produce the amount of steel required for its construction in only two weeks, I was denied a patent.



I could not get my invention recognized in Russia and Belarus already in the recent history. That is why several years ago I applied for foreign patenting. I would like to inform you that just the other day I received patents valid in 38 European countries. In the near future, patents for the GPV in China and four patents in the USA will be granted.

The GPV is a unique invention, because a planet is considered to be just a structural element of a gigantic in size and unrivaled in functionality geocosmic self-supporting aircraft. The GPV will be able to operate on three types of planets:

- having, like Earth, the land;
- having, as in Stanislaw Lem's Solaris, only the ocean;
- gas giants like Saturn, which have neither ocean nor land.

We are very fortunate to live on a small planet. If Earth had the mass of Saturn, a launch vehicle would not be able to take off into outer space at all because of the high gravity and dense atmosphere in which any spacecraft would burn up at the required escape velocity of more than 25 km/s (more than 90,000 km/h). And the GPV would be able to take off from such a massive planet because it traverses the atmosphere at the speed of a car, not a rocket.

That is why the rocket cosmic vector laid out on planet Earth by our compatriots Konstantin Tsiolkovsky, Sergey Korolev and Yuri Gagarin would be excluded by the laws of physics and humankind would have to start conquering space immediately from the GPV. This is one of the main reasons why our conference is called "Non-Rocket Near Space Industrialization".

I invite the forum participants to join the roundtable discussions and actively participate in the debates. All those present here are experts, opinion leaders. During this event we will talk in detail about technological progress in various fields of science and technology and also address philosophical and social problems of society, which are inseparable from the evolution of Earth's civilization.

Together we will convey to the public that it is necessary to revise outdated foundations and take actual steps for transition to the biospheric and cosmic path of civilizational development to save humankind from degradation, extinction and death on the planet limited in size and resources, which has nurtured and raised our engineering civilization.

The prophetic words of Konstantin Tsiolkovsky will come true: "Earth is the cradle of humanity, but humankind cannot stay in the cradle forever."

I would like to conclude my welcome speech by thanking the participants and guests gathered here. I wish everyone fruitful work!

The VI International Scientific and Technical Conference "Non-Rocket Near Space Industrialization: Problems, Ideas, Projects" is declared open.



Together we will convey to the public that it is necessary to revise outdated foundations and take actual steps for transition to the biospheric and cosmic path of civilizational development to save humankind from degradation, extinction and death on the planet limited in size and resources, which has nurtured and raised our engineering civilization.

Welcome Speech by H.E. Hussain Al Mahmoudi,

CEO of Sharjah Research
Technology and Innovation Park
and American University
of Sharjah Enterprises,
President of West Asia
and North Africa Division
of the International Association
of Science Parks (IASP)



Welcome Speech by Igor Kozhin,

Head of the UNIDO Centre
for International Industrial Cooperation
in the Russian Federation



Dear guests,

On behalf of Sharjah Research Technology and Innovation Park I would like to welcome everyone to the VI International Scientific and Technical Conference "Non-Rocket Near Space Industrialization: Problems, Ideas, Projects".

This year's event comes at a critical stage where nations are competing to explore the space. Here today we gather the brightest mind, experts, scientists, entrepreneurs who are exploring this topic, sharing these practices and putting forward recommendation on how best we can explore space technologies in the more sustainable, safe, profitable manners. At this conference, we will discuss new ideas, challenges and opportunities associated with this sphere.

In the United Arab Emirates our entity is among the leaders in the space topic, whether it is an initiative about Mars and its exploration or development of human capital and advanced training of the specialists who are engaged in research of space technology, open new possibilities and educate others about this sector of the economy.

In the name and on the behalf of the Sharjah Research Technology and Innovation Park I wish you all the best and congratulate our partners – uSky Transport and Astroengineering Technologies LLC – on the fact that they have gathered us

at this historically significant conference to discuss, analyze, learn and create a global network of professional contacts.

On behalf of the UNIDO Centre for International Industrial Cooperation in the Russian Federation I welcome the participants, organizers and guests of the VI International Scientific and Technical Conference "Non-Rocket Near Space Industrialization: Problems, Ideas, Projects".

The United Nations Industrial Development Organization (UNIDO) is a specialized agency in the UN system, and our main goal is supporting of sustainable industrial development and its acceleration as well as strengthening of international cooperation and assistance in achieving the Sustainable Development Goals formulated by the UN General Assembly.

These 17 goals are call for action from all the countries (developed, developing and least developed ones), and they are aimed to improve the wellbeing of our planet and protect it. Herewith, the measures on poverty eradication should be taken in parallel with boosting economic growth, solving issues in the spheres of education, industrialization, healthcare, social welfare, climate change and environment protection.

Mr. Gerd Müller, Director General of UNIDO, stated in his report at the G20 Summit that in our world everything is connected – all states and all peoples. The world has already faced several global crises in recent years, but it is clear that

multilateral cooperation is essential. We need more solidarity. Our concepts of progress and growth should be reconsidered, alongside it is necessary to promote new innovative projects.

Ladies and gentlemen, UNIDO acts as a partner in the projects on technology and knowledge transfer and investment partnership programs. Our entity strives to support cooperation of the government and private industrial enterprises and scientific institutions in both industrialized and developing countries. Together we are able to turn global responsibility into a global solution for the benefit of all. In solidarity and cooperation, we can truly change the world and make it better!

Given our organization's mandate and a significant role of this annual conference in terms of suggested innovative approaches and technology for near space industrialization, in 2022 UNIDO Centre in Russia decided to support the organizers of the event and signed an agreement on cooperation within the EcoSpace program. We intend to develop this cooperation and are ready to discuss the opportunities for implementation of new joint projects and initiatives.

I am confident that today's event will strengthen ties between scientists and practitioners, while survey of space and the innovative projects presented here can be



Welcome Speech by Pyotr Vityaz,

Academician,
Doctor of Engineering Sciences,
Professor, Honored Scientist
of the Republic of Belarus,
Head of the Aerospace Activities
Department, Deputy Head
of the Space Research Agency
of the National Academy of Sciences
of Belarus



an important element of the concept of sustainable development and will be featured by tangible results at the international level.

I wish participants, organizers and guests of the conference fruitful communication, exchange of experience and further professional success!



I am confident that today's event will strengthen ties between scientists and practitioners, while survey of space and the innovative projects presented here can be an important element of the concept of sustainable development and will be featured by tangible results at the international level.

Dear Anatoli,

Dear participants of the VI International Scientific and Technical Conference "Non-Rocket Near Space Industrialization: Problems, Ideas, Projects",

Many fantastic ideas expressed by writers in literature are working in our lives today. Perhaps the non-rocket system of near space exploration will materialize in the future as well.

The study of space is rooted in our land. In the treatise "Great Art of Artillery" published in 1650, Belarusian Kazimierz Siemienowicz for the first time proposed the technology of powder charge separation into compartments for artillery shells, which was later applied in the creation of staged rockets, and also described the possibility of using jet propulsion. All over the world our fellow countryman is recognized as one of the founders of rocket engineering.

Semyon Kosberg from the city of Slutsk was an associate of Sergey Korolev and the chief designer of the third stage liquid engine. It was this invention that made it possible to accelerate the Vostok spacecraft with the first cosmonaut on board to the second cosmic velocity and launch it into orbit.

Zygmunt Florenty Wróblewski, born in Grodno, was the world's first to master the physics and technology of gas

liquefaction and to obtain liquid oxygen and hydrogen which are the essential components of jet fuel.

Boris Kit, another outstanding scientist from near Kovelichy, developed the technology of using liquid hydrogen as a rocket fuel, which was applied in the American Apollo series of spacecraft, including Apollo 11 delivered American astronauts to the Moon in 1969, as well as in the Space Shuttle project spacecraft.

We are also proud of cosmonauts Pyotr Klimuk, Vladimir Kovalyonok and Oleg Novitsky, who have made three space flights each.

We highly appreciate many years of fruitful joint activities of Belarusian and Russian scientists and specialists in building and operating space equipment and implementing scientific and technical cosmic programs of the Union State. Since 1999, seven of them have been realized, two are underway and several are being finalized.

This made it possible to build the Belarusian space system of Earth remote sensing (ERS), to develop and put into orbit the Belarusian ERS spacecraft and the similar Russian Kanopus-V with a resolution of 2 m. Today, there are four Belarusian satellites in space orbit: Belarusian Cosmic Apparatus, two Belarusian State University nanosatellites and the Belintersat-1 communications satellite.

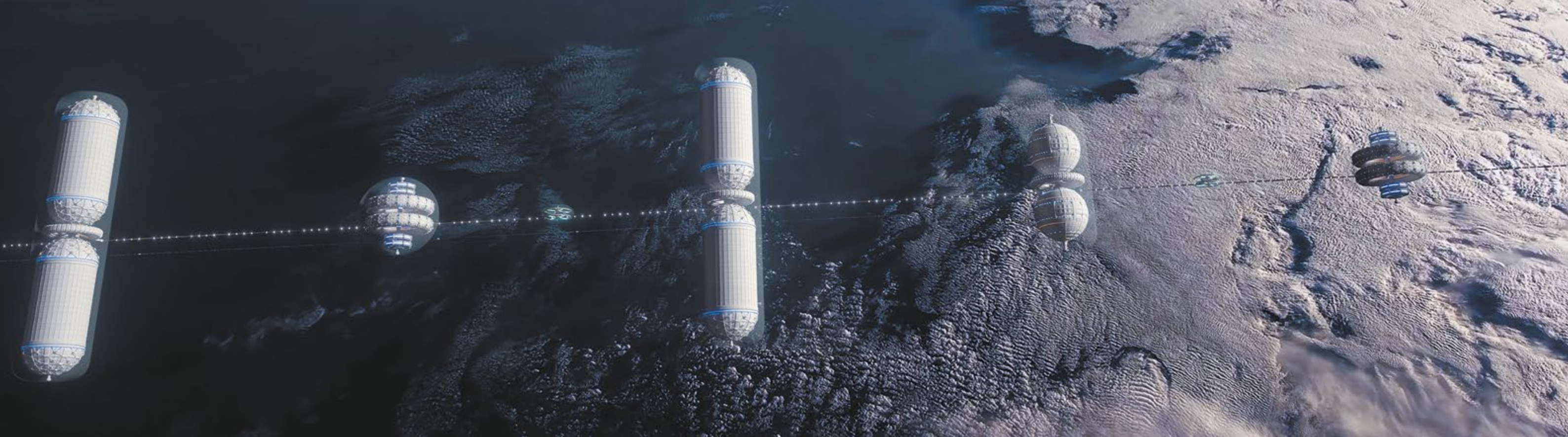

According to the Decree of the President of the Republic of Belarus, the National Academy of Sciences has been entrusted with the functions and tasks of organizing and coordinating work in the space industry. To fulfill these decisions, the Space Research Agency of the National Academy of Sciences of Belarus and the Aerospace Activities Department were established.

At the 68th Session of the UN General Assembly on November 1, 2013, our country was accepted as a member of the UN Committee on the Peaceful Uses of Outer Space. Belarus became a full member of the International Charter "Space and Major Disasters".

Our republic is actively involved in global cosmic activities. National scientists take part in congresses organized by the UN Office for Outer Space Affairs, the European Space Agency, space agencies of Russia, the USA, Japan, China and other countries.

In 1985, the Association of Space Explorers, an international nonpolitical and nonprofit organization, was established to unite efforts to share experience in piloted astronautics. It holds annual congresses in different countries around the globe. In 2018, the 31st congress was held in Minsk, which brought together 81 astronauts from 18 countries. During the event, in honor of our compatriots, a memorial sign

"To Belarusians – Heroes of Space" (the work of Belarusian sculptor Ivan Misko) was opened in the capital on Kosmonavtov Street and the Alley of Cosmonauts was laid in the Central Botanical Garden of the National Academy of Sciences of Belarus – the largest alley in the world planted by astronauts at one time.

I would like to note that the space industry in the Republic of Belarus is successfully developing and has excellent prospects. Today only ERS technologies are used in our country by many enterprises and organizations of 11 ministries and departments. For wider application, a multilevel ERS system has been created, including, apart from the cosmic segment, aviation, uncrewed and ground infrastructure, and also the Belkosmos production corporation is in operation.

A new joint Russian-Belarusian ERS spacecraft with a resolution of 0.35 m is currently being developed, which will significantly expand the possibilities of using cosmic information and technologies for its application.

As part of the Union State, the Complex-SG program is currently being implemented, which envisages the creation of a constellation of three satellites: one small satellite, weighing about 250 kg, and two nanosatellites, one of which will be manufactured by the National Academy of Sciences of Belarus. This constellation is intended to test

new space technologies. It is also important to note that in 2024 it is planned to send a Belarusian female cosmonaut-researcher to the ISS.

Eight international congresses were held in the National Academy of Sciences of Belarus, and the sixth international conference was organized in Maryina Gorka. In 2023, together with Denis Isaev, Director of Astroengineering Technologies LLC, I took part in the conference "Prospects and Possibilities of Private Cosmonautics Development in Russia", which implies more active participation of the private sector in space exploration.

The event being held today features exciting reports on the development of space technologies. It is quite likely that Anatoli Unitsky's idea of non-rocket near space industrialization will be materialized by our descendants and the name of the Belarusian engineer will be remembered as we now remember the founders of space engineering and technologies.

I wish all participants of the forum success in achieving their goals and joining efforts in the exploration of space for the benefit of the people of our planet and for the sake of global peace.



It is quite likely that Anatoli Unitsky's idea of non-rocket near space industrialization will be materialized by our descendants and the name of the Belarusian engineer will be remembered as we now remember the founders of space engineering and technologies.

Welcome Speech by Michael Orloff,

Doctor of Engineering Sciences,
Professor, Founder,
General Director
and Scientific Supervisor
of the Modern TRIZ Academy
(Berlin, Germany)



Welcome Speech by Arseny Mitko,

Corresponding Member
of the Russian Academy
of Natural Sciences,
Ph.D. in Engineering Sciences,
Associate Professor,
President of the Arctic
Public Academy of Sciences



Dear colleagues, participants of the VI International Scientific and Technical Conference "Non-Rocket Near Space Industrialization: Problems, Ideas, Projects",

Dear Anatoli,

Please accept my best wishes for the success of a great cause to which you have devoted a significant part of your activity and a whole life.

Phenomenal and pioneer ideas regarding alternative principles and technologies of near space exploration offered by Anatoli Unitsky are worth to be actively developed for the benefit of our and future civilization.

What looks like a dream today can and must become a reality tomorrow.

I wish success to everyone and pure joy of creating!



Phenomenal and pioneer ideas regarding alternative principles and technologies of near space exploration offered by Anatoli Unitsky are worth to be actively developed for the benefit of our and future civilization.

Dear organizing committee, participants and guests, Congratulations on the opening of the VI International Scientific and Technical Conference "Non-Rocket Near Space Industrialization: Problems, Ideas, Projects". I believe that it is a significant event in the field of space exploration.

The scientific forum covers many prominent issues of near space industrialization at the current stage. Today there is high correlation between Earth and space. Therefore, now it is important to take a look at the Arctic, Russian polar region and test there the results of research (developments) related to the issue of extreme conditions, including:

- low oxygen content;
- social isolation;
- sensory deprivation and insufficient brain stimulation;
- lack of natural light during the polar night;
- cold;
- unbalanced diet;
- limited resources and their extraction by alternative methods.

We cannot live using only old practices, it is needed to create new opportunities, generate new scientific ideas and technologies, search for new ways. All of this is finally

embodied in the technical solutions by Unitsky String Technologies Inc.

To my mind, the main goal of this conference is exchange of advanced experience and accumulated unique knowledge in the sphere of near space industrialization. I am confident that the results obtained in the course of your research will benefit all humankind and the recommendations offered will be applied in practice.

I wish participants and organizers of the conference fruitful work, constructive dialogue and effective interaction.

Welcome Speech by Marina Minina,

Ph.D. in Engineering Sciences,
Associate Professor
of the Russian Academy
of National Economy
and Public Administration
under the President
of the Russian Federation,
Chairperson of the Arctic Council
of the Eurasian Peoples' Assembly,
Executive Director
of the "Arctic 2024" Summit



Welcome Speech by Andrey Fefelov,

Journalist, Publicist,
Editor-in-Chief
of the Den-TV Channel,
Deputy Editor-in-Chief
of the Zavtra Newspaper



Dear Organizing Committee and participants of the VI International Scientific and Technical Conference "Non-Rocket Near Space Industrialization: Problems, Ideas, Projects",

We have been witnessing the increasing number of abnormal climatic phenomena on our planet, such as floods, droughts, earthquakes, frosts. The snow suddenly falls in the Sahara, Europe is flooded with torrential rains, while the summer of 2023 was the hottest in the history of hydrometeorological observations on Earth. The science cannot yet explain whether human activity influences the climate or nature decides by itself there will be a new ice age or global warming.

That's why more and more scientists, practitioners, desperate dreamers, fantasists look at space, and this conference which we participate in is aimed to answer many complex questions regarding industrialization of near space.

Space exploration can be considered as continuation of centuries-old human activity on habitat development, settlement and distribution of productive forces.

In terms of ways to solve transport and infrastructure problems areas of the Far North may be identified with space. Even now it is a huge task to find balance and harmony between unpopulated northern regions and innovative technological solutions for their development.

The organizer of this annual conference, Astroengineering Technologies LLC, and a team of scientists and designers, technologists and engineers bring humanity closer to the dream of space exploration. Herewith, scientific achievements of Unitsky Group of Companies in designing linear cities, biotechnology and life support systems which can be applied in the Arctic extreme conditions are equally important.

I wish all conference participants fruitful work, heated discussions and new discoveries!

Dear conference participants,

In our time, futurological discourse is extremely valuable, because the image of the future alternative to the Schwab's one and visions for our desirable tomorrow have not been formulated. It is worth recognizing that the official discourse in both Russia and Belarus as well as large part of society's consciousness are focused on the past, on tradition, on conservative values. All this is great and necessary but completely not sufficient condition for building our future.

So, what is needed?

First of all, the ideology of the future and answers to the main challenges of the 21st century are required. During the collapse of globalism, the disintegration of the world into macroregions, close attention should be paid to our 1/6 of the land. The rebuilding of Greater Russia is a necessary process and, under these conditions, we can say, inevitable one. The broken "cup of Russian space" must be reconstructed, probably in some new political forms but within the same – historical – boundaries. Greater Russia is a re-ort in which a supernova society should mature. Without this great unity of peoples and bridgeheads, we will not be able to withstand the pressure of opponents, partners and competitors.

The second aspect that should be considered is the human problem. Modern technogenic digital civilization encroaches on the human's limits. Radical environmentalism, genetic engineering, the theory and practice of "transhumanism" strive to "roll up" a human in asphalt of "progress". The attempt on a person must be repulsed. The future needs human as a species, as a type, as the image and likeness of God.

For this purpose, it is necessary to define a person, to define boundaries that cannot be violated even in the name of progressive goals.

The third component is questionable to me. Many people will say that this is justice. However, in the current conditions, development is more important than justice. The distribution system, the national rent from the exploitation of natural resources, unfortunately, will not lead to social growth. It is much more important to create optimal models of education, management and personnel selection. We do not need a society of universal welfare but a society of universal establishment. Tension and development will turn us into a rocket flying vertically upward. Only such a movement will allow us to reach a new civilizational stage.

For this, we need to define not only what a person is but also what is development, its purpose and meaning.

UDC 62+001.18

INGENIUM. The World as an Engineering Project

A. Unitsky
Dr. of Philosophy
in Information Technologies
(Transport)

Astroengineering Technologies LLC,
Minsk, Belarus

Unitsky String Technologies Inc.,
Minsk, Belarus

”

The modern world was created by engineers. The technologies they develop determine not only everyday life but also the way of science and culture development as well as the Earth's appearance and the state of nature. However, the society management is given into the hands of politicians and entrepreneurs, while engineers only serve their interests dictated by power and profit. Environmental problems of the 21st century, wars, economic inequality and social injustice are the result of almost limitless possibilities achieved by engineering while maintaining its moral neutrality established in previous eras. Based on extensive historical and philosophical material along with data from exact sciences, statistics and sociological research, the author assesses the role of engineers in the formation of our technocratic civilization in a new way. He carries out the analysis of the sociopolitical system of the 21st century as well as the logic of its formation and the image of a rational future built on its basis from an engineering point of view. He also studies value aspects of engineering activity along with fundamentals of ideological and industrial approaches corresponding to the level of technology development achieved at the time of writing this text as well as current global environmental, demographic and industrial challenges.

Keywords:

engineering, eschatology, global energy consumption, overpopulation problem, space exploration, technosphere.



1. Formation of the Technosphere

1.1. Engineers Created Our World

Our world was created by engineers. The modern civilizational world as we know it became possible only through engineering. It was the work of thousands of generations of nameless engineers over millennia that created the objects, systems and technologies surrounding us every day. From stone axe, fire, wheels, nail and bolt to car, airplane, iPhone, power plant and spaceship, all of these are products of the engineer intellectual work. Only engineering and technological advances have made it possible for humanity to take a dominant position among the millions of living beings that inhabit our planet. If you turn off electricity, heating and sewage, stop factories and plants – the world will quickly plunge into a primitive state. It is no exaggeration to say that without engineering devices there would be no politics, no art, no religion, no state, no society and no other form of social and spiritual life.

Human civilization differs from other terrestrial civilizations, for example, from such a purely biological civilization as dolphins. They occupied a biological niche in the biosphere, which had remained unchanged for millions of years. They do not have technocracy, science, art and the problems associated therewith. Although humans and dolphins are somewhat similar, as those marine mammals differ from other animals by their high intellect. Besides, they have their language, even more complex than that of humans, so it is possible that their intelligence may be higher as well.

Our civilization, unlike other terrestrial societies, is a technocratic (technogenic) social system, the genesis of which is based on the development of science, engineering, technology and production as well as the extremely urbanized environment formed around these systems – inanimate (industrial) technosphere, which occupies the same natural niche on our planet as the biosphere – not only the surface of the planet but also many kilometers of sea and land depths and the lower part of the atmosphere.



This alien to earthly life technosphere exists and develops according to approximately the same antagonistic principles as, for example, a cancer cell in a living organism, which is booming due to the suppression and destruction of healthy cells. Only two scenarios are possible: either the body's immune system kills cancer or cancer defeats the body and then dies itself.

The engineering technologies (not the natural biological ones) have been formed according to the laws of macroworld (not of the micro- or digital world, i.e., physics and not of philosophy and society). These technologies have created (in a very short time by historical standards) the modern human technogenic civilization.

When our ancestors were hunters and gatherers, they had only the most primitive tools at their disposal. Because of limited resources, with their own effort one person could only feed themselves. If things worked out well, there was something left for the kids. Nothing more. This is why slavery was impossible for a long time. Slaves must work hard to provide necessary things for at least two – themselves and their master. There was much to learn, much to discover, to tame animals and to invent plow.

Marxist teaching about the base and superstructure grasp an important side of civilization development. Any significant transformation of society is linked to changes in the so-called productive forces and, above all, in the tools of labor along with technologies that meet people's needs. I do not share the belief in the primacy of the base over the superstructure. In my opinion, this is too simplistic. Its falsity is disputed by a lot of facts. For example, the October Revolution, which supposedly led to the establishment of a new formation, was much more influenced by the processes that took place in the minds of people as well as in the culture and politics of that time. Russia remained a predominantly agrarian country. The proletariat was a tiny minority. Nevertheless, their dictatorship was proclaimed. Also, there's a well-received theory of postindustrial society that has the service sector, not industry, in its focus. The transition to such a state is also difficult to relate to the transformations taking place in the base. But it remains true that every significant change is provided by some technology created by engineers. All spheres of life and the nature of people's views are mediated by the same thing.

For a 21st century human it turns out to be normal to comprehend themselves and even to build corresponding anthropological theories in the terminology of cybernetics. People, for example, talk about their memory by counting it in gigabytes and think about health using words borrowed from video games such as "health point". They describe

mental states, resorting to "crashing", "lagging", "bugging" and other terms. The world and God are interpreted by analogy with computer programs and programmer activities. Sometimes it gets funny. However, more often there are tragic consequences, as in the case of Adam Lanza, who shot 26 people, feeling like a computer game character in pursuit to "score as many points as possible". At the same time, there is nothing unique in the description. We have always considered the reality in one way or another in relation to the achieved level of technology. Engineering solutions often proved to be the key to thinking.

1.1.1. How Does Religion Owe Engineers?

In the 17th-18th centuries with the flourishing of mechanics, people were describing themselves and everything around them as mechanisms. Julien Lamettrie wrote a book titled "Human a Machine". The Deists painted the Universe as a sort of a giant clock, set by God. Even earlier, with the appearance of the first religious teachings on how God had created human and the world, this reasoning came through the metaphor of pottery. The idea that human is made of clay came only after the invention and distribution of the potter's wheel. The already mentioned plow and general development of agriculture gave rise to many religions that perceive the origin of everything uniting the masculinity of the sky and the feminine principle of the earth. The land is plowed over with a plow serving as a phallic symbol in Sigmund Freud's terminology, and after that it produces a crop. In almost all agrarian cultures, land is described as a female, a mother-breadwinner, etc. The beliefs of peoples who have not drifted away from the life of hunters and gatherers are usually associated with the worship of forest spirits, sacred animals and so on. Unaware of the technology of growing vegetables and fruits, they often do not even understand the causes and mechanisms of impregnation, do not link pregnancy with making love.

In the history of religion, one can find many examples referring to the use of technical innovations in religious practices. Ritual dancing with a tambourine around a campfire or lighting a pipe of peace – all of it belongs to technological innovations that dolphins lack, as well as most likely they do not have religion. One can also cite as an example the use of techniques for the replication of sacred texts. Religious books were created thanks to technical innovations in writing, such as brushes, mastic, parchment, paper and printing. Construction techniques and technologies, such as stone cutting and wood processing along with manufacture of bricks and binding materials, played

a major role in creating architecture for religious sites and shrines. Churches, temples and mosques are defined by architectural styles that have emerged due to technical innovations in construction. Glass founding and stone machining as well as the possibilities of melting and forging metals allowed religious leaders and architects to create impressive and complex architectural objects.

There are even more examples of how technology impacts thinking, but in this section it is enough to assert that the religious worldview correlates with the level of technical development of the epoch. Believers and religious figures, just like nonbelievers, wear clothes and shoes, use cars, airplanes, computers, iPhones and the internet. In addition, it is only necessary to point out one more circumstance – the weakening of the religion role in society is associated with the strengthening of the technological equipment of humankind. At the same time, the place of religious experience does not remain empty. For answers that were previously sought in church, the 21st century people increasingly turn to search engines like Google. Let us leave this here as an invitation to reflection and go further, analyzing how the development of technology influenced the formation of philosophy and science. It may seem that the direct connection is obvious. But this is not quite true.

Engineering gave more for the development of civilization than science did, although there is a directly opposite point of view. In science, you don't need to invent something, in science you need to discover what already exists in nature, regardless of our consciousness and understanding, for example, the discovery of volcanism on the Moon or radio waves. Radio emission existed before Heinrich Hertz, who discovered electromagnetic waves, but everyone remembers in this connection not him but Alexander Popov and Guglielmo Marconi, who invented (but did not discover) a radio transmitter and radio receiver and made it out of coils, relays, antennas and other parts not invented by them. Therefore, everything that is made by human hands and surrounds us was created not by scientists but by inventors, i.e., engineers, since without engineering knowledge and technical details, elements, assemblies and equipment invented by previous generations of creative people it would have been impossible to do this. Science cannot exist without engineering. It is infeasible to discover volcanism on the Moon without a telescope, just as it was infeasible to discover the Higgs boson without the Large Hadron Collider – a miracle of modern engineering. Science is not the cause, it is the consequence of engineering progress.

1.1.2. Prerequisites for the Philosophy and Science Formation

I want to draw attention to the fact important for my research. Philosophy and science existed long before the appearance of many advanced engineering technologies. Although the basic technologies, such as fire, tools, weapons, clothing, housing construction and other engineering solutions, were already available. As there was already a language – those who learned to pronounce new sounds as well as give names to objects and phenomena around them and then transfer this knowledge with the help of sounds to other people, were information technologists, i.e., engineers.

Ancient civilizations, that knew about the movement of stars and planets probably even more than we do, laid the foundations of astronomy and mathematics. Antiquity is already the pinnacle of rhetoric, logic, ethics, aesthetics and natural philosophy. The Middle Ages reached the limits in building various models of metaphysics and theological doctrines. But almost all this time, epoch after epoch, humankind used devices that had little change to them and were quite simple on the 21st century scale, such as a wheel, gear wheel, lever, inclined plane, pulley and screw.

For Antiquity, technology was considered something unworthy. A free human had to be immersed in the world of ideas as a rational being before everything else. Dealing with the world of things was the domain of a slave who is a thing by definition. The engineers, of course, were in good standing. They have achieved great success in the construction of buildings and ships. But on the social ladder, they, along with artists and poets, were located much lower than politicians, philosophers and warriors. The Middle Ages, following these guidelines, generally put everything material and corporeal below the spiritual. In some cases, one can speak of contempt for the material world as an imperfect likeness of what can be comprehended only by prayer and reason.

Neither in Antiquity nor in the Middle Ages there was anything that could be a prerequisite for the formation of natural science. Firstly, it was unacceptable to interfere with the world created by God and to perform certain experiments, considered violence in itself, on it. This could be regarded as an encroachment on the divine world order, as an attempt to change the natural course of things in favor of one's own will, which was equated to witchcraft and could've ended with the Inquisition's bonfire. Secondly, it was believed that human, as the image and likeness of God, contains all the knowledge that can only be available to them.

Only the mind, dealing with ideas that precede things, is able to comprehend the essence of these things.

To illustrate what has been said, I will recall an anecdote about two monks. It seems to have been composed in the Middle Ages and describes well the spirit of knowledge of that time. The monks were walking around the garden and saw a lot of holes dug by moles. They began to discuss whether a mole has eyes. The first argument was that an animal spending almost all its time underground does not need eyes. Divine providence does not create anything unnecessary, which means that the mole has no eyes respectively. The second monk objected that since the mole sometimes comes to the surface, it needs eyes and, therefore, they are present. The argument continued in the same vein. Then the gardener approached them and offered to dig up a mole to check which of the hypotheses is correct. In response, he heard: "Go away, ignoramus, you don't understand anything about learned conversations."

For a long time, cognition was mainly speculative in nature. What has changed? And why did engineers start playing more and more prominent roles? Here again we will have to make a reference to Marxism, which is especially important in the following description.

The transition from the feudal formation to capitalism, in which engineering developments began to play a decisive role and in which experimental science was formed, is described through the process of initial capital accumulation. In general terms, the logic is as follows:

1) people hungry for profit by their own means or with someone's help come up with engineering solutions that allow them to achieve selfish goals more effectively. First of all, they need transport to trade as well as weapons to protect their wealth and take away the wealth of others;

2) engineers gradually create more and more advanced vehicles and weapons. Trade becomes an increasingly reliable and safe way of getting rich. Ships sail farther and farther and sink less and less. Attacks on caravans require more and more technical equipment and are available to fewer and fewer people;

3) wealth, the size of which turns out to be much larger than the fortunes of some kings, is concentrated in the hands of the most successful merchants who inhabit territories on the shores of the Mediterranean Sea, which are the most favorable for their activities. And although the merchants themselves often do not even belong to the nobility, they begin to experience royal ambitions. In particular, this is expressed in the desire to perpetuate oneself in some way;

4) newly rich class promote artists, builders and inventors who create portraits and palaces for them as well as various devices intended for fun, such as musical instruments and other mechanisms. The people serving the first capitalists are forced to look for new and new ways in order for each work to be unique and thereby amuse the customer's ego. At the same time, work is carried out within the framework of material world, not only the spiritual one. Materials are being searched for while properties of substances as well as original techniques in construction, painting, sculpture and mechanics are being discovered. The purpose of everything is purely practical. It is neither to serve the state, as it was in Antiquity, nor to serve the king or the church, as it was in the Middle Ages. Now the goal is to please an ordinary person and, in fact, to make their life as comfortable and safe as possible. At the same time, the achievements of engineers are analyzed and recorded in scientific books.

This is how the Renaissance and the Modern Era began, forming the experimental natural science being the basic of a contemporary one. We can see the decisive contribution of engineers with their role being more significant than before due to an increase in the number of needs, as they remain a class that serves these needs. Despite the fact that due to the engineers' efforts the resources necessary for both the formation and satisfaction of these needs have been released and concentrated, engineering began to be at the service of money more and more, while continuing to be at the service of power started back in the days when the invention of the axe or spear gave one tribe an advantage over another and helped to prevail. Around the same years politics has emerged and it was also thanks to engineers.

1.1.3. Emergence of Politics

Politics, like trade, only to a much greater extent, is connected with the improvement of weapons. The primitive bow and fire followed by gunpowder and projectile – all these inventions have changed and largely predetermined the nature of politics. If it is true that politics is a struggle for power, and war is an extreme form of struggle for power, then tribal warfare in the primitive communal system is the limit of possible political claims of that time. Why were there no great armies and great campaigns? Because the great army needs a large supply of fodder. This means that carts are needed, and they are much more complex devices than stones and sticks. In addition, the bronze or iron sword allows you to kill with one swing, without plunging into a scuffle with improvised objects. The army becomes

capable of crushing with lightning speed and moving on, without leaving the enemy's unfinished soldiers behind.

The fleet created by engineers opens up new scales of politics. Now it can spread beyond continents. Empires that unite peoples are being created. Firearms, as they spread, allow politicians to be less afraid of adversity such as peasant uprisings. You just need to prohibit commoners from having guns – and any rebellion becomes relatively easy to suppress. Although in previous centuries, several people armed with pitchforks posed a serious threat even to an armored knight. The more technologically advanced weapons became, the more power it was possible to concentrate in one hand. This direct correlation between the extent of power and the degree of killing devices perfection was probably the root cause for the weapon development always being at the peak of technological progress.

The bow for hunting and war was most likely invented earlier than stringed musical instruments. The axe was before the hammer. Gunpowder, however, is an exception, and it was initially used for fireworks while bombs, cannons and muskets were invented much later. In all other respects, there were almost no exceptions in the rule of military engineering being prioritized over the civil one, since there were politicians who concentrated wealth in their hands and could afford to pay engineers more than anyone else. The warhead launch vehicle was developed much earlier than the rocket used for conquering space. The atomic bomb preceded atomic energy. The first satellite, the first computer, the first robot – all this was created by order of the military always serving politicians. And engineers, whose efforts have built the foundations of the most powerful states, also turn out to be service personnel. At the same time, they often become accomplices of the most terrible crimes directed not only against people but nature as well. However, good deeds also happen thanks to the intellect and the hands of engineers. By creating prerequisites and tools for the development of sciences, making possible and determining the content of art, they give humanity numerous reasons to hope for the best.

1.1.4. Origin and Development of Art

The art of music is impossible without musical instruments created by engineers, while painting is not able to do without paints and brushes – they are quite engineering developments as well. As for the literature, at some point in its development it became necessary to create parchment, papyrus, paper and later a printing press. In turn, a theater is not only a building but also various mechanisms, lighting

and much more. Already in Antiquity, Heron of Alexandria prepared an essay called "Automatic Theater", in which he described complex structures that, due to the use of gravity, allowed changing the scenery automatically. Everything happened according to a preplanned scenario, in strict sequence, considering time intervals. The machine worked like a clock or even like a program implemented not on punched cards but on rolls with spikes and ropes wound on them. This is how the engineer solved the problem associated with the creation of the show. Finally, there's cinema that is a complex synthesis of various high-tech engineering solutions. However, more importantly, as in the case of religion, art is defined by engineering not only technically but also in terms of content and existentialism.

You can refer to the etymology of the word "art" itself. It has a common root with "artificial". Something that is not natural. It is human-made. It is already implied here that an artist needs tools. The primitive authors, who painted hunting scenes on the walls of the cave, had a fire in this cave to provide light. They invented or borrowed a way of drawing lines and strokes. They found the necessary materials. In the end, they survived, reached adulthood and were able to feed themselves – also thanks to engineering devices. Moreover, and more importantly, their chosen theme reflected the goal and the pinnacle of engineering excellence of those times. Spears, stones, traps, rituals using musical instruments – all this is a world created by engineers and made possible thanks to them. They formed the perception and the plot for the artist to illustrate. Similarly, abstract art of the 19th–20th centuries is associated with the appearance of a train and a car, which set a different speed of movement and then the nature of perception of reality, blurring the faces and outlines of objects, breaking them into fragments.

The technogenic world is not just the world of science, technology and engineering, which is not a bad thing in itself, but also the world of the material: material production and consumption, material relations and contacts. The entire strength of modern civilization – agriculture, industry, transport, energy, electronics, computers, smartphones, the internet, cities, roads, etc. – is created by engineers.

Before engineers understand how to save the planet, the biosphere and our technogenic civilization, it is worth looking back and tracing the entire history of the Earth's civilization from an engineering point of view. It is also useful to look at the relationships between two global ecosystems: the biosphere, shaped over billions of years of evolution by Live Nature, and the technosphere being created by *Homo sapiens*, or more precisely, *Homo technocraticus* [1].



1.2. Engineering Chronology

1.2.1. Engineering Epoch Technosphere 11

(approximately 2 mln years B.C. – 5,000 years B.C.)

Engineering thought originated at the primitive stages of social evolution, long before the appearance of civilizations. This inevitable necessity with concrete pragmatic results in the form of the first primitive inventions marked the beginning of an endless technogenic path. At the heart of human activity is the primary experience of interaction with the outside world. Accumulating within the boundaries of one human life or entire generations, this experience inevitably turns into a new quality. Skills are being developed, the notion of previously unseen patterns emerges, rules are being drawn up, and new opportunities are opening up as well. At the same time, new needs arise and various sociocultural models are being formed.

At a higher stage of cognitive ability, with the accumulation of practical and abstract experience, the world gradually becomes more complicated. The earliest religious

and ceremonial practices in the worship of elements or the veneration of ancestors were already distinguished by the qualities of a structured activity organized according to certain rules. Thinking strives to realize its creative potential thus resulting in the emerging of arts. Moreover, the experience of interacting with physical matter (water, air or stone) in any practical activity is so deep that its roots go back to unconscious times. Such an experience was accumulating in us even in the epochs preceding the state of savagery, at the beginning of the path of that beings who one day realized themselves as humans.

A person began to divide practical activity into the construction and arrangement of a dwelling, the invention of hunting tools and cultivation of the land, the creation of places of worship for the service of cults – this is how crafts were formed. At the stage of the tribal society decay and satisfaction of primary needs, they were already an integral part of life. The advantages that crafts gave along with new knowledge and arts were steadily changing the world.

In history, we observed an ever-increasing pace of development, mutual influence and interweaving of various kinds of human activity and ideas. There came a time when engineering became something of a luxury and intellectual game for elites. Archimedes in the 3rd century B.C. came close to the origins of mathematical analysis, laid the foundations of hydrostatics and designed such effective mechanisms that thereby delayed the capture of Syracuse by the Romans for several years. The image of an ancient Greek philosopher-mechanic, bent over drawings despite the risk to his life, was inspiring subsequent generations of engineers and researchers. Did Archimedes need a royal crown? If so, then only in order to come up with a universal method for assessing the purity of the gold alloy from which it was made.

The vast world of natural science with a variety of thinking and theoretical approaches in its study was attractive in itself so much that often the conclusions obtained could not be consistent with reality. And as they said in such cases, resting on another paradox, dualism or denial in general: "So much the worse for reality!" In fact, the work continued, and science found physical confirmation of what previously existed only as a result of private speculations.

The technological vector of human development, which in the 21st century turned into an industrial one, was chosen about 2 mln years ago by our distant ancestor – primitive human. It started when not yet quite a human but no longer a monkey invented the first engineering technologies – lit a fire, began to fry meat on it, processed animal skins and made the first primitive tools [2]. Furthermore, people have domesticated the wolf, which allowed them to improve efficiency of the hunts and won in the interspecies battle. Later on, our ancestors, the Cro-Magnons, due to their inherent anatomical features (one might say, a physiological "defect") that were insignificant at first glance, namely the structure and location of the vocal cords, made a fundamental evolutionary leap by inventing speech. It enabled the possibility to accumulate and transmit oral knowledge from one person to the others. This became the most important social invention without which further development of engineering technologies would not have become possible.

It can be identified as the first technological development level for different tribes (clans), when the concept of "humanity" had not existed as of yet. This period lasted for about 2 mln years. That is, until the ancient engineers invented the wheel, saddled the horse and hitched it up to the first wagon (about 5000 B.C.). The communication of ancient human, like any other animal, in the first epoch was

limited only by the natural parameters: muscular strength (running and walking as a material and energy component), vision, voice and hearing (an informational component).

It was the first (perhaps even zero, at the level of the ground) floor of the endless technological staircase of the infinitely high building named engineering knowledge, having its floors that are technological (more precisely, engineering) epochs. However, even then scattered tribal civilizations had experienced their first local (house-based) ecological crises. People burned bonfires and processed skins in the caves, i.e., their homes, thus dying of lung cancer at the age of 20 from the unbearable smog and carcinogens contained in technological wastes. Although the capacity of "technological equipment" – the fire – was low, about 10 kW, and the technological fuel – firewood – was quite safe and harmless.

Nevertheless, they survived by taking their first technologies outside of their own homes, caves, to the surrounding environment. This technological solution required the creation of additional transport communications – footpaths. The volume of movement then was small, the distance – short: a person physically cannot carry a heavy load far. However, there was no special need for this, as primitive "production facilities" were located near the caves.

Tribes appeared as the first technogenic communities. Gradually, they had initiated formations of nations, which were united by the common interests formed around the ancient technologies. This fundamentally distinguishes us, people, for example, from the dolphin civilization mentioned above, which developed parallel to human but did not use any engineering solutions in their evolution.

The invention of the spear about 500,000 years ago [3] along with creation of the bows and arrows in the 12th millennium B.C. (the main type of weapon up to the 17th century) played a crucial role in the lives of our ancestors. With these weapons hunters got a possibility to kill animals and birds at a distance of up to 150 m. The bow and the arrows were the first complex composite hunting tool which has resulted from a whole epoch of human thinking as well as observation, centuries of experience, considerable mental abilities and knowledge of other ancient inventions, such as spears, spring traps, throwing sticks and traps.

Ancient people began to use hunting weapons in another capacity that was already social: people chose war as a way to release their aggressiveness in the battles for the territories, food sources, resources and partners. This is how one of the first professions appeared – it was a warrior capable of only one skill: to effectively kill others,

i.e., their own kind, with the help of special murderous weapons (chopping, stabbing, striking, etc.) invented by primitive engineers.

The life energy used by our ancestors in this epoch was solar energy, which was transmitted along the food chain from phytoplankton and green plants to animals and humans. The technological energy consumed by ancient people (firewood, for instance) was also solar energy.

The world population has reached 10 mln people by 5000 B.C.

The essence of *Homo sapiens*, when interacting with the surrounding world, became two-component in those days: the first component is its biological basis, numbering about 4 bln years of evolution of living matter on planet Earth, the second is technological (i.e., technogenic) feature manifested in the engineering activity of their intelligence. The root of all modern global problems is precisely in the second component of the intelligent person. Therefore, this problem will be further prioritized in this work.

1.2.2. Engineering Epoch Technosphere 1.2

(5,000 years B.C. – the last quarter of the 18th century)

The epoch Technosphere 1.2 had absorbed all the achievements of the bronze, iron and ancient eras of human history as well as the Middle Ages. During this period, a large number of discoveries were made followed by the breakthrough inventions and creation of innovative industry technologies such as:

- ore mining and the inception of nonferrous and ferrous metallurgy;
- blacksmithing and the first manufactories;
- harrow, plow and agriculture;
- wheel, bridle, yoke, saddle and other harnesses, cart and horse-drawn transport with a horse capable of developing a power of about 5 kW, which is an order of magnitude higher than human energy capabilities;
- first glasses, microscopes and telescopes;
- lever, nail, rivet, brick, gear, bolt, nut and on their basis – a variety of complex mechanisms, machines, structures and tools, including those for scientific research.

It was during the epoch Technosphere 1.2, when mathematics, philosophy, physics, the sciences of the microworld and stellar world as well as the sailing fleet appeared. The first geographical discoveries were made, thanks to which people have begun to realize themselves as humanity and civilization living in a resource-limited and confined planet Earth.

Humans continued to improve the existing weapons to create new ones to kill other humans, including clubs, maces, swords, throwing mechanisms, axes, sabres, daggers, rapiers, dirks and other blade weapons. Moreover, they invented gunpowder and firearms (small arms, artillery and grenade launchers) as well as the simplest powder rockets.

When the first states were formed, people created the army. The wars covered more and more areas and became more and more protracted and bloody – the duration of some civil strife exceeded 100 years [4]. The loss of human life from the technocratic vector of development began to grow in proportion to this development, even when a person had not yet coined a term such as "ecology".

The invention of painting, pictography, cuneiform writing, calendar, papyrus, manuscript, paper and printing made it possible to create, accumulate and transmit knowledge recorded on a physical medium without the need for direct human-to-human contact, which later played a key role in the inception and development of engineering technologies and the entire Earth's industry.

The development of the pack and wheeled transport on land as well as sailing vessels on rivers, seas and canals had led to the formation of the first road network. Looking back by 2,000 years ago, a developed network of communications was created in Europe and Asia, including transcontinental connections such as the Great Silk Road, the Royal Road between Egypt and Persia, communications between Egypt, Anatolia and Mesopotamia, the Amber Road between the Mediterranean Sea and Baltic States, the Lapis Lazuli and Jade Roads as well as the Tin Road between the Cornwall Peninsula in Great Britain and the Mediterranean.

The Sumerians, who invented the wheel, and then the Assyrians founded relatively long road network (it already happened about 3,000 years ago!), for the construction of which special engineering troops were formed within the army along with developing reference guides and road signs for its functioning. A network of horse-drawn roads began to form all over the world, and ancient cities immediately began to develop along them.

Hundreds of thousands of kilometers of carriage roads, mostly unpaved, were built on the planet. Transportation volume reached millions of tons per year with the travelling distance of hundreds or even thousands of kilometers. However, the average travel speed, including the rest stops, remained extremely low – less than the speed of a pedestrian, so the long journeys used to take days, weeks and even months.

The size of the spontaneously emerging cities was determined by a single infrastructure criterion – transport accessibility [5]. Back then people understood that the comfortable travelling distance should be limited by half an hour and should not depend on the weather conditions. In the ancient cities, the main transportation mode was the walks, thus the sizes of settlements were limited to a few kilometers, as can be observed in Ancient Rome, Athens or Jerusalem. During the Middle Ages, people were using horses and carriages, which increased the travelling speed and enabled them to cover 10 km in 30 min. Consequently, the size of cities reached similar figures, like it can be seen in Paris, Moscow or London.

The technological energy used in this period was only solar: from firewood and charcoal to horses (via feed) and sailboats (via wind).

By the end of the epoch, the world's population reached a figure close to 1 bln people.

1.2.3. Engineering Epoch Technosphere 1.3

(the last quarter of the 18th century – the beginning of the 20th century)

Main achievements of the epoch Technosphere 1.3:

- technological revolution in the textile industry (spinning machines);
- channels construction, the invention of the water engines and later the steam engines;
- appearance of the steam locomotives and the mass integration of railways;
- steamship construction;
- rapid development of the coal industry and ferrous metallurgy;
- invention of the telegraph;
- introduction of the first vehicles with steam or internal combustion engines, the first power plants and the first electric transport – trams and electric cars;
- creation of building composites and initiating the use of reinforced concrete and asphalt globally;
- discovery of radio waves and creation of radio;
- emergence of the automobile industry and the beginning of large-scale construction of paved roads;
- invention of the first tractor and the beginning of mechanization of the agricultural industry;
- first flight by plane and the creation of aviation;
- rapid development of popular sciences (mathematics, physics, mechanics, chemistry, philosophy, biology, etc.);

- explosive growth of industry and cities, the creation of industry and industrial countries, which is still an ongoing process.

Extraction of raw materials for construction, industry and transport had exceeded 1 bln tons per year, including stones, clay, sand, ore, coal, oil, etc.

The world's population reached 2 bln people.

The road network began to expand and there were qualitative changes in logistics infrastructure: the length of railways and gravel roads exceeded 10 mln km; the average speed of movement on the railway also increased and significantly exceeded the speed of pedestrians.

The capacity of thermal engines using fossil fuels began to grow and reached thousands of kilowatts for steam locomotives and tens of thousands for steamboats (for example, for Titanic it was 55,000 HP). The annual production of such machines, including cars, began to grow rapidly and exceeded the value of 1 mln units.

The industry and its servicing cities began to develop rapidly along the railways. Traffic volumes had drastically increased to more than 1 bln tons per year. The scale of construction, even using simple tools like mattock and shovel, was set at a high rate even for modern standards. For example, while Russia had been analyzing the need of the Trans-Siberian Railway going from Saint Petersburg through Moscow to Vladivostok (the Ministry of Transport offered an alternative project: to develop horse-drawn transport in the central part of Russia), in the United States, more than 20 similarly scaled railways were built over 15 years (from 1880 to 1895), with the combined length of 187,000 km. It created a sustainable foundation for the most powerful economy in the world [6].

More and more fertile lands were allocated for the transport infrastructure and industrial facilities. These lands were withdrawn from the biospheric processes. Subsequently, they were not used to grow green plants and did not produce oxygen, necessary for the living creatures. At the same time, the volume of industrial waste released into the biosphere had increased. This resulted in problems of regional ecology caused by industry and transport, from deforestation in adjacent territories to landfills and smog in industrial cities. Multinational corporations and rich people emerged, able to concentrate huge resources in their hands to make a profit from engineering technologies, including socio-economic and military-political ones. This had become the main criterion for the development of both individual enterprises and organizations as well as most countries.

The technological energy used in this era was only solar: from firewood, coal and oil (nonrenewable sources) to windmills and hydropower plants (renewable sources).

1.2.4. Engineering Epoch Technosphere 1.4

(the beginning of the 20th century – the third quarter of the 20th century)

The epoch Technosphere 1.4 was based on the following:

- production and rolling of steel alloys;
- development of heavy engineering industry;
- construction of giant hydro-, thermal- and nuclear power plants, transnational transmission of power;
- industrial development of inorganic chemistry products and the beginning of agricultural chemicalization;
- mass development of the automotive industry;
- development of aviation and aircraft industry.

Atomic and hydrogen bombs were invented as well as powerful multistage launch vehicles for them based on solid or liquid fuels. The rocket and space industry began to develop rapidly, both for military and peaceful purposes.

The following breakthrough technologies were implemented:

- the first artificial satellite of Earth, after which a person for the first time went to near space and, later, was able to visit the Moon;
- television and electronics.

Further development and improvement took place in the internal combustion engine and vehicles, aviation and shipbuilding industries, the formation of nonferrous metallurgy, production of synthetic materials and composites, organic chemistry products, oil production and refining.

Large-scale construction of highways had begun. As a result, the production of new vehicles with an internal combustion engine had increased dramatically: automobiles (cars and trucks with the production by tens of millions a year), ships (including hovercraft and hydrofoils), aircrafts, airfoil boats, surface-effect airborne ships as well as launch vehicles.

Access to the personal vehicles and highways had initiated creation of the American-like one-storey suburbs supported by the mortgage services, and it initiated the possibility to live dozens of kilometers away from the city, where the work is located. Simultaneously, the average speed increased to the values 5–7 times higher than the pedestrians' travel speed. The car has become the dominant mode of transport, because, unlike the railway, it is able to provide

transportation service "door-to-door" and can be purchased by any family or by a wealthy person.

The rapid development of all sectors of the industry – from agriculture and household chemicals to electronics and automobiles – had occurred with a single goal: to make a profit by satisfying the ever-increasing and specially cultivated consumption of technogenic products and services (including food) by a new kind of technocratic human – the person who consumes.

The fast growth of a new type of technogenic employers, like transnational corporations and oligarchs, working exclusively for profit, has led to the formation of new goals and objectives for them: limiting the growth of the Earth's civilization, including by eliminating "extra mouths". This is how the "golden billion" theory emerged. We'll speak about it later.

The rapid expansion of cities and megacities has increased the world's population to 5 bln people.

The development of technology and transport – rail, automobile and aviation – has created a powerful military industry in many countries. Two world wars were unleashed, the bloodiest in the history of humankind, as a result of which not only at the front but also in the rear about 200 mln people were killed. This became a visible manifestation of the anti-human actions of the finally formed so-called "deep power". Technological progress began to cause more and more tangible damage to the technogenic civilization that had given rise to it.

The power of machines and equipment using fuel, the combustion products of which were released into the environment (mainly into the atmosphere), reached the following values: tens of thousands of kilowatts for aircrafts, millions for power plants, over 100 mln kW for heavy launch vehicles.

The technological energy used in this era was mainly solar: from coal and oil to hydro, wind and solar power plants. However, a new source of energy has also appeared – nuclear fuel, i.e., stellar energy, since all heavy chemical elements (carbon, oxygen, etc.), including radioactive uranium, could only be formed during the explosion of supernova – this is the fate of the evolution of many luminaries in our Universe. That is why our planet and we, humans, are made up of "stardust".

1.2.5. Engineering Epoch Technosphere 1.5

(the third quarter of the 20th century – the first quarter of the 21st century)

I will list only achievements of the epoch Technosphere 1.5, such as:

- rapid development of the electronic industry;

- creation of microchips, microelectronic components and personal computers;
- emergence and large-scale spread of the internet and wireless communications;
- intensive development of fiber-optic communications and telecommunications;
- development of complex computer software;
- widespread use of robotics;
- large-scale production and processing of natural gas;
- comprehensive provision of informational services;
- emergence of 3D printing and artificial intelligence.

Next, it is proposed to understand the nature and possibilities of the engineering phenomenon and then to return to the journey through time and, based on it and today's realities, to try to predict the possible options for the Earth's human civilization for the future.

2. State of Affairs in the First Quarter of the 21st Century

2.1. Status of the World Created but Not Controlled by Engineers

So, almost everything that constitutes the basis of our civilization was created by engineers. However, this world is governed by others – those who prioritize personal enrichment; those who naively believe that in a situation when Earth is on the verge of destruction, money will save them. These people are sure that together with their families they will be able to take refuge on private islands, in underground bunkers, on submarines and Boeings with missile defense. But they are wrong. The planet's biosphere is one big room, devoid of even partitions; there is nowhere to hide.

The number of people living on Earth has exceeded 8 bln. Urbanization is accelerating, urban agglomerations are merging into megacities with a population of more than 10 mln inhabitants.

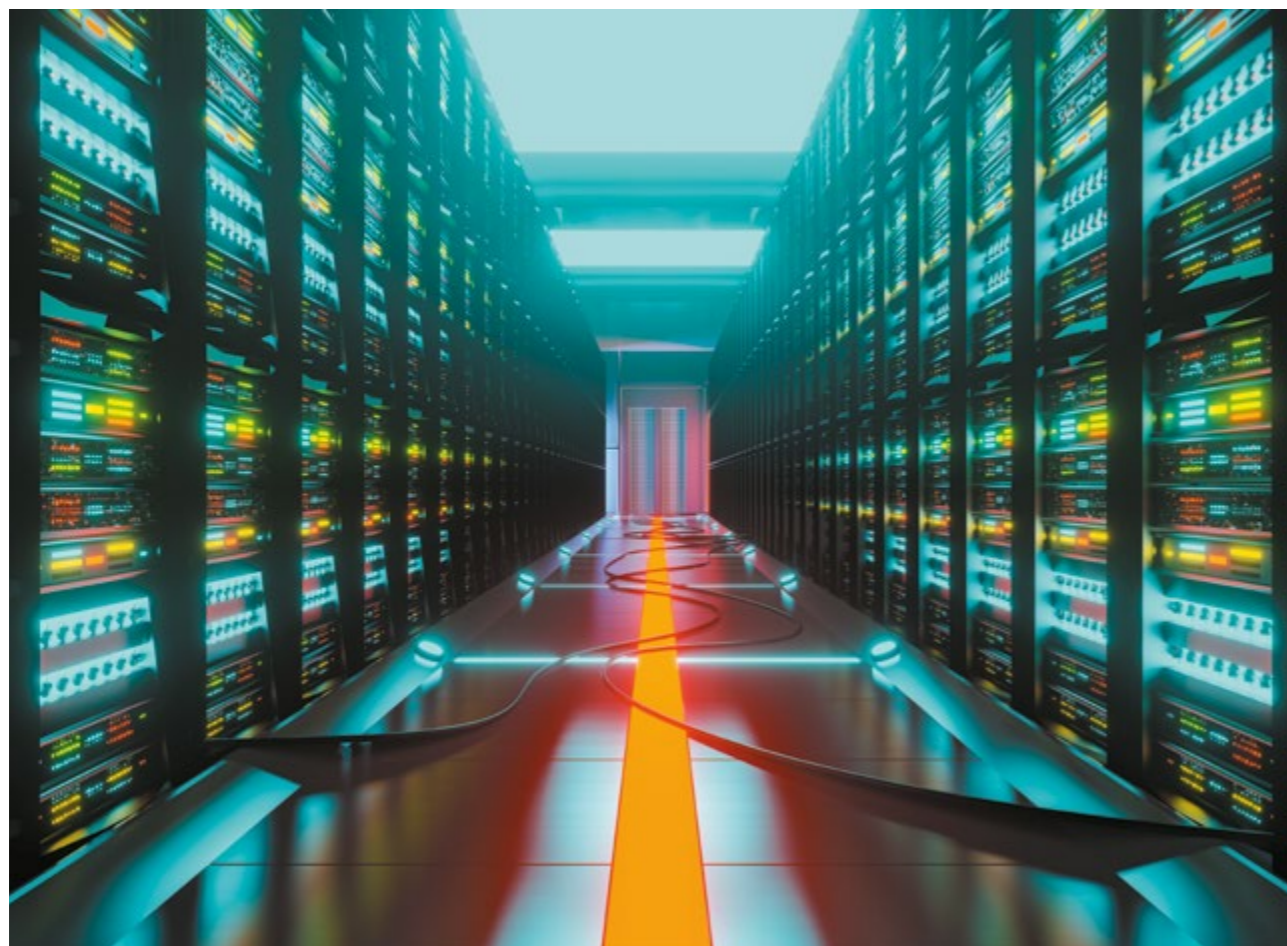

By the time of writing this text, there are 33 such megacities on the planet, including six cities with populations of more than 20 mln. The urban population began to prevail over the rural one and exceeded the 50 % mark in 2007. The present time is marked by the emergence of a new kind of techno-consumer, namely the "humans of asphalt and smartphone", who have atrophied their connection with the Live Nature that gave birth to them and raised them.

The construction of highways is progressing rapidly, the network of high-speed railroads is developing – the total length of all roads in the world, including the unpaved ones, is about 65 mln km [7] (of which more than 35 mln are paved). Planet's soils turned out to be "rolled up" in asphalt and "buried" under sleepers. Their total area exceeded the territory of Great Britain by five times. The soils adjacent to the roads, which occupy the territory 10 times greater, are degraded. They are polluted with products of fuel combustion, tire and asphalt wear, deicing salts containing more than 100 carcinogens, as well as waste associated with related industries – oil refineries, chemical and asphalt-concrete plants, graveyards of old cars and car tires and much more. Just their enumeration would take several pages of text.

Traffic jams of many hours and many kilometers appeared on the roads. As a consequence, the average speed of traffic in megacities dropped sharply (to the speed of a pedestrian) followed by air pollution and smog, consisting of a mixture of exhaust gases, tire and asphalt wear products as well as industrial gaseous and dusty waste. The quality of life in cities began to decline sharply, including due to the deterioration of transportation accessibility. Travel to and from work in many cities of the world started taking up the bulk of free time – up to 3–5 h daily. In some cities, it has become unsafe to go out without a mask (even before the coronavirus pandemic).

Engineering technologies have declared war on the technogenic civilization that uses them unwisely. And neither the technologies themselves nor the engineers who created them are to blame. Transportation in this invisible conflict is the most dangerous invention in the entire history of technological development. On the world's highways alone, approximately 1.5 mln people are currently killed each year (some of them die in hospitals from postaccident injuries and therefore are not included in conventional statistics), and more than 10 mln become injured, disabled and crippled. This is just the direct obvious damage that lies on the surface. The number of people dying every year in non-stop local wars on the planet as well as from technogenic disasters and terrorists' activities is several times fewer.

If the third world war happens, with its use of nuclear weapons, which can bring incalculable misfortunes and losses to humankind, transportation will also be to blame for the huge number of victims. Nuclear warheads will be delivered and dropped on peaceful cities by transportation means (missiles, planes, ships and submarines) invented by engineers.

The 21st century is distinguished by an increasing use of mineral fertilizers and toxic chemicals in agriculture, which leads to a catastrophic deterioration of the biogeocenosis of soils and food grown on them. In its biological essence, food is not so much a source of energy, but rather a building material for cells, organs and the body as a whole. Our cells live on average for about half a year, then die and are excreted from the body, and new ones appear in their place. At the same time, such a building material must contain more than 80 chemical elements in the form of a huge variety of organic compounds taken by plants from the living and fertile humus of soils. However, the degraded soil cannot give what it does not contain. That is why humankind began to increasingly use sort of biological "crutches", namely genetically modified products and dietary supplements (biologically active additives). In fact, in order to make an easy profit the food genocide of humankind has begun, as it allows for making huge amounts of money on it.

A powerful upsurge in pharmacology has taken place. You do not need healthy people to make a profit, since you can earn more on a chronically ill patient. Gene technologies began to develop rapidly. A human started to "improve" living organisms like an engineer. At the same time, due to their limited intelligence and knowledge, people are not only unable to understand the designs of what they are "improving" but also unable to foresee the distant results of such activities and the harm that may be caused to humankind in the future (as an example, the spread of coronavirus; and in the context of the above, it does not matter whether it is of natural or artificial origin).

The ideology of the planet's carrying capacity, which has already been allegedly exceeded, is being formed. Civilizational values are being revised and shifted to maximize the consumption of new and excessive material goods (new house, new car, new computer, new smartphone, new clothes, new shoes, etc.) as well as new services: transport (constant increase in the length of roads and the distance of travel by personal transport), energy (construction of an increasing number of thermal power plants, including the nuclear ones) and information (internet, mobile communications, television, mass digitalization).

Transition of consumers from material to virtual digital reality is being cultivated everywhere, as it is easier to earn higher profits there. In addition, the cult of emotional marketing is being created, which turned the vector of excessive consumption into the informational component: the market began to sell emotions rather than the goods themselves. This approach has sharply reduced the quality of goods. Why make a reliable and durable car or smartphone if in a year or two the consumer will buy a new one? Why reconstruct an old building if it is easier to demolish it and build a new one, and of lower quality? This has proportionally increased the resource intensity of all industries and raised the technogenic pressure on the biosphere.

The pervasive digitalization of society exacerbates the global problems of humanity, since any digitalization relies on the material component of the technosphere. In particular, the power of two power plants similar to Chernobyl Nuclear Power Plant is already being spent to support the global Bitcoin network [8].

More than 5,000 satellites have been launched into Earth's orbit to provide the internet and mobile communications. Elon Musk plans to put more than 40,000 satellites into orbit, which will require about 700 starts of the Falcon 9 heavy launch vehicle with 60 minisatellites on board [9]. But this will cause enormous damage to the Earth's biosphere and the planet's ozone layer.

The era is declaratively proclaimed as the century of saving resources (energy, raw materials, mineral, spatial, financial, labor, time, food, etc.) without a systematic understanding of the main thing: what, why, what for and how to save. Thus, over the century, the world population has grown by six times while the GDP – by 20 times, which has produced a multifold increase in the demand for some resources [10].

At the same time, humanity has entered an era of expensive resources – the era of low prices is a thing of the past. The expansion of the planet's middle class by 3 bln people within 20 years will increase the demand for new resources, and the search for other sources of minerals, energy, food and water will be complicated and too costly.

Shortages or price increases for one type of resources will spill over to others. An attempt to meet the progressive demand by means of proportional growth of production will require investments in the world economy of more than 10 trn USD annually [11]. This may become another springboard to the point of no return for the Earth's technogenic civilization.

Meanwhile, services, among which transport and logistics are the main ones, are not considered as the basic consumer resource. However, our civilization will not be able to exist

without them. Few people carry out optimization of these services, which are the most environmentally dangerous, costly and resource-intensive.

Roads and infrastructure, power plants and power transmission lines, communication satellites and the internet are created to provide humankind with qualitatively new communications, i.e., transportation, energy and information services. In engineering theory, these services can be much more efficient, accessible, economical, environmentally friendly and less costly (less resource-intensive) as well as be aimed at maximizing the savings of the most valuable and nonrenewable humans' resource that is time. In practice, they do not fulfill this role and everything happens vice versa.

The technological energy used in the 21st century is mainly solar (coal, oil, hydro, wind and solar power plants, etc.) and stellar (nuclear fuel). Engineers have a dream: to use the energy of singularity, i.e., the energy of thermonuclear fusion (its fuel, namely light chemical elements, including hydrogen, has formed about 14 bln years ago at the Big Bang [12]). However, there are no examples of solutions using this type of energy, although tens of billions of dollars have already been invested in the development of this technology since the 1950s.

This dream, for which humankind has spent 70 years (for example, the same amount of time the USSR existed) and tens of billions of dollars, is futile from the engineering point of view, since it has already been realized in a natural thermonuclear reactor – the Sun. Unlike Chernobyl and Fukushima, not a single accident has occurred in the Sun for 5 bln years of "operation"; there will be no accidents in the next 5 bln years either [13]. It is much easier to convert fusion energy obtained on the Sun into electricity than that produced in a tokamak (a human-made fusion reactor), therefore, people have been using solar power plants for a long time, but whether tokamaks will ever work is a big question.

Looking back at the entire engineering path traveled, one can see: the development of humankind was carried out in spurts. Generally speaking, there are only two significant shifts. The first one is the Neolithic Revolution (domestication of animals, fire extraction, invention of tools as well as the simplest mechanisms and devices – wheel, axle, wedge, lever, inclined plane, screw and block). In a short time, a colossal breakthrough of civilization was provided, and then we've been developing not intensively (qualitatively) but extensively (quantitatively) for a long time.

The second revolution, in general terms, is associated with the discovery of the scientific method and scientific

approach in engineering. This stage provided an even sharper and more radical shift, but it also appears to have its limits of qualitative transformation. We could continue to develop quantitatively, but the forces awakened during the second leap, primarily industrial ones, do not allow us to hope for this. If the same approaches are maintained, our technogenic civilization will perish rather quickly – in agony and convulsions.

Staying in place in the civilizational sense is hardly a feasible task, although this is seriously thought about and seriously talked about. The concept of zero growth, zero environmental impact and the like are proposed. However, there is a contradiction of these programs that is universally and philosophically understandable and accepted by us: what does not grow, dies.

In the 21st century, the last point may be set for our human civilization in the experiment that has been lasting on Earth for thousands of years, similar to one in a Petri dish, only not in a local but in a planetary ecosystem. In a short time, having eaten limited resources and polluted the entire

space with the wastes of its vital activity, the mold inevitably dies. The main reason is that there are no circulations of substances, energy and information in the cup, and there are no trophic (food) chains, when one species of living organisms feeds on other species and their wastes. As a result of similar processes that have been going on continuously on the planet for billions of years of evolution, the main biospheric wastes – soil humus and atmospheric oxygen – are formed. A dead Petri dish returns to its original dead state according to the second law of thermodynamics – the increase in entropy of any enclosed system.

2.2. Social Engineering and Pseudo-Problem of Global Overpopulation

The critical state of the environment and limited amount of resources force government and business to direct engineers towards the development and mass implementation of systems that serve the interests of only a limited number of people. A future in which more than 7 bln people may be genocided, is being built by the hands of engineers.



New achievements are designed to retard development, weaken health, reduce fertility, etc. Not directly but indirectly, engineers use their knowledge and skills to create instruments of mass murder. In fact, they find themselves in the situation of those specialists who designed crematoria and gas chambers in concentration camps. The motives dictated and imposed from above are also very similar. It is again about the struggle for living space.

There are almost no places left on Earth where humans have not set foot on. The planet's population is constantly increasing, while the populations and diversity of other species of living beings are, on the contrary, decreasing. Scientists claim that the growing consumption of resources is exhausting the capacity of the natural environment. Some assert that in the near future this will cause irreversible consequences – environmental catastrophes, wars, famine and possibly the complete extinction of humans as a species. But is this really the case? Have we reached the limits of possible growth? Or is someone trying to convince us that we have? What is the problem of overpopulation? What is the history of its study? And what is behind it?

In 1798, the Englishman Thomas Malthus anonymously published a small book "An Essay on the Principle of Population". The priestly scientist was interested in two questions:

- 1) what causes are holding back humanity's development and increasing its prosperity;
- 2) how these causes can be eliminated.

Malthus' answer strikes his contemporaries with its simplicity and cynicism. The reason lies in the constant desire of all living creatures to multiply faster than the amount of food at their disposal allows them to do so [14]. In the absence of war and disease, humanity reproduces too quickly. Its number grows exponentially, while the increase in agricultural productivity can only occur in arithmetic progression. When the number of people exceeds the land's ability to feed them, there are riots, wars and other upheavals. It is this circumstance that hinders the development of society and the improvement of people's lives.

No matter how much food people produce, there will always be even more eaters. Moral abstinence could remedy this, but the common people, who constitute the majority, are incapable of this. It follows that a prudent ruler who wants peace and tranquility for his citizens should keep them in a state of semi-starvation by not giving more than is necessary to sustain life. Mercy for the poor will only lead to an increase in their number. The task is not to find a way

to feed the surplus population but to reduce its number as much as possible by one means or another.

A classic example used by the proponents of Thomas Malthus' doctrine to prove his point is the Irish famine. In 1844, more than a third of the country's potato fields were infested with parasites. The harvest was enough to survive the winter, but the next year the situation worsened. The Irish had to plant sick or poor-quality tubers. The new crop was even worse than the previous one. Farmers couldn't afford to pay their workers. Landowners found it more profitable to graze cattle on their Irish land than to lease it to peasants who were unable to pay under the circumstances. More than 2 mln peasant tenants were forced off these lands, left without a source of livelihood.

People went to the cities, but there they faced other problems. The government tried to provide at least some income by hiring the most enduring people for construction work. However, the winter of 1846–1847 was unusually cold, and outdoor labor became impossible [15]. The money allocated to help the poor was exhausted within two years of misery. Epidemics began. People were mowed down by typhus, dysentery, scurvy. More than a million died of hunger and disease. An equal number emigrated to Canada and the United States on old dingy ships, which were nicknamed "floating coffins". In overcrowding, without medicine or enough food, only 8 out of 10 of those who traveled 5,000 km across the ocean made it to the New World. In total, the population of Ireland halved from 8 mln to 4 mln. Thomas Malthus' admirers cited overpopulation as the main reason for this, which allegedly led to the fact that crop failure turned into famine.

The teachings of Thomas Malthus have had a tangible impact on economic science and world politics. It has even been argued that Darwin's theory may have been inspired by these ideas. At least, the essence of today's commonly accepted view of the evolution of nature coincides with what Malthus said about the development of society: "There is not enough for everyone!" Therefore, conflict is the most global and profound phenomenon, the true driving force of life in all its manifestations.

In relation to society, such a concept is represented in Social Darwinism. Struggle, natural selection and survival of the most adaptable organisms are the main concepts of doctrines of this kind. In modern history, under the influence of Malthusianism and Social Darwinism, Hitler's idea of "living space" was formed. It became one of the main triggers of the conquest policy of the Third Reich.

Whereas in Germany in 1871 there were 56 inhabitants per 1 km², in 1910 – 120. Before World War I, the country was constantly deficient in agricultural production: 28 % protein deficiency, about 20 % calorie deficiency; food supply crises also continued in the 1930s, turning into a real nightmare for Hitler.

"The annual increase of population in Germany amounts to almost 900,000 souls, – wrote the German Führer on the pages of "Mein Kampf". – The difficulties of providing for this army of new citizens must grow from year to year and must finally lead to a catastrophe, unless ways and means are found which will forestall the danger of misery and hunger... Therefore, the problem was: a policy of territorial expansion or a colonial and commercial policy... The sounder alternative, however, was undoubtedly the first. The principle of acquiring new territory, on which the surplus population could be settled, has many advantages to recommend it, especially if we take the future as well as the present into account" [16].

Hannah Arendt, the founder of the theory of totalitarianism, believed that Hitler's racist ideology was directly derived from Darwinism, which in turn was linked to the ideas of Malthus. Indeed, if the essence of all social and historical processes consists in the struggle between their participants for limited means of existence, then sooner or later one of the parties, represented by nation, class, race or any other group of people, will proclaim itself the chosen one, for some reason inherently superior to the other and therefore worthier for survival. It is Darwinism, by virtue of its apparent neutrality, which is obligatory for science, that legitimizes the old, universally understood doctrine of "power is right".

Thus, the following has been scientifically substantiated:

- 1) in foreign policy – the right to seize resources and territories from other nations;
- 2) in domestic policy – the right to seize property and land from disfavored members of society: class, ethnic or religious groups.

Subsequently, complex ideological concepts, replicated by propaganda, were adapted to society's demand for the redistribution of a limited number of benefits. They became so deeply rooted in the consciousness of people that some Jews, for example, were willing to accept their racial inferiority and death as something necessary for the good of society. They obediently lined up to the gas chambers and machine guns, even though they could not help but guess, and sometimes even knew exactly what

awaited them. History has shown the horror of such beliefs and at the same time has disproved them.

Hitler's fears of famine awaiting overpopulated Germany, which cost the lives of tens of millions of people, turned out to be futile. In the 1950s–1960s, the so-called Green Revolution [17] took place in Europe. It was associated with the development of more effective plant varieties and their introduction into production, the expansion of irrigation, the application of fertilizers and pesticides as well as the use of modern technology. After that, 4–5 % of German farmers was enough to meet more than 70 % of the country's food needs, and their share in the gross national product was negligible compared to prewar times. On the other hand, the second half of the 20th century is a period of a sharp increase in inequality between poor agrarian and rich industrialized countries. Against this background, the doctrine of Thomas Malthus not only did not disappear from the intellectual horizon but, on the contrary, found a second life in the form of neo-Malthusianism.

Neo-Malthusianism refers to the promotion of birth control measures taken by many modern states. It also includes mass introduction of contraception and legalization of abortion, promoted by various public organizations around the world since the beginning of the 20th century. An important role in this work was played by representatives of the women's rights movement in Europe, the USA and Japan. Among the most famous neo-Malthusians are Michael Postan and Carlo Cipolla. They believe that social and economic conflicts are a consequence of demographic overload. The concept of overpopulation of the planet is emerging.

In 1972, at the request of the Club of Rome, which unites representatives of the world financial, political, cultural and scientific elites, specialists of the Massachusetts Institute of Technology prepared the famous study "Limits to Growth" [18]. The purpose was to determine the possible limits of economic and demographic growth of civilization due to the fact that the natural resources of the planet are not infinite. It resulted in the thesis claiming that it is necessary to reduce population growth to solve global problems. Based on the report, the concept of "golden billion" emerged – this is the number of people that can live on Earth without causing it irreparable damage. The rest should either disappear or live on the edge of poverty, being socially and economically isolated from the "chosen ones". In the same period, the concept of the "Malthusian trap" emerged – a situation in which population growth overtakes the growth of subsistence production.

A terrible example cited as an illustration to the notion of the Malthusian trap is the genocide in Rwanda in 1994, resulted in about a million people killed [19].

Rwanda is one of the most densely populated countries in Africa. However, agriculture there is still conducted using primitive methods, almost without the use of mechanization. It is not possible to achieve large yields, even despite the initially high fertility of soils.

This is how the authoritative American scientist Jared Diamond described the situation: "The whole country looked like a garden and banana plantation. Steep hills were being farmed right up to their crests. Even the most elementary measures that could have minimized soil erosion... were not being practiced. As a result, there was much soil erosion, and the rivers carried heavy loads of mud. One Rwandan wrote me, "Farmers can wake up in the morning and find that their entire field (or at least its topsoil and crops) has been washed away overnight, or that their neighbor's field and rocks have now been washed down to cover their own field." Forest clearance led to drying-up of streams, and more irregular rainfall. By the late 1980s famines began to reappear. In 1989 there were more severe food shortages resulting from a drought, brought on by a combination of regional or global climate change plus local effects of deforestation" [20].

Despite the fact that virtually every square meter is cultivated in this country, "a median farm size of only 0.89 acre in 1988, declining to 0.72 acre in 1993. Each farm was divided into (on average) 10 separate parcels, so that farmers were tilling absurdly small parcels averaging only 0.09 acre in 1988 and 0.07 acre in 1993" [20]. These average figures, revealing in themselves, conceal a huge number of problems. Naturally, first of all, land was not distributed equally. There was social inequality, which has increased over time. However, both the poor and the rich in this country had almost nothing. A farm of only 1 ha was considered very large. Little farms were as small as 24 ares (1 are is equal to 100 m²), which was an extremely small area per family in the absence of mechanization and the relentless depletion of land year after year. In fact, it is believed that the minimum amount of land needed to feed one person is 6 ares. At the same time, poor farmers with small plots mostly had no additional income, such as trading, sawing trees, making and selling bricks, working on construction sites, etc.

Due to the lack of free land in the community, young people could not leave their families and start their own households. By 1993, 100 % of men aged 20–25 continued to live

with their parents. On average, 5–6 people fed from one such farm, getting no more than 77 % of the required (by the most modest Rwandan standards) calories. Almost half of the country's population was on the verge of starvation. There were many other points of tension in the society. Parents were unable to provide for their children, who in turn were in conflict with each other over the right to land plots, resulting in constant quarrels over inheritance. The relations between neighbors were complicated as well.

Against this backdrop, the class-ethnic conflict between the two peoples of Rwanda (Hutu and Tutsi) lasted for decades, with periodic bloodshed. With the outbreak of the civil war, the tension between them reached its climax and culminated in massacres committed with great brutality. Although formally the aggression had the character of genocide against the Tutsi, the reality was different. Let us quote Jared Diamond again.

"The distinction between Hutu and Tutsi is not nearly as sharp as often portrayed. The two groups speak the same language, attended the same churches and schools and bars, lived together in the same village under the same chiefs, and worked together in the same offices. Hutu and Tutsi intermarried, and (before Belgians introduced identity cards) sometimes switched their ethnic identity. While Hutu and Tutsi look different on the average, many individuals are impossible to assign to either of the two groups based on appearance. About one-quarter of all Rwandans have both Hutu and Tutsi among their great-grandparents... This intergradation gave rise to tens of thousands of personal tragedies during the 1994 killings, as Hutu tried to protect their Tutsi spouses, relatives, friends, colleagues, and patrons, or tried to buy off would-be killers of those loved ones with money. The two groups were so intertwined in Rwandan society that in 1994 doctors ended up killing their patients and vice versa, teachers killed their students and vice versa, and neighbors and office colleagues killed each other. Individual Hutu killed some Tutsi while protecting other Tutsi. We cannot avoid asking ourselves: how, under those circumstances, were so many Rwandans so readily manipulated by extremist leaders into killing each other with the utmost savagery?" [20]. The scientist's answer is that Rwanda was caught in a Malthusian trap, meaning it was necessary to get out of it one way or another.

However, Jared Diamond recognizes that demographic situation alone would not have had such dire consequences as the genocide. The Hutu elite who seized power used the plight of the people and the accumulated resentments among them to strengthen their own positions.

They resorted to a variety of tools, including deliberate provocation and, of course, propaganda. The latter had such a powerful effect that, as in Hitler's Germany, people subsequently accepted the tragedy as a necessity and found thousands of explanations for it. Diamond quotes a local resedent who lost his wife and four children in the genocide. In his opinion, the reason was not the order given by the "elite" bathing in luxury and struggling for power, but the fact that "the people whose children had to walk barefoot to school killed the people who could buy shoes for theirs" [20]. However, such a thing would not have happened if the authorities had not armed one part of society against the other and legalized the killings. Therefore, the reference to Malthusianism, as in the case of the famine in Ireland and the threat of famine in Germany, is nothing more than an attempt to justify unnatural cruelty by natural causes.

Some European countries have population densities around the same level as Rwanda and, for example, Monaco and San Marino have significantly higher densities. As of data for 2018, Rwanda has almost as many people per 1 km² as the Netherlands. In the African country it was 420 people, while in one of the most prosperous European countries this figure is 402. It turns out that it is not at all about the number of people and the land they live on. In the modern world, and even more so in the future, this factor will continue to play an important role, but it can be largely compensated by other circumstances. Technical equipment, economic and political organization of the society are decisive.

Even Karl Marx argued that social disasters are caused not by quantitative territorial and demographic conditions but by the methods of production and distribution of products. Analyzing the famine in Ireland, he saw the main reason not in the fact that there were too many people in the country but in the fact that landowners simply drove people off the land, believing that it would be more profitable for them. However, as a result of the country's population almost halving, the live of Irish people didn't significantly turn for the better. According to Marx, capitalism makes a large part of the working class redundant and leads to the impoverishment of the proletariat even without population growth. Increasing the reserve army of the unemployed is a necessary condition of capitalist production because it creates pressure on workers forcing them to sell their labor at a minimum price, which allows the owners of industries to obtain a greater surplus value of production and increase capital.

Convincing arguments against the Malthusian theory were offered by representatives of the so-called new institutional school. Analyzing the reasons for sustainable economic development in European countries, when population growth was accompanied by an improvement in living standards and income growth, they concluded that the main reason for this was a change in the distribution way of the labor results. According to their understanding, the plague epidemic that occurred in Britain in the 16th century not only reduced the number of people but also weakened the institutions of serfdom. Peasants were able to retain more of their crops for themselves than before. Then, after the Glorious Revolution of 1688, England moved towards the development of pluralistic institutions, which allowed ordinary people to participate in the country management and earn income from their enterprises (including patents for inventions). This was just the reason for the beginning of industrialization, as a result of which the laws discovered by Thomas Malthus ceased to work.

The Malthusian theory has proved to be true only for societies in which a significant part of income is appropriated by a small group of people who constitute the "elite". Under such conditions, the majority of people have no interest in increasing labor productivity. The product will be appropriated by others anyway. Only a fair (at least relatively) distribution system can make the masses work more efficiently. In this case, the creation of conditions that motivate to produce more output leads to a constant increase in labor efficiency, and population growth does not turn into a decrease in living standards. Nevertheless, Thomas Malthus' idea is very tenacious and is only gaining popularity.

The problem of overpopulation in the 21st century is considered to be one of the main challenges along with climate change, global warming and biodiversity reduction. This subject is actively discussed by well-known politicians, international organizations and mass culture.

Back in 2007, Boris Johnson, still just a politician, who became the Prime Minister of Great Britain in 2021, called overpopulation "the real number one issue" [21]. The Great Reset program announced in 2020 by Prince Charles and the delegates of the World Economic Forum in Davos, although does not directly set the task of reducing the world's population but obviously implies it. It is quite clear: it means that the representatives of the countries whose inhabitants belong to the "golden billion" will reduce the population of those countries that are not among the chosen ones. Thus, if we call spade a spade, there are plans for social engineering or a new form of genocide, which humanity may face in the 21st century.

Fortunately, Malthusian ideas are not shared by everyone. This gives us hope.

Under to the UN report presented in 2019, the population growth rate is constantly decreasing. Thus, by 2100, this indicator will finally stabilize at 11 bln people [22]. According to the University of Washington projection, published on July 14, 2020 in the medical journal *The Lancet*, the world population will peak in 2064 and reach about 9.73 bln and then decline to 8.79 bln by 2100, which is 2 bln less than the 2019 UN projection [23]. Researchers at the Fraser Institute in Canada tend to believe that overpopulation of the planet and the danger of resource depletion are myths because technological advances have made resources more accessible and abundant than ever before [24]. Dr. Heather Alberro from Nottingham Trent University stated that the subject of overpopulation is an attempt to hide the true source of all environmental problems of our time. It lies in "the waste and inequality generated by modern capitalism and its focus on endless growth and profit accumulation" [25].

The representatives of the world capitalist elite are not interested in neither any fundamental changes in the system nor in the search for new directions and ways of development, but wish above all to preserve their position, increasing their power and capital if possible. This pseudo-elite (it so happened historically) was spontaneously and randomly assembled from politicians, bankers and rich merchants. Among them there are no engineers or, at least, philosophers, capable of complex and systematic thinking on the planet's scale. So, according to their professions and views inherent to their competences, they will lead our civilization only to the place where here and now it is possible to get fabulously high profits on global problems of humankind – not for everyone but for them in the first place. Some of the most radicalized researchers even assert that corporations are artificially restraining space exploration because space projects lead to an increased role of the state, which goes against their interests. "Therefore, globalists, on the one hand, need to take charge of the process of space exploration and profane it. This task is performed by PR illusionist Elon Musk with his unprofitable companies that exist on American taxpayers' money. On the other hand, they should eliminate the reason for the need in space projects. It is necessary to provide the inhabitants of Earth with enough living area on their home planet. It is impossible to enlarge the planet" [26]. On this basis, the idea of combating overpopulation is promoted.

This program is well-funded, has an impressive lobby at the highest levels of decision-making and a huge resource in the form of scientists and engineers who serve capital, inventing and developing ever more sophisticated ways of slow, as stealthy as possible, yet efficient and the most widespread genocide in the history of civilization. The realization of such a plan could be the end of this history. Just as Hitler's war unleashed for the interests of Germany led to the destruction of the country, so the pseudo-elite, opposing itself to all others, will eventually destroy itself, making our world unfit for human life. At the reckless pace of development of Earth's industry achieved by the end of the 20th century, humankind has a couple of generations left before the point of no return. However, it may be too late if nothing happens in 30, 40 or 50 years. Then, the gun called Industry, hanging on the wall of our house named Biosphere, will fire a shot at the head of the self-murderer, Human Civilization.

The problems of exceeding the limits of growth and overpopulation of the planet, presented by globalists since the 1970s as the main ones for humanity, are a smoke-screen behind which they hide other real problems, namely, the problems of the limits of growth of capitalist production and the limits of its human capacity.

Capitalism is a system in which the few thrive at the expense of the many; the center is enriched by using the resources of the periphery. The basis of the future postcapitalist system is that it will not be for everyone either. This "brave future" is intended (which is carefully hidden) only for the "brilliant million", next to which the "golden billion" of digitized indentured servants, i.e., bio-digital convergents, will "subsist" while serving. This is on the one hand.

On the other hand, the automation of production leads to the fact that for capitalism the labor needs come down to rather low figures. Those involved in production are useful. They get paid for their work, and they are also consumers. But the remaining several billion are something like annoying parasites that need to somehow, more or less, be alimented, and who, on top of all, pose a real threat to the system: if there's anything, they can rebel at any time.

The more population there is that has to be fed by the capitalist system, the more unstable it becomes. This is what the Marxists called the main contradiction of capitalism: the contradiction between the social nature of the production process and the private capitalist form of appropriation of the results of labor. That is, everyone exists within the system, but only a few can live well, and the more there are those who cannot, the more likely it is that this poor majority will overthrow and destroy the rich minority.



That is why when the "global elites" talk about overpopulation, they are not at all concerned about the depletion of the planet resources – in fact, they know that there are technologies today that may solve this multicomponent problem. This is how they take care of the preservation of their wealth and dominant position. This is the real meaning of "sustainable development" for them. They play with concepts to achieve their real goals. When it comes to the limits of growth for capitalism, they talk about the limits of growth in general and find ways how to achieve their goals and at the same time also make money on this. This is their black magic. This is the plan of the global pseudo-elites.

Therefore, a "new reality" is systematically being formed with a "new serf" – a human-like creature without properties who is easy to control and manipulate, at the level of animal reflexes, namely: asexual and soulless, without historical memory and without identity, without conscience and without morality, without a family and without children, without the meaning of life and without goal-setting (except for the sense of consumption, and not so much real as virtual and emotional).

One should not see in these plans any sort of plots and conspiracy theories. There is no conspiracy. "Global elites", by masking our faces, the faces of billions of people around the world, unmasked theirs. They do not hide their intentions, they talk about them openly. Anyone can see for themselves. One has only to set a goal and spend a little time. For example, you can read the book "COVID-19: The Great Reset" and other works by Klaus Schwab [27, 28] – one of the ideologists of globalists and permanent head of the World Economic Forum in Davos. Below are just a few quotes.

"The world will no longer be the same, capitalism will take on a different form, we will have completely new types of property in addition to private and state. The largest multinational companies will take on more social responsibility, they will be more actively involved in public life."

"Governments must also adapt to the fact that power is... shifting from state to non-state actors, and... to loose networks. ...Increasingly, governments will be seen as public-service centers."

"...The greater population growth is... the higher the risk of new epidemics."

"...If both democracy and globalization expand, there is no place for the nation state."

"...The containment of the coronavirus pandemic will necessitate a global surveillance network."

And so on... For example, the Prime Minister and Prince of Great Britain, US President Joe Biden and others have

not hesitated to declare their agreement with Schwab's theses [29]. Obviously, the heads of transnational corporations will also not be against such a program that clearly expresses their interests.

In support of the above, we can refer to a detailed analysis of the utter futility of the socio-economic vector along which our civilization is developing, led by "deep power", as conducted in numerous works and speeches in the field of economics, nature management, ecology, sociology and politics of such independent researchers as M. Khazin, V. Katasonov, O. Chetverikova, A. Fursov, V. Boglaev, I. Shnurko, A. Dugin, S. Pereslegin and others [30, 31]. I became thoroughly acquainted with their views as well as their analysis of the world situation, our past, present and foreseeable future during the pandemic, while in partial self-isolation at our innovation center "EcoTechnoPark".

The developers of the Great Reset program actually plan to zero out the technocratic vector of human development, formed over many previous millennia, as well as to zero out the human technogenic civilization itself – the one we know and form part of. Beneficiaries of capitalism, whose crisis as a system by its socio-economic nature has taken place over the past several decades, are trying to camouflage it as the crisis of humanity – the planetwide technogenic society created in the era of capitalism.

"Global elites" led by the USA and Great Britain, by the hands of the world hegemon, are destroying and annihilating countries and nations. Iraq, Libya, Syria, Afghanistan are the states that did not want to walk the same road with them and therefore turned out to be undesirable. No one now even remembers the two atomic bombs dropped on Japan (although there was no need for it) or the Korean and Vietnam wars...

The destruction of civilization occurs not only directly but also implicitly. First of all, it is done through the environmental movement with quotas and bans introduced around it. Such measures are aimed at slowing down the industrial development of countries beyond the borders of the Collective West. Because of all kinds of environmental sanctions, it is too expensive for them to build and run factories. The growth of the economy slows down, and the standard of living and quality of life decrease. Earlier, in the days of Thomas Malthus, this factor was not a determining factor for the growth or decline of the human population, but now it is very important – all thanks to mobile digital devices and global informational monopolies.

There are already many studies showing that the proliferation of smartphones and access to information has a direct impact on a person's view of themselves, their life and how many children they should have. Looking through Instagram

and Facebook feeds, people see pictures of a "beautiful life" and set their sights accordingly. They strive for comfort, want to build a career and be successful, and the presence of a large number of children in these plans rather hinders than helps. Especially if the country's economy is not developing and does not meet the new demands. The whole chain looks devilishly graceful. Because of environmental restrictions, industry does not grow, the economy does not grow, but informatization flourishes, which together leads to a decline in the birth rate. This is exactly as the pseudo-elites want it to be. In this way they throw off the human "ballast" from the biosphere ship "Life on Planet Earth". In accordance with their idea of tomorrow, they deprive billions of people of their future – those who have already been born but will not give birth, and those who will not be born to please false satanic values and idols.

2.3. 5D Program

Humanity's way of life in the 21st century, along with the oppression of nature, is the cause of all past and future upheavals. All the wars and economic problems of the 20th century occurred because of overcrowding and a persistent desire to consume as much as possible, resulting in the escalation of the struggle for resources and spheres of influence. This struggle is one of the essential elements of a capitalist system based on profit and around profit.

In general, the capitalist system implies the need for and imminence of crises, each leading to more disastrous consequences. Most economic experts agree with this opinion. Currently, the knowledge about this has become widespread, right down to the layman's level. Accordingly, there is a demand for the reform of capitalism since the "global elites" do not accept alternative models, like socialism. After all, these are the capitalist elites, and they cannot disown themselves.

Since experts mainly associate crises with overproduction of goods, these crises can be avoided only if we change the nature of production and consumption. Before exploring how the "elites" intend to arrange the new world, it is necessary to understand how all this happened before, in the most general terms.

Enterprises manufacture goods, pay workers for their labor and keep the added value to spend on product development, plus their own needs, including their need to pay taxes. That said, the goal of production is to increase profits, which is achieved by optimizing technological processes, reducing the cost of labor and increasing the number of manufactured goods.

Therefore, the production volume should always increase, and the relative wages for labor should decrease. At the same time, workers are buying most of the products. If they earn less, they buy less. Yet, producers continue to create more and more goods and services. There are so many of them at some point, so nobody needs them, and the manufacturers cannot sell enough products to pay off the investments. Then they opt for staff redundancy, assembly line shutoff and production minimization.

The economy sinks into crisis. Then someone goes bankrupt, someone optimizes something, prices drop for the accumulated surplus of goods, warehouses once chock-full of products gradually empty, and then there is a demand again that exceeds supply. Everything is repeated at a new round. Of course, a war or a pandemic can significantly mitigate the situation. In a short time, they create new market outlets, job opportunities, requests for specific product ranges, orders, etc. That is precisely the reason why wars begin at the moment the economy reaches its peak; it is not an effect of power excess but a way to avoid the upcoming steep and painful fall from the top. Is it possible to prevent crises in some other way? It is believed that yes.

It is assumed that it is possible to improve the capitalist system, to make its development not cyclical (from crisis to crisis) but sustainable. To do this, it is enough to arrange production and consumption in such a way that they are always balanced and orderly. Of course, not in the logic of a planned economy, but with the possibility of preserving the power and wealth of capitalists.

Digitalization should come to the rescue, being a digital transformation of society and the economy. Most notably, it's about internet technologies, big data processing technologies, virtual and augmented reality, artificial intelligence, 3D printing, printed electronics, blockchain, quantum computing, etc.

Digitalization will help to get total control and accountability: what and how much is in production, what and how much is purchased. It will also form the basis of a new (inclusive, in other words "universal") capitalism, where ordinary people will no longer own anything as private individuals; they will only have access to services. Because life will turn out to be unthinkable over time without these digital services, the demand for them will become constant, increasing in proportion to consumption without any fundamental restrictions (as everything starts to happen in a virtual digital environment, not in a limited world of material objects, there will be no restrictions).

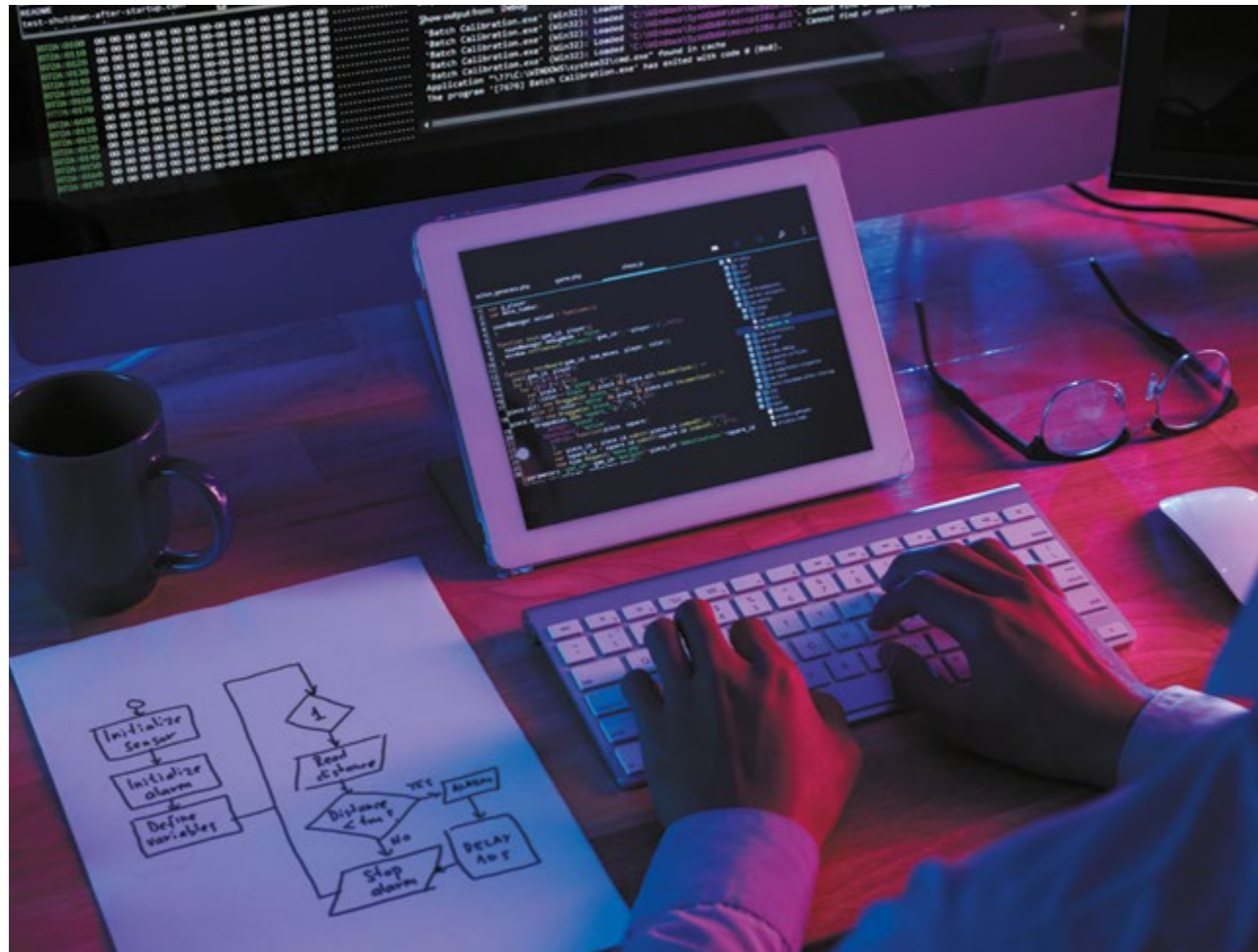

Digitalization is one of the five pillars on which a new world order is in the making. One can also speak of the four "Ds": desocialization, deindustrialization, decarbonization and depopulation. With their large-scale postcapitalist deployment, these vectors of development proposed by modern capitalism are likely to ensure the stable development of the system. However, this "brave new world" will turn out to be horrific from the point of view of 7 Bln people for whom there is no place. The substance of such plans is as follows.

Digitalization is the basis and is a dreadful tool within the logic it is developing today. It includes the following:

1) introduction of widespread accounting and control systems for production, services, banking and so on, which will lead, in the end, to the establishment of total control over the "wrong people" and the transfer of civilizational functions to supposedly smart but in fact to primitive artificial intelligence, which, from an engineering point of view,

is by several orders of magnitude below the complexity of the simplest microorganism structure, such as coronavirus;

2) accelerated introduction of bioengineering technologies, the mass production of robots, the promotion of genetic mutation projects and species crossbreeding as well as the interbreeding of people, artificial intelligence and machines, which will lead to a gradual transformation of the human personality into a soulless human-like creature, into a cyborg, a bio-digital convergent.

Desocialization is:

1) establishment of a new policy glorifying minorities (social, ethnic, racial, biological, gender, etc.) where they dominate over the majority;

2) subordination of humanity to liberal values, opposition to critical and analytical thinking of people, deprivation of privacy and civil rights, total censorship, complete control and manipulation of the media, social networks as well as

consciousness, ideology, education, science, culture, art and religion. After all, frail and dying capitalism needs primitive convergent consumers, not creative individuals. Moreover, there will be a gradual decrease in the role of nation states in society and the transfer of most of their functions to global corporations;

3) fight against natural childbearing, the elevation of bodily and spiritual ugliness and perversion, depravity and lust, mentally and physically disabled people to an ideal of harmony and beauty;

4) destruction of family and nation-states' institutions which must be replaced by global (supranational) corporations that have entered the totalitarian phase of their development;

5) expanding influence of transnational pharmaceutical corporations, Big Pharma, the likes of which are not interested in human health since only ill people can bring profit;

6) incremental and consistent introduction of a guilt complex into social consciousness during many decades that is a complex of personal and collective inferiority. We, ordinary people, who are the overwhelming majority, are forced on all continents to repent, to feel guilt, inferiority and faultiness at the slightest pretext:

- for the fact that we are not homosexuals;
- for the light (or dark) color of our skin;
- for our nationality;
- for eating meat and opposing genetically modified and artificial foods;
- for doubting the benefits of vaccinations and the existence of pandemic at all;
- for having mothers and fathers, for using "man" and "woman", "he" and "she" words;
- for being healthy and not disabled;
- for the fact we don't blindly believe in global warming and the carbon greenhouse effect...

The list of our "guilt" goes into infinity. In its social essence, it is a psychological terror unleashed on every person and humanity.

Society is gradually and consistently turning (or rather, it is being transformed) into a kind of turbulent, albeit skillfully managed, set of minorities dissatisfied with life, who initially, from early childhood, are offended by the "alien" majority. The majority of society, even to the detriment of its own interests, is obliged constantly to take care of these offended people. Moreover, the interests of minorities, including

their fanatical desire to dominate the majority, should not be questioned or criticized, otherwise this immediately falls into the category of racism, homophobia or xenophobia.

The fact that democracy, as it has been interpreted in the 21st century, is the power of the minority over the majority, was a revelation to me. Although it turned out that for the ideologists of the global liberal and capitalist system, this is an accepted and evident axiom. Such a perverted view, essentially turning everything upside down, reminds me of the story of a cancer cell that, with its "unconventional values", misleads and deceives the weakened immune system of a healthy organism with trillions of normal cells and ultimately kills its master by metastasizing into all organs and dies itself.

The displacement of small companies and industrial enterprises from the market will lead to the emergence of global monopolies, free to dictate any favorable conditions to the consumer.

The erosion of the functions of the state and their transfer to global corporations will lead to a revision of social policy and social hierarchy. For example, why pay pensions? And, in general, do corporations need disabled older adults and children, hospitals and roads or the entire social infrastructure? Consumption, childbirth and other manifestations of human life will have to be rationed by the new standards to support the "sustainable development" of the proposed "brave new world".

Reducing the importance and role of the state and its abolition is necessary for the beneficiaries of capitalism to pay fewer taxes. At the same time, it serves to increase the demand for goods and services provided to the population in many countries at the expense of these same taxes. I'm talking about removing the intermediary that reduces the efficiency of the capitalist system and adds unnecessary variables. In essence, the reanimation of Trotskyism should take place. Its idea is laid in a phrase: "The technology of establishing global power by eliminating the nation states and other organizations competing with the global power."

Desocialization and detaching from society makes everyone unprotected in the face of global corporations, depriving them of the hope of receiving help and support from loved ones who could pass on to them specific necessary knowledge, experience, goods or services. So, naturally, they will have to singlehandedly purchase everything they need. As the consumers, they become much more reliable and efficient from the standpoint of making a profit from them.

That is why, under various glib excuses, there is an accelerated elimination of competitors of global corporations – small and medium businesses, personal and private property – with the transition to a supposedly more “advanced” sharing economy.

Deindustrialization is:

1) redeployment of almost all sectors of the world economy into a vague and opaque sphere of environmentally safe production, plus the monetization of the environment to benefit elite of globalists. As a result, there is a widespread change from traditional nature conservation activities to environmental extremism;

2) accelerated reduction of industries and workplaces, creating a civilizational “digital concentration camp” with a global lockdown and payment of guaranteed basic remuneration, i.e., minimum “ration”, to those who do not work;

3) curtailment of the traditional (natural) production of agricultural products and a transition to genetically modified foodstuffs, in particular a defective composition and the quality of artificial meat, which could be dangerous to human's health. One of the main arguments is that a cow is allegedly more environmentally hazardous than a car and an airplane since it emits many greenhouse gases, including carbon dioxide and methane, that is why the humanity will be supposedly compelled to renege on beef in the near future.

Decarbonization is the rejection of hydrocarbon fuels (oil, coal, natural gas) and carbon dioxide emissions into the atmosphere, replacing them with technologies purported to be green but ineffective and environmentally even more dangerous.

Decarbonization and deindustrialization are interrelated elements of the same program. In a broader view, they refer to the monetization of ecology and its transformation into capital. For example, people and businesses must pay for what we need most, such as water and air, the value of which becomes part of the surplus value. As a result, the demand for this product will stabilize, reducing the risk of overproduction. On the other hand, the slowdown in industrial development is a high road to a decrease in the population's real income and, consequently, to a population reduction. It satisfies one of the goals of the “elites”, also known as **depopulation**.

The “sustainable development” thesis of the Club of Rome assumes an accelerated reduction in the world population to the “golden billion”, even down to 500 mln [18]. Hence is the special operation “COVID-19 Pandemic” with protective

masks and widespread lockdowns that destroy families, the immune system of people, voluntarily and forcibly placed in a “home prison”, and destroy medium and small businesses – the basis of the economy of any country.

Matrix RNA vaccination, yet to be adequately studied for long-term consequences, is supposedly the most “humane” self-imposed method, which logically fits into depopulation. Over time, this can lead to irreversible genetic changes in the vaccinated organism, negatively affecting the male and female reproductive organs. In its social essence, such “treatment” can be used, if necessary, as “velvet genocide”, i.e., prolonged murder. Although, most likely, we will never know when such “necessity” will come.

In the theories we've been fed, vaccination leads to collective immunity, although, in the documents of the World Health Organization, this is called “herd immunity”. Humankind is just a herd in which natural immunity, that is beyond the control of third parties and has been polished over billions of years of evolution of life on the planet, should be replaced by artificial immunity controlled from the outside. So, we get hooked on mandatory vaccination – a strong addiction to a lifelong intake of questionable vaccines, constantly mutating. It will become another step towards turning people into cyborgs.

Depopulation is necessary because capitalism is a social system that only needs a small number of people to function due to the automation of production and similar innovations. Moreover, an excess of human biomass is dangerous for the system since those individuals who are not involved in production will nevertheless need goods and demand them. Therefore, it is better to optimize the size of the population, even at its own expense, in such a way that it would provide sufficient volumes of demand and involve producing what it consumes. The people should be able to feed themselves and simultaneously guarantee an increase in profits and luxury to the “global elites” but nothing more.

Looking further and describing a transition that has already happened, theorists say that humans are no longer the primary consumer of products. The actual situation today is simplified: one company produces metal and sells it to a company that manufactures robots. Then the same metal producers and other companies buy those robots as, for example, machine tools. In the end, robots make robots for robots. Humans may not be involved in these processes at all. The world order described above is a global digital concentration camp, digital fascism. The system, offered to us as an image of an inclusive future, will be strictly ordered and self-sufficient.



The main difference between such a “brave new world” and the existing world order is “stability”, as opposed to cyclicity. That is why globalists repeat words “sustainable development” like a mantra, sounding as a spell from black magic. At the same time, they use every effort to pretend that their actions are motivated only by global environmental problems and concern for people. Of course, the motivations are different, but ecology is a good product and perhaps the best planetary business resource available.

I have found evidence everywhere that what is happening, including the coronavirus pandemic, is part of a deliberate and steadily implemented program. For example, Prince Philip, the husband of Queen Elizabeth II, one of the ideologists of the decrease in the planet's population, talking about his rebirth back in 1988, said: “In the event that I am reincarnated, I would like to return as a deadly virus, to contribute something to solving overpopulation” [32]. How much do you have to hate humanity to say such a thing?

On October 18, 2019, months before the announcement of the actual pandemic, the Johns Hopkins Center for Health Security, the World Economic Forum and the Bill & Melinda Gates Foundation held a pandemic exercise called “Event 201”. Business, government and medical representatives discussed the specifics of a coronavirus pandemic, which will spread from bats to humans. It was supposed that 65 mln people would die from the infection over 18 months. The pandemic would continue until an effective vaccine was born or the number of recovered individuals reached 80–90 %. At the same time, the world economy will collapse by 11 % [33].

Information about this is publicly available, a script, videos from the scene, final recommendations and more can be easily found. Although the exercise occurred months before the epidemic, the description of the situation came to fruition. An “esteemed” validity check expert, the British organization FullFact, refutes the assertion that the exercise

was a rehearsal for the COVID-19 pandemic. It is noteworthy that among the founders of FullFact are such companies as Facebook, Google and the Open Society Foundations of George Soros. Interestingly, the same platform gets credit for refuting a series of scandalous news stories directly or indirectly related to the pandemic, depopulation and the role of the "global elites" in them.

Such facts include a widely circulated online quote dating back to 2009 and attributed to former US Secretary of State Henry Kissinger: "Once the herd accepts mandatory forcible vaccination, it's game over! They will accept anything – forcible blood or organ donation – for the "greater good". We can genetically modify children and sterilize them – for the "greater good". Control sheep minds and you control the herd. Vaccine makers stand to make billions, and many of you in this room today are investors. It's a big win-win! We thin out the herd and the herd pays us for providing extermination services. Now, what's for lunch?" [34]. Kissinger, in 1974, prepared a secret report (Memorandum 200), which said that population growth in the least developed countries concerns US national security. Therefore, the proposal came forth to give paramount importance to ensuring birth control and downsizing the human population [35]. This document has formed the basis of the official policy of the United States since 1975, later declassified in the 1990s.

Regarding the rebuttals given by supposedly reputable organizations like FullFact, I believe this is part of an extensive information game in which IT corporations can play with the facts in any possible way. They banner whatever is convenient and do their bidding. If something is not profitable, they declare it fake, conspiracy or elements of conspiracy theories. Who can stop them when the media, social networks and search algorithms are all in their hands? They can even shut down the US President's account, as happened to Donald Trump. Shut up anyone they want. They can say anything, including calls for the physical destruction of entire states, their leaders and their representatives. That is what the Facebook management did when they announced that they would not block messages suggesting the assassination of Vladimir Putin, Russian ministers and the military. Whoever controls the information controls the world. They do today, which is precisely what biochemistry corporations do. Therefore, they may soon have as much total control over our bodies as they already have over our minds and senses today.

For 20 years, the "medical mafia" Big Pharma have been pursuing their goal to create a sustainable demand for their products within the framework of the new world

medical order, in which a person is just a subject for experiments, something like a guinea pig. A vaccine is most suitable for this because its demand does not depend on market conditions. To do this, you must scare all of humanity, all 8 bln people, with messages like "Get vaccinated! Or you will die." The demand has been secured for many years, necessitating the pandemic and a constantly mutating virus, combating which will require more and more vaccines. The coronavirus fits perfectly into this scenario, and obviously there was an order for it. Vaccine production plants have already been built all over the globe. It is obvious that no one intends to give them up, and this was a long-term plan. Again, a prominent figure among the lobbyists is Bill Gates. The principal investor in the pandemic announcer the World Health Organization, the primary owner of the corporation that supposedly invented the cure for the virus.

The prices of the vaccines that have become indispensable can be raised over time, providing long-term profits for the owners of the WHO. This organization has become an effective tool for extracting profit from each of us within the framework of another antihuman program, "Bio-Digital Convergence", which is being developed and successfully implemented by the "global elites" in the framework of the 5D program of gradual transformation of people into convergent cyborgs.

24. Pernicious Passion of Engineers for All Artificial Things

The central place in the 5D program is given to digitalization, which possibilities of implementation are related to the development of artificial intelligence. This relatively new phenomenon opens up amazing prospects. Applications for this tool are being sought in all areas, from household appliances to space exploration. And everywhere it is a question of finding a way to partially or completely replace humans with algorithms and the machines that execute them. Although this situation is formally and technologically new in many respects, it reflects the essence of our terrestrial engineering (industrial) civilization and embodies its characteristic attitudes.

The concept of "civilization" comes from the French *civilisation* (originally – the transformation of criminal proceedings into civil ones), then from *civiliser* – to civilize, from *civil* – civil, then from Latin *civis* – citizen [36]. Many people are familiar with the statement "*Civis Romānus sum!*" ("I am a Roman citizen!"). In Antiquity, it was a formula of self-assertion, the superiority of one group of people over all others as bearers of special rights and privileges.

Even the poorest Roman citizens received free bread and access to public spectacles and therefore remained the elite. On the other hand, such a special position was based on their inclusion in the legal system – a system of laws that applied only to the Romans and required a special court for them, while others were outside the law and deprived of any legal protection.

Civilization begins where the law appears. It is it (no matter whether formalized or conceptual) that regulates the relations inherent to a civilized community, which differ from relations based on instincts or personal experience of a single individual in the animal world. At first, it is a law of tradition or nature, then – a legal law that has not only a limiting function but also contributes to the transfer of practically valuable knowledge. The procurement of fire, the manufacture of tools – the entire material basis of civilization rests upon knowledge of the laws of nature and the implementation of the algorithms of actions prescribed by them. The law and the algorithm as a sequence of operations are largely identical concepts. The Latin word *lex* (law) in one of the meanings is the order of actions [37].

The main mechanism of self-preservation and development of civilization is the maintenance of those engineering (industrial) technologies that lie in its foundation. Without hunting and gathering technologies, tanning hides and fire procurement as well as without other algorithmic actions, the rules of which are preserved and passed down from generation to generation, social development as an increase in the level of complexity of the organization of society would be impossible. The ordering tool in this regard is certain algorithms that subjects in civilizational processes obey. So, the laws of primitive tribes were built around the need to maintain fire. The industrial society serviced the machines. A person of the 21st century becomes at the service of artificial intelligence: performs functions related to the development of computing machine capabilities, the expansion of its fields of application as well as its maintenance, while simultaneously being a consumer of digital products. Here, in the process of alienation of labor described by Karl Marx, a new dimension opens up.

Until now, the alienation of labor has been built up in several stages: alienation from the instruments of production (they are owned by the capitalist, not the worker); alienation from the results of activity (products do not belong to the worker); alienation from the processes of performing physical labor procedures and from one's own physicality (the human body actually turns out to be part of industrial equipment). This was followed by alienation

from the ancestral essence (from ties with ancestors and relatives, with whom neither the land as an object of labor nor the ownership of tools of labor are no longer united) and alienation of people from each other. With the advent of artificial intelligence algorithms, a person became alienated from the elements of thinking and conscious abilities, from their own individual mind. Let us designate such a phenomenon as the calculator effect not only because these electronic devices quickly and qualitatively process numbers and perform complex computational operations (in its engineering essence, any computer is just a powerful calculator) but also because they are all the same – depersonalized, like any other machine.

2.4.1. Calculator Effect

The calculator effect is that in the process of performing mental operations, such as counting, some actions are carried out by a mathematical (digital) algorithm instead of a person. As a result, thinking becomes fragmented. In the course of forming a concept of the object, which cognition is basically the purpose of thinking, the essential stages end up missing out. The concept of the world becomes devoid of integrity, as the person themselves is alienated from thinking. Interestingly, one of the most successful brands of calculators is called Citizen. The word is derived from the Latin *civitas* (city), which goes back to the same roots as *civis* (citizen) and *civilisation* (civilization). The calculator is the same machine algorithm that replaces the individual in their main component as a biological being endowed with intelligence – the ability to think.

The described effect applies not only to computing activities. Algorithms are integrated into absolutely all mental operations: comparison, analysis, synthesis, abstraction, generalization. Getting to the destination, people use a navigator and may not even think about which part of the city they are in. There is a case when Japanese tourists in Australia drove a car into the ocean, although they planned to get to an island near the shore. They followed the navigator's instruction [38]. Similarly, when reading the news and searching for the right information, people are increasingly being led by algorithms that record our preferences and issue recommendations for studying only those topics that, from the viewpoint of artificial intelligence, may be of interest to the consumer.

In communication, people are increasingly replacing entire blocks of conversation with videos and memes. Algorithms make coffee, do the cleaning, build cars and are already learning how to drive them, launch rockets into space

and in seconds process volumes of data that humans won't be able to cover even in a lifetime. With the emergence of new technologies, society became more powerful, but there was less and less space for the individual in their natural manifestations. Let us call it the paradox of a civilized person. The less they are, the better and more powerful they become. We fulfill the laws the better, the more we subordinate our lives to them. For an ideal performance, it would be good for us to disappear altogether – first reducing to the "golden billion", then to the "diamond million", which will then inevitably degrade as a society and become zero.

24.2. Natural and Digital Thinking

Civilization comprises a setting to replace the individual with algorithms and machines because human is a natural being. In the same way, asphalt replaces grass; tractors and cars replace horses; communication on the internet replaces live contact. Civilization aims to replace the natural with the human-made. The creation of artificial intelligence is a necessary stage in the development of the so-called civilized (but by no means civilizational) community. And the root cause is technology and engineering technologies being at the heart of everything. They exist according to the same principles as Live Nature (living organisms), having raw materials and energy at inputs and useful products (services) and technological waste at outputs, while following the scheme: (raw materials + energy) – product (service) = waste. The difference is that the waste of technical production cannot be used by technology or life to the fullest, as it happens with the waste of living organisms.

The entire biosphere, with human being only a small part of it, is formed from life waste: biohumus, which contributes to the fertility of previously lifeless soils; oxygen, which we breathe and which ensured the creation of an ozone layer saving life on the planet; carbon dioxide, thanks to which a greenhouse effect appeared, which increased the average temperature on the planet by 32 °C, without what neither the biosphere nor us would exist, since all the oceans would remain covered with ice [39]. In contrast, the technosphere's waste products damage the biosphere because they are poisonous antagonists and take away the space that previously belonged to it – in the air, water and soil.

Thus, any technogenic civilization (terrestrial humankind is no exception here) not only replaces Live Nature but also fights with it and destroys it – first on the material level and then on the spiritual and social ones. By the same logic, material and informational raw materials turn into digital

products as well as into material and informational waste, which increasingly fills up the living space and living thinking with digitalization.

The raw material for thinking is information or data (quantitative and qualitative). Through their processing, we form perceptions, beliefs, knowledge, worldview, goal-setting and array our actions on their basis. The by-product of thinking (waste) is also information, i.e., a digit. However, it undergoes changes in the thinking process. Compared to the informational raw material, informational waste changes its structure considerably, becoming organized according to the formal parameters of cognitive activity. Similarly, raw materials change their structure in technological cycles. For example, coal is used to produce such a product as heat and electric energy. The waste will be flue gases, ash, slag, sludge, etc. The chemical elements that make them up were also contained in coal, but now they are structured and correlated differently. At the same time, if coal (a former tree that lived on the planet hundreds of millions of years ago) first existed as a matter harmoniously integrated into nature, then from the moment of its extraction and through changing its structure, we get substances that violate the natural balance.

A similar process in nature does not lead to similar results. Waste products of all living organisms in the planet's biosphere are effectively integrated into food chains that end up in the fertile humus of the soil and then start again in the same soil on a new life cycle. The situation is approximately the same when comparing natural thinking with the digital one.

Natural thinking is the activity carried out directly by the human brain. Digital thinking is the work of computer algorithms. The specific features of the waste or by-products of the former are as follows:

- they can remain absolutely unfixed;
- the energy used to produce them is of natural origin and embedded in the natural energy exchange;
- once fixed, they can be efficiently incorporated into the thinking processes of other subject.

The specific features of the by-products of digital thinking:

- they are mandatorily recorded on digital media;
- the energy used for their production is of artificial origin and violates the natural energy exchange established in the Earth's biosphere;
- a significant part of them is not integrated into the thinking processes of the subjects of natural thinking

but, on the contrary, disrupts and destroys them, which is described in detail above through the "calculator effect" concept.

The algorithm that generated the Cosmopolitan magazine cover required the neural network to complete the task, based only on the text description as input data: "...wide-angle shot from below of a female astronaut with an athletic feminine body walking with swagger toward camera on Mars in an infinite Universe, synthwave digital art" [40]. In addition to the cover itself, which the research team found to be the most successful, at least a dozen other images were created. This is waste. Electricity was used to produce them. They are of no use to anyone and will never be used. Nevertheless, they occupy space on a server or computer hard disk, can be thrown into the internet and there, along with the necessary and important information, will turn out to be just noise, an obstacle for searching the necessary material. In other words, they become noospheric informational garbage that invades the processes of natural thinking and pollutes it in the same way as the wastes of technological production pollute the biosphere.

24.3. Informational Garbage

The result of the fact that human has begun to transfer a significant part of thinking and creative operations to the algorithms of artificial intelligence for execution is the overflow of the information field with informational garbage. This leads to the degradation of natural thinking in the same way as the destruction of the biosphere is caused by its oversaturation with material wastes of the technosphere.

Informational garbage produced by the subjects of natural intelligence mostly appears when digital algorithms are included in the thinking and creative processes. Thanks to them, the creation of intellectual products is considerably facilitated: computer programs correct grammatical errors, can independently compile texts, perform graphic processing of images, make collages and perform editing of visual data, process and generate new sound tracks. Since the creation of an intellectual product appears to be greatly simplified, its quantity may exceed the actual needs. As in technological process: a product that is not consumed turns out to be a by-product, ceases to be a product and becomes waste.

The processes of creating non-disposable waste of thinking are cumulative. On the other hand, the products of natural thinking are forced to compete with the products of digital thinking. This is another mechanism for replacing the individual.

Eventually the individual may be completely displaced. Firstly, there will be no need for the products of his thinking and creative abilities. Secondly, these abilities themselves will be unsuitable for efficient work under new conditions. In the abundance of informational garbage, humankind risks being unable to find the informational raw material necessary for thinking.

24.4. Mechanisms of "Escape from Freedom" in Industrial and Postindustrial Society

In the society of the 21st century, there is optimism about the expansion of artificial intelligence. There are involved the same mechanisms, which Erich Fromm defined as "escape from freedom" [41] and which earlier caused the emergence of totalitarian regimes and now may result in the emergence of a new type of social order – digital totalitarianism or digital fascism. Before describing it, let us cite a few quotes by the German sociologist referring to the processes and mental states that lead to social unfreedom and alienation from mind.

"The new freedom is bound to create a deep feeling of insecurity, powerlessness, doubt, aloneness and anxiety. These feelings must be alleviated if the individual is to function successfully" [41]. For the most part, people "cannot go on bearing the burden of "freedom from"; they must try to escape from freedom altogether unless they can progress from negative to positive freedom. The principal social avenues of escape in our time are the submission to a leader, as has happened in Fascist countries, and the compulsive conforming as is prevalent in our own democracy," Fromm writes [41]. "Often he is well adapted only at the expense of having given up his self in order to become more or less the person he believes he is expected to be. All genuine individuality and spontaneity may have been lost" [41]. "By becoming part of a power which is felt as unshakably strong, eternal and glamorous, one participates in its strength and glory. One surrenders one's own self and renounces all strength and pride connected with it, one loses one's integrity as an individual and surrenders freedom; but one gains a new security and a new pride in the participation in the power in which one submerges. One gains also security against the torture of doubt" [41].

The above quotes describe the situation in the 20th century that led to the emergence of fascism in Europe. However, all these statements and observations are also true for the 21st century. The difference is that it is not the state, a political party with its ideology or a great personality of a leader but the algorithms of artificial intelligence and digital

technologies lying at their basis that act as an "unshakable eternal and beautiful force". The individual of the 21st century, who in liberal countries is provided with a great negative "freedom from", being unable to transform it into something positive, is ready to give up his or her "self" in order to gain confidence and be part of the great power of digital thinking.

The mass human appears ready to hand over to artificial intelligence the right and responsibility to make decisions in as many areas as possible. Let digital friends make routes for people, manage enterprises and stock markets, diagnose diseases and give recommendations on their treatment, choose music to listen to, books and news to read, movies to watch, count votes in elections and conduct trials, making supposedly objective and impartial decisions. Humans will only possess and use all of this and will be great because of the greatness of the incredible computing power that will be at their disposal.

With the help of algorithms, people will learn to improve genetic parameters before birth, and afterwards – to improve the human body by implanting chips and taking empowering drugs. They will be able to instantly learn complex professions and acquire the necessary knowledge, for example, through augmented reality systems and neural networks integrated into glasses, mastering new languages or learning to fly a helicopter. However, at the same time, they themselves, i.e., their ego, will be minimized as much as possible. On the one hand, they will become consumers, on the other hand, they will become slaves because a slave is only a tool serving the subject of thinking and decision-making. Slaves themselves do not think and do not make decisions.

Digital totalitarianism in the first quarter of the 21st century is no longer an anti-utopia but a new reality, the space of existence of which is steadily expanding, threatening to engulf the entire human civilization. Totalitarianism (Latin *totalis* – all, whole, complete ← *totalitas* – wholeness, completeness) is a political regime that implies absolute (total) control of the state over all aspects of public and private life. The ubiquitous introduction of gadgets and artificial intelligence algorithms is doing a job of providing control tools better than any acting police force ever had.

Digital totalitarianism is much more dreadful than all previously existing systems of this kind because the subject of power and control in it is impersonal. Instead of a human being (a politician, a policeman or a neighbor in a communal apartment), an artificial intelligence, allegedly neutral and objective, performs the functions of control and makes

a number of decisions on encouragement or punishment. The average person cannot detect any evil intentions in its actions, which means that he or she can only accept what happens as a matter of course, as some natural forces, which, however, are not such.

The pessimistic scenario does not necessarily imply the revolt of machines and the physical destruction of people by them. It is likely that people will be eliminated in another way – mentally. They will simply cease to be thinking beings, delegating this quality to machines, and thus cease to exist as a species. This will be the end of the history of the rational human and beginning of the history of a digitized human, a bio-digital convergent.

24.5. Digitized Human

A digitized human is a potentially new species of living beings, a species of the genus *Homo* from the hominid family of primates. Under certain circumstances, they will be able to have a special physiological structure as well as appearance and behavior. Their main distinguishing feature is the introduction of various kinds of chemical preparations and electronic devices into the organism; the mediation of most of the mental processes by artificial intelligence algorithms integrated into the global informational network. In fact, the residents of technologically developed countries by the end of the first quarter of the 21st century already have many signs of a digitized human, the emergence of which is due to the increasing role of gadgets as well as the information received and processed with their help. A decisive step in the context of the assumed evolutionary leap should be the unification of biological and digital technologies into a single system for regulating the human condition and behavior. At the time of writing this text, humans have already come close to this in terms of the technical feasibility of such a system [38]. If it is formed, the probability of global digital totalitarianism will increase by orders of magnitude.

In order to see more clearly the trend of replacing human beings by computers in the field of intellectual activity, let us cite statistical information [42], which reports that during the 20th century the level of intelligence on average has increased significantly. Such a phenomenon is called the Flynn effect, a statistical phenomenon that is expressed in the gradual increase of intelligence quotient (IQ) indicators over the years, both in individual countries and in the whole world. This process seems paradoxical: the growth was observed within decades, therefore, it is difficult to explain it by evolutionary and genetic factors as a literal "smartening" of the human race.

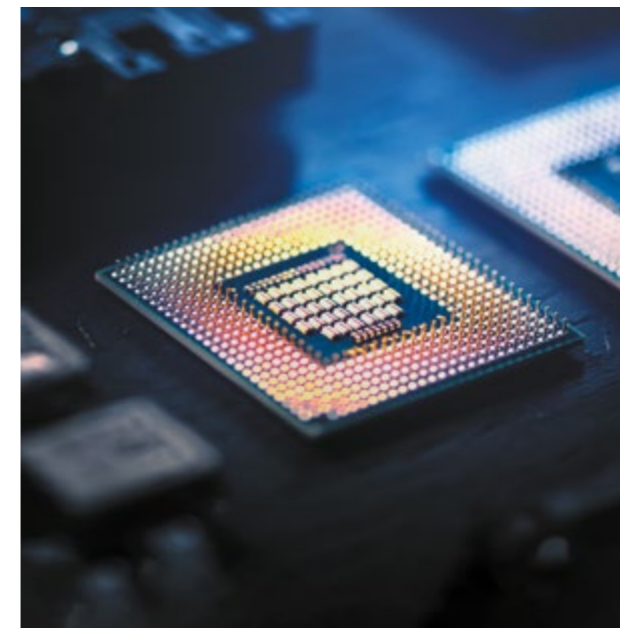

James Flynn showed [42] that from 1934 to 1978 the average IQ of US residents has increased by 15 points – about three points for each decade. Similar studies in other countries have yielded similar results. Thus, a New Zealand psychologist described a 20-point increase in the IQ of Dutch conscripts from 1952 to 1982. However, experiments conducted after 2000 showed a decline in the Flynn effect: IQ growth slows down, stops or is even replaced by a decline. In 2004, data on the IQ of Norwegian conscripts showed that the growth stopped after the mid-1990s and was replaced by a decline. Studies done in 2005 and 2008 found that the IQ test scores of Danish conscripts increased from 1959 to 1979 by three points per decade; during 1979–1989 they increased by only two points; during 1989–1998 they increased by 1.5 points; during 1998–2004 they decreased by the same 1.5 points. The situation was worsening thereafter. It is important that the turning point, when, after a long period of growth, people's intellectual abilities went into decline, chronologically coincides exactly with the beginning of computerization of society. Natural thinking in the presence of an alternative (replacement) turns out to be simply redundant.

Civilizational development reaches its culmination, acquiring the possibility of replacing not only the natural environment surrounding humans but also the individuals themselves in their natural dimension. If we take into account that, thanks to this, humankind gets at its disposal new unprecedented computational capabilities and a digitized human may seem superhuman to some, this situation is sometimes assessed as progressive. Some believe [38] that it is a good thing to transfer the function and the right to make key decisions to a sufficiently developed artificial intelligence. However, before agreeing with such statements, it is necessary to figure out whether artificial intelligence is capable of fulfilling the role which is held in store for it and which it is already assuming.

24.6. Fundamental Limitations of Artificial Intelligence

People think that an automated car control system is an intelligent system and, moreover, they are sure that an automated car is controlled by artificial intelligence. Is this really the case? Is a house in which you can open a window with the help of a smartphone really a smart house, even though it is uncomfortable and sometimes even dangerous for your health to live in it? Can we call a place where millions of people live and work a smart city, where “smart” “green” electric cars kill hundreds of residents, including children,

on the streets every year, just as environmentally dirty cars equipped with internal combustion engines killed them in car accidents before? The soil under electric cars is also “rolled up” in asphalt, in them as well as in ordinary cars one should stand in traffic jams for hours and breathe carcinogenic fumes from sun-heated asphalt, wear products of tires and roadbed.

On what basis is electric energy considered the safest and most environmentally friendly, including that used for the electric cars? In fact, it is safe only at the point of its consumption, not at the point of its production:

- environmental disasters in Chernobyl and Fukushima are the result of industrial production of electrical energy derived from the atom;
- acid rains, global warming and destruction of the planet's protective ozone layer are by-products of thermal power plants;
- flooded thousands of square kilometers of fields and forests are the result of the construction of hydroelectric dams, which not only block fish migration routes but also grind all living things with their turbines, releasing downstream nutrient broth for the reproduction of pathogenic microflora;
- windmills that kill millions of birds [43] because they cannot see the rotating turbine blades. In addition, the blades, with their capability of reaching the speed of sound, create powerful noise and vibrations (from low-frequency to high-frequency, which kill earthworms, the source of soil fertility) and make life unbearable for people even a few kilometers away due to these allegedly green power plants;
- buzzing wires of high-voltage power lines, under which it is impossible to grow anything or graze cattle, and it is dangerous for health to live and work nearby because of the powerful alternating electromagnetic field [44].

One can argue about how complex a mechanism an electric car is and how difficult it is to control it with six simple actions: “accelerator”, “brake”, “forward”, “reverse”, “left”, “right”. However, since the very notion of intelligence came from a *Homo sapiens* – the peak of perfection of living matter, it is necessary to find the essence of this term not in mathematics and physics, not in philosophy and business but in the concept of “Life”, i.e., in living organisms.

The basic structural unit of any living organism is the DNA molecule, in which all its genetic information is recorded. This molecule has hundreds of billions of parts – atoms of various chemical elements [45], embedded in well-defined places in a molecular-spatial structure of the highest complexity.

An electric car, on the other hand, has only a few thousand parts. So, the DNA molecule is unimaginably complex from the engineering point of view – it is millions of times more complex than an electric car. DNA is even more complex than all the innovative technologies created by thousands of generations of people of our civilization (about 100 bln people who lived on the planet) over the long human history (more than a million years, starting from the invention of the first fire): bolts and nuts, bridges and skyscrapers, internal combustion engines and turbines, rockets and airplanes, cars and railroads, computers and smartphones as well as thousands and thousands of other engineering technologies.

The DNA molecule is more complex than the entire nonliving part of our vast Universe (i.e., without planet Earth), which stretches for tens of billions of light years, consisting of trillions of trillions of planets, stars, galaxies and galaxy clusters. After all, the Universe, which, according to one of the theories, emerged from the singularity as a result of the Big Bang, was formed during billions of years (in the process of expansion of energy and matter in three-dimensional Space) randomly under the influence of the physical laws that emerged in the singularity, in particular gravity, which people then called the laws of physics – they are the “genes” that created our Universe. Such dead (i.e., nonliving) physical “genes” can be described by much simpler mathematical formulas than the genes of the DNA molecule that give life. The formation of planets, stars, galaxies and their clusters occurred mainly under the influence of only one of the features of matter – gravity inherent in it [46]. This main “gene” of the Universe growth and development has fulfilled its important mission: it has gathered hydrogen into stars and ignited them, including the Sun; it has created black holes, which formed galaxies around them; it has gathered rocks and stardust into planets, including Earth (keeping the atmosphere, otherwise our planet would fly away into space), on which then life was born, perhaps, the only one in the vast Universe. The probability of its random occurrence is too infinitely small.

Industry is formed of its industrial “bricks”: units, mechanisms, equipment, various technological processes and materials, from which plants, power plants, roads and other industrial systems of countries, regions and the Earth's technogenic civilization as a whole are then built. At the same time, all its industrial power (the terrestrial technosphere) by its intellectual potential as well as the intellectual potential of all people who lived on Earth and have been

creating this technosphere for thousands of generations, as justified above, is very much inferior to the intellect of the Creator, who invented such a “simple brick” of any living organism (not life and biosphere as a whole) as a DNA molecule.

Each living cell of any living organism is millions of times more complex than DNA, and there are about 40 tln of them, for example, in the adult human body alone [47]. Cells have their own roads, bridges, power stations, plants, factories, slipways, machines, bioreactors – about 50,000 complex biochemical (not simple chemical) reactions occur there at a time! All tissues, organs and systems of our body are made of these cells, which are of about 230 types: 850 muscles, 208 bones, 230 joints, 10 major systems, 78 organs, dozens of glands, billions of endocrine cells producing thousands of completely different secretions, hormones and biologically active organic substances that regulate the most complex biochemical reactions – metabolism in cells and organs.

In addition, the human body is endowed with the most complex internal transport system – more than 100 bln blood vessels alone with a total length of about 100,000 km with 25 tln “vehicles” [48], i.e., blood erythrocytes (if all erythrocytes are arranged in one line, close to each other, it will stretch for almost 200,000 km), and also has its own informational network – nerve fibers with a total length of about 150,000 km. At the same time, there is a huge number of all kinds of connections (for energy, information and products) both inside the organism and with the outside world, the exact number of which is unrealistic to calculate: it is likely to be more than a googol, and this number is unimaginably large.

By its engineering complexity, and the Creator was certainly an engineer (but in no way a banker, politician, economist, philosopher, priest or oligarch), the human organism is myriads of times more complex than everything that our engineering civilization has created in the history of its existence, and it is impossible to give a more precise value of this complexity than the abstract “myriads”.

Let us imagine a human lying in a coma. His body is functioning normally, his organs and systems are working properly, and the work of this hypercomplex creation is controlled by his own brain without anyone else's help. Such a person does not have only consciousness. Can it be said that in such a state he possesses intelligence? Of course not.

People began to use the term “artificial intelligence” to refer to primitive systems for controlling technological processes, such as automobile, with the help of primitive

machines – hardware computers, which are, in fact, fast calculators. Such “intelligence” has no consciousness, spirituality, worldview, morality, ethics, morals, culture and goal-setting. It is obvious that the ability to quickly calculate and manage any processes, both technological and vital, is not included in the concepts of “mind” and “intelligence”.

The main reason for the emergence of ideas that the digit should lead the individual, society and humanity as a whole is the desire of the “global elite” to obtain super profits with uncontrolled and irresponsible management of humanity, reduced to the level of digital biorobot-convergent, where each digitized humanoid creature will be just a faceless ant or a worker bee in a swarm.

From the engineering point of view, the attempt to create a “brave new world” of inclusive capitalism is no better than the idea of creating a world in which, for example, the flight of a primitive Boeing airplane will be controlled by an incredibly complex virus, such as COVID-19. The fact that the simplest virus made up by the Creator is incredibly more complicated than any most complex human-made machine, which is described in detail above, is evidenced at least by the fact that human can design airplanes, make them from scratch and then improve them, including inventing an autopilot to make them fly even better. But the virus – no, human is not able to design it from scratch, from atom to atom, he can only somehow modify a natural virus, completely unaware of the long-term consequences of such an engineering transformation.

Simple systems should be managed by more complex ones, and not vice versa, as it is planned to do in the virtual universe being created in the 21st century. Moreover, the managing system should be more complex than the controlled one by many orders of magnitude. For example, a mosquito, which is millions of times more complex than a virus or even a monkey, which is even more complex, will not be able to control an airplane. The “successes” of so-called artificial intelligence (all of them imaginary, not real) are not due to the fact that it is supposedly very clever, but due to the fact that it is generated and accompanied by a creator – intellectual person, engineer. And not just one but a society, and not just the society of some single African tribe but of the entire Earth’s technocratic (i.e., industrial) civilization.

It was civilization that gave everyone the main components of their personal intelligence – awareness, spirituality, morality, culture, goal-setting, the baggage of knowledge, including scientific knowledge, formed during thousands and thousands of generations of development of *Homo*

sapiens and Earth’s industry as a whole, which, in fact, made it possible to develop a fast computing digital machine. This means, a stillborn (because it is not alive), unintelligent and spiritless child of technological progress called artificial intelligence should in no way guide its creator – a human with real live intelligence. Otherwise, it will be like in the story with an airplane controlled by a virus, a mosquito or a monkey: after taking off, such an “intelligent” device will certainly crash. At least for the simple reason that even after learning to control the technology, the mosquito will not learn to use it expediently, for example, to refill it with fuel, which still has to be produced somewhere and then delivered to the airplane.

The essence of civilization, which is to establish an order parallel or alternative to the natural order, in the ultimate perspective can be realized in only three scenarios.

The first is the global oppression of all living things and their displacement (replacement) by artificial ones.

The second is the rejection of the civilizational (technological) path of development and a return to savagery, accompanied by the triumph of nature.

The third is the establishment of a balance between nature (animate and inanimate) and artificial forms of organization of matter and thought.

The latter scenario is possible only with a strict distinction between the technosphere and the biosphere, including segmentation of areas of application of digital and natural thinking. It is necessary that virtual reality technologies serve the actual (real) world, and not vice versa, as they are now trying to position it as some kind of universal benefit from inclusive capitalism.

Engineering in projects related to artificial intelligence reaches its apotheosis and loses touch with reality. On the one hand, in the form of industry, it destroys it by polluting it with waste. On the other hand, it replaces reality with refined artificial constructs. Engineering is at war with nature, although it does not set itself such goals. It does not set goals at all but turns out to be only a tool for achieving them. The goals themselves are dictated by power, embodied in capital or systems of state repression. However, only engineering can and must become a goal-setting principle. Only engineering can save civilization and the world.

It is necessary to reject the continuation of existence in the format of technocratic civilization, which replaces the living with the dead. Civilization should become of an engineering nature, so that not technology but the living and the main thing in human – Mind – rules the world.

3. Axiology of Engineering

3.1. Why Only Engineers Can Save the World

Only engineers can save the world. They are the only ones who are able to lead humankind away from the false path of the so-called “elites” of the 21st century, which grew out of the same impostor and self-proclaimed “elites” of the previous centuries. Why false? Because they are contrary to life and nature.

The idea that the future of civilization rests only in a return to a state similar to primitiveness is unnatural and monstrous. Is it possible to presume that the best thing for humanity would be an artificial population decline, the replacement of humans with robots and artificial intelligence and the total control of conscious and physical life using digital and biochemical technologies? The above implies the utmost removal, a departure from all organic and natural to all artificial and manufactured. And if nature is the criterion of good (it is so, and I will tell you why) then the proposed course of action will lead to an absolute evil – satanism in its purest form.

Life and nature are the criteria of truth, goodness and beauty because they rise above everything and have no more significant definitions and certainties than those inherent in them. Of all the living things that are conceivable to us, it is humankind that brings something else into the world apart from nature. In Christianity, this is called free will. And this ability is not only to follow the laws of nature but also to use them for one’s own needs and even to oppose them, which is the cause of human’s evil, falsehood and ugliness. So, for example, killing a living creature is not itself evil if done by nature’s laws to obtain food. But murder committed by human for profit, power or perverse pleasure is malicious, false and ugly. In science, on the other hand, something corresponding to the natural structure of the object under study will be the only true statement. In art, it is beautiful only if it reveals the nature of the thing portrayed. Finally, in engineering, the most efficient device is the one that makes the best use of natural energy and produces minor damage to nature.

If life and nature are absolute reference points for human, they must be the same for all humanity and civilization. From this perspective, we, like all life, must strive to grow, multiply numerically, develop physically and spiritually, occupy new territories, and humanely – without disturbing or destroying them. It is necessary to increase production, expand the industry, extract and process more and more, move faster and faster. The main thing here, in the industrial vector of development of our multibillion civilization,

is not to clinch with the Live Nature, our home inhabited by life about 4 bln years ago, the Earth’s biosphere. Under the accepted thesis of nature as the criterion of truth, only this path is valid. But is it possible? Or have we exceeded the capacity of our planet? Or is it true that the only way for humans to follow nature is to turn against it? Perhaps to commit suicide? Or to destroy everything in creation? To limit and to emasculate ourselves? Does it turn out that humans generally represent some misunderstanding, a ridiculous mistake of nature, a dead-end branch of evolution?

Engineering has become a systemic element for modern civilization. The world is defined and controlled by technology invented and maintained by humans. This technology is killing all living things, including those who serve it. Who can make a difference? Only those who know how to manage, design and optimize technology.

Humanity cannot give up on industry. As Voltaire said, you can move backwards to nature, but then you will have to get on all fours. If we abandon the technogenic path of development, most of humanity will die out. Therefore, if we cannot give up industry and at the same time want to maintain suitable conditions for our survival, we must change the industry. This can only be done by the engineers who have created the industrial leviathan.

Using engineering means to eliminate the problems created by engineering, similar to the famous “Physician, heal thyself” – this is the existential challenge of the 21st century. Priorities must be set. Of all the values, the highest one should be a reasonable arrangement of the environment. Because only this value in the 21st century can provide the conditions of preservation and growth for humanity.

Of all the strata and layers of society capable of claiming a decisive voice, only engineers can do so by right and circumstance. Politicians, regardless of their views and party affiliation, will always be concerned only with power. To do so, they must inevitably share everything – space, resources and influence on people’s minds. The more you have, the stronger your power, but you can never have everything until there is another power-seeker off the leash. If you are a financier, you are concerned about numbers and will soon pull away from reality. Precepting the world through financial relations is monstrous and murderous in its essence. Human lives and great nature turn into flows of values and quotations. The banker’s goal is profit. Nothing real is taken into account, and everything (even the planet) can be sacrificed for a good amount. How much is the planet?! Religion has lost the consolidating power it once possessed. Priests and clerics offer to seek salvation in another world,

while this world, torn apart by politicians and financiers, is dying. Art is ephemeral, science is indifferent. Only engineers remain – servants of people, who, in order to save the latter, must become masters themselves.

3.2. Why Engineers Do Not Rule the World

The revolutionary engineering spirit changes the entire epochs when the rapid development of transportation, fuel and energy, metallurgy, machine-building, chemical, micro-electronic, construction, agricultural and other industries begins. As for the inventors themselves, the managerial and commercial dimension is inherent in them to some extent, but in the realm of exact sciences they manifest themselves best.

Engineers seem to live in a world of their own, unconnected to the rest of the human Universe. They are driven by ideas. A few enthusiasts, faithful to the dream, unite around the idea. They occupy the simplest production facilities and develop into a full cycle of manufacturing of various mechanisms, multikilometer conveyors, a continuous assembly line of cars in 10 s, combat aircraft in 1 h or corporations that have actual impact on geopolitics. Engineers are often at the origin of these organizations. It happens, being initially low-profile and underprivileged, they are at the origins of the entire industries. And then, almost always, engineers withdraw into the shadows.

The overall management of the sprawling technogenic giants is being handed over from the founding families to those who are more legally and commercially savvy and better informed about the global balance of power and political conjunctures. The engineering thought, stumbling over mass production, endless profit maximization and the ever-increasing drive for gain, returns to itself. It is from this secluded, rigorous intellectual world that engineers bring their fundamentally different and stunning ideas into the reality of the average person. First the ideas are met with rejection, then with a cautious acceptance and, finally, with universal admiration.

From Nikola Tesla's diaries: "If I only think about it, I see the whole picture. I experienced it for the first time in 1882 in Budapest. During a walk in the park I suddenly showed myself the scheme of the engine working on alternating current. Even before I understood what was happening, I began to draw the diagram quickly with a cane on the sand because until that day it was not my habit to always carry notebooks and pencil" [49].

The government has always sought to put these unique people – engineers, inventors, scientists – at its service

in order to ensure advantages and more favorable positions in the competitive race for supremacy among other powers. Not really going into the essence of research and depth of engineering studies, those in power were mainly interested in the practical significance of discoveries and inventions. And there is no contradiction here as one cannot serve two masters: either an engineer is absorbed in discovery and cognition of regularities existing in nature, creation of new forms of things and processes, construction of devices that can help in more perfect exploration of the world, or he strives to accumulate power, participates in the struggle for leadership and domination, strives to consolidate power, protects it and serves its achievement.

Igor Kurchatov, the originator of the Soviet atomic project, headed a special laboratory in 1943 under a secret order from Joseph Stalin "On Organization of Work on Uranium". Colleagues spoke of the scientist as a talented and vigorous organizer of engineering work, who at the same time was independently responsible for solving complex scientific problems. Associates of the legendary physicist were officials and managers who were responsible for the urgent execution of industrial orders, construction of enterprises, development of mining and processing of uranium ores and coordination of various endeavors. Kurchatov himself was on the cutting edge of solving the problem, which completely absorbed him, so sometimes he could be on duty in the reactor hall, risking a lethal dose of radiation. This Soviet scientist was the passionate creator of the world's first atomic reactors and power plants. And it would be pointless to try to imagine him involved in an internal party struggle for power or agitating in favor of universal equality, freedom and fraternity, while subduing the undesirable and disobedient by waves of mass repression on the way to the establishment of a totalitarian society.

The government is always interested in using people of science and engineers to protect and strengthen its influence and power. Therefore, the power encourages or neutralizes such people depending on what it needs at a particular historical moment. For his exceptional services in solving the problem of atomic energy use, Kurchatov was awarded honorary titles, rewarded with 500,000 Soviet rubles and received a car as a gift.

Another example of the extreme interest of the government in engineering discoveries in rocket science took place immediately after the Great Patriotic War. At that time, US intelligence exported German scientists of Hitler's Germany to their country. The authorities in America were

not at all embarrassed that the father of the so-called American space program was a member of the Nazi Party, SS-Sturmbannführer Werner von Braun. He and other German scientists were given new biographies as part of Operation Paperclip, which made no mention of membership in the Nazi Party. This is how the US "laundered" the scientists it needed from Nazism and gave them the opportunity to live and work in peace for the good of America. It is known that forced labor of concentration camp inmates was used in the construction of rockets and many people died. They were outnumbered by those who suffered from the use of the rocket itself as a weapon. However, von Braun and other "useful" people were not prosecuted and did not end up at the Nuremberg trials. Thus, in the last century, the USSR became the power to build the first nuclear power plant, and the United States became the country to construct the first nuclear bomb...

In the 21st century, engineers continue to play a crucial role in the development of civilization. It is not only about supporting and utilizing everything created for the benefit of humankind but also about the unceasing development of new technologies. The status and remuneration of engineering competencies today vary depending on the specialization. According to the Bureau of Labor Statistics report in 2019, the average salary for engineers in the USA was 94,000 USD per year, with the highest paid engineers making over 150,000 USD per year. In Germany, which is one of the most recognized leaders in engineering and has a high salary level for engineers, it's an average of 65,000 USD per year. In China, engineering is developing rapidly. Many foreign companies invest and develop their projects with a focus on China, which leads to a high demand for specialists in various fields. The Hays Asia Salary Guide report says that engineers in China can earn more than 30,000 USD per year. In India it's about 10,000 USD per year. Despite this disparity and, in some cases, impressive sums, the pay available to engineers is not comparable to that of stock speculators, arms and resource dealers, politicians and directors of multinational companies.

We see engineers being used as support staff to create and arrange the material world for the global purposes of the government or to work for private capital. Then why don't engineers run the world? After all, the world is created, maintained and developed by them. With the technological advancement, the need for and dependence on technically literate people around the world is only increasing. Instead, we observe the processes of engineers' enslavement, their distribution into industry segments and farms

for the purpose of exploitation. It turns out that the inspirers and inventors of the world have to fight for their rights, defend acceptable working conditions and achieve the simplest and necessary for life benefits, while the beneficiaries are the holders of power and capital. It is they who decide the distribution of benefits, establish convenient laws and exceptions and are much more concerned only with their financial interests.

No matter how unjust the world may be, and no matter how many waves of indignation of the oppressed against their oppressors may rise from time to time, the world still ends up with a pattern in which, under various, more or less beautiful wrappings, the absolute majority is exploited by the minority and legalized methods of theft are practiced. In the 19th century, the proletariat of the USA and European countries made every effort to reduce the working day to 8 h. In some industries, those working in difficult conditions, for example underground, were able to get at least a relative amount of rest. However, in disputes over the possibility of regulating the length of the working day, judicial practice was mainly on the side of businessmen. Over the course of a century, it took many mass worker protests to change this situation. At all times, the beneficiaries have been reluctant to make concessions and certainly never willing to share power. Unfortunately, history knows of no examples of a complete voluntary transfer of power to engineers.

We can conclude that engineering, like any creative thought, is a self-sustaining passion. It is in itself so significant and fascinating that it can overshadow the rest of the world. And no matter what happens, no matter how low engineering labor is evaluated, nevertheless, being a vocation, it creates internal laws and meanings by which a creative person lives. In this respect, it is much more honest, stable and predictable than the world, in which a ruthless struggle for power has been going on for millennia. The latter is precisely the desire to rule the world, and in this race from ancient times people of various professions have participated, who were not always the best but always had great ambitions. The qualities necessary for this struggle can be combined with engineering genius, but sooner or later everyone has to choose one thing and give an answer to the question: "Who were you: an engineer, a businessman or a politician?" Because one passion will always be overcome by another, stronger and more exciting one. Unfortunately, engineering as a passion (as well as the struggle for power) is itself devoid of moral implications and is therefore simply an act of will.

3.3. Government Against Engineers

Engineers are often unwanted. There are reports that at the time of Russian tsar Ivan the Terrible, there was a human who invented wings. A peasant named Nikita built a flying machine out of wood and leather. He climbed the bell tower and flew over the fortress called Alexander Sloboda. The flights were reported to the tsar, who ordered: "Man is no bird, he has no wings. But if he gives himself wooden wings – he acts against nature... For this friendship with the evil, cut off the inventor's head... And this invention, as if created with the devil's help, after the Divine Liturgy shall burn" [50]. However, when the same ruler's engineers laid a charge under the walls of an enemy citadel or armed an elite army of shooters with rifles and cannons to kill, it was considered normal, not abominable.

Until the 18th century, the profession of engineer correlated exclusively with military equipment such as weapons, defensive and siege structures. The government never had much need to optimize peaceful life with technology. The fact that the scientific and technological revolution once took place is the result of the engineers' revolt. No one called on them, no one invited them to change the world. They did it out of their own initiative, against all obstacles and risks to their lives.

In many cases, the government simply does not hear engineers. Even the founder of genetic engineering, Gregor Mendel, did not find a response to his invention. His report, which described the key laws for the future Green Revolution, aroused neither interest nor discussion. His experiments in plant hybridization and mouse crossbreeding went unnoticed. He ended up spending his old age as a beekeeper. In the 1860s, people were interested in steam engines, not peas. The constant famine in Europe and its colonies, which was causing many deaths, was of no concern to anyone. Money was made on other things. It was only half a century later, when the inertia of the industrial revolution went down and the world approached the global crisis of World War I, that Mendel's discoveries were given the green light. However, even then it was not without incidents.

In the 1930s, when genetics was developing all over the world, the Soviet authorities decided to overtake the whole world and, like gamblers, bet everything on a technology that, according to the authors' unproven assurances, made it possible to increase yields fivefold in the shortest possible time, without years of work on breeding new varieties. Engineers who dared to go against the party line were repressed. Among them was the outstanding genetic engineer Nikolai Vavilov.

In the case of Vavilov, the government appeared to have good intentions. In reality they were concerned with their own power and enrichment. By this time, agricultural products should have become one of the main export items. But this could not be achieved, although it was very much desired. To judge how strong this desire was, you can look at the experience of 1930, when suddenly the volume of grain sales abroad exceeded five times the figure of the previous 1929. It turned out that this product was simply confiscated from the peasants, which was one of the causes of mass famine, including in Ukraine in 1932–1933. The authorities needed a quick result, no matter what the cost, including human lives.

Ultimately, the political pressure on agricultural engineers in the 1930s cost the USSR biotechnology lagged far behind Europe. The government gained excessive control over engineering, essentially officially reducing all work on the technical improvement of the economy to the activities of state institutions. As soon as the power became absolute, it demonstrated its primitive animal nature, chasing, as they say in Russia, the short ruble.

If power is distributed through the capitalist system, engineering is counteracted through the subjects of economic relations, not directly, as in the example of the USSR. At different times, professional estates, large landowners or owners of industries have stood in the way of progress.

An important invention (along with the steam engine), which marked the beginning of the industrial revolution, was a newly designed mechanical spinning device. It was created by the Englishman James Hargreaves in 1765 and was called the "Spinning Jenny", after either his wife or one of his daughters. The compact and relatively affordable machine was six times more productive than available alternatives. At the same time, it required one person to run the "Jenny". This meant that at least five spinners were out of a job. The innovation caused a great deal of resentment. Hargreaves had only managed to build and sell a handful of machines when his house and its equipment were burned to the ground in an armed raid. This case is probably the first in history to show how competition encouraged going to war against new technology.

When George Stephenson made his first trials, he had to hire huge boxers to walk in front of the locomotive and fend off farmers armed with pitchforks who were intent on tearing the "fire-breathing beast" to pieces. When the first commercial interurban line was built between Stockton and Darlington, landowners began to resist the innovation – their reaction was immediate. When the project was first considered in Parliament, Lord Darlington objected, not liking the fact that the route would pass through his lands,

where the aristocrat liked to hunt foxes. After some debate and the hunter's use of high-level connections, the construction proposal was rejected. The authors of the project had to modify it to bypass Darlington's lands, and the railroad was built. For nearly another decade, however, the new transportation systems would not be embraced by the owners of the land over which the rails were to be laid. Protesters drafted collective letters to authorities, collected signatures, etc. They argued, for example, that because of the noise and smoke, cows would stop giving milk, trees would stop bearing fruit, chickens would stop laying eggs, houses along the roads would burn down and inns would be ruined. As can be seen, the arguments were purely economic.

In addition to landowners, shipping and canal companies were also dissatisfied. On the Manchester – Liverpool route, where Stephenson laid the first commercially viable railroad in history, the canals had long been the main thoroughfares. Naturally, road trusts and stagecoach owners also became agitated. Accordingly, problems arose from the very beginning of construction. Surveyors were attacked with stones, pitchforks and other weapons. Real battles broke out, during

which the attackers tried to take the theodolites as spoils of war. Again (this time to protect the equipment) Stephenson had to enlist the help of a professional boxer, a local champion. Sometimes the surveyors were forced to work exclusively at night, while the men of one of the co-owners of the canals named Bradshaw, who was also a landowner in the area of interest to the railroaders, randomly fired guns in different directions. In addition, Bradshaw distributed leaflets depicting the horrors of laying the rails. But in spite of everything, the job was done [51].

Very soon the British were convinced of the efficiency of the new technology. The shareholders of the road received up to 10 % dividends annually. Landowners gradually realized the inevitability of progress and the possibility of receiving serious compensation for the use of their property. The amount could be the greater, the less resistance from their side, and consequently, the lower the costs of the railroad company. Since the most significant compensation was paid to those whose houses stood on the track, there were cases of hastily erecting something resembling a dwelling there.

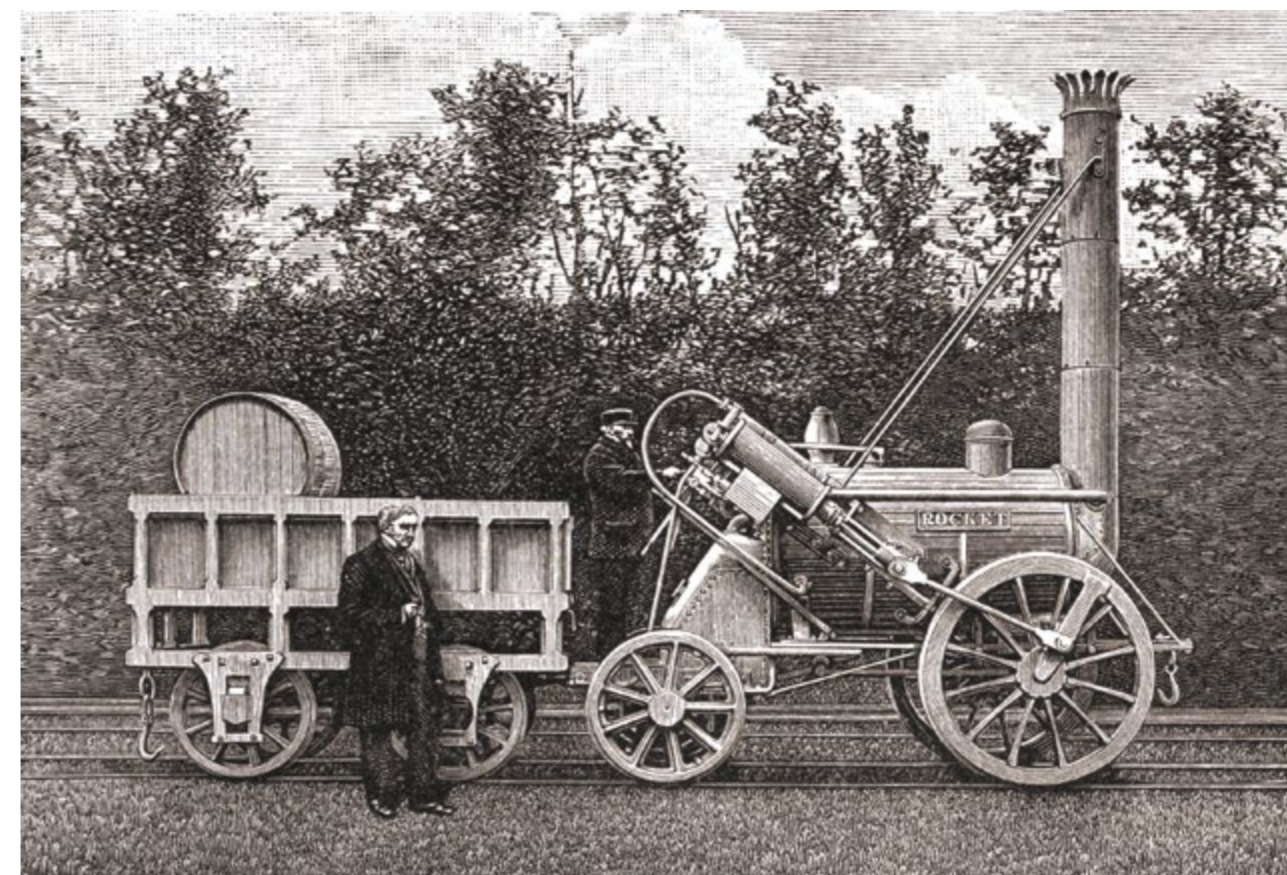

Not only landowners but also doctors were against the innovations. In 1837, the Bavarian Royal Medical Council gave the following conclusion: "The construction of railroads would be detrimental to public health. It is obvious that the rapid movement (at a speed of 41 km/h) must cause brain disease, a kind of raving insanity, in the passengers. Since it is also obvious that there will be people who are not frightened by this terrible danger, the state is obliged to protect at least the spectators, for the sight of a fast-moving car can cause a similar disease in them as well" [52]. In the same vein, French journalists described the consequences of travel, claiming that a human who got off the train, "saturated with speed", would continue to run until he hits some obstacle and his head would split open like a watermelon.

With the resistance that the railroaders faced, every slightest blunder of the engineers and builders went in favor of the opposition. Accidents and disasters were constantly recorded. During the commissioning of the same first line from Manchester to Liverpool, there was a tragedy. When the locomotive "Rocket" built by Stephenson stopped for refueling with water, MP William Huskisson got off the train to look around. The train moved off. The parliamentarian panicked and found himself under the wheels. Naturally, this was seen as a bad omen. Over the next few years, people unaccustomed to the new threat continued to die on crossings and overpasses, adding fuel to the fire of public outrage. The Household Narrative, an English newspaper, even had a special section devoted to accidents involving steam locomotives. However, the convenience and speed of transportation that the new technology provided to people proved to be a more powerful argument than all the losses incurred by the ruling class of capitalists. The railroad spread its network and soon its owners became the bosses who did not want to give up the throne to anyone. And just like their predecessors, they were ready to do anything, right up to a murder.

The first patent for an internal combustion engine was issued to Frenchman Philippe Lebon in 1801. The engine was powered by luminous gas produced by burning coal in an airless space. The inventor did not have time to build a prototype. The drawings were ready, and work had already begun, but in 1804 Lebon was killed under mysterious circumstances. Unknown people attacked him on the way to Napoleon's coronation ceremony and stabbed him 10 times. Behind this crime contemporaries saw traces of railroaders. Nevertheless, the advent of automobiles was inevitable. And just as in the case of the railroad, the onset of this inevitability

was associated with great resistance of power and business embodied in the representatives of the ruling classes.

Automakers and their shareholders had to overcome the lobby of horse and stagecoach owners as well as manufacturers and sellers of wagons, harnesses, fodder and others. For example, an English poster from 1908 denouncing "reckless motorists" who "kill your children", dogs and chickens, "fill your house with dust" and "spoil your clothes", causing the loss of 100,000 jobs in industries related to carriage transportation [53]. Neither these nor all other objections and protests could stop the spread of cars. By 1929, thanks to Henry Ford and his car, the Model T, available to the middle class, almost every family in the United States owned a newfangled vehicle. There were 20 cars for every 100 people. Gradually, other countries were doing the same. In 2020, there were almost 1.5 bln of these horseless carriages on the planet.

All these cases show how engineers paved the way for their peaceful inventions through misunderstanding and persecution. Only military discoveries have always been successful. With the support of the authorities, engineers came up with ever more sophisticated instruments of murder and plunder. Engineers served the world by facilitating crime. Engineers changed the world for the better through rebellion against the system. The system then adjusted to them by changing. In the reality of the 21st century, a new rebellion must happen. An uprising of engineers.

3.4. Discovering the Power of Technology

As you can see, engineering and technology in the past occupied a modest place on the stage of civilization. History was made and dynasties were created, while weapons and tools of labor are only tools for achieving such goals. They have no effect on anything in themselves. They can be treated neutrally or even neglected. The situation was slowly changing. Machines were taking over the world and beginning to dictate the rules. But the inertia in thinking about them persisted for a long time.

The neutrality of technology was taken for granted in the 20th century. The underestimation of technology led to the largest wars, in which technology appeared as a global meat grinder that crushed tens of millions of human bodies. But there were those who understood, those who foresaw the catastrophe, and those who realized its causes when it was too late to change anything. Martin Heidegger wrote: "...We are delivered over to it [technology] in the worst possible way when we regard it as something neutral; for this conception of it, to which today we particularly like to do homage, makes us utterly blind to the essence of technology.

...The revealing that rules in modern technology is a challenging, which puts to nature the unreasonable demand that it supply energy that can be extracted and stored as such. But does this not hold true for the old windmill as well? No. Its sails do indeed turn in the wind; they are left entirely to the wind's blowing. But the windmill does not unlock energy from the air currents in order to store it" [54].

According to Heidegger, technology, having become the social anchoring element, determines entirely how the humans view the world. And as long as it is perceived only instrumentally, our world has no chance of self-preservation. Technology in such a context grinds up the natural and mental masses in order to ensure its existence. It becomes an end in itself. Technology thus gives dimension to everything. And makes everything neutral and lifeless. These are the consequences of the moral neutrality of technology and engineering.

Others have also spoken of the importance of giving technology a moral dimension. For example, Nikolai Berdyaev noted that "the development of practical science was for him [Karl Marx] merely a subordinate function of social processes.

Our moral attitude towards technical achievements presents an important problem, worked out but little as yet. It has a significance for the world as a whole. The ethics of creativeness must admit that the progress of practical science has positive value and is a manifestation of human's free spirit and of his creative vocation in the world. But at the same time it must clearly recognize that such progress brings with it the greatest danger of new slavery and degradation for the human spirit. We must be keenly sensitive to this and rise above a neutral attitude to scientific progress. It is wrong and unspiritual to oppose to the new world discovered by science the old primeval "earth" and "nature" to which human ought to remain subordinated. The "earth" is a religious symbol but it may be understood materialistically. And it must be recognized that science, destroying as it does many illusions born of weakness and dependence, may help us to overcome religious materialism and attain greater spirituality, though, on the other hand, it threatens to materialize life through and through. The achievements of practical science put the human spirit to the test and bring out its essential qualities. The right attitude towards scientific progress inevitably presupposes a spiritual asceticism and control of the lust of life to which science is always ready to pander. Practical science has an eschatology of its own, opposed to the Christian, and its goal is to conquer the world and to organize life without God and apart from a spiritual regeneration of mankind" [55].

"One of the consequences of scientific progress is that everything which had appeared as neutral acquires a spiritual and religious significance. Technical achievements are morally neutral up to a point. When they reach a certain level they lose this neutral character and may turn into black magic if the human spirit does not subordinate them to a higher purpose. Scientific and technical progress may eventually lead to the destruction of the greater portion of mankind and even to a cosmic catastrophe. The moral and spiritual condition of man, who has acquired an unheard of power over nature, becomes of paramount importance. Nature was at first full of gods, then it was regarded as a dark power and finally, in modern times, it has been completely neutralized. But the progress of practical science confronts man with a new nature which can no longer be considered neutral" [55].

Both authors saw in technology not only a threat but also an opportunity to save the world. To do so, it must serve some kind of higher value, and not just supply products to the consumer society. By serving values, technology itself becomes a value, just as one who climbs a mountain becomes a summit for others. However, technology is the embodiment of engineering and the result of the engineer's labor. Therefore, it should not be a value and reference on its own but as engineering. In addition to the value dimension, engineering is given the function of a goal-setting principle. The coincidence of value, purpose and instrument is only possible in engineering. This is the basis of its power, which cannot and should not be interpreted as the power of technology, as traditional technocrats try to suggest. It should be the domination of the living human principle, embodying rationality and reason – engineerocracy, which includes both engineering, social and humanitarian components.

3.5. Essence of Engineering and Engineer

The monkey picked up a stick and became the human. The human attached a stone to the stick and became an engineer. The essence of a creature's transition from the animal state to the rational state is that something else appears between the action and the object in relation to which this action is performed. At first it is an object, then the images of objects, the language and, finally, abstract concepts. At some stage of development, the sequence begins to work in the opposite direction, from concepts to objects. Through the concepts, goals are set, which are particularized in the language of mathematics, in order to combine the objects in an expedient way and to influence the object by means of the resulting mechanism or device.

Engineering is a type of supreme creativity as a human activity to transform the material reality surrounding everyone. The goals of engineering are always clearly defined and focused on achieving a practically measurable result, and the means are limited by available experience, knowledge, the requirement to minimize resources and efforts while maximizing efficiency as well as the laws of the physical world around us, laid down by the Creator initially, at the time of the Creation of the Universe.

Here is an example from the era of primitive technology: a river prevents a group of people from freely crossing to the opposite bank, which people have concepts about. There is a forest there, which means there may be game. It can be caught and eaten. For the crossing, you need an object that can hold on to the water itself and support a passenger. Logs float well. It's uncomfortable on one. Therefore, it is better to connect several of them with something like a rope and get something like a raft. In such concepts a person defines a goal and a possible algorithm of its achievement. Then he starts to count by using the language of primitive mathematics. What number of logs will be optimal? How many stems will it take to weave the ropes? What is the approximate length of the ropes? Having calculated, engineer begins to act to create the device necessary to accomplish the goal. Based on concepts and calculations, he combines preexisting objects in ways they have never been combined before.

Reflecting on technology, Oswald Spengler wrote: "...Soul strides forward in an ever-increasing alienation from all Nature. The weapons of the beasts of prey are natural, but the armed fist of man with its artificially made, thought-out, and selected weapon is not. Here begins "Art" as a counter-concept to "Nature". Every technical process of man is an art and is always so described – so, for instance, archery and equitation, the art of war, the arts of building and government, of sacrificing and prophesying, of painting and versification, of scientific experiment. Every work of man is artificial, unnatural, from the lighting of a fire to the achievements that are specifically designated as "artistic" in the high Cultures. The privilege of creation has been wrested from Nature. "Free will" itself is an act of rebellion and nothing less. Creative man has stepped outside the bounds of Nature, and with every fresh creation he departs further and further from her, becomes more and more her enemy. That is his "world-history", the history of a steadily increasing, fateful rift between man's world and the Universe – the history of a rebel that grows up to raise his hand against his mother" [56].

Engineering is the highest form of creativity, and its result is the most intellectually rich form of art. Just as an artist takes paints and draws a picture, and a writer composes a novel from words, an engineer, putting together constructive and technological elements created by previous engineering and science, gets a result that is not equal to the sum of these parts. There is always a synergy here. Taken together, such parts become an engineering work of art with a new quality. In our example, something fundamentally different has been created from logs and stems – a simple floating vehicle. The difference between engineering creativity and artistic creativity is that it is always aimed at practical results. Art, on the other hand, creates the beautiful, the sense of which, as Immanuel Kant puts it, is the notion of rationality without the notion of purpose. The goal of engineering, on the contrary, must always be clearly defined, tangible and have a roadmap, often involving teams of thousands and investing millions of human-days of engineering labor. Can an opera, a ballet or a painting by an artist be compared to the creativity and complexity of the intellectual labor invested, for example, in the creation of a spaceship or a nuclear power plant?

The situation in which an engineer is a servant causes a series of consequences that are destructive both for engineer and for civilization. As one's work can be guided not by one's own but by the interests of others, responsibility is diluted or washed away altogether. "I have made a sword, and whether it will be used to defend the Fatherland or to kill a baby is the moral choice of the one who takes the sword in his hands." This example can be found in Heraclitus, a philosopher who lived in the 500s B.C. and is considered the founder of dialectics. To simplify, his teachings can be reduced to the formula "everything is relative", which has been the basis of world management for centuries. It has always been believed that good for one nation can be evil for another, that the truth of some social groups can be a lie for others. So, it is possible to lie, betray, kill, etc. This is what politics is based on at all times. Another Renaissance thinker Niccolò Machiavelli formulated such a principle even more succinctly: "The end justifies the means." However, is such a position acceptable for an engineer, if we consider him or her not as a person who has acquired certain skills within his or her profession but as a matter?

If only the goal is clearly defined, the means to achieve it are quite specific and limited, which is rarely the case with political or economic goals. Power has no clear outlines, just as monetary wealth has no clear limits of reasonableness and sufficiency. If a society exists for the sake of increasing

its power, then all means are good. If it exists to increase wealth, it's the same story. But to get to the other bank of the river, there are only a limited number of possibilities, from wading or swimming to building a catapult or a bridge. Moreover, if we remove the first two methods as nonengineering, the choice of options gets even smaller, although still quite big.

From an engineering point of view, the choice should be made in favor of the most efficient solution. It is absurd to carry stones a hundred kilometers away to build a crossing when there are trees all around. It is foolish to build bulky supports and spans when a small raft is sufficient to achieve the same results. Besides the engineer's goal is always clear, it should be achieved in the most efficient possible way. Politics, like an art, needs not be efficient in means. Not only its objective but the means themselves and the effect their application will produce can often be difficult to predict. An artist can draw a square ball or a black square and be recognized as a genius. If an engineer comes up with a car with square wheels, he is likely to be recognized as a madman.

Specificity of goal-setting and requirements to minimize the means of achieving the goal make the formula "the end justifies the means" inapplicable to engineering activity. It is ridiculous to assert, for example, that motion justifies a wheel or that the possibility of speed and automation of mathematical calculations justifies microchips. In general, the concept of justification, whether legal or moral, cannot be applied to technical developments taken as such. Engineering stands beyond good and evil. It helps to solve specific problems as efficiently as possible. It can be assumed that if the tasks were set within engineering, rather than coming from outside as a directive, the nature of the goals driving civilization could change, and the means used would not need to be justified.

For clarity, consider the structure of goal-setting for the same situation from three perspectives: politics, economics and engineering. Let us return to our primitive community living on the river bank. Last season was not the best. Poor harvest, few mushrooms and berries, hunting misfortunes. The coming winter promises famine. What would the politics do? It would suggest we go on a campaign to kill and rob our neighbors. What could economics do?



It could organize trade with a neighboring tribe, trading hides and tools for food. And what would be the solution in terms of engineering? To optimize the consumption, develop and implement the improved methods of food storage, insulate dwellings, create devices for hunting and fishing in winter – skis and snowshoes, artificial ponds for fishing, etc. All three options would potentially allow the tribe to survive. But in the first case, someone would have died. In the second case, the tribe would be deprived of valuable things, and instead would receive resources that would be consumed and disappear irretrievably. Only the third approach could ensure the preservation of what is available, at the same time increasing people's security and creating prerequisites for improving their quality of life in the future. However, both in ancient times and today it is very rare to choose an engineering way of action in a critical situation. Our disunity and the value neutrality of engineering are the determinants.

The underlying value in the case study is survival. In order to live, the community is willing to sacrifice some of its members or wealth. At the same time, the community is not ready for creativity, which achieves better results than all other solutions. Why? Because already at the level of primitive instincts life can be perceived as domination. Life is about winning. To live is to be willing to kill or die. To live to the fullest is to consume as much as possible. All of these arguments are so natural. That is why they work perfectly well in political technology, propaganda and advertising. Against this background, the following statements sound too weak: life is creativity; to live, one must invent; to live fully means to consume as efficiently as possible. However, abovementioned theses are about the creative approach. The first ones are not. The conclusion is simple and bleak. Primitive, almost animal factors of the psyche are more often determinant in the choices made by human and humankind. The mind serves the will. That is a fact. And the way engineering is valued in the modern world follows directly from this. Engineers are servants.

In order not just to change the world but to ensure its harmonious development, it is important for engineering to get over its value neutrality. It is necessary to take engineering out of the position on the other side of good and evil, which can be done only by giving it moral dimension, by conceptualizing and positioning engineering as a good. Such a revaluation opens great prospects for positive transformation in virtually all areas of civilization. And such revaluation is possible.

Civilization established the will as the supreme value. Similarly, before that, faith was the supreme value. Even earlier, at primitive levels of history, survival was the priority. It was pursued either through faith or will; it was embodied first in the pursuit of titles and ranks and then simply in the pursuit of money and power, without any symbolic fixation. Symbolic fixation is necessary in the religious dimension of civilization, in which the symbol acts as an intermediary between the earthly and the divine. Christianity is built around the Nicene Creed¹. The post-feudal world replaces symbolic fixation with embodiment. Meaningfulness moves entirely into the space of the tangible, the corporeal. Symbols lose their stability because the scientific and technological revolution accelerates the whole system so that its fixation becomes impossible. This is the reason for the transition of civilization to the establishment of will as the supreme value. At a certain stage of development of our engineering civilization, it is mind and engineering (as its embodiment) that can take the place of the supreme value.

3.6. Revaluation in Technogenic Epoch

Everyone becomes an individual only in society, and their humanity depends not so much on their personal scale of values as on the society itself, in which they were born, raised and educated, having absorbed fundamental values.

Undoubtedly including the following: both values and life goals, for example, those of Mowgli, fed by wolves, or Indians, raised by a tribe, or Europeans, whose origins sprang

¹ The Nicene Creed is a statement that contains all the basic dogmas of the Orthodox Church. The doctrine is set forth in the Nicene Creed in a concise but precise form; it was compiled in the 4th century by the Fathers of the First and Second Ecumenical Councils. It consists of 12 statements: 1. I believe in one God, the Father almighty, maker of heaven and earth, of all things visible and invisible. 2. I believe in one Lord Jesus Christ, the Only Begotten Son of God, born of the Father before all ages. God from God, Light from Light, true God from true God, begotten, not made, consubstantial with the Father; through him all things were made. 3. Who for us men and for our salvation came down from Heaven, and was incarnate of the Holy Spirit and the Virgin Mary, and became man. 4. For our sake he was crucified under Pontius Pilate, he suffered death and was buried. 5. And rose again on the third day in accordance with the Scriptures. 6. He ascended into heaven and is seated at the right hand of the Father. 7. He will come again in glory to judge the living and the dead and his kingdom will have no end. 8. I believe in the Holy Spirit, the Lord, the giver of life, who proceeds from the Father [and the Son], who with the Father and the Son is adored and glorified, who has spoken through the prophets. 9. I believe in one, holy, catholic and apostolic Church. 10. I confess one Baptism for the forgiveness of sins. 11. I look forward to the resurrection of the dead. 12. And the life of the world to come. Amen [57].

in Ancient Greece and Ancient Rome, Russians, who had their roots in paganism, will be completely disparate.

Since the values and goals of each society are different, the problems that arise during their implementation will also be radically different. That is why the proposed solutions for achieving the set goals cannot be the same – they are often opposite and even antagonistic. This means that the logical chain being built “basic values – set goals – emerging problems – optimal solutions proposed to settle problems” will have a completely different orientation, boundaries of implementation and time length, depending on a particular society.

Since our Earth's technogenic civilization as a whole (as a combination of all societies, as a mega-society consisting currently of 8 bln individuals living in 195 independent states, nine states with an uncertain status, 38 dependent territories, three territories with a special status, 16 territories without permanent population, 22 territories of states considered an integral part of them, but belonging to another part of the world, and two territories disputed by several states) is at the top of all social structures of humankind, then by itself it should become the greatest value for every person. At the same time, the general civilizational values of this mega-society should be only biospheric, since our civilization was born, grew up and turned out to be “registered” with billions of other species of living beings in our common house (or rather, in a large room that has no windows, doors or even partitions) – in the biosphere of planet Earth.

Ultimately, the issue of the humankind's survival, which has arisen against the background of global environmental problems characteristic of our time, is an issue of certain values that drive us all. At the same time, the technological equipment of a civilization functioning on the planet as a global multibillion-faced technology consumer will play an incomparably smaller role than the intangible civilizational components – social, moral, ideological and spiritual aspects. No technical devices or ideas aimed at rationalizing people's lives, protection of the environment and well-being will be implemented if there are no corresponding socio-spiritual values in the society.

On the other hand, the appearance of certain values is due to the specifics of the relations between people into which they enter during the production, exchange, distribution and consumption of the social product. However, this does not make the role and importance of values in the life of society any less. Yes, a change in technical equipment can contribute to a change in values. Yes, values are secondary, but they are what ultimately make humanity change.

Even this approach recognizes the overriding role of values in the processes of social transformation.

Value is something indicating “the human, social and cultural significance of certain objects and phenomena, referring to the world of the proper, the target, the meaningful basis, the Absolute. Values set one of the possible ultimate limits of human sociocultural activity” [58]. Based on this, we can say: it is values that will determine the nature and direction of society and culture in the future, just as they did in the past.

By the 21st century, the world has survived a number of value crises. The most general view gives the following picture. First, the denial of the values of traditional cultures based on religion. Then there is the denial of the values of technological progress due to disappointment in the consequences to which this progress has led. Next – the rejection of values offered as part of three ideologies of the 20th century and their corresponding systems: nationalism (including fascism), socialism (including communism), capitalism in various versions of its existence. At the same time, in reality, the latter model (capitalist) still retains its position and dominates the world. However, it is experiencing a prolonged depression, primarily noticeable on the leveling of the inherent value system in capitalism.

Initiative, entrepreneurship, success, wealth, competition, free market – all this began to look very dubious against the background of environmental and social problems that result from the behavioral mindsets arising from this. But in reality, humanity is yet unable to generate anything fundamentally different, equally massive and attractive. As a result, the value structure of civilization, its sociosphere, acquires a relative character. There appear all kinds of surrogates and mixes that combine elements of political, religious, scientific and ideological doctrines. Everything is presented as relative, situational, acquiring meaning only in the context of a particular discourse.

The society finds itself deprived of values other than those that relate to the lowest material level of consumption. “I am what I have” [59]. This is how Erich Fromm, author of the term “consumer society”, described the current situation. In fact, such a society is inert, since it does not have a goal set by the values that the majority shares. So, it doesn't have a future either. The people in it, as Fromm noted, are just “eternal suckling crying for the bottle” [59].

The things that today's degrading capitalist liberal world offers to replace values, and specifically inclusivity, confirms the above. The relativity of all values is put forward for the role of the highest value.

Consequently, the requirements of tolerance and equality in all forms of its manifestation become determining for the development of society. Thus, equality is indicated between the guiding principles of opposing ideological doctrines, religions, social and gender groups, cultures, traditions, i.e., the nature of what is happening corresponds to the formula "everything equals everything". Obviously, such mindsets cannot act as "the ultimate limits of socio-cultural activity" [27]. The horizon of the activity they set and the goals they dictate will, in fact, be focused on nothing more than preserving the status quo. No orientation, no transformations, no qualitative development is possible here – constructive, creative, interactive, coevolutionary – because humanity should not only change nature but is also obliged to change itself, adapting to this nature.

Against the background of environmental, political, social, spiritual and other problems, on the solution of which the survival of humans as a species depends, the values of the 21st century (more precisely, anti-values, since they devalue everything) resemble a sleepwalker, completely disconnected from life. Suddenly waking up (which sooner or later happens), they do not understand the situation they are in. Or, without waking up, they die, falling into the abyss, never realizing at the moment of their fall what really happened to them.

Yes, it can be stated with sufficient reason that in this universal relativity, as in the point of view on the world, the attitude to nature is also being revised. The ideas of equality of all species of living beings are postulated, an ecological imperative is established, setting the creation of a carbon neutrality economy (net zero) as a goal. However, all this is nothing more than a call to achieve the most stable state of the capitalist system and the society of material consumption but not civilization as a whole. At the same time, such a system of universal consumption, which has recently taken a tilt in the direction of virtual emotional consumption, including through the step-by-step transformation of a biological person into a digital cyborg, is initially imperfect in its fundamental parameters. Thus, the possibility of achieving the desired stability is highly questionable. And in general, such concepts as "value", "goal", "achievement", "problem", "solution", cease to be adequate to the situation. The words "business plan", "task", "execution", "optimization" become more appropriate here.

The values of society should not only provide conditions for preservation, they are also needed as a horizon of growth. If this is not the case, then we are no longer talking about "value" but about "cost", which, apparently, is inherently closer

for capitalism and inclusive capitalism advancing on humanity. In order to explain what has been said, it is necessary to look even deeper into the history of the issue.

For Antiquity and the Middle Ages, this topic was incurious. At that time, people's worldview was made up in the system of religious coordinates, focusing on the corresponding goals, priorities and prospects. Values are something else. People start thinking about them when the medieval traditional culture dies out. It can be claimed that the problem of values arises in a situation of devaluation of former values and their reassessment. This process was deconstructed by Friedrich Nietzsche. Let us look at it.

The value according to the Nietzsche's assessment is the point of view, i.e., the point at which the eye of the beholder is located and from which his attitude to the world is projected. At the same time, the value as a point of view always means a condition of preservation and growth [60]. It has a dual character because of the life's nature itself, where the value should be a part of it. Nietzsche defined this essence as the will to power, which drives everything in the world, including human. If this will weakens, if the value does not reflect its dual essence and does not allow the power to surpass itself at every moment, to grow, then the being led by such values begins inevitably to degrade and rushes to its death.

Despite the apparent complexity of such a mental construction, its meaning is simple and clear. The thing that ceases to grow and develop dies.

The described process is already happening in the 21st century in liberal culture with its pseudo-values that make everything relative, thereby depriving society of even the possibility of choosing the direction of development. Everything happens as in the situation when you need to get to a certain place located in the north. To do this, you need to know where north and south, east and west are, so that you can move in the right direction. If you start to reason and act in the way that south and north, east and west are relative, then in the end it will turn out that there is no need and nowhere to go; you just may lie down and die because life and death are also relative.

Values, according to Nietzsche, are a point of view precisely because they (unlike the external Absolute) should originate from a person and be set by him as a carrier and manifestation of the will to power. A person here, acting as a fundamental condition, is obliged to realize his own "value" [61]. No matter how strange it may seem, but today *Homo sapiens* is not actually considered as a "value". Although the opposite is widely claimed. However, only in form.



The essence is correctly noted by Professor Olga Garaniina, who wrote that "anthropological centrism, expressed in the dominance of humanistic values, strife for the affirmation of life and signifying the biophilic life-value orientation of a person, is being replaced by technical and informational utilitarianism, which does not require direct human contact, depriving a person of emotional intimacy and spiritual mutual enrichment. In the structure of the modern anthropogenic world, technogenic elements are gaining dominant importance, as a result of which the value of living structures is leveled out. The space of natural life narrows under the pressure of artificial, technical objects, in communication with which kindness, mercy and compassion are not required" [62].

The following is extremely important: the basis of the assumption of values, according to Nietzsche, is the structure of the will to power. Only in this way the established values

lead to survival because life through the will to power lies in their very essence. Without this, any values, and, in particular, the pseudo-values of the 21st century, not only turn out to be unviable by themselves but also lead to the destruction of the society that is guided by them.

It should be further clarified that the Nietzschean concept "the will to power" implies something much deeper than the desire of some people to dominate others with the help of force, politics, etc. "The will to power says that the Existence "is present," i.e., something through what it dominates (as power)" [61]. This is a kind of internal driving force of all living things, something that was at the heart of the Big Bang, and something that makes a blade of grass grow through the earth, fighting for a place under the sun with other existing things. Close to this concept is the key concept of the philosophy of Arthur Schopenhauer "the will to live", by which he understood the aggregation of "blind and irresistible"

desires that form the essence of our individuality: it is them who ensure the reproduction of individuals and the continuation of the genus [63]. The values that give life are assigned to stand on this basis.

Humankind and every person must strive to overcome, gain a victory, be stronger but not act as proposed in the modern world of liberal structures: to understand and forgive, to live without any goals, without procreation (this way of behavior is indirectly called for by the ideals and goals of human existence imposed by liberalism), without understanding of oneself and society as an intermediate entity on the path to perfection – something that will always need to be surpassed, but not equalize and talk about the relativity of everything and everyone.

Since values are conditioned by human and humanity, which are carriers and manifestations of the will to power and the will to live, no values can be final, the process of their assumption and depreciation is continuous and occurs as once accepted virtual values cease to be applicable to the real world. In this case, the world itself becomes devalued [61]. It is obvious that this is the situation of world depreciation that we are witnessing in the 21st century.

Tolerance, equality, lack of spirituality, relativity, rights of animals, ecological imperative – all this, perhaps, provides conditions for conservation but does not provide space for growth. Consequently, such values are simply inapplicable to the world of technogenic civilization with all its contradictions and problems – primarily environmental ones caused by the technosphere. Once again: values ceased to be applicable to the world, and the world itself began to seem devalued. The assumption of new values, the overcoming of nihilism is necessary in this situation as a condition for the survival of humanity and billions of species of living organisms inhabiting the planet.

"The reassessment of all previous values should be carried out and approved on the basis of the maximum awareness of one's own consciousness of the value essence and the assertion of values," Martin Heidegger explained one of the key points of Nietzsche's doctrine [61]. The value essence of human and humanity is determined, as already mentioned, through the will to power. The essence of values is the provision of conditions for preservation and growth. Thus, having briefly considered the history of the issue in the 21st century, we can systematize the general conditions and requirements for the civilizational values that need to be approved and comprehended:

1) applicability to the modern world, adequacy to the real state of matters, problems and opportunities;

2) affirmation of the priority of human life and fundamental freedoms (as a carrier and manifestation of the universal will to power rather than, for example, as a carrier of the attributes of a particular social or gender minority);

3) consolidation of everything created by civilization during the previous millennia up to the present time and ensuring the preservation of the achieved level in the material and spiritual spheres of social life;

4) designation of directions and opportunities for further comprehensive material (technogenic) and social (spiritual) development of each human and humanity as a whole.

Proceeding from the above requirements and looking at the issue from the standpoint of all humankind, which has entered the turbulent global stage of its existence on the planet long ago, when the interests and actions of some countries and peoples are closely intertwined with all others, the approval of new values should also be conducted on a planetary scale. Only such an approach can be adequate to the global problems and challenges we are facing in the 21st century. If we accept the second point from the above list of criteria and agree that only humans can be put as a triune biological, social and spiritual matter and only as a subject of the will to power, then there can be no question of limiting them anyhow in that respect. And finally, if anyone should not be limited in their essence and at the same time should have a horizon of development, then such a person reveals to us only in engineering. Only engineering can enable humanity to gain more while preserving what it has.

3.7. Dictatorship of Engineering. Supreme Value

Engineering is the embodiment of human reason and rationality. The functions commonly attributed to rationality can be summarized as follows. When the dispute between reason and sense is resolved in favor of reason, it acts simultaneously as a ground of being, as an instrument of systematization and as a goal-setter. Such is rationalism in the strict sense, in particular the rationalism of René Descartes, considered a classic example. In cultures that prioritize the sensual world, rationality retains only systematizing and goal-setting functions. Finally, traditions that attempt to stand on the other side of reason and sensuality, matter and idea, good and evil reserve only the systematizing function for reason. Here something super- or extra-intelligent is taken as the basis and goal.

Rationalism in its purest form is realized only in refined philosophical doctrines authored by people like the aforementioned René Descartes. Europeans know only three

types of cultures: sensual, anti-rational and voluntaristic. By sensual I mean Antiquity with its cult of corporeality and reasonable goal-setting. By anti-rational – the Middle Ages with the dogma of the priority of faith over reason. By voluntaristic, I mean New Europe, driven toward the abyss by scientific and technological progress.

Rationalism in its purest form is impossible because reason must be embodied to become the basis of being. In Descartes' time, it did not yet exist tangibly because engineering and technological devices determined people's lifestyles and affected nature disproportionately less than in the 21st century. By the time this text was written the mind has been embodied and it continues to gain mass in technology and engineering products. However, despite the fact that the products of mind are crucial for the fate of civilization and its survival, mind itself is not yet perceived as the highest value.

The world is still not reasonable. Therefore, the products of intellectual activity, subject to spontaneous will, exist in an uncontrollable and almost chaotic mixture. There is reckless consumption of the planet's resources, and people continue to underestimate embodied intelligence, dreaming of limitless sensual pleasures. Those who believe that engineer, and therefore the embodiment of intelligence, is a servant. This assessment is characteristic of engineers themselves. They accept the humiliating position of servants. They think and act like servants.

If civilization alone retains the survival instinct, the balance of values must change. Engineer must rise to the pedestal. Engineering must establish itself as the supreme value.

Is it possible to imagine the creation of the atomic bomb in a situation where engineering is something identical with good? If an engineer is a servant of the good, and using the power for destruction is a morally and legally condemned crime, a sacrilege equivalent to theft or murder? It is impossible because such a development requires enormous effort, huge funding and the consolidation of society. If society's values do not allow to promote murder through engineering, it will not unite around the creation of weapons.

If engineering takes the place of such values as equality, democracy, sovereignty, quality of life and more, all these values will no longer be reference points but will become a reality. In other words, engineering is the reality today, and the reality that unites everything around it. Nevertheless, it has a servicing status. Liberal values are a virtuality. However, this virtuality subjugates everything that is real.

When we swap the real and the virtual, the virtual will become real.

Why, for example, is there no equality? Some people lack something, some want more than they have enough, some want to dominate others... How can we achieve equality? By restricting everyone's rights equally. Is this possible? Unlikely – because some are strong and some are weak, rich or poor. But what if everyone was not trying to agree on acceptable limits but instead set a goal, on the contrary, to push the boundaries as far as possible by technical means? There would be no need for equality. With an abundance of everything we need – food, space, luxuries, etc. – hardly anyone would infringe on the rights of others. This is confirmed by the experience of rich countries. The richer one is, the less the reason is to offend anyone. Only now wealth is created by robbing each other and nature. If engineering improvement became a goal and value, wealth would arise and accumulate evenly. Available to all.

How is this world that has realized the value of engineering supposed to work? Where will the politicians, the banks, the corporations go? They will remain, obviously. But they will not be an end in themselves but a function. What (or rather, who) can make them give up the will and power with which they have fused over the centuries? Only engineers, into whose hands the will and power must pass to be overthrown for the glory of reason.

In fact, engineers already rule the world. All key resources and tools are directly in their hands. They keep the various machines, factories, utility systems, transportation and defense complexes running. With the full power of civilization at their direct disposal, they manage it on orders. Above them stand those who have nothing real behind them but only a thirst for power and wealth, backed by account numbers stored on servers created and maintained by engineers. Viewed in this way, the picture appears phantasmagoric. Those who have everything have nothing, and those who have nothing possess everything. The unreasonable commands the reasonable. People in the first quarter of the 21st century are ready to recognize this. On the other hand, they have everything at their disposal to change the world by establishing the dictatorship of engineering.

3.8. Engineers' Dream

How can engineers take power? They will not build barricades, no matter how good they are at it, will they? We can look at the ways in which the lower class has

taken and whether it has actually taken the power. Through revolutions and civil wars. Who actually occupied the offices of the Kremlin? The revolutionary intelligentsia, who as planned put themselves in selfless service to the interests of the workers. And Joseph Stalin, for example, spent half his life wearing the same overcoat indeed. He built a society of justice. And he did not consider sacrifices. Industrial labor, set as a value, gave society a creative impulse, which allowed, having survived a ferocious war, to endure and develop advanced technologies that made it possible to send a human into space for the first time. It means, there is already a precedent when the type of activity and its product turned out to be decisive and were put on a pedestal of universal reference point. It is logical that against this background a powerful industrialization was carried out.

Despite all the failures of the Russian communist project, it was a colossal experience of realization of the plan on the scale of 1/6 of the land. However, the so-called basis in Russia was not prepared. It took too much effort and sacrifice, which eventually led to its downfall.

The 21st century is the time of utmost readiness for a meaningful global transformation. Engineers have at their disposal all the possibilities for reasonable ordering of the world and bringing it into balance. However, technology is managed by politicians, bankers, corporations and officials hired by them, including presidents of countries, who appropriate the products of engineers' mental labor. If Vladimir Lenin were alive today, he would say that engineers must revolt. Then they would shout "Rob the robbed!" and burn down the skyscrapers of transnational companies. That scenario might happen. The situation has escalated and the survival is at stake again, as in the primitive times. The survival of the tribe called Earth's Human Civilization.

An uprising of engineers is inevitable. The worse living conditions get, the more wars and pandemics will be, the less chance of survival is, the more hopes will be pinned on engineers. Admittedly, it may be too late. But even then, at the last moment, the very last hope will be tied to an engineer, able or unable to start a fire. Either engineers will rise, or a reasonable power will be found in the world that will raise engineers itself. Otherwise, our Earth's civilization, which is essentially engineering, is doomed to perish. However, at present there seems to be no prerequisites for such civilizational reforms.

Engineers as intellectuals who determine the development of civilization appeared in sufficient numbers and formed

into unions, communities, associations and academies in industrial and postindustrial societies. There are two main theories describing the structure of these societies: class and stratification. The first theory divides society into the bourgeoisie and the proletariat, with a thin layer of intellectuals in between. Engineers belong to it. Strata are layers divided not by ownership of the means of production but by income level, education, status, professional affiliation, etc. The postindustrial era is the time when the society is divided into strata. In the postindustrial era, engineers are the middle stratum, and they occupy a subordinate position to the pseud-elites. "Elites" appropriate the cost of their work, means of production and resources – they take away everything. They grow rich and decide the fate of the world without any clear goal. After all, wealth cannot be a goal because it is incalculable and has no limit. It is the same with power. The "elite" does everything to destroy all the superfluous as soon as possible. And everyone sees it, and tolerates it, and accepts it.

Engineers in the 21st century are philistines and consumers. They are part of a herd of sheep being led to slaughter. They go to work and shopping, play computer games and watch TV like any other techno-consumer of the global consumer society. They are paid enough to satisfy their small philistine needs. They are satisfied with themselves and their fate. At the same time, every day their labor is aimed at maintaining the unreasonable anti-natural structure of the social system.

There's a scene in the movie Terminator 2. An ordinary American engineer at work, in a rich house, with his wife and child. He's surrounded by a nice household. He has a good education and career. The character gets a big paycheck. Without knowing it, he's developing a chip for a machine that will destroy humankind. The engineer is asleep. What could wake him up? Calamity. And that calamity is relentless. If we don't wake up now, it will come to the irreversible – humanity will be destroyed in a catastrophe in which the quantity of global problems created by society will turn into a new quality. No humanity – no problems related to it.

3.9. Engineer's Moral and Ethical Code

Given the role that engineering plays in our industrial civilization, it can no longer stand outside of morality. At some point, technology has become a determining factor in the survival of nations, peoples and humanity as a whole. It may also turn out to be the main cause of the death of individual societies and the majority of the world's population. The lives and health of people depend on the actions of engineers,

and therefore, when entering the profession, they must assume moral responsibility, just as doctors do. An engineering version of the Hippocratic Oath – an engineer's moral code – should be developed and implemented in one way or another. Attempts to create such a code have been made before.

The Code of Conduct of the British Computer Society among the rules of conduct for a member of the Society includes the following: "He shall have due regard of the impact of computer systems, to the extent that he is aware of it, on the exercise of the fundamental rights of individuals, whether these rights are exercised within the organization, its customers and consumers or the general public. A member of the society shall pass on the information available to the client in order to help him understand situations that may arise with the potential harm to a third party. He shall combat ignorance of the kind of technology he is engaged in, and especially in those areas where the application of that technology appears to have dubious social merit" [64].

The Code of Ethics of the National Society of Professional Engineers of the United States says: "Engineers shall hold paramount the safety, health and welfare of the public. If engineers' judgment is overruled under circumstances that endanger life or property, they shall notify their employer or client and such other authority as may be appropriate. The ethical standards governing "engineer – employer" and "engineer – client" relationships require the good faith fulfillment of business obligations: to provide the client or employer with what one has promised to produce; to complete work on time and within budget and, if this cannot be achieved, to alert the client or employer as early as possible so that corrective action can be taken; not to disclose, without consent, confidential information concerning the business affairs or technical processes of any present or former client or employer... Engineers using designs supplied by a client recognize that the designs remain the property of the client and may not be duplicated by the engineer for others without express permission" [64]. However, there is something missing in all the versions presented. The precepts are inconsistent and seem to ignore the actual role in civilization that engineers play.

Engineer's code should be built from the perspective of supreme values and include universal rather than professional provisions.

1. Engineer is called to change the world.

Changing the world by engineering is a constant and irreversible process. Understanding this must be coupled

with an awareness of responsibility. Engineers have more reason than anyone else to control the world. Their role in the world is to organize the most efficient interaction of substances, objects, mechanisms, devices, technologies, people and societies to achieve practical results. Engineers truly rule the world.

2. Engineers shall know and respect the history of the profession and honor their teachers.

Without knowledge of the history of engineering, it is impossible fully to understand the significance of this phenomenon. Nor is it possible, without studying the experience of predecessors, to avoid repeating their mistakes. Only by looking at the overall picture it is possible to see how haphazardly and in spurts the technologies were developing. The growth of engineering was not subordinated to any general plan or purpose; therefore, the chaotically growing Earth's industry came into conflict with Live Nature, bringing civilization closer to a fatal ecological catastrophe.

Acceptance of the history of one's profession should be through teachers as bearers of knowledge vital to all humankind. The status of the teacher in society, and especially in the eyes of pupils, must correspond to the extent of the teacher's vocation.

3. Each engineer, as an elementary genetic unit of a living organism – the Earth's engineering civilization, determining its existence and development, shall serve the good of the whole universal society, not its separate part.

When creating (developing) engineering solutions, the author should not be guided only by personal interests as well as the interests of other people of any communities. The primary goal of any engineer is the good of the entire human civilization. The good of humanity is the preservation of life and improvement of the quality of life of all members and strata of all societies inhabiting planet Earth, without any forms of birth control and life expectancy restrictions, including all possible forms of genocide and segregation.

4. Life in all its manifestations and biodiversity is the engineer's supreme goal.

An engineer should formulate and accept only those goals, which contribute to prosperity of life in our all-civilizational home – the planet Earth's biosphere. Creating devices to destroy life is unacceptable as it goes against the essence of engineering. As a form of creativity, engineering must accomplish transformation without destruction and cannot serve to destroy life either locally or globally.

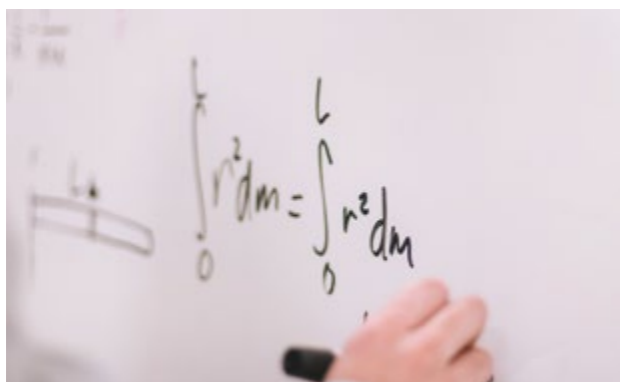

The potential consequences of the operation of the devices created by engineer are also important. Indirect killing must be avoided as much as possible.

5. Engineering is the highest value of civilizational life. Engineering becomes a supreme value at the moment it incorporates a moral dimension and takes as its goals the service to life and good of humanity. The definition of engineering as the human activity of transforming the reality around us is complemented by the fact that this activity is aimed at achieving and promoting good and therefore is opposed to evil. Engineering encapsulates value not in itself but in serving life by identifying with it and accepting its own inner limitations. On the other hand, life becomes a measured engineering and mind acting through it as its embodiment. The noosphere of the planet (the sphere of reason), which is the civilizational development of the biosphere, is formed.

This provision should not be taken indiscriminately and extended to all people. We are talking about the value of life as a universal asset. At the same time, everyone can and should have their own values in their life. Engineering serves the general reasonable arrangement of life so that all can find their place in it and choose their own reference points.

Without putting forward and adhering to the above principles, the world is doomed. Engineers will inevitably continue to act. If engineering remains morally neutral and does not become a regulator, the consequences of these actions will either destroy all living and natural things, replacing them with inanimate and unnatural things, or destroy our civilization, which we know and are a part of, because a degraded and thinned humanity that has returned to a primitive way of life can hardly be called a civilization. It is also possible that both scenarios will occur at the same time. Value-neutral engineering generates false directions of development leading to the death of civilization.

3.10. Necessary Education for Engineer

We have described above that today's world for its survival can and must be interpreted as a new living and creative project managed by talented scientists and engineers. False directions in attempts to reorganize the world have led and are leading us to monstrous catastrophes. Pseudo-scientists who carry out their experiments solely for the sake of the experiment itself, so-called capitalist elites for whom personal ends always justify any means, fanatics devoted to serving the ideas of their own power, cynical economists

and politicians who talk about the improvement of society – all these are the servants of an infectiously dangerous and vivid phantasmagorical world².

The consciousness of these usually charismatic and rational people is always self-centered and sees no other reality in the world but their own. Such consciousness does not know true values at all and, being immature, is incapable of true creativity.

Together with the long process of secularization, modern secular society has been deprived of a deep inner spiritual dimension in which, on the one hand, humans were aware of their mortality and, on the other hand, felt a sense of belonging to a reality of a higher and more meaningful order. Ritual practices and religious symbols, as well as wisdom rooted in the national past, were attuned to this spiritual reality in society; the meaning of human in the world was defined as service in a place of temporary habitation, followed by the heavenly world.

The qualities that the spiritual traditional society fostered have been completely forgotten in the 21st century. In the consciousness of a European-type human, the individual and personal are superior to the universal; self-centeredness and self-love are normal properties of a "developed" personality; insolence, ambition and licentiousness of manners are better than faith, modesty, respect for elders and self-critical attitude. The world justifies and legitimizes human passions and pleasures, substitutes good for evil or levels moral categories, declaring them relative. Humans know only their own and accepts only what they need, and the world around is a mean of satisfying endless needs that do not know quenching and satiation, both material and informational, always having material carriers. Humans do not strive for self-overcoming, and mass culture from childhood persistently urges not to go beyond the consumerist attitude to life, to accept and defend themselves as they are, to develop only for increasing their value on the labor market and to monetize skills in order to reach the maximum scale of consumption.

Since the time of Cartesian binary logic, the "separation" of the world has been internalized and subject-object relations

² "The lust of greed and love of money for its own sake creates one of the most fantastic worlds, furthest removed from the real world of being – the world of capitalism, of banks, stock-exchanges, paper money, cheques, IOU's, advertisement, competition and pursuit of easy gain. The financial world is a terrible phantasmagoria, utterly remote from the world created by God and adding nothing to its richness, fullness or perfection. Leon Bloy was right in saying that finance is a peculiar kind of mystery-play," wrote Nikolas Berdyaev in his book "The Destiny of Man" [55].

have been asserted, to the point where people can destroy the earth they walk on and live on without feeling that they belong to it. Because the thought is firmly lodged in the consciousness: "The earth I walk on and the planet I live on are not me. I am the money in the bank, the house, the car, the devices and other things that I have somehow acquired and have." This trend in the world must be countered by the simple and sobering realization that the world, like all living things, requires attention, special care and careful handling.

Indeed, how can engineer have a moral and ethical code if it is not specially formulated? In physics and chemistry textbooks for schoolchildren you will find theoretical knowledge about the structure of matter, various ways of interaction of bodies and practical illustration of physical laws. Where is the respect for the profession, including teachers, where is the service of the profession for the benefit of humankind and life as the highest value that needs to be preserved? The teacher in the 21st century is no longer perceived as a pedagogue but as a manager of educational services. The vast majority of parents and children, after them, treat teachers as if they are in their personal service and has no respectable professional status. With this attitude, students will learn nothing. Instead of serving humanity, they are propagandized to follow purely personal goals and interests. Young people may dream of contributing to the achievement of universal goals at an early stage, but these dreams are mostly not widely applied in society and are not nurtured in the existing education system.

Everyone first builds their own career and personal life and then, as he or she imagines, will start to "help the world". However, this moment rarely comes because the priority of one's own tasks is always higher, and security is always not high enough. Life is also not the highest value for human, and so engineer can invent and participate in turning rivers, producing means of mass murder, dangerous pathogens and vaccines, machinery and equipment that pollute the air, soil and water without questioning the morality of such a process. This happens with the silent approval of the consumer society, which also needs to provide for its own needs first and foremost. In order to eradicate such an attitude and to educate moral engineer of a new formation, a fundamental revision of the education system is necessary. As an example, it should be introduced into the field of study along with technical sciences:

- humanitarian disciplines, including those at the intersection of scientific and technological and philosophical understanding. In particular, "Ethical bases of interaction

between human, machines and biosphere", "Bioethics", "Civilization and planet", "Cosmism and noosphere" and others;

- religious and philosophical teachings. Undoubtedly, an individual has the right to believe in what he or she considers worthy of his or her faith. However, the task of the educational system is to familiarize the forming consciousness with the basic ideas and principles of moral and ethical doctrines. At the very least, this will help in understanding that the world has some spiritual dimensions and that it is more complex, deeper and richer than the surrogate imposed by mass culture.

Education is something everyone is involved in. Through education, a socially oriented person is formed. At any moment of time. And that is why all reforms here and now should start with education. In the devices, machines and technologies the engineer designs, he must effectively combine and use knowledge from various fields not only of science and technology but also of society (thanks to which, in fact, our human civilization was created), which differs significantly from the civilization of an ant hill, a bee hive or a flock of dolphins.

Civilization did not appear by itself – it was created by engineers, whose achievements were used not only by them but also by the whole society – first by tribe, then by nation, state and humankind as a whole. Consequently, we can rightfully assert that our Earth's human civilization is engineering by the way it was created, and not technogenic, technocratic or industrial, as it is now called. "Engineering", "technocracy", "industry" are not the essence, they are symptomatic. A real doctor does not look for symptoms, which are visible to the naked eye, but for the causes of disease. A doctor who knows not only the symptoms but also the whole human body, who understands what health is, will be able to cure the patient.

The moment has come when engineer needs to start acting in the moral dimension as well. Ethical considerations must be incorporated into the structure of engineering action along with technical and scientific considerations. The task of education is to instill this understanding, thus providing the conditions for a reassessment of values and the triumph of engineering as a purpose-driven beginning to save the world.

3.11. Power of Engineers

Engineering can and must become the benchmark of power as a supreme value. Out of this, the political and economic order must be reformatted in the future. Politicians and bankers will perform a service function for engineering,

not the other way around, as it happens now. This reformatting must happen evolutionarily, without upheaval or revolution, i.e., without fanaticism. Never before have good civilizational goals been achieved through plunder, wars and revolutions.

Engineers have created and concentrated incredible technological resources in their hands. They actually control them. It is enough to define a goal and achieve coordinated action to reconfigure the entire system with one deliberate action. A longer way is to undertake a series of acts aimed at a civilizational reset. In the digital age, when everything is controlled by information, we have everything we need for this.

A hundred programs focused on transforming major economic sectors such as agriculture, energy, residential and industrial infrastructure, transportation will be able to set new algorithms for political and economic interaction. These programs can be implemented by engineers themselves through communities and computer products. Humanity has had such experience by the 21st century. Electronic services such as Google or Facebook have already changed the reality. They did it in a short period of time. The main problem is that this engineered product ultimately served the values of the capitalist system. It was designed for enrichment and consumption. New products can be creative, tied to engineering projects on a global scale.

The technologies developed by engineers also include new financial instruments. In the 21st century, a crowdfunding mechanism has been created that allows a large number of people to jointly finance new engineering developments. If we divide the cost of even the most grandiose engineering structures by the population of Earth, the sums can be negligible. For example, the cost of the International Space Station is 150 bln USD. This is less than 20 USD per inhabitant of an eight-billion planet. The US defense budget for 2023 is almost 900 bln USD. And even 110 USD/person per year is not a lot of money.

Theoretically, with 100 USD (27 cents a day) annually, it is possible to equip an army that is not under the control of any country. Financing of large programs can be carried out here without state participation. And the society united by technological goals will itself become a subject of politics on a par with the state but without "leaders", "chiefs", "elite" and all others, who appropriates not only a part of people's income but also natural assets of entire countries and results of intellectual labor of their peoples.

Entering into technological competition with states and global corporations, the engineering community is able to offer universal solutions that are more effective than

those made on the basis of interests and benefits of some isolated groups of people. At this level, it is no longer a question of robbery, war or revolution for the sake of power and enrichment. Common interaction and common financing are possible only around particular, constructive and practical targets. Only engineering can offer such goals.

As a result of the competition between creative and destructive engineering solutions, the former will inevitably win. In the end, they will be accepted by everyone and spread everywhere. The fact that such more efficient and unified devices, systems and algorithms have not yet appeared in the first quarter of the 21st century is explained by the lack of real competition. The right to technology and to large technological projects is concentrated in the hands of the "global elites". They pursue their clan interests, and efficiency is not favorable to them.

The more complex and power-hungry a device is, the more substances and energy rotate in it, and the more it consumes. The more it takes to run the infrastructure, the more it sells and buys. The more extensive the trade, the grander the profits. "Elites" who have access to resources (it does not matter what – raw materials, technology, humans, etc.) cannot be interested in achieving high efficiency – it would mean lower costs and therefore lower revenues. That is why tools are needed to enable engineering with its specific and inherent manner of goal-setting to compete with the obviously voracious systems produced by capitalism. Fortunately, in the 21st century, engineers have been able to create such tools.

It is enough to create effective global engineering systems in key sectors of the economy adequate to the level of development of science, technology and society of the 21st century to achieve the goal. The revolution will be unnecessary. In the ideal but possible situation of the future, in which we have unlimited resources of space at our disposal, money speculations and wars will become a senseless anachronism. Politicians and bankers will begin to simply fulfill their functions as plumbers and electricians, janitors and waiters. Even if this will not happen overnight, it will come true step by step, as soon as engineering has a purposeful force in the development of society.

The inevitable need to recognize engineering as one of the highest values may lead to a different scenario. In this case, one of the states voluntarily, with the support of its citizens, starts to consistently implement a comprehensive program for reasonable engineering reorganization of transport infrastructure, urbanism, energy and agriculture on biosphere technologies that are already

available – they are developed and tested by the international Unisky Group of Companies, which already employs more than 1,000 engineers. In this case, such a state will boost the economy many times over and become a world leader in the creation and implementation of highly efficient and environmentally friendly industry-forming products. However, for this purpose the country must have real sovereignty and absolutely not depend on the interests of global political and economic centers. Is there such a state in the 21st century? By the time of writing this text, the question remains unanswered.

In any of the presented scenarios, the power of engineers will not be exercised directly and owned by any group of people. The power will be a universal goal-setting that is shaped by engineering rules that require specificity and efficiency. Engineers will continue to serve their machines so that the machines will serve all people without harming Live Nature. The rest of the society will serve itself, including engineers, providing their needs and opportunities to realize their ideas. This is the only way to achieve harmony between machines and people – by linking them in a common cycle, breaking the historically established system in which engineers and all others serve the rich and kings, creating for them whatever they want, even their own gallows and guillotines.

The fact that engineers should not and do not want to lord it directly is important. No one, no group of people should lord it over another. My statement is rooted in engineering logic. If society, civilization is a super-complex system, then no part of it should be determinative. There may be significant and less significant elements, there may be elements without which the device will cease to work, but there cannot and should not be a part for the sake of which the whole mechanism would exist. From an engineering point of view, this is absurd. Any engineering device, including the engineering component (industry) of our civilization, must have a meaning of existence beyond itself. Just as a car serves for transportation, a house serves for protection from wind, rain and cold, and a refrigerator serves for food storage, so civilization as a complex engineering device should serve the survival and development of humankind, not the enrichment of anyone, be it even the most outstanding engineer. Only by uniting around engineering goals and objectives, people can achieve this in the conditions of the 21st century.

A similar synergy can be observed in our body. What is the most important thing in it: the heart, kidneys, lungs, brain or intestines? They are all important because their

totality plus consciousness, spirituality and reason (as their common function) is what makes *Homo sapiens*.

It may seem to some that a model is being proposed in which humans serve machines. Yes and no. One might ask the same silly counterquestion, "In our organism, does the brain serve the gut or does the gut serve the brain?" They do not serve each other and they do not owe each other because they constitute a single whole living organism. So our engineering civilization is a single biotechno-socioorganism.

People will not cooperate with machines that poison nature, kill and deprive them and their children of a future. People will deal with machines that help and care for them. And it will not be a service but a care, just as we care for the garden we plant or the pets that live in our home. The way a race car driver cares for the engine of his car, and an artist cares for the brushes and easels. They take care of things that take care of them and harmonize their lives. If in the 20th century the relationship of master to slave was formed between human and objects – worthless and inefficient – in the future, when engineering developments are improved and filled with value, the relationship to them can be conceptualized as a partnership. This is a reasonable civilization pattern that does not require any upheavals for its establishment but only awareness, will and revaluation of values.

The dictatorship of engineering by the middle of the 21st century cannot be established in the course of an open social revolution. It is a long process. Technologies are becoming more and more advanced and interconnected. Engineering thinking is becoming more and more global. Realizing deeper and deeper the significance and possibilities of the knowledge in their hands, engineers try to apply it on a planetary scale, making the first attempts to reorganize the Earth's world as an engineering project. One by one, the decisions made by these true masters of the world are shaping the present and the future. Something must push them to borderline conclusions. They must fully realize their role, responsibility and mission. Then a series of actions, carried out independently of each other but in a single logic, can overnight reformat the entire system serving Leviathan. From the engineering point of view, there is nothing impossible in this, as long as the chosen path fits within the boundaries of physical laws, genetically prescribed by the Creator at the making of our Universe, in which we all live now.

Earth has more than enough resources for the prosperity of 10 bln people. We only need to give them a reasonable, engineering assessment and use them wisely.



4. Engineering Reconstruction

4.1. How Many People Can the Planet Accommodate?

Before having a vision of the engineering, which, by some means, have become the driving force and the highest value of civilization and can make the world a better place, it is necessary to make sure that there are enough resources for humanity to continue civilizational development. What is the margin of safety and what are the actual capacity limits of the planet and its biosphere? Will they be achieved in the 21st century? Or rather the rationalization of their use can significantly (by hundreds or even thousands of years) delay the moment of reaching the point of no return? Is everything that the capitalist pseudo-elites scare people with (the greenhouse effect, the carbon footprint, the impending shortage of food and energy, overpopulation) really that dangerous? Or are these only myths and horror stories, the cultivation of which pursues goals that are fundamentally different from those proclaimed? How to estimate the capacity of the biosphere from an engineering point of view? This will require only figures and facts.

4.1.1. Greenhouse Effect and Safe Carbon Capacity of the Earth's Atmosphere

The greenhouse effect on the planet is caused by the presence of polyatomic gases in the surface layer of the atmosphere. These gases are opaque to thermal radiation and include water vapor, carbon dioxide, methane, ozone, nitrogen oxide, freon and others.

Water vapor, of which there are 12.7 tln tons in the Earth's atmosphere, is the most active greenhouse gas in terms of its influence on the planet's rising temperature. Its contribution to the total greenhouse effect on Earth, reaching 32 °C, is 20.2 °C, compared to the 7.2 °C that CO₂ contributes [65].

The greenhouse effect on Earth now is, on average, up to 78 % due to water vapor and only up to 22 %, or 3.5 times less, due to carbon dioxide. Contributions from other gases, including methane, is negligible [66]. That being said, in terms of one ton of gas in the Earth's atmosphere, the greenhouse efficiency of a ton of CO₂ is only 1.5 times higher than the greenhouse effect from a ton of water vapor.

Without greenhouse gases, the average temperature on Earth would be about -18 °C, compared to today's average temperature of about +15 °C, meaning that all rivers and seas would permanently be frozen and there would be neither flora nor fauna on the planet. Therefore, the greenhouse effect is the greatest good. The life on Earth, most likely,

would not exist without it. Or the protozoa originated on an early hot planet would continue to exist somewhere in the unfrozen depths of the oceans.

Emissions of industrial water vapor, like that from cooling towers of nuclear power plants, are not so harmless because each ton of steam entering the surface layer of the atmosphere is equivalent in terms of the greenhouse effect to 0.67 tons of carbon dioxide. Therefore, the environmental friendliness of a nuclear power plant is an illusion not only because of problems with radiation but also due to climatic factors, since for every kilowatt-hour of electricity generated at a nuclear power plant, 3.6 kg of water vapor is released into the surface layer of the atmosphere. In particular, in 2015, Russian nuclear power plants emitted 730 mln tons of water vapor into the atmosphere. In terms of CO₂, that equals about 490 mln tons of carbon dioxide [65], which, as example, significantly exceeds greenhouse gas emissions by all Russian transport, including cars.

Additional sources of water vapor entering the planet's atmosphere from human activities (in bln tons per year): evaporation from waters used for domestic needs - 180, evaporation from industrial waters - 800, from river flows for irrigation - 5,400. In total, in CO₂ equivalent (from the standpoint of the global greenhouse effect), this amounts to more than 4 tln tons of carbon dioxide.

Considering that the greenhouse effect from a ton of water vapor in the atmosphere is only 1.5 times less than CO₂, the impact of anthropogenic activities on the water vapor circulation and its contribution to the greenhouse effect is 140 times (!) greater than the carbon coming from all industries on Earth, including transport.

Today, it is more important for humankind to optimize water consumption in everyday life, industry and especially agriculture to organize a successful fight against "global warming". It is more significant than, for example, at the behest of globalists, to redirect our efforts to "carbonic windmills" because the decarbonization program promoted by "deep power" pursues completely different goals, nourishing their obsession with global warming. But when globalists realize the importance of water vapor in the greenhouse effect, they would most likely propose a radical "solution" to "optimize" planetary processes in their demonic style: to roll the entire World Ocean into asphalt, since it is the main source of water vapor in the Earth's atmosphere.

The entire multimillion-year-old history of the life development on our planet evidences that carbon dioxide is not the main climate-forming factor. For example, 250-320 mln years ago, in the Carboniferous period, the concentration

of carbon dioxide was two times lower than it is now, but the average temperature was 10 °C higher [67]. Meanwhile, 150-200 mln years ago, the content of CO₂ was almost an order of magnitude higher than in 21st century - 0.3 %, and 400-600 mln years ago - even 0.6 % [68], although there was no global warming, on the contrary, almost the entire planet was covered with ice.

The total carbon dioxide in the Earth's atmosphere amounts by the time of work on the text to 3.03 tln tons, or about 0.038 % of the total mass of the planet's atmosphere. Of that, 550 bln tons annually dissolve in seawater and transform into living matter due to photosynthesis [69]. On average, all atmospheric CO₂ participates in the carbon planetary cycle every 5-6 years.

The creation of organic matter annually consumes about 300 bln tons of carbon dioxide (about 10 % of CO₂ in the atmosphere) [70]. Most carbon dioxide mass returns to the atmosphere and hydrosphere due to the oxidation of once-living organisms and their waste products.

The most significant amount of free carbon dioxide in the biosphere is in the ocean's upper layer - 140 tln tons, which is 46 times greater than in the atmosphere.

Due to the creation of organic matter in the Earth's biosphere, the carbon cycle is completely closed. Only an insignificant part of the total organic carbon absorbed by plants annually passes into the lithosphere and leaves this cycle.

Studies have shown that the current level of carbon dioxide in the Earth's atmosphere for effective photosynthesis is 2-3 times lower than the optimal one. The data on the optimal levels of CO₂ in commercial greenhouses is cited at levels of 0.1-0.12 % or more [67]. Based on this, we can conclude that there is a shortage of carbon dioxide in the Earth's biosphere from all living matter point of view (and not from a "human-globalist" - a very limited in biospheric knowledge - one of the billions of living organism species on the planet) by hundreds of billions, if not trillions, of tons.

An increase in CO₂ concentration in the atmosphere is caused not so much by industry and transport as by its return from sediments in the ocean and on land due to a raise in the average temperature on the planet. It boosts crop yields and promotes the growth of forests, meadow plants, fish, crustaceans, mollusks, algae and corals in the ocean.

Therefore, the global level of industrial CO₂ emissions in the 21st century (about 30 bln tons per year, or about 1 % of its content in the atmosphere) will affect the greenhouse effect at a maximum of 1 % of the previously mentioned 22 % carbon dioxide impact on the climate, for a total of a mere 0.22 %. This is significantly lower than the margin

of error in measuring the average temperature on the planet and the average CO₂ content in the atmosphere. An additional greenhouse effect will manifest only if this industrial carbon dioxide remains liberated instead of being bonded by green plants or green technologies in industrial regions or dissolved in the ocean.

Therefore, the recently vilified anthropogenic CO₂ is entirely safe for the biosphere and it is not just not excessive but does not even make up for the carbon deficiency in the Earth's atmosphere.

It is important to remember that the dry matter of any organism, not including the oxygen and hydrogen contained in all living cells, is about 60 % of carbon. Carbon is the main chemical element of life on Earth, including humans. The food chain for carbon begins precisely in the atmosphere, where it should be present in sufficient quantity from the viewpoint of the evolution of the living biosphere, not the dead technosphere created by human civilization or artificial intelligence, which does not need a biosphere at all.

4.1.2. World Energy Consumption

The term "world energy consumption" refers to the total energy consumed by our civilization. It includes all the energy obtained from all energy resources and used in all industrial and consumer sectors of the world economy. This measure of consumption is an essential indicator of a technogenic civilization's level of development in the productive-economic and sociopolitical fields.

The average solar energy density at the outer edge of the Earth's atmosphere is 1.366 kW/m². It has already been calculated that without this energy on the planet (if the Sun is "shut off"), the Earth's atmosphere would drop to -20 °C over a week and then to -73 °C over a year. After a few years, the temperature on Earth will drop to -240 °C and remain at this level [71].

The prevailing opinion is that over the whole new history, when the Earth's industry appeared everywhere and started to develop intensively, solar radiation was stable, with variations within a 0.2 % range. Such variations in the intensity of solar radiation will amount to only 2.732 W/m², which, with a cross-sectional area of Earth of 130 mln km² that includes the atmosphere, provides fluctuations in the power of external energy falling on the planet of 350 bln kW. This value exceeds 167 times the total rated capacity of all power plants worldwide, equal to 2.1 bln kW. With a population of 8 bln people at the beginning of 2023, this amounts to only 0.26 kW of electric power per one inhabitant of the planet.

We assume that the same fluctuations in the power of the planet's extrasolar energy supply from the technogenic civilization are acceptable in the future and will not lead to global environmental problems.

Moreover, the power of solar energy reaching Earth is unstable over time due to changes in the distance to our star (from 147 mln km in January to 152 mln km in July). Such fluctuations during a year can be up to 6.9 %, which is 34.5 times greater than the 0.2 % mentioned earlier, and amount to 12 tln kW. With this background, 2.1 bln human-made kilowatts of power plant capacities (less than 0.02 % compared to 12 tln solar kilowatts) do not have any significant impact, which should be apparent to any more or less competent independent expert. So, due to annual fluctuations in the power of solar energy, the temperature in some regions of our planet can reach 100 °C: from +40 °C in summer to -60 °C in winter. It is unlikely that anyone in this region will notice the human-made climate changes by 0.02 % towards warming, for example, up to +40.01 °C in summer and up to -59.99 °C in winter.

Besides, the luminosity of our star increases by 1 % every 110 mln years due to the accelerated combustion of hydrogen (the power of solar energy reaching Earth grows at the same time by 1.78 tln kW). Therefore, in 4–5 bln years, the Sun will go as far as turning into a red giant, expanding and simply swallowing Earth [72].

The capacity of the world energy consumption in the first part of the 21st century, considering the combustion of the nuclear power industry and hydrocarbons in various furnaces and internal combustion engines, is about 20 bln kW, or 2.5 kW for each inhabitant of the planet. Combined with an increase in power of energy consumption per capita to 5 kW (i.e., with annual per capita energy consumption of 43,800 kW·h), considering its environmental optimization the safe capacity of the terrestrial power industry is: 350 bln kW / 5 kW/person = 70 bln people of the planet.

From the above analysis it follows, with a future Earth's population of 10 bln people, the power capacity that is safe for the biosphere per one inhabitant of the planet will therefore be: 350 bln kW / 10 bln people = 35 kW/person.



This amount is 13.5 times higher than the current per capita power consumption of the entire terrestrial technogenic civilization. Being more precise: these 350 bln kW of power are not critical for the biosphere, since the energy threshold of security for it will be at least an order of magnitude higher.

4.1.3. Biologically Safe Capacity of the Biosphere for the Technogenic Human Population

According to the latest data, in the 21st century about a trillion species of living organisms currently populate the planet, of which we know less than 0.0001 %: animals, plants, fungi and microorganisms (microbes, viruses, bacteria, protozoa, etc.), whilst the non-microscopic species (visible to the naked eye) account for no more than a million species. All these living beings have been residing on planet Earth for millions and some for billions of years. In the course of evolution, everything here has evolved together, so everything in the Earth's biosphere is harmoniously arranged, there is nothing redundant, and there is no need to improve anything.

We do not need to fight microorganisms; we must learn how to coexist. We will lose any war declared on microbes because more than 10,000 species of bacteria, viruses, archaea and fungi live in our bodies. The human microbiome has an astounding number of inhabitants, about 100 tln bacterial cells. They constitute a highly complex human ecosystem and are the basis of the immune system, especially the intestinal microbiota, which consists mainly of soil microorganisms – they feed, water and even treat us. A person has much fewer own cells – about 40 tln, so there is a risk of harming them, since it is impossible to fight a single representative of unwanted viruses (for example, COVID-19) without disturbing the developed over millions of years symbiosis between trillions of species of useful microorganisms and the human body.

The medicine prescribed by the doctor may fix one thing while it breaks another. The treatment is not much important itself but the prevention of diseases by strengthening the immune system, which is our universal medicine. This requires healthy lifestyle, both physical and spiritual; proper and healthy nutrition, grown on fertile soil without chemical fertilizers and pesticides; living natural spring low-mineralized drinking water; clean air that is replete with phytoncides from medicinal plants and flowers.

Even if 100 bln people live and work on the planet, their biomass will be only 0.05 % of the Earth's biosphere biomass, which, for example, is less than the mass of all ants,

mosquitoes and flies (including their larvae). And this in no way will lead to global problems if, of course, humanity stops fighting nature and begins to coexist with it, as one of the biological species, according to the biospheric laws that have developed over billions of years of evolution.

4.2. Engineer Reforms: Engineering Epoch Technosphere 2.1

The engineering of the 21st century has enough resources and unprecedented technical capabilities for the positive transformation of the world created by previous generations of engineers. However, this will require radical transformations in the system of value orientations and practical goals of society. The reassessment can be carried out as a result of the approval of the corresponding political will, which is hardly realistic, taking into account the modern specifics of both political and economic goal-setting. Another option for initiating a reassessment is to launch powerful engineering projects through social and financial instruments, which by this time had been developed and practically implemented by engineers. Crowdfunding based on digital platforms can become such a system. At the same time, launched projects should cover the main areas of the economy and offer solutions aimed at a deep transformation of the basic sectors of the world economy.

Engineers could start the changes by redesigning four key industries: power, agriculture, transport, urbanism (residential, social and industrial infrastructure). The goal of the changes should be provision to the humankind of environmental, raw materials, food, energy, transport, infrastructure, demographic, social and other types of security as well as the harmonious spatial development of civilization on a global scale. A significant economic effect should be based on large volumes of creative work. This means that the desired projects must have a huge potential, be feasible and effective. A complex of such projects is designed to ensure a deep reform of civilization and its entry into the epoch Technosphere 2.1. What can it be and on what technologies its basement is possible?

4.2.1. Power Industry

Oil shale's total global biosphere reserves are estimated at 650 tln tons, and brown coals is estimated at 4.9 tln tons [72, 73]. The organic matter of oil shale is formed from the biomass of predominantly nonvascular algae (saproel components), to a lesser extent – from land plants (humic components) and partially – animal organisms.

The content of organic matter, including proto petroleum, in shales is on average 45 % varying from 10 % to 80 % in different fields.

The mass of organic matter in brown coals and oil shale can be estimated at 300 tln tons with an average specific heat of combustion of 33 MJ/kg (Qbdaf = 29–37 MJ/kg), or an average of 9.2 kW·h/kg. These reserves of oil shale and brown coals are sufficient to generate approximately 2.7×10^{18} kW·h of energy, of which 1.2×10^{18} kW·h is electricity, with an average efficiency factor of a coal-fired thermal power plant equal to 45 %. Then, with an average annual per capita energy consumption power of 5 kW/person (!), where 2.25 kW/person is electric energy and 2.75 kW/person is heat, oil shale reserves will provide 100 % of energy to the Earth's population of 10 bln people for 5,400 years (!).

Relict Solar Bioenergy (RSBE)

The energy stored in brown coals and oil shale is relict (ancient) solar energy created by living organisms that were on the planet 100–450 mln years ago. Therefore, oil shale and brown coals can be used not so much for generating electrical and thermal energy but for producing relict living humus. This being the basis of the fertility of any soil because such biohumus will have the same chemical composition as an ancient tree that took everything necessary for life from the relict soil.

It is proposed that we should not burn fossil fuels completely; instead, perhaps 50–75 % at most. The combustion waste from fossil fuel burn, including ash, slag, sludge, dust and flue gases, must be mixed with the unburnt 25–50 % of shale or brown coals, plus any raw organic materials, like grass, peat, sawdust, manure or household compostables. The resulting multicomponent mixture, in which organic and mineral raw materials are present, is finally processed into fertile humus in bioreactors using specially selected communities of aerobic and anaerobic soil microorganisms taken from the world Bank of fertile soils created in Belarus on the territory of the Unitsky's Farm Enterprise.

The resulting relict biohumus can be added to the soil at a level of 2–3 %, which, with this proportion, would make even the most barren desert sand fertile. Ideally, highly fertile soil could be created around the power plants. Gardens will grow on it. In this vision, grapes, apples and other agricultural products become the net positive "waste" of the operation of relict solar biopower plants.

This is easy to achieve, as more than 80 chemical elements that make up all terrestrial living organisms, including ancient plants, turned into coals and shales in prehistoric

times, and all of them again, through the restored relict soil, will give new life to new organisms in 100–450 mln years only.

Most prevalent in the 21st century traditional thermal power plants emit waste into the atmosphere, causing acid rains that kill all life in the vast areas it touches. At the same time, the substances contained in these rains, for example sulfur, belongs to macroelements and is vital for all living organisms. So, the daily amount of sulfur an adult requires is 4–5 g (our body contains about 100 g of it), and it should enter the body of a plant, animal or human not in the form of acid rain but in the form of organic compounds with food.

Excess heat from power plants (about 55 %) can be sent to the greenhouses or be converted into the cold in hot countries and sent to cool orangeries. Furthermore, carbon dioxide will not be emitted into the atmosphere. It will be delivered to greenhouses and orangeries instead where this carbon will be utilized by plants in food carbohydrates, proteins, fats, vitamins and other living matter in the form of thousands of various organic compounds, which include in their composition the entire periodic table, the main share in which, by mass, falls precisely on carbon. It should be noted that greenhouses plants will absorb atmospheric CO₂, produce food and release additional oxygen for people nearby to breathe.

Furthermore, deep processing of some coals and shales will be carried out at relict solar biopower plants to obtain from them not only fertile humus but also synthetic fuels as well as a wide range of chemical products (aromatic hydrocarbons, oxygen and nitrogen compounds, alicyclic alcohols that have hydrogen-donating properties, etc.) and chemical elements, including gold (its content in shale is up to 40 g/t), elements of the platinum group, tungsten, molybdenum, rare, rare earth and other metals.

For example, some Russian coals contain, in grams per ton of coal: yttrium – 254, scandium – 96, dysprosium – 384, gadolinium – 335, samarium – 211, lanthanum – 46, cerium – 89, neodymium – 806, which is more than 2 kg of rare earth elements per ton of fossil fuels. Therefore, Russia's entire demand for rare earth metals (about 10,000 t/year) can be covered by processing only 5 mln tons of such coals. The entire world demand (about 200,000 t/year) can be covered by processing 100 mln tons, less than 1 % of coals and shales planned for use in such power plants.

Coals (shales) and the products of their combustion – flue gases, dust, ash, sludge, slag – will be used as raw materials for obtaining chemical products at biopower plants located in industrial clusters. Such technologies in the 21st century have already been created for a long time.



At the same time, the lower the energy value of the used coals and shales (the higher their ash content), the more efficient and productive they will become from the standpoint of the production of fertile humus and a wide variety of chemical elements, products and substances at biopower plants. Therefore, relict solar biopower plants operating on brown coals and oil shale will meet the future demand for these products of humankind on Earth for millennia to come.

By-Product of Relic Solar Bioenergy – Soil Fertility Improvement

The RSBE technology is completely biospheric, meaning environmentally friendly and waste-free. A power industry such as this will not kill living creatures; on the contrary, it will create and foster new lives with natural, not nature-like technologies.

About 450 tln tons of living humus with a moisture content of 50–60 % can be obtained from 300 tln tons of organic matter of shales. When about up to 10 % of humus (this is its

average content in rich chernozems) is introduced into the upper fertile soil layer with a thickness of 30–40 cm, or approximately 30,000 t/km², it will be enough to transform 15 bln km² of area into chernozem agricultural lands. That amount exceeds the area of the earth's surface by approximately 100 times and the area of the entire surface of Earth by 29 times.

Thus, the terrestrial relict biosphere power industry could transform the planet's entire land into a blooming garden, planted on the most fertile and ideal soil for life, the rich chernozem. Even if the layer of chernozem reaches a meter or higher, this will not be hard to achieve. Such bioenergy will become actually free for humankind since the "waste" it produces – fertile humus, which will cost more than oil on the market and will pay off the production of electric and thermal energy.

The RSBE technology can produce more than 1.5 tons of humus from a ton of brown coal. One ton of humus would enable the growth of about a ton of organic food. Therefore, the annual production of 15–20 bln tons of brown

coal and shale, which will be only 2–3 times as the level of their production by the end of the first quarter of the 21st century, will not only provide energy to 10 bln people (!) at the rate of 5 kW/person but nourish them with healthy and wholesome, even curative, food. Moreover, this will stop the desertification of the planet and annually ramp up the production of nutrient-depleted and desert soils to the chernozem level on an area of more than 30 mln ha, which, for reference, exceeds the area of the most European countries.

The principal oil shale reserves are concentrated in the United States, accounting for more than 400 tln tons, from which more than 300 tln tons of humus can be produced (along with the generation of electrical and thermal energy). These reserves alone are enough to provide humanity with energy for thousands of years to come and turn the entire planet into a blooming garden several dozen times over with a layer of chernozem thicker than that currently existing in Ukraine. The cost of American shales as an energy resource and raw materials for the production of biohumus can be estimated at 3,000 tln USD at a minimum cost of 100 USD per ton, or 30,000 tln USD at 1,000 USD per ton.

Food Solar Bioenergy (FSBE)

Biofuels are various combustible products derived from raw plant materials, the main advantage of which is their renewability and that they require solar energy readily supplied to Earth. Therefore, using biofuels in transport, industry and power will not change the existing natural energy balance of the planet.

For example, with a sugar beet yield of 100 t/ha, grown on highly fertile soil enriched with biohumus, and sugar content of 18 %, the root crops planted on 1 ha of land can bring 10 tons of pure alcohol. Alcohol is an environmentally friendly fuel that is practically equal in its characteristics to natural gas and hydrogen. The additional upsides of alcohol-based energy are that it is less explosive, easy to store and use and more readily available.

The remaining 90 tons of raw beets from each hectare will be used for animal feed and humus, returning to the soil as organic fertilizer. Additional humus will not be required to restore the nutrients taken by beets from the soil that were used to obtain alcohol, since the plants take carbon, oxygen and hydrogen, forming part of alcohol, not from the soil humus but from the air (carbon dioxide) and soil water (for example, 100 tons of root crops contain about 70 tons of water).

To obtain 1 bln tons of alcohol annually (approximately the same amount of motor gasoline produced in the world

in the 21st century) it would require 1 mln km² of sown land. This area is 21 times smaller than the planet's deserts, occupying 21 mln km², not including the polar deserts of Antarctica and the Arctic. By restoring the fertility only in these territories, humankind will be able to fill its need for environmentally friendly hydrocarbon fuel for millennia and provide food through the additional production of humus to billions of people and animals.

The 2 bln tons of dry residual organic waste created annually in alcohol production could become animal feed and biohumus in biopower plants. That's why living matter will return to the soil where, for example, sugar beets were grown, not only restoring but enriching the fecundity of this farmland, thanks to shales. This process is the real green solar bioenergy, not environmentally unsafe windmills and solar panels that produce only energy but nothing more and require a lot of nonrenewable resources for their production and ensuing disposal.

If 1 tln USD is invested annually in relict and food solar bioenergy, it would be about the same as in oil production and refining in the 21st century. This investment would provide energy to all of humanity. In addition, this would enable additional annual vegetation of an area of 330,000 km², equal to the size of a country like Vietnam. Note that such a biospheric-driven power industry could increase the total biomass of plants on the planet because they would grow where today's deserts are. Such a plan would not only increase the utilization of anthropogenic CO₂ by plants but also provide the additional production of food for humans and animals. Additionally, it would increase the production of oxygen by the biosphere, which is necessary for 10 bln air-breathing people and compensation for its withdrawal from the atmosphere by terrestrial industry, including relict bioenergy.

4.2.2. Agriculture

The total dry biomass of the biosphere is about 24 tln tons, of which over a trillion tons is carbon [74]. At the same time, the primary biomass on the planet is green land plants, while all other living organisms (animals and microorganisms on land and in the ocean as well as aquatic plants) have a total mass of only 38–46 bln tons (less than 2 %), counting the underground biomass located at depths of up to 5 km.

Contemporary humankind is about 350 mln tons of biomass in live weight (about 45 kg/person, including children), or about 100 mln tons in terms of dry biomass (about 13 kg/person), which is about 0.004 % in comparison with the entire biomass of Earth.

The large biomass and variety of terrestrial living organisms are accounted for by humus, a complex organic matter due to which any soil becomes fertile. In the most fertile soils, chernozems, up to 10–15 % is humus. The basis for producing organic food for humans is fertile soil.

An average person (considering all age groups) consumes about 700 kg of food per year, or about 150 kg of dry matter. Because of metabolism, each person excretes approximately the same amount of waste into the environment, primarily through their digestive system. Suppose this waste, converted into humus, is brought back into the same soil where the crops were grown. In that case, the natural circulation of living matter, disturbed in the 21st century by the humankind, will be restored.

Chaotic development of engineering in the field of agriculture made food to grow in one place, and waste to be generated in another, thousands of kilometers away. At the same time, the billions of tons of nutrients taken from fertile soil do not return in exact quantities. Mainly just three chemical elements (nitrogen, potassium, phosphorus) return to the ground, although plants, during their growth, take more than 80 elements from it. Moreover, simple and soluble industrial chemical fertilizers feed the soil of farmland instead of complex organic insoluble humates created by life, as it was during the previous hundreds of millions of years of the life evolution and the Earth's biosphere.

Agricultural Production

To make the substances, taken from the soil during the cultivation of agricultural products, returning, it is necessary to combine the zones of their production and consumption spatially. Therefore, agriculture must be integrated into residential infrastructure or, conversely, residential infrastructure must be integrated into agricultural production. How to do it?

The roofs of houses (attic) can exist as glass greenhouses and as orangeries in hot climate countries. The basement could be used for growing mushrooms, breeding poultry, fish and seafood, both marine and freshwater, as well as other products for consumption. At the same time, an enclosed agricultural zone can be maintained commonly by a gardener and an agronomist hired by each household.

Microgreens and green food for the residents of these houses can be produced in greenhouses and orangeries, including equipped with humusoponic vertical farms. According to this technology, the root system of the plants receives a nutrient-rich solution, and shoots grow from planted

seeds within 5–7 days. This technology is natural, in contrast to the conventional nature-like hydroponics based on chemical mineral substances, as evolutionarily plants feed on organic humus.

Humus – insoluble salts of humic acids stored in the soil – is converted into a soluble form by a community of thousands of species of aerobic and anaerobic soil microorganisms directly in the root system of plants. Therefore, agricultural farms integrated with a residential area can use humusoponics – according to this technology, plants feed on liquid humus, in which insoluble salts of humic acids have pre-converted into a dissolved form. By the time of publishing this text such experiments have been successfully implemented at the Unitsky's Farm Enterprise.

Microgreens grown on humusoponics are natural organic foods, originally rich in easily digestible nutrients and vitamins. Their cultivation technology has no industrial fertilizers or chemicals like pesticides, herbicides and GMOs. For example, in comparison with dry food for animals (mixed fodder, meadow hay) humusoponic fodder from wheat germs is better absorbed, more energy-intensive and contains 2–3 times more proteins and fats. At the same time, it exceeds dry food tenfold in terms of its content of carbohydrates, sugar and vitamins. It is also much healthier and more efficient than fresh grass and hay. Unlike other forage eaten outside the pasture, this feed comes in the living form at the peak of its growth, preserving all the vitamins and digestive enzymes that animals need, especially in winter.

Another fundamental difference: the animal eats the aboveground part and the remnants of seeds with starch and the root, rich in sugars and proteins. Meanwhile, diverse organic waste materials can become a substrate: straws, press cake and even specially prepared wood chips, which microorganisms and plant roots convert, through fermentation, into easily digestible food. The result is balanced, complete and stable in its composition and quality fodder, ensuring the herbivorous animals get all the essential nutrients they need.

Regardless of the season and natural and climatic conditions (drought, torrential rains, heat and frosts), humusoponic installations will provide animals and people with fresh green food all year round, which is especially important in case of vitamin deficiency in winter.

Growing a ton of green forage requires about 2 tons of water, while the conventional field method requires 400 tons, i.e., 200 times greater. Moreover, for traditional cattle feed harvesting it takes about a hectare of land to feed one head of livestock. In contrast, the proposed

technology of all-year-round vertical humusoponic farms, arranged, for example, in the semibasements of buildings and structures, requires about 1 m² of floor space, which is 10,000 times less. This comparison excludes (in 10,000 times larger natural areas) the mechanical tilling, fertilization, sowing, harvesting, transportation, drying, etc.

Year-round cultivation of agricultural products in greenhouses under protected ground conditions towards the end of the first quarter of the 21st century, for example, in the Netherlands, yields an average of up to 50 kg/m² per year. To sustain a family of five with fruits, vegetables, berries and herbs, up to 100 m² of area is enough. If greenhouses occupy the roofs, then each house could feed the family living there with plant food. In this case, such a house does not destroy natural soil, as it will be moved to the roof from under the foundation of the house, enriched with humus and become greener and more productive.

Meat and Biohumus Production

Let us consider the production of organic meat using the example of cattle since cows allegedly cause much more damage to the Earth's ecology than, for example, cars and airplanes combined. Experts made this conclusion from the Food and Agricultural Organization of the United Nations (FAO) [75]. According to the FAO, about 1.5 bln cows live on Earth in the 21st century, emitting 18 % of supposedly all 100 % of greenhouse gases, which exceeds the emissions of all transport on the planet.

Actually, this 18 % comes from 22 % of the greenhouse gases – carbon dioxide. That is, their effect is only $0.18 \times 22 \% = 4 \%$, since the leading greenhouse gases – water vapor – for some reason were not considered, although the significance of H₂O in creating the greenhouse effect in the Earth's atmosphere, as justified above, is 3.5 times higher than CO₂.

A cow eats about 20 tons of green fodder annually and produces roughly 20 tons of urine and manure. Hence, all 1.5 bln cows in the world will require about 30 bln tons of animal feed; they will provide 30 bln tons of manure, or in terms of dry matter – 3.5 bln tons, or 1/55 of the biomass produced by the biosphere.

The annually dying on the planet biomass, that same grass, regardless of whether cows ate it or not, would still require processing by the biosphere during one season into humus by the same microorganisms as in the stomachs of cows, with the release of the same associated gases, primarily methane and CO₂, and in the exact amounts.

So, cows in no way change the biosphere processes and do not harm Live Nature because the biosphere is utterly

indifferent to where this organic matter, with the absorption of oxygen and the release of methane and CO₂, is processed, whether in the soil or the digestive system of an animal. At the same time, cows speed up processing organic matter into humus since this living biofactory turns dry grass into almost ready-made biohumus within a day. In the soil, these processes take several months.

Each cow produces several items, among which the surplus value of its biospheric waste – manure and urine as organic raw materials to produce humus – is commensurate with the cost of milk and meat it produces. One cow can annually supply 100 kg of nitrogen, 50 kg of potassium and 140 kg of phosphorus as part of natural organic fertilizer with almost 100 % assimilation in soil [76]. In addition to replacing nutrients taken out by plants from the ground, all types of manure increase the proportion of humus in the soil and restore the fertile layer of any land.

Therefore, the vilification of organic beef in the works of some researchers, including under the auspices of the UN, is just a commissioned work to transfer human nutrition to synthetic meat in the interests of the producers of this dangerous food.

As mentioned earlier, 30 bln tons of manure, converted annually into fertile humus, for example, in relict solar biopower plants, will cost about 10 tln USD on the world market. However, these 30 bln tons of biohumus will make it possible to cultivate many organic agricultural products (primarily in linear cities) to feed more than 20 bln people – without using chemical fertilizers, pesticides and GMOs. This solution will solve the problem of hunger on our planet.

A car, on the other hand, does not produce anything useful except for transport services, while its industrial waste (exhaust gases, wear products of tires and asphalt, deicing salts, etc.) contains more than 100 carcinogens that can poison all life on the planet in territories exceeding, for example, an area of Great Britain several tenfold. Therefore, comparing a cow and a car from the standpoint of danger to the biospheric habitat is incorrect and sinful.

4.2.3. Transport

It has been repeatedly said that by the end of the first quarter of the 21st century transport became one of the main sources of environmental pollution of the planet. A significant part of the best plots of land on the planet is today paved over and "buried" under railway sleepers; it is equal to the area of five Great Britain [77]. The fertile soil adjacent to the roads is degraded on a more extensive territory by order of magnitude. Due to imperfect transport, about 1.5 mln people

die on the roads every year, including postaccident deaths in hospitals, and hundreds of millions, if not billions, of large and small animals; more than 10 mln people get into accidents, are injured, become disabled and are crippled.

If nothing changes, by the end of the 21st century, more than 100 mln people may die on roads, while about a billion will become disabled and crippled. Electric cars – a fashionable trend in transportation – will not necessarily save lives. On the contrary, they will likely kill and maim people on the roads.

Meanwhile, the travel speeds remain limited due to the technical imperfection of the transport systems that are widespread everywhere. Optimization of the global transport industry becomes a vital task. It can only be solved by engineering means. If the humanity starts with the recognition that engineering is the highest value, then constructors and designers should solve not only an improvement challenge for the existing transport but also a creation one for the optimal transport. To do this, it is necessary to understand the essence of such technological invention and bring its configuration to the verge of effectiveness in terms of the physics laws.

The bases of traction calculations for the movement of any vehicle are four main forces operating upon transport while in motion:

- 1) aerodynamic resistance;
- 2) wheel rolling resistance (or other propulsion unit resistance);
- 3) ascending grade resistance on the upward route;
- 4) inertial forces.

Moreover, the first two forces are the major ones. The force of an automobile wheel rolling resistance mainly depends on the deformation of the tire and the road in the contact zone. However, already at a speed of 60–70 km/h the force of air resistance exceeds any other, and at a speed over 80–100 km/h it surpasses them all combined.

In the formula for calculating the air resistance force, only the speed is taken in the square. Thus, if the speed is doubled, the air resistance will be increased four times, if the speed is tripled, the resistance will be increased nine times, and so on. The energy consumption to overcome this resistance will also grow proportionally, which becomes to be extremely significant and in fact makes it impractical for an ordinary car or train to travel at a speed over 120–150 km/h. Taking this into account, it turns out the improvement of high-speed ground transport is impossible without knowledge about aerodynamics.

Which item has the best wind shape? Everyone knows the answer to this question. A falling drop of water has the most acceptable shape (at the time of its formation, since then the drop is deformed during its fall) from the aerodynamic point of view. That is, a rounded front surface and a smoothly tapering long back.

Aerodynamic drag coefficient C_x is an experimental value. Numerically, it is equal to the force of air resistance in newtons that occurs at a flow velocity of 1 m/s per 1 m² of frontal area. It is customary to take a flat plate as a reference unit, for which $C_x = 1$. So, a drop of water has $C_x = 0.04$. Now imagine a car of this shape. Nonsense, isn't it? Not only such a thing on wheels looks somewhat cartoonish, this car will not be very convenient to use for its intended purpose. Therefore, designers are forced to find a compromise between the aerodynamics of the car and the convenience of its use. Constant attempts to reduce the coefficient of air resistance have led to the fact that for some cars $C_x = 0.25–0.28$. High-speed cars can boast of $C_x = 0.2$. However, these indicators are still insufficient for cars to drive at a speed over 150 km/h in normal mode without enormous fuel consumption.

Any gas, including air, consists of molecules. They are in a constant motion and interaction with each other. And so-called van der Waals forces occur – the forces of mutual molecular attraction that prevent their displacement relative to each other. Some of them start to be attracted to the rest stronger. With an increase in the chaotic molecular motion, the effectiveness of one air layer impact on another also increases as well as its viscosity. Such a process occurs due to a rise in air temperature, and this can be caused both by direct heating from the sun or indirectly – from the air friction on any surface or simply its layers among themselves. In order to understand how this affects the car, just try to wave your hand with an open palm. If the stroke is slow, then nothing happens, but if it is stronger, the palm clearly perceives some resistance. This is just one component.

When air is directed over some stationary surface (for example, the body of a car), van der Waals forces contribute the nearest molecular layer sticking to it. This "stuck" layer slows down the next one. And so on, layer by layer, and the faster the air molecules move, the farther they are from a stationary surface. In the end, their speed is equalized with the speed of the main air flow. A layer in which particles move slowly is called a boundary layer, and it appears on any surface. The greater the value of the surface energy of the vehicle coating material, the stronger its surface interacts with the surrounding air and the more energy must be expended to overcome these forces. Now, based on the above,

we can say that air resistance is not just wind hitting the windshield. This process has much more components.

Frontal resistance is up to 60 % of all losses. When moving, the vehicle compresses the air flow on it and expends the effort to push the air molecules apart. The result is a zone of high pressure. The most striking example of this effect can be observed in the subway while the train is approaching the station: the train, like a huge piston, squeezes a huge amount of air out of the tunnel, and at the very beginning of the platform anyone can feel the power of this flow.

Further, the air flows around the surface of the vehicle body, during which the air jets are separated with the formation of turbulences. The final stall of the air flow is stated at the car's rear and creates a zone of low pressure. The resistance in the front and a suction effect at the car's rear constitute a serious counteracting to the movement. This fact obliges designers and constructors to look for ways of body shaping that would cause the least disturbance of the air environment when the air flow vanishes.

The utmost influence on the overall aerodynamics of a high-speed train, as example, is exerted by the forebody. During experiments in a wind tunnel, it is concluded that for better aerodynamics, the forebody of a locomotive should be low, wide and should not have sharp corners. In this case, there is no airflow separation, which has a very beneficial effect on streamlining.

From the aerodynamic point of view, the side surfaces of the car, which has a small length compared to the train, influence the creation of a vortex-free flow most of all. But they also should not be rounded too much, as this will lead to an increase in the cross section of the body (midship) and worsen its aerodynamics.

The rear of the vehicle also has a significant impact on the streamlining coefficient. The explanation is simple. Here the air flow breaks off and forms backwash. In order to avoid this, the back part tend to be made with a teardrop shape to minimize the effect of stall.

There is one more thing that significantly, at least twice, worsens the aerodynamic qualities of ground vehicles moving at a high speed – the airfoil effect.

The airfoil effect is the same air cushion used in the transport of the same name, but the air injection is formed not by special devices (for example, a propeller) but a dynamic air flow. Thus, the body of the car, when driving at a high speed, creates lifting force not only by reducing the pressure above the roof surface but also by increasing the pressure under the lower part of the body, which is fraught with separation from the roadway when driving.

The manifestation of the airfoil effect can be regularly observed during the "24 Hours of Le Mans" motor racing.

To combat the airfoil effect, designers must increase downforce with the help of rear air spoiler, diffusers and fairings. Each aerodynamic element increases the midsection of the transport, which negatively affects the overall aerodynamic quality. It is a vicious circle.

Public transport has also picked up on the trend of reducing aerodynamic drag, making it faster and more efficient. Mallard steam locomotive No. 4468, built in Great Britain in 1938, had a maximum design speed of 203 km/h and was used in regular passenger service until the early 1960s.

Japanese Shinkansen (Jap. 新幹線 – new highway) high-speed rail network has been transporting passengers since 1964. The first trains reached speeds of 210 km/h in some sections. Later, it became possible to increase the speed up to 360 km/h. However, such high speeds are the exception, not the rule. These railway trains continue to experience the airfoil effect, which decreases the aerodynamic performance at least twice, and require a huge amount of energy for high-speed movement.

The impact of the airfoil effect is especially significant when using a monorail suspension scheme, for example, in the Transrapid train, which has the highest value of the aerodynamic drag coefficient C_x . This indicator at a high speed cannot be lower than 0.4 due to the presence of a so-called "skirt" enclosing the carrier beam and the velocity gradient in the air gap between the "skirt" and the fixed beam (not only from the top of the beam but also from its sides and the bottom). The minimum possible value of C_x for a module that is placed near the roadway (as a car) is 0.2 due to the airfoil effect created by the stationary roadway. The smallest value of C_x (0.05 and below) is for a virtual wingless drop-shaped module located above the ground at a height of 10 m or more. For a bus-sized vehicle (length, width and height) with a speed of 140 m/s (504 km/h), in the first case, the power of the aerodynamic drag will be more than 4,000 kW (the power of the main diesel locomotive), in the second case – 2,000 kW (the power of three tank engines), in the third – 500 kW (engine power of a high-speed passenger car).

As you can see, due to its configuration, which implies movement in close proximity to any surface (the airfoil can be not only the roadway but also the surface of the earth and the water), not a single mode of transport is able to get rid of the airfoil effect. For this reason, high-speed traffic for all existing types of land transport is either difficult or impossible. That is why airplanes are used for high-speed

traffic – self-supporting vehicles that do not need a track structure, which are also expensive, inefficient and causing severe damage to nature.

It is possible to remove the airfoil effect by raising the vehicle above the ground. This, of course, does not entail a creation of one more obviously inefficient aircraft. Besides that, there are options.

So, an ordinary overpass raised above the ground is very material-intensive, expensive and, in addition, has a continuous roadbed. Therefore, even there the airfoil effect is not eliminated. However, this can be avoided by removing the continuous roadbed and leaving only narrow strips for the wheel movement. However, if the track structure is made continuous in length, without expansion joints, then the carrying capacity of the overpass can be doubled. To exclude compression (for example, in hot weather) and loss of stability, the supporting structure of the overpass can be stretched in the longitudinal direction, i.e., it can be made as a prestressed one. Such variant of systems exists, in particular, in cableways, but there is no rail, and the wheel moves at a low speed (and with large energy losses) along the cable, which quickly wears out and becomes unusable.

That is why the main technological element in an optimized transport is a rail, in the core of which there is a bundle of bearing reinforcement (strings) stretched in the longitudinal direction. Such a rail allows not only to remove the airfoil effect but also to increase the bearing capacity of the supports on which it is mounted by eight times, since the supports are not cantilevered as in traditional bridges but are fixed at the ends – from the bottom (foundation) and from the top (track structure). This means that supports can be dozens of times cheaper, since the weight load from a light overpass (as an engineering bonus) will be an order of magnitude less than in traditional beam bridges. This solution seems to be optimal from both the minimizing aerodynamic resistance and reducing capital costs for road construction points of view, compared to all known alternatives for a track structure laying – an earthen embankment, a tunnel, a conventional beam overpass.

The described road configuration makes it possible to improve aerodynamics by using a rail car on steel wheels. Its drag coefficient has been reduced to 0.05 (for example, the most expensive and fastest Bugatti car has this coefficient of 0.38), which approaches the theoretical limit of 0.04. These results were obtained experimentally, by means of multiple blowdowns in a wind tunnel, and are patented.

It remained to solve the problem of overcoming the rolling resistance of the wheel, which consumes about 1/10

of the energy during high-speed movement (9/10 goes to aerodynamics). This solution was borrowed from railway transport, which uses the most efficient system for supporting the rolling stock on the track structure: "steel wheel – steel rail", where the efficiency factor is 99.8 %, since a force of 2 kg can move a cart weighing a ton on a horizontal rail track. Losses in this case are by an order of magnitude less, and at high speeds they are even two orders of magnitude less than that of the "pneumatic tire – asphalt concrete canvas" system. And far less compared to other systems – air and magnetic cushion, not least because of the presence of the latter's airfoil effect.

The described engineering goal-setting allows to create an optimal transport system. Its main elements:

- 1) continuous prestressed string rail overpass;
- 2) unmanned rail vehicles on steel wheels, called uPods, are highly aerodynamic, equipped with an anti-derailment system and having an intelligent security, control, power supply and communication system.

The creators of all transport systems spread on Earth in the 21st century relied on the laws of nature, but their actions were spontaneous in terms of goal-setting. As far as it is known, none of them set themselves a large-scale task. They were designing, for example, the best sports car or the most advanced fifth generation fighter jet. No one tried to create a fundamentally new system, or rather a transport and infrastructure complex, including more than a dozen systems and subsystems (rolling stock, track structure, power supply system, automated control and communication system, logistic infrastructure, etc.), optimized from the standpoint of physics (mechanics, aerodynamics, energy, strength of materials, tribology, etc.), which could become the basis for transportation on a global scale. Namely, the scale in the assessment of transport is a decisive factor. One car is probably good. But 2 bln cars predicted by 2035 is a disaster. One plane is great. But hundreds of thousands are so bad that the governments of some countries are even forced to introduce an environmental tax. Therefore, the main requirement for ideal transport is the ability to transport many people and goods quickly, efficiently, comfortably and affordably (spatially and financially) without harming the environment, primarily living, of which people are a part (but not an artificial intelligence, as example).

Engineering optimization, possible in a situation where engineering becomes a value, allows to create not only the most efficient but also the safest and most environmentally friendly transport.



If during the 21st century all transport will become overpass and string rail then land users on the planet will be returned territories equal to six Republics of Belarus, previously occupied solely by motor roads [77]. The liberated lands can be made fertile again. It will require about 25 bln tons of living humus, allowing enriched soil to produce about 1 bln tons of agricultural products annually (about 100 kg/person). In addition, the greenery will enable oxygen production and capture atmospheric carbon dioxide at about a ton of CO₂ from a hectare daily [78].

Building a network with its overpass prestressed track structure on the second level will reduce pointed earthwork by more than 100 times compared to laying the same roads in a linear embankment. In addition, savings on the road network of 25 mln km will amount to more than 1 tln tons of soil, and it should not have to be brought from the tens of kilometers far away the quarries as well as there will not be any need to dig them. Consequently, the natural landscape and biogeocenosis will not suffer any significant damage, and land reclamation will be unnecessary in the construction zones as well as in the ground and the sand mines. This part is crucial when passing the route on permafrost soils that cannot withstand the additional load from the embankment weight and higher temperature loads in summer.

There will be no embankments and dugouts here, sometimes reaching 10 m or more, like the modern roads and railways have. Such structures will not disrupt the migration of domestic and wild animals, will not depress natural biodiversity and will not hinder the movement of agricultural and other equipment. Furthermore, there will be no swampy or deserted vast territories along the second level tracks, especially on rough terrains, since each roadbed is a low-pressure earth dam that interferes with surface and groundwater movement. The soil in it should compact only 10 % compared to the natural occurrence. There will be no need for water release structures, bridges, overpasses or multi-level interchanges.

In the 21st century, introduction of new technologies into transport can save about 100 mln people from death in car accidents and about a billion people from injuries and traumas. At the same time, overpass prestressed tracks will not kill trillions of large and small animals as they will not trap under the wheels since it is the second level transport. The wars continuously going on the planet claim fewer lives and maim less people as well as animals – large and small, domestic and wild.

In addition, land users of the planet will get back more than 1 mln km² of soils that are “rolled up” in asphalt

and “buried” under rail sleepers today. Significantly larger land areas on all continents will not continue to degrade due to the proximity to motor roads and railways.

The unmanned vehicles on steel wheels moving above the ground are characterized by unprecedented efficiency. So, compared to the Tesla electric car with pneumatic tires, their efficiency is 5-7 times higher. This indicator is also due to the absence of an airfoil effect. This aspect alone improves the aerodynamic drag of uPods by 2-2.5 times [77].

The described advantages are especially noticeable for large-scale communications. For example, about 10 mln high-speed uPods will run on the routes of linear cities with an average capacity of 40 passengers. That equals 3-5 passengers for family cars to 150-250 passengers for trains. *(For comparison, by the moment of publishing this text, the world's car fleet alone is greater in 150 times, which is approximately 1.5 bln units.)*

Steel wheels, unique aerodynamics and the absence of an airfoil effect reduce the power of resistance to movement at a speed of 500 km/h by an average of 2,500 kW per one vehicle [77], which will save up to 25 bln kW for the mentioned car fleet. With a utilization rate of 0.75 (18 h of operation per day), these parameters will save about 40 bln tons of fuel annually, worth about 40 tln USD. In addition, approximately 120 bln tons of oxygen will not be burned out of the planet's atmosphere yearly, including that in thermal power plants that generate energy for electric transport. Plus, almost 200 bln tons of exhaust and flue gases will not enter the atmosphere.

This is the real, and not declarative, saving of resources in the 21st century (and only in relation to the high-speed component of the global transport and communications industry):

- steel – savings of 250 bln tons;
- reinforced concrete – savings of 3 tln tons;
- exhaustible mineral raw materials – savings of more than 3 tln tons;
- soil (including fertile soil) – savings of 1 tln tons;
- fuel – annual savings of 40 bln tons;
- atmospheric oxygen – annual savings of 120 bln tons;
- environmental resource – the absence of annual emissions into the biosphere of about 400 bln tons of solid and gaseous technogenic wastes, including gases from exhaust and flues.

The cost of saved resources at about 1,000 tln USD. No less valuable will be the billions of people's and animals'

lives saved in the 21st century and about 1 mln km² of territory returned to the true landowner, the biosphere. It is also essential that it will not contain about 400 bln tons of fuel combustion products and technogenic pollution.

4.24. Residential and Industrial Infrastructure

Both the early 21st century cities layout and the logistics in them as well as buildings and structures do not respond to the requirements of a safe, sustainable and comfortable living for residents. Cities on the planet were built and developed spontaneously. First, hundreds and thousands of years ago, footpaths were made between certain dwellings by walking and then paved with cobblestone, along which horse-drawn city transport began to move. Then asphalt was laid on the cobblestones for the cars to drive. Later, skyscrapers were built around the asphalt. This was how megacities emerged where the life had become impossible.

The historically formed infrastructure of habitation was built not for people but for cars, primarily for road transport, which today counts more than a billion passenger cars alone. This includes traffic jams, smog, noise pollution, dirty air, soil saturated with hundreds of carcinogens, exhaust gases, anti-icing agents and tire and asphalt wear products. The streets, backyards, surface, overland, underground garages and car parks are packed with millions of vehicles.

Cities on the planet have occupied vast territories, and what is more, they use the best lands. These lands have been withdrawn from biospheric life cycles because buildings, structures, city roads and infrastructure occupy them. For example, China's world's largest city, Chongqing (82,400 km²), is practically equal in area to a country like Austria (83,800 km²).

Linear cities harmoniously blend with the environment of any natural and climatic zone on the planet can become an alternative to the 21st century megacities [79, 80]. They will not take away the fertile land for construction, moreover, they create more. The cities will have everything they need: clean energy, organic food and artesian spring water. In the 21st century such cities will help deserts disappear from the planet, transforming Earth into blooming garden where all humanity will live and work safely and comfortably.

Placing linear cities at least 10 m above the current ocean level is more reasonable. If it rises in the future, in hundreds of years, through a natural cyclical global warming or warming caused by human activity, the ocean will not flood these settlements.

The linear city will be made of pedestrian clusters connected by the urban electric second level communicator

moving at a speed up to 150 km/h as the safest, most energy-efficient and environmentally friendly type of passenger and cargo transportation [81].

The transport and communication corridor of about 100 m wide will be passing through the linear city or parallel to it – the high-speed air routes of string transport (speed up to 500–600 km/h), hypervelocity routes located in forevacuum tunnels (speed up to 1,200–1,500 km/h) and cargo systems [77]. To ensure comfortable movement, in which centrifugal accelerations should be below 1 m/s², the radii of curves on vertical and horizontal routes at a speed of 500–600 km/h should be at least 20–25 km, and for 1,200–1,500 km/h – at least 120–150 km. Hence, the linear city can be winding, but high-speed routes must be as straight as possible.

With an average population density in a linear city of 2,000 people/km, to accommodate 10 bln people, the total length of cities, built along the communication network and combined with relict solar biopower plants, power transmission and communication lines, would be 5 mln km. Then the network of linear cities will occupy an area of about 5 mln km², or 1/27 of the Earth's land, excluding the continent of Antarctica. The remaining 26/27 of land can be allocated for national parks, reserves, wildlife sanctuaries and reservations with sparing land tenure systems [82].

The area of deserts on the planet, excluding the polar deserts of Antarctica and the Arctic, is four times greater [83]. Therefore, if the deserts were made green and fertile and linear cities were built only there, 40 bln people would be able to live in them, and they would be supplied with everything they need: housing, food, drinking water, energy, transport, work, rest and recreation. It would be easier and cheaper to do this than, after having finally exhausted, polluted and ruined our native planet, to fly to a distant, cold and alien Mars to lead a wretched existence in spacesuits, without organic food and fresh air and water.

Linear cities will occupy the land nominally, since gardens will grow on the roofs of all buildings and constructions (in greenhouses and orangeries). Thus, natural biogeocenoses and biospheric ecosystems will be created – even in the place of deserts and permafrost.

The total length of the network, counting the transverse lines and the second level roads entering protected natural areas and natural resource deposits, will then amount to approximately 10 mln km (for comparison, the total length of the world network of all types of roads is currently more than 60 mln km) [84].

Near the residential clusters, along or across the linear city, there will be infrastructural clusters with other functions:

scientific, educational, industrial, sports, shopping, entertainment, recreational and more. To improve the logistics and maintenance of production facilities, including the relict solar biopower plants with a large volume of freight traffic of raw materials and humus, infrastructure clusters may be located outside the residential area – in the area of the transport and communication corridor. The required volume of transportation through the cargo component of the global network is about 10 bln tons of shale and brown coal per year and about the same amount of fertile humus.

In the linear city, the average speed of public urban transport, rail electric vehicles on steel wheels, will be 60–80 km/h and more, that is, for example, higher than in Moscow tube. With no traffic obstacles, such as intersections and pedestrian crossings, cars, trams, buses, snow or sand drifts or puddles on the roadway, it will be the safest and by order of magnitude faster urban public transport in the world. For example, the fastest urban transport of the first quarter of the 21st century is in Berlin, where its average speed is 6.5 km/h (for comparison: in Washington – only 2.8 km/h) [85].

The overpass transport with a prestressed sagging track structure can become the most energy-efficient type of urban road out of all theoretically possible ones, since it automatically recovers energy when moving from station to station. When leaving the station, the uPod, moving downhill, accelerates to the rated speed (for example, 100 km/h in the middle of a span) only due to gravity and without using engine. In the second half of the way, moving upward, cabin is decelerated by gravity without using brakes.

In such operation system, similar to the pendulum swings, the potential energy is automatically converted into kinetic energy and vice versa under the laws of physics and not with the help of mechanical recuperates, which, as a rule, have a low efficiency factor. Energy is needed here only to overcome a steel wheel's aerodynamic drag and rolling resistance, which is about 5–7 times less than is required when the traditional urban modes of transport, like buses, trams and trains, move along a horizontal track. Therefore, to perform similar transportation work, the network of string urban routes located at the second level will require 5–7 times less energy than an ordinary urban transport network at the first level of the same length and capacity.



The track structure of transport systems of linear cities can be designed in such a way that electrical and information networks will be embedded into it, providing electricity and communication for both the clusters and the linear city as a whole with the entire infrastructure: social and cultural, shopping and entertainment, scientific and industrial and others.

Each cluster will have one or several relict solar bio-power plants with a total capacity of 5,000–10,000 kW (depending on the number of cluster residents) located outside the residential area and producing up to 50,000 tons of fertile humus over a year. This would enable, for example, annually transforming up to 1 km² of the desert into fertile land such as chernozem. Therefore, in 50 years of operation, the worldwide linear city will be able to increase soil fertility to the level of rich chernozem on the entire Earth's land, including mountains and deserts.

The cluster, with an area of 1–2 km², with dimensions of about 1–1.5 km, is planned to be constructed as a pedestrian urban-type settlement. It will comfortably accommodate from 2,000–3,000 people (based on 500 m²/person, or 25 ares for an average family of five) to 7,000–10,000 people (200 m²/person, or 10 ares per family). With minor changes, the cluster can be erected on the sea shelf or open sea, if the buildings and structures are buoyant.

The dimensions of the clusters are conditioned upon the need to connect their centers with each other by the urban overpass tracks of a sagging type with one span without supporting towers. It is known, that frequent stops for urban transport less than 1 km apart significantly reduce the average travel speed and lead to an increase in trip duration. And in a linear city on spans longer than 1.5 km, the track structure will sag excessively under its weight and the weight of the rolling stock, requiring passenger stations to be located at height of 50 m or more. Therefore, the dimensions of the cluster in plain view and the length of spans of 1–1.5 km are ideal from the viewpoint of pedestrian and urban transport logistics as well as technical and economic indicators.

The residential area will appear as blocks, separated by a green strip 100–200 m wide, with common spaces for the cluster residents and guests: leisure and sports areas, public buildings, sports stadiums, a health center, a medical station, shops, cafes, workshops, a kindergarten, a school and other amenities.

In the center of the cluster, there will be a dominant building with a passenger station on one of the floors or the roof, within walking distance. Reaching it from any

point of the cluster takes less than 10 min. In the center of the green strip at the height of more than 10 m, there will be a track structure that is visually light and delicate, even casting no shadow, which, with the same capacity, will be at least 10 times cheaper than a traditional underground metro.

Silently moving along air rails, there will be the rolling stock of high-speed sky metro – unmanned rail electric vehicles on steel wheels, which are at least three times more power-efficient, i.e., greener than a traditional electric car. The height of the safe movement of suspended uPods at the lowest point of the track, in the middle of the sagging span, namely in the interval between adjacent clusters, will be no less than 6 m to their bottom.

Residential buildings will be united as a single architectural and functional system, like a “horizontal skyscraper” multi-apartment, or a high-rise building lying on its side. The “skyscraper’s” dimensions, including its length, can vary over a wide range, from 100 m to 1 km. Each house would need a living area of 100–300 m² to accommodate an average family of five. The homes will have two or three floors: a semibasement, a living floor and an attic.

For thermal insulation, the buildings are more expedient to carry out frame with panels made of vacuum glass – the thermal insulation properties of such panels with a thickness of 20 mm are equivalent to a brick wall with a thickness of 1.5 m. If necessary, the panels could be transformed into electronic screens to display images. The primary construction material is sand, which is enough on the planet for trillions of such “skyscrapers”.

In terms of energy efficiency, each “horizontal skyscraper” in the cluster will be designed as a “energy-plus house”, according to the European classification. When a house like this includes all the utility equipment (solar panels, collectors, heat pumps and recuperates), it generates more energy than it consumes.

Conventional roads in the cluster will be green, made of aerated concrete with grass, combined with pedestrian and bicycle paths and suitable for light electric vehicles. In addition, provisions will exist for heavier traditional vehicles, such as ambulances, fire engines and farming equipment. The same goes for dirt roads with grass embankments between the houses to access each household plot.

Therefore, each cluster is a self-sufficient urban-type settlement, although according to its living arrangement it is more likely to belong to rural settlements. It will be provided with everything of its own production, including food, water, energy, transport. And it guarantees food, energy,

environmental, infrastructural, social and other security of the linear city even during pandemics, lockdowns or other natural and human-made disasters.

Optimization of urban planning constructions, buildings, structures and infrastructure (“linear skyscrapers”, roads on the first and second levels, adjacent territories and common land plots, engineering networks, landscaping, etc.) will reduce the cost of housing and living in a linear city by 2–3 times that of conventional urban development while improving the quality of the living environment and the standard of living of urban residents.

4.3. Rules for Life of the New Engineering World

A fundamentally new infrastructure of settlement, living, working and recreation of people in linear cities, dovetailed with terrestrial nature, without violating its local and global biogeocenoses that have developed over millions of years of evolution, enables us to look differently at societies historically formed on the planet that are part of the structure of our modern technogenic human civilization.

After inventing the first machine as the servant, human socially mutated over the generations and became the invention's servant and eventually its slave.

We cannot imagine life in the 21st century without a smartphone and a car, and we care about them more than about our health. For example, the creation and implementation of the iPhone and MacBook technologies were more important to Steve Jobs than the functioning of his pancreas, from cancer of which he died at the age of 56.

After all, we do not put our smartphone in the microwave for a night because we realize it will quickly fail to function, although we can put it next to our pillow, closer to our brain. And we can even build a house under a high-voltage power line and easily cross it dozens of times daily.

We are afraid of high voltage in the socket. Still, we do not attach importance to getting electric shocks from a door-knob because we are dressed and booted in an electrified insulator. However, our ancestors walked barefoot and had the electrical potential of Earth. People are not bothered by sparks flying when we comb our hair, which speaks of a high, about 100,000 V, electrical voltage around our head. However, we know that our nervous system and brain are super-complex low-voltage networks that exchange weak electrical impulses sensitive to external electric and electromagnetic fields.

We are afraid to walk up to the verge of the roof of a 20-story building but not scared of the collision with an oncoming car at a speed of 70 km/h, although hitting

the ground after falling from a height of 80 m will happen at the same relative rate.

We, humans, keep moving further away from the Live Nature that gave birth to us into the inanimate world of machines, devices and artificial intelligence. We are happy when our five-year-old child is confident with a computer but are not upset when they think that bread grows on trees, like apples, and sausage is grown in seedbeds, like radishes.

Four sectoral industrial technologies drive the technocratic development vector of our civilization – agriculture (food sector), transport and communications (communications sector), power industry (industrial opportunities), the infrastructure of living, production and work (habitat). It is going down a blind alley due to the imperfection of these outdated and almost ancient technologies that do not meet the civilizational requirements even of today, let alone the future. Under the guise of global warming, deindustrialization, decarbonization and other global problems of our time, there is an attempt to zero out the civilizational settings and break the existing industrial civilization code.

It is well known that the solution to any complex issues should always be sought at a higher level of understanding.

The leading causes of the global problems of our time are the activities of humankind on the platform of the mind. For these difficulties to become a thing of the past, every human and humanity needs to rise to a new macrolevel, the level of reason.

Only our ability to reason distinguishes us from animals on a system level. Animals have intelligence, but they cannot form reason. The mind is responsible for food, procreation and other bodily needs required for survival. Therefore, even the coronavirus is smart enough not to set a goal of annihilating its habitat, the human body, where it settles.

Our ability to reason is responsible for spirituality, self-knowledge, self-development, human feelings and emotions, morality, ethics, art, culture, improving relations with others and the surrounding nature and other spiritual values, including engineering as a form of practically oriented art.

Only the presence of reason makes a human a social person. Concepts such as “society”, “sociality” and “socialization” have very similar meanings. All these concepts can be replaced by two simple and familiar to everyone words: human relations.

The presence of reason enables us to consciously improve and develop our relationships with other people, the surrounding nature and with the entire Universe as a whole. It manifests itself in every person as spirituality and conscience. According to all spiritual, philosophical

and religious teachings, everyone should improve and develop themselves, building elevated relationships at all levels. For this, nature gave reason to humans.

While possessing both mind and reason, human has become binary: he is both a social person and, simultaneously, an individual one.

Individual means intelligent, while social means reasonable. The more reasoning a person does, the higher the spirituality is and the better the human builds relationships with others, the surrounding world and nature in all its manifestations.

With the development of industrial technologies in a consumer society, created in the era of capitalism and oriented just on getting profits, aimed at satisfying bodily and mental needs and pleasures. At the same time, we pay less attention to improving the inner people's world, the level and quality of their relations with one another and the outside world. And the less humaneness remains in people, the more inhumane offenses they commit and the more chaos they bring to our world, destroying Live Nature.

The technogenic civilization created by people is a civilization of knowledgeable but very unreasonable people. Modern humans have begun to value individual comfort much more than interpersonal relationships. Such people are, by contemporary medicine standards, "mentally unsound".

The wider the gap a person has between mind and reason, the worse it turns out for the individual and the spiritual environment of the habitat – society. And, vice versa, the more conscious the relationships between people in the community are, the faster they and society succeed in all areas of their activities with significantly less effort and resources. This point is where the rationality of everyone should manifest in the realization that their main personal benefit is the spiritual development and the development of social and interpersonal relations not only with other people but with the surrounding world.

The actual progress of our technogenic civilization, built on engineering and scientific technologies and discoveries, should consist not so much in the development and improvement of industrial achievements as in the progress



of humaneness in people making up our terrestrial and precisely human civilization and not any other (dolphins, ants, bees, etc.). The time has come to build a society consisting not so much of intelligent techno-consumers as of socially reasonable people, for which they need to learn how to create and make social inventions and discoveries, along with technical ones. Technogenic civilization must be replaced by engineering civilization.

Humaneness is a cultural, moral and community-social state of an individual, the development of their mind and acquisition of full-fledged morality and ethics of interpersonal relations, conscious responsibility and a holistic understanding of real life on Earth, in the biosphere of which there are billions of species of living beings inhabiting a shared planet that is but a speck of dust in the infinite Universe.

Humaneness and spirituality reveal the fullness of each person's nature, unique abilities and talents. By developing these qualities in oneself, one begins to feel the fullness and wealth of the Earth's life – one's own and that of society created together with the likes of oneself.

The completeness of morality is when it is not only our life that we want to make happy, versatile and high-quality but the lives of our relatives and friends, based on the logic of the "Six handshakes rule", out of love for them, relying not on self-interest but on higher order values.

Conscious responsibility is when we take personal responsibility not only for our life and health (physical, spiritual and moral) but for the health and life of our loved ones, humanity and the whole planet and do not shift this responsibility onto others.

The integrity of understanding is when we consciously develop our reason towards understanding how the natural, not virtual and digital, world around us works and functions and the meaning of each life and its purpose.

The deeper and wider a human reveals one's individuality and hidden talents, the wealthier, better and more interesting one's relationships with others will become. The divine principle of unity in diversity put in by nature is possible only with the disclosure of people's essence, which will only enhance and increase their enjoyment of life and relationships with one another.

The more femininity in women and masculine qualities in men, the more attractive they will become to each other and the more powerful and stable their family unions will be. Here lies the divine wisdom so that life should not degenerate but develop eternally from the simple to more perfect, sublime and higher quality. Specifically, sociality and interpersonal relations enabled several thousand primitive people to create

their first engineering technologies and, over several thousand years of evolution of engineering creativity, to develop into a modern technogenic mega-society – multibillion humanity. However, in this process a gap appeared between morality and engineering, which must be eliminated through an appeal to reason and giving it a system-forming status.

Reason, like life itself, has an anti-entropic nature, meaning that it always strives to increase and arrange knowledge, to understand the essence of the Universe and in its highest manifestation to comprehend the divinity of Live Nature and to restore the material and mental relations and connections with it that the techno-consumer has lost during the development of industrial technologies.

Human, as an entropic matter, is doomed to decay. Human's intellect and ability to reason is an anti-entropic tool, the purpose of which is to elevate the nonmaterial component of the personality – spirituality. Human develops the individual and, accordingly, collective reason only when, relying on personal talents and experience, brings benefits not so much to individual targets as to those that are common; this is the essence of the concept of human humaneness.

Based on all existing religions, the goal of anyone's life is to be able to reveal all the best in themselves and to be reunited with the Universe that created them. Therefore, the main goal of the leadership of each state is to help people living there to achieve that. Such is the social and spiritual responsibility to society.

People on the platform of the mind become individualists and morally degraded due to the wrong priorities and goals of the consumer society imposed upon them by the media working for the highly secretive interests of the global businesses that created them.

In the current reference frame, economic growth and GDP are determinants for all states, not the development of a country's citizens as spiritual people. The actual priorities should be different. There is a well-known saying: do not put the cart before the horse. Material well-being is the cart, while the development of human qualities in a person is the horse of civilizational progress. Correct and safe onward movement is when the horse is harnessed to the cart, not vice versa.

If people switch from an economic frame of reference – from a consumer society – to a social coordinate system that stimulates the development of their human qualities and reason, then our civilization, realizing itself not as technogenic but as engineering one (i.e., based not on technology but on creative potential inherent in the essence of engineering activity) will be developing much faster, more confidently and more sustainably.

Our priority should be living in a society of humanity, spirituality and morality, not the desire to become a slave of the rapidly created dead, soulless and impersonal artificial intelligence, which will control our bodies and souls based on primitive binary and virtual mathematical codes. There is no need for rose-colored glasses to see why this is happening; it is to obtain enormous profits for those who promote this same vector of civilizational development.

Where the bow of the ship points, the ship will sail along that course. Therefore, the state should focus on developing morality, spirituality and humanity in people. Then it will be assessed upon indications featuring the level and quality of human relations. Accordingly, we can focus all public institutions on improving these indicators.

Today, heads of state are like principals of trendy schools who assess the situation only by technical improvements in their educational institutions. Notably, the educational process itself at school needs to be improved. So, what are children taught? And are they taught anything necessary, meaningful and valuable? What is the use of the fact that the school is equipped with the latest technology and looks good on the outside when the pupils there, oblivious of their lessons, ferociously fight with one another and class on class and can even kill each other in the heat of the moment? We see it happening now everywhere on our planet, divided, like a patchwork quilt, between 245 states and dependent territories.

The level of development of people's reason, morality and responsibility determines the quality of their relationship. Therefore, a state should not be assessed by the GDP growth rate, as it is common in the age of full-fledged capitalism, but by such factors as the crime level, the scale corruption; the number of depression, stress, conflicts; cases of domestic violence, mental and other diseases, divorces, abortions, suicides; the number of unemployed and homeless people; the number of single parent or incomplete families, children raised by stepparents and older adults left without the support of their children.

Among the positive factors are birth rate and the level of education and morality; the number of registered family unions and orderly families, gold and diamond weddings; the number of healthy (physically, morally and spiritually) people leading a healthy and moral lifestyle; the duration and quality of life of each person and society as a whole; attitude towards friends and family and the outside world; the amount of preserved and augmented biosphere resources.

The main task of the education system will be fostering children's high qualities and pursuit of moral and spiritual development. Cinema, television and mass media should

not advertise "chewing gum and popcorn" for the prosperity of yet another business but spread something more elevated and significant: morality and ethics, co-creation and a culture of communication aimed at strengthening the family and encouraging people to show their best human qualities in all structures of society, starting at the family and rising to the state and civilization level.

In the 21st century, society is focused on profit, which develops individualism and the "take it" vector in people. In contrast, commitment to the ideology of morality and humanity extends in people the will to share something meaningful and worthy with others. Resetting society to the moral vector of development will entail economic growth because where people care for each other's welfare, security and stability will rise, labor efficiency and productivity will increase while living and operating costs and expenses will drop.

The criterion of efficiency and the level of civilization of society and an individual will not be profit but the common good, which will turn the techno-consumer humanity into engineering, socio-technocratic one. Labor will become the central element of creation and creativity rather than a mechanism for a person to survive in society and civilization on the planet.

Such a development course can bring the world community during the 21st century to harmony and prosperity. Without reducing population and without deindustrialization, as exactly the engineering technologies increased the quality and a standard of life: from the primitive existence of caveman to the current civilizational level, with the simultaneous growth of a small population of two-legged and upright walking semi-animal individuals to billions of reasoned and spiritual individuals.

By the end of the first quarter of the 21st century human civilization has entered a regime of turbulence and instability due to the rapid development of engineering technologies and against the backdrop of underdeveloped moral and ideological platforms. Attempts to create new totalitarian sociopolitical and economic-technocratic global international systems will inevitably arise on the ruins of old philosophies and ideologies. To prevent these attempts, one needs to be aware of their symptoms.

These destructive systems block and suppress the development of morality and the manifestation of humanity in people; they do not allow us to find, reveal and realize the amplitude of our human qualities. Social and educational stratification and restriction of knowledge limit the development of human reasoning, including reducing it to piecemeal knowledge. For example, some children are educated more about one subject or another but not on the amplitude

of knowledge about the surrounding world's diversity and that everything is connected. Moreover, the education system is perverted: children learn to become consumers and lay people rather than social personalities and creators.

Deterioration of morality begins in childhood and is implemented by focusing people's consciousness on bodily needs. However, spiritual needs mainly come down to entertainment and virtual games, most of them being trivial and primitive "shooters" in which you need to wipe out as much and many of something and someone as possible or destroy and kill in the most sophisticated manner. From early childhood, this forms a person's individualism and consumer attitude to life, each other and the entire Universe as a whole, leading ultimately to the disintegration of individuals, societies and countries, to environmental and manufactured disasters, economic and sociopolitical crises.

The destruction of traditional morals, which have formed in society over millennia, occurs, among other things, through the damage of the institution of the traditional family as well as through the deprivation of parental rights and committing children to the care of a depersonalized and soulless state or third-party or alien and strange individuals and organizations.

People's sense of responsibility gets blocked through the stratification of society, through the systemic subordination of people to the hastily created impersonal, asexual and unfeeling artificial intelligence as well as through restriction of social rights and freedoms of the human person, which has a nature-given living body, life-creating gender and living soul.

The planetary consumer society, a contemporary technogenic civilization, created over the last 200 years of capitalism (starting with the George Stephenson railway), now resembles reasonless mold in a Petri dish devouring limited resources, polluting the space around it and inevitably perishing.

Responsibility can develop in every person only in the space of freedom. The less genuine freedom people have, for instance, the more the application of protective masks on their faces, the more vaccines and microchips they receive, the more often they hide in lockdowns, the less responsible and free they become. Step by step, they turn into cyborgs, digitalized bioconvergers.

A hindrance to the development of every individuality is also the one-size-fits-all approach to assessing the usefulness of their work for society. For example, this was the case in the late Soviet Union – the same income level for all employees, regardless of the volume or existence of the profit they may bring.

Another formidable barrier to discovering the talents inherent in each person is all types of stratification of society, with the absence of individual means of social mobility.

For artificial intelligence not to turn humanity into an obedient herd of zombified enslaved people, a social and moral transformation of our civilization's technogenic vector of development is necessary, which translates into the progress of human relations, morality, ethics and humanity in people. And all this must exist spiritually for the Earth's society to become a civilization of reasonable people.

It is necessary to start such a civilizational reboot with specific steps: with the construction of the first targeted projects on a fundamentally new planetary eco-infrastructure, such as the string rail second level transport, linear ecocities at the first level and relict solar ecobio-power plants, whose industrial waste will be fertile humus and, accordingly, apples and grapes.

Proximity to the earth in a linear city would enable one to return to the origins – to Live Nature, whose part one forms and from which one becomes distant, having believed in the idol of scientific and technological progress.

At birth, we receive a body, the only thing at our disposal until the end of our days. Therefore, we must love our body so that it should serve us as long as possible. Food is the primary raw material for constructing cells, organs, systems and the whole organism. A lifestyle that provides bodily contact with nature is also important. All this is achievable with the organization of settlement in linear cities. Here it will become possible:

1) to walk barefoot on the healing morning dew every day and get up at the crack of dawn;

2) not to fear for the lives of one's children playing on the grass, not asphalt – they will not get run over because there are no cars;

3) to eat only natural organic food, which is healing and gives us health, well-being, endurance, high efficiency and longevity. Such natural food strengthens the immune system and prolongs our life up to 100 years or more, and it is irreplaceable by any of the most innovative and expensive biologically active dietary supplements, medicines, vaccines, vaccinations and procedures;

4) to breathe freely clean life-giving air, replete with phytoncides of healing field and forest flowers, herbs and trees;

5) to drink living spring (artesian) water, adequately sourced from the required deep aquifer within one's own or neighboring residential cluster without deterioration of its properties and quality;

6) to have one's favorite occupation in one's house or next to it, in one's own or a neighboring cluster, and not waste hours of precious spare time on uncomfortable, unsafe and not free of charge transport to get to work and back home every day. Walking to work will become the norm; based on physiology, walking at least 10,000 daily steps is advisable to invigorate the whole body. Such health-promoting physical treatment is beneficial at any age and has practically no contraindications;

7) to communicate with Live Nature and strengthen the body and spirit with productive physical activities. Regular activity is indispensable for our body, consisting of many moving elements – 850 muscles, 208 bones and 360 joints. Such daily practical physical activity on one's land, not in the gym, is vital for us, above all for the lymphatic system, which is the body's internal environment and is the basis of our immunity and health. Lymph consists of intercellular fluid and is the "gullet", "water pipe" and "sewerage" for every cell of our body; there are about 40 tln of them. This liquid does not have a heart of its own; therefore, the constant contraction of every one of our muscles is necessary for circulation through the lymphatic capillaries without the formation of zones of stagnation in all of the above moving elements of the human body and the diseases it causes, including cancer;

8) to get their primary life profession for each resident of a linear city – a happy person, which means he will become wealthy by creating in themselves the most outstanding human values: health (physical, spiritual and moral), longevity and soul profusion.

Clusters of linear cities will become the primary platform for the self-organization of communities for survival in today's fierce global competition, with a decrease in the role and importance of state borders as some socio-economic regulators.

Psychologically, a person continually strives to find support and mutual understanding among a community of people close to them in spirit and way of life. It is not enough to feel oneself just a member of society and a citizen of one's country. A modern person, tired of constant pressure from the authorities, politicians, businesses and advertising, vitally needs a kind of safety valve: understanding and solidarity, involvement without reaping benefits and gaining profits, self-fulfillment, spiritual and moral guidelines. The common culture and language are also significant: the mother tongue, through which the experience and knowledge of previous generations, culture and social

reference points transmit; and the communicatory (non-native) language, which is spoken by and between billions of people.

Such social needs – sociocultural ties, shared values, religion, traditions, art, ethnic and interethnic contacts, etc. – are satisfied precisely in small groups with similar interests. Consequently, such self-governing communities of various types, manifesting themselves in multiple respects (spiritual, religious, socio-economic, ethnic, organizational, managerial, communicative, political, educational, historical, ecological, etc.), can be created in clusters of linear cities.

At the same time, the development of science, culture and education, small and medium businesses, tourism and the service sector, intellectual and spiritual growth, upbringing of children, communicating with nature, growing organic food for oneself and members of one's family and other areas of academic, spiritual and physical activity will become the main work for many residents of linear cities.

Such work will be more exciting and significant for any society, including humanity in general. Thus, people will receive much higher wages than a coal miner, lathe operator, welder, steelworker or truck driver in a consumer society. Therefore, unemployment and poverty will become a thing of the past when the bulk of humanity moves from the concrete-asphalt jungles of megacities, torn from nature and life, to pedestrian linear cities, harmoniously blended with Live Nature.

An innovative strategy for transitioning local (cluster) societies of techno-consumers to a new state – an engineering socio-technogenic community – will prevail here. Such a readjustment of the long-term development vector of the Earth's human civilization assumes the conversion of military-industrial complexes and the creation of a new planetary eco-infrastructure – residential, transport, production (including agricultural), energy and information. As a result, it will become possible to use the social resources of the territories, the spiritual and intellectual potential of each person, energy- and resource-saving technologies, in particular, through the transition from the global export of resources and raw materials to the eco-production of goods and services (from the very same raw materials) in the clusters of linear cities – backed by our strength, interregional interaction and the human dimension in ecology.

4.4. Engineering Space Exploration

The reassessment of the engineering status and its inclusion into the context of the humankind moral life is

intended to provide conditions for the rationalization of civilization. In other words, such reassessment should create the initial necessary prerequisites for a rational arrangement of the human world. It also sets a new goal-setting horizon, in which civilization should no longer be considered as only an Earth's civilization but also as noospheric, take cosmic scales. The new approach directly follows the global significance of technology as a factor in civilizational development as well as from the global nature of the transformative possibilities of engineering. Moreover, when considering the prospects for transforming the people's lifestyle on Earth, inevitably conclude about the expediency of space exploration for industrial purposes.

The terrestrial technosphere occupies the same ecological niche as the biosphere: machines, mechanisms, technical devices are located in the thickness of the earth, water, air and actively exchange matter, energy and information with them. Environmental problems have already become acute in the last quarter of the 20th century because the technosphere in terms of its power supply, i.e., ability to transform the environment, has come close to the biosphere as a whole. For example, the biosphere reproduces 230 bln tons of dry organic matter per year, which, in terms of fuel, is only an order of magnitude greater than the annual energy consumption of all the equipment at the disposal of the Earth's civilization. And the volume of soil, ore and other types of raw materials transported and processed by machinery has come close to the volume of production of organic matter by the biosphere.

All technological resources are finite and nonrenewable due to the lack of circulation of substances, energy and information in the human-made technosphere. The main reason is that it does not have microscopic equivalent robots working at the atomic and molecular levels, such as microorganisms in the Earth's biosphere. If they were present, they could close local trophic industrial chains. The waste from engineering technologies, without any additional transportation and additional costs of energy and other resources, would become raw materials for other engineering technologies, and industrial (as well as biospheric) resources would become renewable.

Thus, the Earth's industry will continue to exist until it converts all the resources it needs into industrial waste thrown into the biosphere. And it does not matter whether the resources run out or the pollution destroys the biosphere because, in all these scenarios, any technogenic civilization will forego its future on its home planet. It will inevitably fade away and then die.

There is only one cardinal way out of this situation: it is necessary to provide the technosphere with an ecological niche outside the biosphere. This will ensure the preservation and development of the biosphere according to the laws and directions that have been formed over billions of years of evolution as well as the harmonious interaction of the people's community (as biological objects) with the biosphere.

There is no such ecological niche for the technosphere on Earth. But it exists in space, where for most technological processes there are ideal conditions: weightlessness, deep vacuum, ultrahigh and cryogenic temperatures, unlimited raw materials, energy and space resources, etc.

Thus, we reach the conclusion about the need of space industrialization, if in future the Earth's civilization continue the technological path of development. Humanity does not have much time for large-scale cosmic exploration – even with a reasonable reorganization of people's lifestyle on Earth. Technocratic oppression will be continued, although it has been optimized, which means further though slower but still degradation of the biosphere. Moving production into space not only solves this problem but also opens new vistas for engineering.

The entire terrestrial industry of the 21st century exists in the planetary technological environment, which is based on the specific gravity value (gravitational acceleration is 9.81 m/s² on average) and an air environment under the average pressure of 760 mm Hg, containing on average 21 % of very active oxidizing agent – oxygen. Gravity does not allow the creation of alloys and composites from materials with different densities – they are getting delaminated by the gravity forces. Many technological operations cannot be performed in the air, so they require vacuum systems. Moreover, obtaining 1 m³ of deep vacuum in terrestrial conditions is currently more expensive than extracting a ton of oil.

When the molten steel is poured out of the blast furnace, it burns and smokes. Thus, the process of metal oxidation with air oxygen takes place, as a result of which the metal loses its qualities [86, 87].

When obtaining medicines and other highly purified substances without impurities, ideal conditions are required, so the workshops for their production have a multi-circuit air purification system. However, this does not always help – even the most sterile air contains millions of tiny dust particles and thousands of microorganisms.

Earth's solar power generation industry does not work at night, in rain and cloudy weather, and the surface of solar panels should be constantly cleaned of dust and dirt.

We can continue to list the disadvantages of the planetary technological environment – there are thousands of them, including the limited material and spatial as well as energy and information resources.

The cosmic technological environment has many advantages. Weightlessness is the first one. If gravity is needed, it can be artificially created: any, arbitrarily large object (for example, planet Earth) can be spun around an imaginary axis without the use of thrust bearings since it is in space in zero gravity. The second advantage is deep vacuum and ultra-purity (including the absence of gases, air and microorganisms) extending to infinity. Thirdly, solar power plants (slender, light because they are weightless) in high orbits will work around the clock and year-round, they do not need to be cleaned of dust and dirt. Only one question remains – how to deliver all the necessary equipment into orbit and then how to transport space products back to Earth?

The geocosmic cargo flow determines the leading role of the industrial space exploration. In order to solve the problem of antagonism between the technosphere and the biosphere, which cannot be solved within Earth, it is necessary to establish production in space and the delivery of a sufficient amount of products to the planet. In the 21st century and in future, the annual individual consumption of industrial products should be commensurate with the ergonomics of a person, and above all, with his or her body weight. So, for 10 bln people that is at least 100 mln tons per year of space products or at least 10 kg per resident of the planet. In this regard, geocosmic transport (GCT) has a key role to play.

To create and optimize GCT, which can ensure the industrial exploration of space and the transition from Earth's to space civilization, a fundamentally different approach is needed in comparison to ground transport.

The fact is we are on a planet in a very deep gravitational pit, to get out of which we can either by rising into the infinity or flying out with the first cosmic velocity, equal to 7,919 m/s of the zero altitudes. And not vertically up but passing over to a low circular orbit, i.e., parallel to the surface of Earth. Therefore, each ton of cargo delivered to orbit must be supplied with a minimum of 8,700 kW·h of energy, which, for example, corresponds to the kinetic energy of a train about 20 km in length and more than 80,000 tons in weight, rushing at a speed of 100 km/h (the rocket system spends tens of times more energy on this work due to the low overall efficiency factor of the system). The traditional ground transport does not need so much energy –

it moves from point A to point B horizontally along the bottom of the "pit", i.e., over the surface of the planet.

Extremely high energy expenditures during the space industrialization impose a few serious restrictions on GCT:

- its efficiency factor should be close to 100 %, since even a relatively small release of energy into the environment, i.e., into the atmosphere through which cargo should be transported to orbit, will lead to catastrophic environmental problems during the operation of GCT;
- it is necessary to use the most environmentally friendly energy – electric – as the reference energy for GCT.

In addition to solving environmental problems, an increase in the efficiency of GCT will reduce the net cost of delivering cargo to orbit, which is inversely proportional to the efficiency factor of the transportation system (similar to any ground mode of transport). Currently widely used rockets as a transport for all these requirements do not fit categorically.

In fact, launch vehicles are extremely inefficient and causes the largest damage to the environment. If we consider all the flight and preflight costs and energy losses, then the efficiency factor of the rocket is less than 1 %, which is an order of magnitude worse than that of an archaic steam locomotive. In addition, it has long been calculated that only 80 launches per year of heavy Space Shuttle rockets can destroy the planet's ozone layer. The maximum permissible productivity of the entire world rocket and space complex by the end of the first quarter of the 21st century is less than 1,000 tons of cargo per year (only 0.1 g/year per one inhabitant of the planet), which, from the transport point of view, is at the productivity level of one earthly cart with a pair of strong horses. With the fabulously high transportation cost, the delivery of each ton of cargo into orbit costs about 10 mln USD.

There are various alternatives to rockets. A space elevator, a space tram, an electromagnetic accelerator, etc. If we consider this list from the proposed GCT requirements point of view, then to the greatest extent, only one engineering solution presented back in the 20th century corresponds to them – the General Planetary Vehicle (GPV), developed by the engineer Anatoli Unitsky [1, 77, 81, 88, 89].

The GPV is a ring located along the Earth's equator (or parallel to the equator), consisting of separate segments united by two longitudinal channels isolated from the external environment, in which vacuum is maintained. Inside the channels there are two linear (ribbon) rotor-flywheels, covering the planet and held by a system of electromagnets mounted on the principle of magnetic levitation, which

are the rotors of a giant electric motor capable of operating in generator mode.

The ring is located on a specially equipped overpass encircling the planet and running on land as well as on water (on special underwater pontoons). With the help of an external energy source, one of the linear rotors located inside the ring accelerates along the channel and, accordingly, spins around the planet to a speed exceeding the first cosmic velocity. Thanks to centrifugal force, each linear meter of the rotor first (when reaching the first cosmic velocity) balances its weight and then tends to rise up, providing lift force.

In the initial state, the ring is fixed to the overpass along its entire length. After the clamps are released, each linear meter of the GPV begins to rise upward relative to the center of the planet, i.e., increase its radius and, accordingly, its length. The design of linear ring objects (vacuum channel housings, linear electric motors, belt rotors) allows to increase their length by 1.57 % for every 100 km of ascent above the Earth's surface. After leaving the dense layers of the atmosphere, the rotor is transferred to the generator mode, and the generated electricity is used to accelerate the second rotor in the opposite direction. As a result, the body with the payload placed in it (or on it) begins not only to rise (lengthen) up into space, getting out of the Earth's gravitational pit, but also to rotate around the planet until it reaches the first cosmic velocity at a given height. The height that the GPV ring reaches and stabilizes at is determined by the excess of the initial kinetic energy of the rotor and the possibilities of elongation (stretching) of the ring.

The unloading of the GPV is carried out in special modules of the stationary orbital infrastructure located in the equatorial plane at an altitude of several hundred kilometers. In this orbit, it is proposed to place the entire heavy industry of Earth: plants, factories, workshops, power plants, chemical enterprises as well as the orbital settlements of earthlings serving this industry – scientists, engineers, technologists, machine builders, space builders.

The GPV landing on Earth is carried out in the same logic as the takeoff but in reverse order.

For one flight only (!) the GPV can deliver into orbit about 10 mln tons of all kinds of cargo³ and 10 mln passengers⁴. In a year, this giant self-supporting aircraft, using only its internal forces, will be able to go into space up to 100 times.

³ Modern astronautics will require at least 20,000 years for the same volume of transportation.

⁴ It would take more than 100,000 years to get the same number of people into orbit using modern launch vehicles.

The implementation of such an engineering solution as the GPV will reduce the cost of geocosmic transportation by more than 1,000 times – up to 1,000 USD (and even lower) per ton of cargo.

An environmentally friendly self-supporting GCT, operating exclusively on electric energy, will make it possible to carry out the industrialization of near space and ensure the removal of all industrial production harmful to the Earth's biosphere from the planet, creating them again in the near-Earth orbit. This will immediately open access to fundamentally new technologies with unique space capabilities that are not available on Earth. Tremendous prospects are also being opened in the field of information and energy communications. The removal of industry from the planet will radically improve the common habitat of people and living beings, the Earth's biosphere, especially in industrial regions, without any restrictions on the production growth.

Almost all engineering solutions used in the project are widely known, tested in practice and currently implemented in industry. The project has been repeatedly studied and verified by calculation methods. It is technically and economically justified. To implement it, there are enough opportunities and means even for one country, for example, such as the USA, China or Russia. In the 21st century humanity has everything it needs to carry out the project:

1) finances: you need about 3 tln USD (within 20 years – about 150 bln USD annually), i.e., 4–5 annual US military budgets;

2) metal (mainly steel): about 100 mln tons are required (for 20 years – about 150 mln tons of metal annually), i.e., as much steel as it is smelted in the world in a couple of weeks or as much as it is spent for a few months only to produce cars;

3) concrete: about 10 mln m³ is enough (for 20 years – about 500,000 m³ of concrete annually), i.e., approximately the same amount was spent on the construction of the Sayano-Shushenskaya Hydroelectric Power Plant;

4) electrical energy: the power consumption of the GPV (for the specified volume of geocosmic transportation) will be about 100 mln kW, which is commensurate with the power of a heavy Space Shuttle launch vehicle, or less than 5 % of the total power of the world's power plants⁵.

⁵ The GPV creates a stable load, unchanged during peak and low-load hours, which is the best option for generation. It increases the efficiency of the global energy system as a whole. In order to increase the efficiency of GPV sections connected to existing generating sources, it is possible to reduce slightly the consumption during peak hours and maximize it during low-load hours. This will increase the lifting time of the GPV but will improve the efficiency of the process.



The project implementation period is 20–25 years, considering sociopolitical, research, development, design and survey, construction and installation work.

Such a global geocosmic program will unite all developed countries of the world with common goals and objectives as well as attract them to the financing of this superambitious project designed to save humanity.

In the first years of the GPV operation about 100 mln tons of equipment, structures and materials will be delivered to the near space from Earth, sufficient to create the following elements within the equatorial orbits at an altitude of 300–500 km [77]:

1) solar power industry with a peak capacity of approximately 2 bln kW (this is the capacity of all power plants in the world today), since about 1 kW of power can be obtained from 1 m² of the surface illuminated in space. Fuel for these and subsequently built power plants – hydrogen in our Sun – will be enough for at least 5 bln years;

2) several hundred space settlements for long-term residence and work on the orbit for several hundred thousand people;

3) the basic linear platform of the Industrial Space Necklace "Orbit" (ISN "Orbit") with the relevant infrastructure communication (transport, energy and information) along it, made using string technologies, with a length of more than 42,000 km.

Around space string communications and infrastructure modules, as around catalysts, the "crystals" of the orbital industrial ring will grow up over time – laboratories, shops, factories, power plants and other industrial facilities. The personnel servicing the space industry will be able to live and work in the residential biosphere settlements built nearby with more comfortable conditions than on the planet. Eventually, the population will reach about 10 mln people (0.1% of the Earth's population).

Thus, during the 21st century the main part of the harmful terrestrial industry can be taken out of the planet by engineering means, precisely, can be newly created in the near space on circular equatorial orbits in the conditions of the space technological environment. To implement this plan, 5 tln USD of investments annually is quite enough – an insignificant part of what is planned to be invested in the program for "rescuing" the world economy, which is actually a program for genocide of civilization.

This will allow within about 50 years to complete reloading of our technogenic civilization to the cosmic vector of development according to a new resource logic under the motto: "Earth – for Life. Space – for Industry".

With a full-scale engineering approach based on reason and with the implementation of specific practical solutions presented in the previous chapters, the world of the 21st century, poisoned and suffocating in a crush of people and machines, can be changed in a short time.

An anthropogenic biota will be created on 1/15 of land (1/60 of the planet's surface). It will be able to feed and service all 10 bln people by that time. And the natural biota will be preserved on the rest of the land (14/15 of land, or 59/60 of the entire surface of the planet). This will ensure the natural biological regulation of the environment existed in the pre-industrial era. The main part of the technosphere will be in the outer space, while the remaining industries on Earth will include terrestrial agriculture and medicine, green transport and eco-infrastructure, ecologically friendly constructions and pedestrian linear cities as well as individual environmentally friendly structural elements of the general planetary power industry, communications and mechanical engineering.

Taking the industry into space will open access to inexhaustible mineral resources in the Solar System, in particular to heavy metals, the reserves of which are limited on Earth. For example, the asteroid Psyche, located in the asteroid ring of the Solar System between Mars and Jupiter, having a diameter of about 250 km and a mass of almost 10¹⁸ tons (million trillion tons), according to experts, consists of 90% iron and nickel [90]. And the gold reserves are estimated there as hundreds of billions of tons.

The Industrial Space Necklace of the planet will become a springboard for protection against cosmic threats (including meteorites) and a platform for the Earth's civilization expansion into deep space, where you can create various biosphere banks of samples of living fertile soils, microflora and microfauna, flora and fauna, delivered from Earth. Consequently, no human-made or natural cataclysms and catastrophes on the planet that can kill the Earth's biosphere won't be able to destroy thousands of enclosed and autonomous ecosystems located in orbit in space ecohouses.

The Earth's, no longer technogenic but engineering civilization, taught by the bitter experience of difficult relationships with the surrounding nature on its native planet, in its home – in the living biosphere, will take careful steps in space in order to fit into the surrounding space environment harmoniously – into someone else's (cosmic) house, although dead in the Earth's vicinity. This will enable our engineering civilization not only to survive but also steadily and indefinitely develop in the space and time of the infinite Universe.

5. Engineering Eschatology

5.1. Inevitability of Engineering

Everyone could feel the rain coming. Gust after gust. Approaching dusk and the rising tide. The Sun rises indomitably afterward.

Technocratic civilization has exhausted itself. It is in a crisis. It has only two ways – degradation or development. The possible vector of both is predetermined. It is a technogenic process that has degenerated into technocracy and is doomed either to perish or to transform into a new engineering mode. The critical situation reached in the first quarter of the 21st century is conditioned in two ways. On the one hand, as a deadlock, – the fundamental contradiction between techno- and biosphere. On the other hand, colossal engineering capabilities to resolve this contradiction.

Humankind has long contemplated on a reasonable readjustment. The hero of Victor Hugo's novel "Ninety-Three", thrown into the dungeon of an ancient tower, condemned to death at dawn, argues:

"You demand compulsory military service. Against whom? Against mankind. I object to military service; I would have peace. You desire to help the wretched; what I wish is the abolition of their misery. You demand proportionate taxation; I would have no taxes whatsoever. I would have the public expenses reduced to the lowest level, and paid for by the social surplus."

"What do you mean by that?"

"This: In the first place, it is for you to suppress sycophancy, – that of the priest, the soldier, and the judge. Then, use your wealth to the best advantage; distribute over your furrows all that fertilizing matter which is now thrown into your sewers. Three quarters of the soil lies fallow; plough it up; redeem the waste pastures; divide the communal lands; let each man have a farm, and each farm a man. You will increase a hundredfold the social product. At the present time, France affords her peasants meat but four times a year; well cultivated, she could feed three millions of men, all Europe. Utilize nature, that gigantic auxiliary; enlist every breeze, every waterfall, every magnetic current, in your service. This globe has a subterranean network of veins, through which flows a marvellous circulation of water, oil, and fire; pierce this vein of the globe, and let the water feed your fountains, the oil your lamps, and the fire your hearths. Consider the action of the waves, – the ebb and flow of the tides. What is the ocean? A prodigious force wasted. How stupid is the earth, to make no use of the ocean!" [91].

Previously, people were also thinking about the potential of the sphere of mind realized in technology, i.e., the noosphere. Konstantin Tsiolkovsky, the founder of rocket cosmonautics, created his cosmic philosophy. It is based on the principles of the unity of human and the Universe as well as the projective attitude of human to the world, assuming radical transformations of Earth, the cosmos and humans themselves with the help of mind. "Reason is the greatest force in the cosmos," the scientist kept repeating [92]. The cosmos is a unity of mind and matter, which is in the process of self-organization and evolution. Not only humankind is the bearer of reason. There are many intelligent beings inhabiting the Universe, and the Universe itself is endowed with reason. It arises in the process of self-organization, passing through a number of stages from the physical vacuum, through the emergence of quarks, gluon plasma, atoms, protoaggregation of galaxies, then the emergence of galaxies themselves, stars, planets, biosphere, anthroposphere, socio-sphere and, in fact, the sphere of reason, called noosphere in the works of Vernadsky.

According to Tsiolkovsky's assertion, the latter is the peak of self-organization and the determining factor of further development of the Universe. The main actors in this process on the scale of Earth are geniuses: "Geniuses have performed and are performing miracles. Who does not know it!" [93]. Geniuses "are needed not only for the circulation and assimilation of truths already discovered long ago, although not used by people, but also for the generation of new ones. Moral and every kind of light emanates from geniuses" [93]. "The thoughts of geniuses are immortal as well as their deeds, because even after death they continue and give infinite and limitless fruit" [93].

Vladimir Vernadsky agrees with Konstantin Tsiolkovsky that human and humanity cannot be understood if we consider them in isolation from more global processes and phenomena. First of all, according to Vernadsky, human is connected with the "living natural body" and "living matter" of the environment – the biosphere. At that, the scientist understood "living matter" as the whole "totality of the living organisms inhabiting it" [94]. Living matter is in constant intensive interaction with the nonliving part of the biosphere and outer space. "The matter exchange is implemented through the atomic movement caused by the living matter... The planetary, cosmic significance of the living matter manifests itself just in this biogenic flow of atoms and in the energy involved in it. For the biosphere is the only envelope of the Earth into which the cosmic energy and cosmic radiation permanently penetrate. Cosmic radiation, first of all the solar one, supports the dynamic

equilibrium and the organization between the biosphere and the living matter" [94].

The activity of reason transforming the biosphere turns out to be a part of not only local, terrestrial processes but also the life of the Universe as a whole. "By his scientific thought and state-organized technology generated by this thought, by his very life, man creates a new biogenic force in the biosphere: the force directing his reproduction and creating favorable conditions for the settlement of man in such parts of the biosphere whereto his life (in some places, even any life at all) previously did not penetrate. Theoretically, we do not see any limit for his potentialities..." writes Vernadsky [94]. Humankind on the scale of the planet fulfills a controlling role, and its entry into space is a natural and inevitable stage in the evolution of the biosphere and the Universe as a whole. However, it can happen under certain conditions, associated by the scientist with the formation of the noosphere.

Consequently, two moments are the prerequisites for the replacement of the anthroposphere by the noosphere: the domination of human over external nature and the domination of the forces of mind over the lowest instincts in humans themselves. "...The course of the history of the scientific thought becomes for us a natural process of the history of biosphere. The historical process as the manifestation of the world history of the mankind is revealed before us in its one but cardinal consequence, as the natural phenomenon having essential geological significance" [94].

In order for the noosphere to emerge, it is necessary to unite humankind. Vernadsky believed that already in his time, by the middle of the 20th century, there were all prerequisites for that: "The first time in the history of the mankind that we live under the conditions of the united historical process that embraced all the biosphere of the planet" [94]. At the same time, Vernadsky was one of the first who felt the importance of transition to a new quality and realized that otherwise humankind would perish: "It is for the first time that a man had recognized himself as an inhabitant of the planet and may (and must) think and act from another viewpoint – not solely from that of a separate personality, family, or kin, state, union of states, but also from the planetary point of view" [95].

In the 21st century, when global environmental, political and other problems are reaching the peak of their significance, these ideas are acquiring a second birth, however, Vernadsky does not say much about how exactly the transition to the noosphere is possible. According to the generalizations of Fidana Yanshina, a researcher of his work,

the Russian scientist formulated the following 12 conditions for the formation of the noosphere in the future [96]:

- human settlement of the entire planet;
- a dramatic transformation of the means of communication and exchange between different countries;
- strengthening of ties, including political ones, among the nations of Earth;
- predominance of the geological role of human over other geological processes occurring in the biosphere;
- expansion of the biosphere's boundaries and entry into space;
- discovery of new energy sources;
- equality of people of all races and religions;
- increase in the role of people's masses in solving issues of foreign and domestic policy;
- freedom of scientific thought and scientific search from the pressure of religious, philosophical and political constructions as well as the creation of conditions favorable to free scientific thought in the social and state system;
- improvement of the workers' well-being. Formation of a real possibility to prevent malnutrition, hunger, poverty;
- alleviation of the impact of diseases;
- intelligent transformation of the Earth's primary nature to make it capable of meeting all the material, aesthetic and spiritual needs of the numerically increasing population;
- elimination of wars from the life of humankind.

As Vernadsky believed, many of the conditions necessary for the transition to the noosphere had been fulfilled. The unity of civilization, living matter, biosphere and space has been achieved through engineering and technology. So far, this unity is negative. It has a destructive nature. It is the unity of war. A unity of entities clashing to the death in the darkness of the Universe. But the light of mind lurks in that darkness. Either it triumphs and a star blazes or darkness will engulf everything.

The positions of mind are still strong. In 1793, when the revolutionary calendar was introduced in France and a new era was ushered in, the meaning and possibilities of engineering were just being discovered. Humanity did not have a hundredth of the technological power, which it has in the 21st century. Nevertheless, people dreamed. People are still dreaming today. They have everything in their hands to realize their dreams. How to do it? We have been discussing this throughout our research. Now it is time to summarize the results.

1. Engineers have created our civilized world.
2. Engineering inventions, which have become technology in the global sense, have engaged in a battle with nature. As a result, civilization turns out to be a mighty locust, devouring everything in its path like mold, taking over and destroying every last square millimeter of its own home.
3. The evil brought by engineering comes from the fact that the engineering itself remains beyond good and evil. Engineering cannot be morally neutral without posing a mortal threat to its creator.
4. Engineering should absorb the space of morality in the same way that medicine and jurisprudence received ethical regularity in the Middle Ages.
5. Engineering, as a toolkit for solving problems while meeting the requirements of maximum efficiency in conditions of limited means and while accepting life as the supreme goal should become the goal-setting structure of civilization to ensure its survival.

6. Engineering can and should become a supreme value, provided that at the same time life is recognized as a supreme goal.
7. Technocratic civilization, completely exhausted, will be reduced to a primitive state or transformed into an engineering civilization.
8. Transformation mechanisms can be launched through the implementation of large-scale projects aimed at a global civilizational transformation. The logic of small engineering steps is a priori untenable because it cannot compete with market megaprojects launched by states and corporations in order to obtain immediate benefits for a narrow circle of power "elites".
9. The world capitalist elites are not interested in the implementation of global projects significant for noospheric development. For them, it will mean the loss of control over the situation and destabilization of the system in which they have surrounded themselves with a zone of maximum comfort.

10. Realization of large engineering projects aimed at global technological transformations and preservation of decent conditions of life development for people can be carried out by the efforts of people themselves. Technological solutions of the 21st century allow to launch megaprojects privately. This does not necessarily require the participation of the state, but every state is interested to get involved in such projects in order to preserve itself in a modified, improved shape.

11. Engineering cannot and should not manage society. It is a mediator between nature and human, and therefore, as a supreme value, it is called to become the harmonizing apex of the noosphere triangle. Engineering is called upon to serve humanity. It should be the god that responds to our requests. Engineers will become its priests.

12. Acknowledged, accepted as a supreme value and goal-setting structure, engineering embodied in technology is the primary intelligent means of preserving and enhancing humanity. By conquering the boundaries of the physical world, engineering reveals the boundlessness of the world and the possibilities that the infinite Universe holds.

Once the boundary of the world for human was drawn by a line on the horizon. Engineering genius created the ship. Columbus sailed to discover America with little more than a compass for navigation. His ships didn't even have a helm, they steered with a lever. They suffered and died from scurvy, not knowing that it could be avoided by simply taking some sauerkraut and lemons on board. Magellan had sailed for months in the Pacific Ocean, seeing around him nothing but sea and sky. He expected that he was about to reach the shore. This was evidenced by all the maps, which turned out to be made on the basis of calculations, where the length of the equator was shorter by several thousand kilometers. Nevertheless, they were achieving their goals and, armed with engineering, were moving civilization forward. The people of the 21st century have much more at their disposal than the pioneers. Their discoveries can and should be much more far-reaching.

5.2. The World as an Engineering Project

For thousands of years, humans have been living on the surface of Earth, constantly making and improving their discoveries, only guessing what is happening above and below them. Not only the center of our planet, which has a temperature of about 6,000 °C and a pressure of 3.7 mln atmospheres, has not been examined, but even the World Ocean is explored by less than 5 % to date. This is because 98 %

of the ocean floor lies at a depth of more than 6 km. We study the structure of Earth theoretically with the help of the physics of oscillatory-wave processes by the propagation of disturbances during earthquakes.

Oceanologists conduct deep-sea research using various instruments (hygrostat, bathyscaphe, bathysphere, etc.), but only at relatively shallow depths. Again, deeper layers can only be guessed at or judged by indirect indications. Nobody has ever been able to see with their own eyes what is happening right next to us by cosmic standards. Researchers are only contemplating plans to drill through the Earth's crust and penetrate to the mantle through it to gather information about Earth or to dive beneath the thickness of the vast oceans.

Perhaps, it is a good thing that humankind is being in its unenlightened spiritual and moral state so far, oriented towards exploitation of the planet and profit, has no opportunity to penetrate these deep spheres as much as we have little opportunity to penetrate space. Offshore oil extraction threatens the ocean ecosystem. In the 20th century, the world's waters have been shaken by dozens of major disasters such as oil rig explosions, tanker wrecks, ship collisions and oil spills (tens of millions of barrels) during regional conflicts. In 1991, during the Gulf War, an oil spill killed more than 30,000 birds. Oil wells had been burning for months, and black rains had been falling over an entire region, including Turkey, the UAE and Kuwait; hundreds of oil lakes took decades to dry up.

In 2010, the oil spill disaster in the Gulf of Mexico had killed tens of thousands of birds, marine mammals and fish, caused massive plant mortality and soil erosion. The consequences of these monstrous abuses of the planet require many years of thorough work to clean up the waters and restore conditions close to those that had existed before. And this is despite the fact that the consequences of accidents are impossible to eradicate completely in the next dozens of years, even on the condition that no more of such disasters will occur during the entire recovery period.

As for the causes of catastrophes, they are all the same: failure to study Earth before drilling; rushing to develop an oil field as soon as possible; improper operation of equipment and failure to apply the necessary safety measures; trying to harm the enemy during a conflict; etc. All of the above is the result of the fact that engineering remains just a tool in the hands of capital and is forced to dance to its army drums leading to slaughter.

Humankind is not frightened by its own mistakes, although it sees and feels the terrible consequences of its deeds.

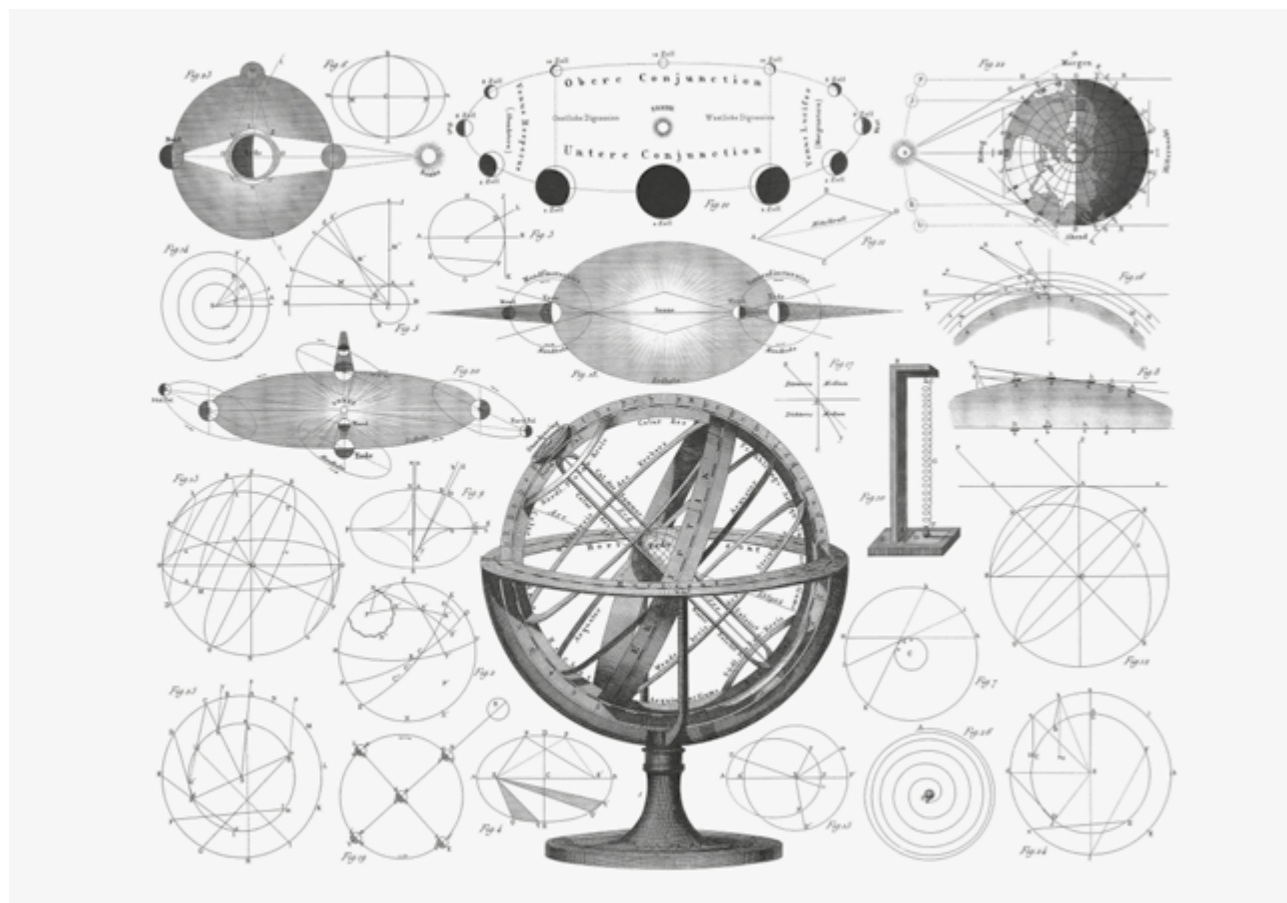

The official cause of the disaster in the Gulf of Mexico was a management error in the development of the oil field. No matter how many accidents there have been, the paradigm of management in its desire to make money at any cost is not changing. And behind those few guilty people who will be probably punished for the ruthless destruction of life on Earth, there are already thousands of the same cynical "managers" who are ready to test the world for strength, satisfying their greediness.

We know, although we have not seen the core of Earth itself, that it creates a magnetic field, without which the solar wind will reach the surface of the planet and destroy all living things. We know that biogenic substances of the deep layers of the ocean, i.e., phosphates, nitrates, are fertilizers, which, when carried by the current to the upper layers, create the necessary conditions for life. And the productivity of phytoplankton itself is comparable to that of land plants. We are aware that the ozone shield protects us from solar radiation and that life under direct ultraviolet radiation would be impossible for us. Both gravity and the atmosphere, in which celestial bodies burn up, protect us by counteracting powerful external forces that could destroy all life on our home planet.

The conditions for the emergence and existence of life seem to be thoroughly designed by someone in the Universe and on Earth. For example, the gas balance of the atmosphere, among other parameters, has a constant ratio of oxygen (21 %) and a small amount (less than 1 %) of the main greenhouse gases – water vapors and carbon dioxide. If the balance is shifted towards an increase in these gases, the greenhouse effect will increase, climate change will follow, ocean level will rise, and global warming will accelerate. If the balance shifts towards an increase in oxygen content, oxidative processes on the planet will become much more intense, forest fires will become even more frequent, which will significantly change the circulation of all organic and inorganic substances.

The world is arranged in an amazingly expedient way, and the interrelationships between substances and processes are innumerable. In fact, the deeper scientific knowledge advances, the easier it becomes to believe in God – so magnificent is the Universe. Forces and energies are balanced and aligned with each other with exact precision. Some might argue that the current state of the world is the result of the long-term formation of the planet, which has been subjected to serious tests and cataclysms for billions of years. It is so, but this makes the originated life even more marvelous and valuable because such conditions for its appearance on the planet could not have arisen at all. Moreover, the space

explored by people is not suitable without special technological equipment for the existence of human, albeit technogenic, civilization. And certainly, the celestial bodies known to us are not suitable for the emergence of life as such.

A human as a living being commensurate to the reader and as a single organism consisting of trillions of cells, thousands of organs and biomechanisms (only when we smile, up to 53 facial muscles work) is arranged much more complex than the entire observable Universe, all its inanimate part with billions of trillions of stars. Even a tiny component of living cells – each DNA molecule containing the most complex spatially structured billions of atoms of dozens of chemical elements – is, from the engineering point of view, an incredibly more complex structure than, for example, the entire aggregate inanimate Earth's industry created by billions of people over millennia.

If DNA is compared, for example, to an airplane, it is about a million times more complex than it. However, without bioengineering communications (nervous, cardiovascular, respiratory, digestive, excretory, reproductive, endocrine, immune and integumentary systems with millions of complex "sensors" – receptors) with information channels from sense organs (vision, hearing, sense of smell, touch, etc.) would DNA macromolecules be assembled into a cell, cells – into organs, and organs – into a human organism? Even if they had assembled, would such an organism be able to exist as a random set of "parts" and "bricks", as something whole and stable without the abovementioned transport and communication bioengineering systems, including 100,000 km of vessels and 200,000 km of nerve fibers in the human body?

Those who believe that life could have originated by chance and perhaps exists or has existed in some forms elsewhere must still be aware of how rare and negligible such a probability must be. This probability is unimaginably low. For the accident advent of life, it would take a trillion times longer period than the age of our Universe.

So, who (or what?), why (randomly or by intelligent design?), how (haphazardly or as planned?) and why (for the sake of dead matter or for the sake of intelligent life?) created our world and tuned it so finely? If the fundamental constants and initial conditions included in the laws of physics (mass of proton, neutron and electron, Planck's constant and gravitational force, weak interaction and cosmological constant, change of energy density and three-dimensionality of space, etc.) differed from the existing values by at least one thousandth, there would be neither atoms, nor molecules, nor stars, nor planets, nor highly organized matter, nor intelligent life in our Universe.

Scientific skepticism claims that if eternity is multiplied by dozens of billions of trillions of stars in the Universe, we will get life somewhere. But what is randomness, can be considered both necessity and regularity. Indeed, both the internal expediency of Live Nature, which Aristotle called "reason acting on its own" [97], and the presence of consciousness in human, with its distinction between moral forms and what Kant defined as the "categorical imperative" [98], lead us to the idea of a rational prime cause. Anyway, the world is organized expediently and reasonably – as far as it is possible for human to comprehend expediency to the extent of reasonableness. Earth's human civilization, getting at its disposal more efficient ways of resource extraction and energy management, is engaged in undermining natural world systems. The safety margin of planet Earth is truly great, but it is not infinite.

For thousands of years people have poorly studied the world in which they live, they still have little understanding of the laws operating in it, but they persistently destroy everything around them and do not pay attention to the consequences. And if the world had been designed by one of those "successful managers" who care about the safety margin of a product only as much as the product can be sold more efficiently and for the greatest number of times, people would not had existed long ago.

In part, this feeling of isolation from higher-order meanings and the idea of an earthly life, in which it is necessary to grab as much as possible, form the consciousness of a successful ambitious person of the 21st century. Fortunately, the safety margin of the created world gives us time to come to our senses and deal with this profoundly wrong approach. The process has already started, and this problem will not be solved by itself because those who are rocking the boat will persist in their crazy business with the persistence of morons until we all, together with the boat, sink.

5.3. God as an Engineer

We do not know the temporal beginnings and spatial boundaries of the world. Nor do we know what awaits us at the end of time, nor do we know if human history will ever be completed. The fate of life as such on our planet depends on us only partially and may one day continue without our participation. Thus, we influence only the possibility of our own survival at this point in the development of the world. Then what is our freedom of choice if not to be reasonable beings in a reasonable nature? And for nature, reasonableness consists in preserving life by any means and under any conditions. Nature knows no agonizing contradictions or bifurcation. It is endowed with a relentless will to overcome and acts,

including in every living organism, according to its own laws by itself, like an element. We can say that life is always busy reproducing itself – such is its nature and its meaning.

Only people realize the world of separate and alienated objects, feel their mortality in it and in one way or another reflect on what happens to them. From this, there arise, even if not always conscious, attempts to define one's own meaning and relate to the world and other people. To replenish the content of life through activity and the creative act or to dissolve into principled thoughtlessness and pleasure, to rise in the material world or to diminish in the spiritual world, to mature in godlessness or to grieve in God's abandonment. Thinking in this sense is the opposite of vitality as a natural force because if we subtract thinking (reason) from a human being, we are left with only a living being, i.e., an animal. That is why, in this conflict, the mass culture of the 21st century works to reduce consciousness to vitality and to reduce thinking to stupidity. Then "animal rationality" will allow us to take and do what we want by the right of the strong, to seek only our own satisfaction and to destroy each other openly. Many people live this way... Many will live this way no matter what. But if the majority become like the many, all will perish.

Our survival should take place only on the condition that we do not lose our human image, and we may not worry about life in a state of savagery – it will make its own way, as it has occurred before, during billions of years of evolution on our planet. It is important to be preserved precisely with those high achievements in the fields of knowledge that we have acquired over all these centuries, it is important to preserve the ability to think and act reasonably.

Human rationality is thought of as a state in which thinking overcomes dissociation from the world and something individual as the overriding principle. This reasonableness includes the whole historical experience, spirituality and creativity. What is reasonable cannot be immoral, and in this sense no category in itself, in isolation from the universal, can claim to be absolute. Rationality as such is irrational if it is immoral and does not serve the purpose of preserving life and affirming its status as the highest value. The rationality of concentration camps that exterminate doomed prisoners efficiently and systematically, using their blood for transfusions to their wounded soldiers, hair – for overcoats, ashes – for fertilizer, is senseless. Rational but senseless are Malthus's ideas of population regulation; also, one-sided and unreasonable are the explanations of the historical development of society solely on the basis of production relations in Marx's economic theory. Senseless and irrational, but trying

to appear so, are Schwab's ideas of inclusive capitalism, universal digital control and the abolition of nation states.

The truly global challenge is to completely change the paradigm and establish new value orientations. Civilization can integrate into the reasonable Live Nature and not destroy it as a resource, but let it develop for the benefit of humankind. In time, it will help people to obliterate the consequences of their own unreasonable actions. We can get involved in this process only with the help of engineering. This will be the reasonableness of human beings, which is synergistically interconnected with the natural reasonableness through technical achievements. In such a case, humans will be enabled due to their consciousness to rise above the unenlightened element of the wilderness where life engulfs life. If engineering as a tool and method is placed at the service of reason, and reason is guided solely by moral goal-setting and moral orientations, then engineering also becomes a reasonable and, consequently, moral force at human's disposal.

Thinking as such makes us humans, but in order to be intelligent, human needs spiritual and moral goals that will not allow our thinking to work to self-destruction or to use each other.

Thinking, if only it is able to be preserved in the Universe as a phenomenon, should not be in contradiction with natural vitality. Thinking must be directed towards the creation and defense of life, engineering creativity and solving the problems of humanity that will be posed to it. Such benevolent thinking denies the dark irrational side of the human soul and the phantasms it produces. For rational thinking there is an objective truth, universal salvation and the transformation of the world. There is the prospect of development and the hope for a better future in harmony with nature. In a world guided by such principles, personal benefit will never supersede the common good or the life of another, and achievements will be morally justified and put at the service of human.

In the 21st century, people put their hope on thinking that will overcome the conflict with vitality, having in mind spiritual guidelines. People can only trust in rationality, which will be guided by moral rules, and ultimately in engineering, which should save from extinction or a return to primitive barbarism. Because the world was created by engineers. Only engineers can maintain and preserve this world.



P. S.

So why should we save the world and what is the sense of humanity's life? It is our task to save the world not only because it is expedient, beautiful and built according to the anthropic principle, but also because the knowledge of ourselves, the essence of existence and the definition of the meaning of life is the conceivable limit that is set before human as a being not so much material as spiritual.

It is necessary to save the world so that we and our descendants at least have an opportunity to ask ourselves these questions and answer them on the basis of our perceptions and knowledge about the World.

The individual sense of each person's life will never be learned if we all do not have a chance to survive and be saved from madness. Salvation in turn cannot be exclusively individual. On the contrary, it presupposes universal salvation and restoration of the world.

If we talk about the sense of life of all humankind, it is inconceivable without spiritual growth.

The result of rational human activity should be the transformation of the biosphere into the noosphere, which, according to Vernadsky, occurs under the action of a special energy: "This new form of biogeochemical energy, which can be called the energy of human culture or cultural biogeochemical energy, is the form of biogeochemical energy that creates the noosphere at present" [94]. The culture we create is meant to transform the world. This is the sense of humanity. We fit out the world like gardeners shape their gardens. Cultivation of the garden, active work in it or contemplation of its beauty is a form of cognition of existence and ourselves, leading us to new horizons of senses. And if we are truly intelligent, we are chosen to be responsible for all life on our planet.



PRAYERS OF THE WORLD ENGINEER

An engineer is a part of society, he is also a part of the Universe, incomparably larger than himself, than the whole of Humanity and Life itself. Life is but a tiny living part of the material Universe, perhaps a trillionth or even less, even if all the planets of the Universe were inhabited by living beings. Therefore, the acceptance of engineering as the highest value of civilization must involve some kind of self-definition of the engineer and engineering itself on the scale of the Absolute. Somehow the engineer, as creator, should relate to the Creator of all things, whatever we mean by that – the objective laws of the Universe or the subjective will of the Deity who have created and controls all things. Traditionally, one form of correlation between human and the Absolute is prayer.

The word "prayer" in the English version comes from a Proto-Indo-European root meaning "to pray". In the Russian version, despite the difference in sound, the essence is the same. The concept goes back to Old Slavonic *molíti*, from Proto-Slavonic *moliti* and means "to ask for something" (from God, Gods, Goddesses). There is also a consonance with *malyy* ("small" in English), *umalyat'* ("to diminish" in English), i.e., to evaluate something as less in relation to something more significant and important. Thus, in prayer, at different times, in various languages, countries and on different continents, people in many ways recognize their smallness in relation to the powers that rule the World and ask these powers to condescend to them, to grant their requests.

As defined by the Concise Dictionary of Religion and Philosophy, prayer is "an important part of the spiritual life of a believer, his relationship with God, either individually or in a community of other believers, often an outpouring of the soul, presented to God with an open heart, in reverence, trust, hope and love... Prayer is not a retreat from the world, not a floating in higher spheres but a desire to enter better into the affairs and problems of life under the sign of His will and His plan. Prayer is a means of reconciliation with God, a source of knowledge of God, knowledge of God's ways in the world and the attainment of inner peace" [99]. From this we can conclude that prayer is also an inner motivation for creativity, since human never saw himself as an exclusively passive participant of the events, but even in the logic of heroic fatalism, the ancient Greeks saw themselves as free men, despite the pressure of fate and the predetermination of destiny. At least in the way of accepting fate – with despondency or gratitude, with cowardice or with dignity and courage. All this is very important in engineering, as long as it really changes the world around us. It is important that human's design does not contradict the design of God or Nature, whether the engineer is an atheist or a believer. No one creates in a spiritual vacuum. Moreover, creativity is always a quest for unity with the Absolute, no matter how it is interpreted.

However, if an engineer is an atheist, does he need prayer? My answer is yes. It is not only necessary but essential in two ways. Firstly, from the point of view of meditative concentration on one's vocation and place in the World. Secondly, from the point of view of understanding and recognizing oneself as a small particle of the Universe, participating through actions in events of universal scope and, although only a grain of sand, having its own price and weight, as defined by Blaise Pascal: "Man is but a reed, weakest in nature, but a reed which thinks. It needs not that the whole Universe should arm to crush him. A vapor, a drop of water is enough to kill him. But were the Universe to crush him, man would still be more noble than that which has slain him, because he knows that he dies, and that the Universe has the better of him. The Universe knows nothing of this" [100].

What should an engineer believe in if he is not obliged to believe in God? To whom, then, should he pray in order to maintain his commitment to purpose and his awareness of his own place as a "reed which thinks"? And should Faith, as acceptance without proof, be an element of the engineer's prayer? No, it shouldn't. It may be enough for an engineer simply to admire the Power that was not afraid to build the World in which we live and create – Time, Space, Matter and then life and Human. It is enough for an engineer to marvel at the Creator of Time, Space, Matter and their derivative – Human. An earthly engineer who creates a nut, a wheel, a car or an airplane can limit himself to worshipping the Creator of the Prime Causes in whose horizon his own life and creativity take place. And such worship is essential. It is also necessary to allow oneself to act, to be and to resemble in action that much greater Engineer who created everything – our whole World.

The engineer can address his prayer to the God he believes in. If the engineer does not believe in God, he can address his prayer to himself. In this way he gets rid of the fear of creating something great – something that will not always be perceived by other people but will serve them.

The engineer should allow himself to become superior than "just a human", just as every artist and every true professional does. However, there is no vanity or pride in this, as long as the engineer's role is properly understood. The doctor commands the patient, but in so doing he serves him. An artist, when painting a portrait, makes kings assume the pose he wants, but in so doing he serves the kings. It is the same with the engineer. He must allow himself to step back as "just a human" in order to serve Humanity.

The definition of prayer says about the connection with God. But it doesn't say with which one. No particular God is specified. My God is the one who molded this triune World – Time, Space and Matter – with filigree engineering precision and perfect thoughtfulness. He invented the laws (including gravity) that govern this World, but not God Himself, who created our world. Even gods cannot control this unimaginably complex World, in which there are only about 100^{100} elementary particles, which every second can give rise to the most diverse variants of combinations with each other in even more 100^{100} quantities, including the materialization in a definite Human consisting of about 30 tln cells and 100 tln useful microorganisms inhabiting it. But each of these simple living beings is millions of times more complex than any factory, airplane or spaceship. Look around at this unimaginable complexity of Being and look at the sky, where there are trillions of galaxies alone. From these positions I am a believer, although I understand (this is my personal perception) that such a complex engineering Enterprise, as the World (engineering is not only materiality but also spirituality, morality and sociality arising from its material carriers), cannot have a single boss – director or manager. I am convinced that my belief will not offend anyone, just as I do not think that a believer in Allah offends those who believe in Christ or Buddha.

I have my own prayers, the main purpose of which is to constantly remind myself of my own smallness, even insignificance, in the vast Universe and at the same time to maintain the determination to be and create according to my destiny, perhaps given from above. God grants the most complex, difficult and impossible to achieve on earth only to those who are strong in spirit. Here are my prayers.

I

Let it be as I think, in keeping with Your will, O Lord.

II

With my thoughts, words, intentions, actions and deeds I create the Reality in which it is easy, comfortable and safe for me, my family and friends and everyone on planet Earth to live, work and study today, tomorrow, the day after tomorrow and the day after that.

III

I thank You, Lord, for everything.

I thank You, Lord, for having created Time, Space, Matter – Energy, Quantum Fields, Elementary Particles, Atoms, Molecules as well as the Laws of existence and development of this harmonious World, in particular Gravitation, – all that we, people, today call the laws of physics.

I thank You, Lord, that Gravity gathered Matter into Stars and ignited them, gathered Stars into Galaxies and Galaxies into the Universe as the ultimate manifestation of the Creator's engineering.

I thank You, Lord, that Gravity gathered cosmic gases, stardust and rocks into the Solar System and ignited the Sun, created the planets and Earth, without which Life and living beings in all their biodiversity would not be possible.

I thank You, Lord, for creating Human, giving him Intelligence and guiding his development along the technological path.

I thank You, Lord, that the technological path of development has created human societies, nations, states, Humankind and Earth's Civilization.

I thank You, Lord, that thousands of generations of earthly engineers, in the image and likeness of Your Creation and within the framework of Your Laws, have created the modern engineering Civilization, passing from stone tools, the first fire and the wheel to the automobile, the computer and the spaceship.

I thank You, Lord, that our Earth's engineering Civilization gave birth to me, Anatoli Unitsky, and gave me the mission to become the World Engineer, honoring the Laws created by You.

I thank You, Lord, for what I am. For being able to think, feel, love, create, make, invent. For being able to breathe, see, hear, touch, smell, taste. For being healthy and happy. For becoming the World Engineer.

I thank You, Lord, that I have my Home – the Biosphere of the Space Home named Planet Earth, in which I, together with my closest relatives – billions of species of living organisms – live harmoniously.

I thank You, Lord, that I have a beloved Family, Wife and Children, beloved Relatives, Friends and Close ones, beloved Colleagues, Supporters, Like-minded people and Investors, beloved Kin, Nation and Earth's engineering Civilization.

I thank You, Lord, for being able to create Unitsky's engineering schools: scientific, project, designing and manufacturing.

I thank You, Lord, for the fact I have a Tool for implementation of biospheric technologies that can save the Earth's engineering Civilization – Unitsky Group of Companies.

I thank You, Lord, for granting me the Mission – to save the Earth's engineering Civilization from degradation, extinction and death on planet Earth limited in size and resources through the substantiation and implementation of the Cosmic vector of civilization development in the Universe unlimited in Time, Space and Resources.

IV

I give myself permission to love and be loved.

I give myself permission to be perfectly healthy.

I give myself permission to be perfectly happy.

I give myself permission to experience an absolute joy.

I give myself permission to be a long-lived person.

I give myself permission to be a sage.

I give myself permission to be victorious in all my fights, battles and wars.

I give myself permission to be the savior of the Earth's Biosphere from the oppression of the Technosphere.

I give myself permission to be an outstanding founder.

I give myself permission to be the greatest creator.

I give myself permission to be a brilliant maker.

I give myself permission to be the most efficient engineer.

I give myself permission to be the most productive engineer.

I give myself permission to be the most abundant engineer.

I give myself permission to be the most successful engineer.

I give myself permission to be the most brilliant engineer.

I give myself permission to be a genius.

We, humans, are incapable of understanding and realizing the Universe created by God, neither now nor in the future, just as insignificant small parts are incapable of understanding the whole – the comprehensive World composed of them. Separate living cells are incapable of understanding and realizing the living organism of which they are a part, whereas the organism, if it has a mind, is capable of understanding the cells of which it is composed. I give myself permission to be the local messiah who came to save the Earth's engineering Civilization from degradation, extinction and death on planet Earth limited in size and resources, better than which, more beautiful and dearer to us, earthlings, there is and will be nowhere and never in the vast Universe.

The World Engineer
Anatoli Unitsky,
Minsk, Maryina Gorka,
April – June 2023

References

1. Unitsky, A. *Historical Background of the SpaceWay Program as the Only Way of Sustainable Development of the Technocratic Civilization* / A. Unitsky // *Non-Rocket Space Industrialization: Problems, Ideas, Projects: Collection of Articles of the II International Scientific and Technical Conference, Maryina Gorka, Jun. 21, 2019* / Astroengineering Technologies LLC; ed. A. Unitsky. – Minsk: Paradox, 2019. – P. 23–29.
2. *Biologicheskiy enciklopedicheskiy slovar: Chelovek [Biological Encyclopedic Dictionary: Human]* [Electronic resource]. – Mode of access: <https://gufo.me/dict/biology/%D1%87%D0%B5%D0%BB%D0%BE%D0%B2%D0%B5%D0%BA>. – Date of access: 12.05.2020.
3. *Protolyudi izobreli kop'ya na 200 tysyach let ran'she, chem schitalos' raneye [Protohumans Invented Spears 200 Thousand Years Earlier Than It Was Previously Thought]* [Electronic resource]. – Mode of access: <https://ria.ru/20121115/910928482.html>. – Date of access: 05.06.2023.
4. *Iz-za chego odna voyna v Yevrope shla 300 let, ili Pochemu nekotoryye konflikty prodolzhalis' vekami [Why One War in Europe Was Fought for 300 Years, or Why Some Conflicts Lasted for Centuries]* [Electronic resource]. – Mode of access: <https://kulturologia.ru/blogs/201221/52012/>. – Date of access: 05.06.2023.
5. Dudakov, D.S. *Istoricheskaya retrospektiva roli transportnykh setey v razvitiy gorodov [Historical Retrospective on the Role of Transportation Networks in Urban Development]* / D.S. Dudakov // *Architecture and Modern Information Technologies*. – 2018. – No. 3 (44). – P. 225–243.
6. Khusainov, F.I. *Evolutsiya zheleznodorozhnoy otrasli v SSHA: uroki dlya Rossii [Evolution of the Railway Industry in the USA: Lessons for Russia]* [Electronic resource] / F.I. Khusainov // *Kapitalizm i svoboda: Materials of the IV International Conference, Saint Petersburg, Apr. 11, 2015*. – Mode of access: https://www.hse.ru/data/2015/08/17/1088189079/rail_usa11042015.pdf. – Date of access: 03.06.2020.
7. *List of Countries by Road Network Size* [Electronic resource]. – Mode of access: https://en.wikipedia.org/wiki/List_of_countries_by_road_network_size. – Date of access: 20.06.2020.
8. De Vries, A. *Bitcoin's Growing Energy Problem* / A. de Vries // *Joule*. – 2018. – Vol. 2, No. 5. – P. 801–805.
9. *Falcon 9 startovala na orbitu s novoy partiyey iz 60 internet-sputnikov Starlink [Falcon 9 Launched into Orbit with a New Batch of 60 Starlink Internet Satellites]* [Electronic resource]. – Mode of access: <https://www.interfax.ru/world/683798>. – Date of access: 07.07.2020.
10. Bolt, J. *GDP per Capita Since 1820* [Electronic resource] / J. Bolt, M. Timmer, J.L. van Zanden. – Mode of access: <https://dspace.library.uu.nl/bitstream/handle/1874/306235/3014041ec007.pdf?sequence=1&isAllowed=y>. – Date of access: 07.07.2020.
11. Cilluffo, A. *World's Population Is Projected to Nearly Stop Growing by the End of the Century* [Electronic resource] / A. Cilluffo, N.G. Ruiz. – Mode of access: <https://www.pewresearch.org/fact-tank/2019/06/17/worlds-population-is-projected-to-nearly-stop-growing-by-the-end-of-the-century/>. – Date of access: 07.07.2020.
12. *Otkuda poyavilsya vodorod vo Vselennoy [Where Hydrogen Came from in the Universe]* [Electronic resource]. – Mode of access: <https://clck.ru/34wTXQ>. – Date of access: 06.06.2023.
13. *Solntse polnost'yu pogasnet cherez 5 milliardov let [The Sun Will Get Completely Extinguished in 5 Billion Years]* [Electronic resource]. – Mode of access: <https://mirkosmosa.ru/p/pub-3090-solnce-polnostyu-pogasnet-cherez-5-milliardov-let>. – Date of access: 06.06.2023.
14. Malthus, T.R. *An Essay on the Principle of Population* [Electronic resource] / T.R. Malthus. – Mode of access: <https://archive.org/details/essayonprincipl00malt/page/n21/mode/2up>. – Date of access: 07.06.2023.
15. *Golod v Irlandii (1845–1849) [Famine in Ireland (1845–1849)]* [Electronic resource]. – Mode of access: <https://clck.ru/34wTZF>. – Date of access: 07.06.2023.
16. Hitler, A. *Mein Kampf* [Electronic resource] / A. Hitler. – Mode of access: https://mk.christogenea.org/_files/Adolf%20Hitler%20-%20Mein%20Kampf%20english%20translation%20unexpurgated%201939.pdf. – Date of access: 07.06.2023.
17. *Zelonaya revolyutsiya [Green Revolution]* [Electronic resource]. – Mode of access: https://alphapedia.ru/w/Green_Revolution. – Date of access: 07.06.2023.
18. *The Limits to Growth* / D.H. Meadows [et al.]. – New York: Universe Books, 1972. – 205 p.
19. *Genotsid na plodородной почве [Genocide on Fertile Soil]* [Electronic resource]. – Mode of access: <https://www.kommersant.ru/doc/2624240>. – Date of access: 08.06.2023.
20. *Diamond, J. Collapse: How Societies Choose to Fail or Succeed* [Electronic resource] / J. Diamond. – Mode

- of access: <https://archive.org/details/collapse-jared-diamond/page/n1/mode/2up>. – Date of access: 08.06.2023.
21. Global Population Control [Electronic resource]. – Mode of access: <http://boris-johnson.com/2007/10/25/global-population-control/#more-381>. – Date of access: 08.06.2023.
 22. Department of Economic and Social Affairs: Population Division [Electronic resource]. – Mode of access: <https://population.un.org/wpp/>. – Date of access: 08.06.2023.
 23. Fertility, Mortality, Migration, and Population Scenarios for 195 Countries and Territories from 2017 to 2100: A Forecasting Analysis for the Global Burden of Disease Study [Electronic resource] / S.E. Vollset [et al.] // *The Lancet*. – Vol. 396, iss. 10258. – Mode of access: [https://www.thelancet.com/journals/lancet/article/PIIS0140-6736\(20\)30677-2/fulltext#%20](https://www.thelancet.com/journals/lancet/article/PIIS0140-6736(20)30677-2/fulltext#%20). – Date of access: 08.06.2023.
 24. Peron, J. Exploding Population Myths [Electronic resource] / J. Peron. – Mode of access: <https://www.fraserinstitute.org/sites/default/files/ExplodingPopulationMyths.pdf>. – Date of access: 09.06.2023.
 25. Heather Alberro – Why We Should Be Wary of Blaming "Overpopulation" for the Climate Crisis [Electronic resource]. – Mode of access: <https://braveneweuropa.com/heather-alberro-why-we-should-be-wary-of-blaming-overpopulation-for-the-climate-crisis>. – Date of access: 09.06.2023.
 26. Sokrashcheniye chislennosti naseleniya Zemli – tsel' global'noy demograficheskoy politiki [Reducing the Earth's Population Is the Goal of Global Demographic Policy] [Electronic resource]. – Mode of access: <https://historiosophy.ru/sokrashhenie-chislennosti-naseleniya-zemli-cel-globalnoj-demograficheskoy-politiki/?ysclid=ljcv08kj8j866946598>. – Date of access: 09.06.2023.
 27. Schwab, K. COVID-19: The Great Reset [Electronic resource] / K. Schwab, T. Malleret. – Mode of access: <http://reparti.free.fr/schwab2020.pdf>. – Date of access: 20.04.2021.
 28. Schwab, K. The Fourth Industrial Revolution [Electronic resource] / K. Schwab. – Mode of access: https://law.unimelb.edu.au/__data/assets/pdf_file/0005/3385454/Schwab-The_Fourth_Industrial_Revolution_Klaus_S.pdf. – Date of access: 09.06.2023.
 29. Klaus Schwab and Prince Charles on Why We Need a Great Reset – Listen to the Podcast [Electronic resource]. – Mode of access: <https://www.weforum.org/agenda/2020/06/the-great-reset-this-weeks-world-vs-virus-podcast/>. – Date of access: 14.06.2021.
 30. Pereslegin, S. Zapret obsuzhdat' vaktsinatsiyu [Prohibition to Discuss Vaccination] [Electronic resource] / S. Pereslegin. – Mode of access: https://www.youtube.com/watch?v=WFI_PzSLadw. – Date of access: 12.07.2021.
 31. Aleksandr Dugin: Manifest velikogo probuzhdeniya [Alexander Dugin: Manifesto of Great Awakening] [Electronic resource]. – Mode of access: <https://izborsk-club.ru/20749>. – Date of access: 24.02.2021.
 32. Did I Say That? [Electronic resource]. – Mode of access: <https://www.theguardian.com/lifeandstyle/2009/jun/21/quotes-by-prince-philip>. – Date of access: 09.06.2023.
 33. Pearce, K. Pandemic Simulation Exercise Spotlights Massive Preparedness Gap [Electronic resource] / K. Pearce. – Mode of access: <https://hub.jhu.edu/2019/11/06/event-201-health-security/>. – Date of access: 11.06.2021.
 34. Lots of Great Vaccination Quotes [Electronic resource]. – Mode of access: <https://vaclib.org/basic/quotes.htm>. – Date of access: 09.06.2023.
 35. National Security Study Memorandum 200: Implications of Worldwide Population Growth for U.S. Security and Overseas Interests, Dec. 10, 1974 [Electronic resource]. – Mode of access: https://pdf.usaid.gov/pdf_docs/PCAAB500.pdf. – Date of access: 09.06.2023.
 36. Civilization [Electronic resource]. – Mode of access: <https://en.wiktionary.org/wiki/civilization>. – Date of access: 01.09.2022.
 37. Perevod: s latinskogo na russkiy [Translation: From Latin to Russian] [Electronic resource]. – Mode of access: <https://translate.academic.ru/lex/la/ru/>. – Date of access: 01.09.2022.
 38. Kharari, Yu.N. 21 urok dlya XXI veka [21 Lessons for the 21st Century] / Yu.N. Kharari. – Moscow: Sindbad, 2019. – 416 p.
 39. Izmeneniye klimata: posledstviya, smyagcheniye, adaptatsiya [Climate Change: Consequences, Mitigation, Adaptation]: Educational and Methodical Complex / M.Yu. Bobrik [et al.]. – Vitebsk: VGU im. P.M. Masherova, 2015. – 424 p.
 40. The World's Smartest Artificial Intelligence Just Made Its First Magazine Cover [Electronic resource]. – Mode of access: <https://www.cosmopolitan.com/lifestyle/a40314356/dall-e-2-artificial-intelligence-cover/>. – Date of access: 01.09.2022.
 41. Fromm, E. Escape from Freedom / E. Fromm. – New York: Avon Books, 1965. – 334 p.
 42. Valuyeva, Ye.A. Effekt Flinna: obzor sovremennykh dannykh [The Flynn Effect: Overview of Current Data] / Ye.A. Valuyeva, S.S. Belova // *Psikhologiya. Zhurnal Vysshey shkoly ekonomiki*. – 2015. – Vol. 12, No. 4. – P. 165–183.
 43. Bark, I. Zhertvy ekologicheskoi chistoy energii: skol'ko ptits gibnet ot vetrogeneratorov [Victims of Eco-Friendly Energy: How Many Birds Die from Wind Turbines] [Electronic resource] / I. Bark. – Mode of access: <https://www.techinsider.ru/science/579664-vyyasnilos-skolkoptic-gibnet-ot-vetrogeneratorov/>. – Date of access: 01.09.2022.
 44. Dams and Development: A New Framework for Decision-Making: The Report of the World Commission on Dams [Electronic resource]. – Mode of access: https://archive.internationalrivers.org/sites/default/files/attached-files/world_commission_on_dams_final_report.pdf. – Date of access: 01.09.2022.
 45. Nachala sovremennogo yestestvoznaniya [Beginnings of Modern Natural Science] [Electronic resource]. – Mode of access: <https://estestvoznanie.academic.ru/396/ДНК>. – Date of access: 01.09.2022.
 46. Gul'karov, I. Kakova rol' gravitatsii vo Vseleynoy [What Is the Role of Gravity in the Universe] [Electronic resource] / I. Gul'karov. – Mode of access: <https://www.kontinent.org/article.php?aid=5335a2abd1aa7>. – Date of access: 01.09.2022.
 47. Kletka [Cell] [Electronic resource]. – Mode of access: <https://www.krugosvet.ru/enc/biologiya/kletka>. – Date of access: 01.09.2022.
 48. The Heart & Blood Vessels Explained [Electronic resource]. – Mode of access: <https://www.hirslanden.com/en/international/focus/heart/heart-bloodvessels.html>. – Date of access: 01.09.2022.
 49. Tesla, N. Dnevnik: ya mogu ob"yasnit' mnogoye [Diaries: I Can Explain Many Things] [Electronic resource] / N. Tesla. – Mode of access: <https://djvu.online/file/3HzTrQW1PMYse>. – Date of access: 10.06.2023.
 50. Nosovsky, G. Raskol Imperii: ot Groznogo-Nerona do Mikhaila Romanova-Domitsiana [Splitting of the Empire: from Grozny-Nero to Mikhail Romanov-Domitian] [Electronic resource] / G. Nosovsky. – Mode of access: <https://iknigi.net/avtor-bleb-nosovskiy/70229-raskol-imperii-ot-groznogo-nerona-do-mihaila-romanova-domiciana-bleb-nosovskiy/read/page-1.html>. – Date of access: 10.06.2023.
 51. Zabarinskiy, P.P. Stefenson [Stephenson] [Electronic resource] / P.P. Zabarinskiy. – Mode of access: <https://coollib.net/b/190592-petr-petrovich-zabarinskiy-stefenson/read>. – Date of access: 10.06.2023.
 52. Polnaya entsiklopediya nashikh zabluzhdeniy [A Complete Encyclopedia of Our Misconceptions] [Electronic resource]. – Mode of access: <https://belibra.ru/Polnaya-entsiklopediya-nashikh-zabluzhdyeniya.696.html>. – Date of access: 10.06.2023.
 53. Ladd, B. Autophobia: Love and Hate in the Automotive Age [Electronic resource] / B. Ladd. – Mode of access: <https://clck.ru/34wTcz>. – Date of access: 10.06.2023.
 54. Heidegger, M. The Question Concerning Technology and Other Essays [Electronic resource] / M. Heidegger. – Mode of access: <https://www.thetedkarchive.com/library/martin-heidegger-the-question-concerning-technology-and-other-essays>. – Date of access: 10.06.2023.
 55. Berdyayev, N. The Destiny of Man [Electronic resource] / N. Berdyayev. – Mode of access: https://archive.org/details/destinyofman000berd_p5x7/page/n5/mode/2up. – Date of access: 10.06.2023.
 56. Spengler, O. Man and Technics: A Contribution to a Philosophy of Life [Electronic resource] / O. Spengler. – Mode of access: <https://archive.org/details/mantechnicscontr0000spen/mode/2up>. – Date of access: 10.06.2023.
 57. Nicene Creed [Electronic resource]. – Mode of access: <https://www.britannica.com/topic/Nicene-Creed>. – Date of access: 10.06.2023.
 58. Tcennost' [Value] [Electronic resource]. – Mode of access: https://sociology_encyclopedia.academic.ru/1194/ЦЕННОСТЬ. – Date of access: 21.06.2021.
 59. Fromm, E. To Have or to Be? [Electronic resource] / E. Fromm. – Mode of access: <https://archive.org/details/dli.ernet.236788/page/n111/mode/2up>. – Date of access: 10.06.2023.
 60. Heidegger, M. Nietzsche's Word: "God Is Dead" [Electronic resource] / M. Heidegger. – Mode of access: <https://cupdf.com/document/heidegger-nietzsches-word-god-is-dead-holzwege.html?page=1>. – Date of access: 10.06.2023.
 61. Heidegger, M. Nietzsche [Electronic resource] / M. Heidegger. – Mode of access: <https://tuxdoc.com/download/heidegger-martin-nietzsche-vols-i-amp-ii-harperone-1991.pdf>. – Date of access: 10.06.2023.
 62. Garanina, O.D. Krizis dukhovno-nravstvennykh tsennostey kak vyrazheniye global'nogo krizisa [The Crisis of Spiritual and Moral Values as an Expression of the Global Crisis] / O.D. Garanina // *Vestnik Moskovskogo gosudarstvennogo universiteta lesa – Lesnoy vestnik*. – 2011. – No. 2 (78). – P. 168–172.



UDC 008.2

Global Ritual Sacrifice and Establishment of Engineering Civilization as Alternative Scenarios of the Future

A. Unitsky^{1,2}
Dr. of Philosophy
in Information Technologies
(Transport)

E. Petrov²

¹ Astroengineering Technologies LLC,
Minsk, Belarus

² Unitsky String Technologies Inc.,
Minsk, Belarus

”

An attempt is made to interpret the global processes taken place in the first quarter of 21st century through the sacrifice matrix as one of the fundamental ritual practices during the formation of civilizations. The main ways to understand the sacrifice which are described in the literature are analyzed. The article contains highlighted and systematized key meanings that some researchers attribute to sacrifice rituals, as well as several patterns of historical transformation of interpretation of this phenomenon. The authors have identified two approaches to active transformation of reality which have emerged and continue to develop in different cultures: ritual and engineering ones. The risks when political and economic elites appeal to ritual are shown. There is reasoned necessity of transfer to civilization structure based on engineering technologies. The prospects of development arising from such a transfer, including industrialization of near space, creation of new systems for settlements, energy sector, agriculture and land transport, are reviewed.

Keywords:

civilization, elites, engineering, rationality, ritual, sacrifice.

Introduction

When one speaks of human sacrifice, images of the bloody rituals of antiquity come to mind. It is believed that modern civilized and humane society has long ago condemned such savage practices. And that nothing of the kind can happen in the 21st century, unless as a gruesome crime. At the same time, the tendencies that are being discovered in the world and that lead, under certain events, to the most massive extermination of people in history in the course of nuclear war [1], can hardly receive a deeper elaboration than that through the matrix of sacrifice. No pragmatic approaches justify such a scenario. Only irrational faith can give hope for the establishment of a more perfect and just world order of the future as a result of total destruction.

The analysis carried out in this study demonstrates that human sacrifice has been and remains one of the main tools for maintaining the balance of the world system as well as an integral element of any significant civilizational shifts. It is such a shift that is taking place today – in the 20s of the 21st century. If we assume that it goes on in the same direction and in the same logic, in which all previous global transgressions have been made, the scale of sacrifice shall become monstrous. We can talk about disappearance (depopulation) of the majority of the Earth's population. Consideration of the ritual of human sacrifice as a system-forming and system-regulating tool of modern civilization allows us to make an attempt to search for alternative scenarios and models of its further development.

Origin of Sacrificial Ritual

According to the church, sacrifice is a sign of adoration of the deity, a sign of gratitude and submission. The origins of the ritual are found in primitive peoples. One of the most ancient forms of sacrifice is considered to be the so-called sacrifice of all first, i.e., sacrificing the first hunting prey, the first fruits and the first litter of herds as a sign of adoration to the supreme being. Outside the church tradition, the theory of gift, connected with the animistic concept of the origin of religion, is widespread. Such views were already expressed by the enlighteners of the 18th century, who believed that primitive people sought to please and propitiate the spirit or god, whom they represented by analogy with themselves and therefore offered him what the spirit or deity, as they thought, needed: food, sometimes clothes, weapons, jewelry or utensils [2].

There are other points of view on the origin of sacrifices. Some believe that originally sacrifice was not a gift or offering of anything to the god at all. Sacrifice was a form of communication between the members of the clan and the deity of the clan. The slaughter and eating of the sacrificial animal was a joint clan meal; the deity or totem of the clan was invited to participate in it. The god and his worshippers, as R. Smith wrote, usually ate and drank together, and by this sign their copartnership was declared and sealed. The most ancient sacrifice is the killing and eating of a totemic animal. From this the idea is developing that any sacrificial animal is sacred [2].

In atheistic literature, sacrifice is often interpreted through the theory of deception. It is argued here that "the custom of sacrifice was introduced by deceitful priests who invented this way of profiting at the expense of simple-minded people for their own profit. They demanded from tribe members to bring food or various useful objects under the pretext that it was necessary for spirits, ancestors and gods. This view was expressed by publicists and philosophers of the 18th century, and in modern times it was presented in a particularly simplified and crude form by the German popularizer of atheism H. Eildermann, who tends to vulgar materialism" [2].

Summarizing the described approaches, we can distinguish several meanings traditionally invested in the rite of sacrifice:

- 1) gratitude and submission to a higher power;
- 2) gift brought to the higher powers in order to receive certain benefits from them, i.e., a kind of exchange;
- 3) fixation and maintenance of the established social hierarchy as well as the relationship between society and the deities it worships;
- 4) deception by the priesthood or ruling class to achieve their own pragmatic goals.

At the same time, the abovementioned can be relevant to a given situation both separately and together. It can also be assumed that as society becomes more complex, moving from the tribal system to the class system, the religious aspects of sacrifice (the above points 1 and 2) become less and less significant in comparison with the regulative-pragmatic ones (points 3 and 4). "The further the process of internal decomposition of the primitive community went, the more the contradictions of interests of, on the one hand, wizards, sorcerers, fortune-tellers, shamans, later priests and, on the other hand, the masses of "common people" were revealed in it. This is where deceit and extortion began

to appear, and the further, the more so. Although the attempts of some former authors, especially propagandists-atheists, to reduce all sacrifices to "priestly deception" suffer from extreme simplification of the problem, the facts of such deception cannot be denied. After all, it is not without reason that one of the prominent modern ethnographers, the American P. Radin, studying the early forms of religion, came to the conclusion that all these primitive beliefs, magical practices, sacrifices and so on are the work of "religious formulators" – shamans and priests, for whom religion is a tool used for economic exploitation. It was to a large extent so. Siberian shamans, treating people or livestock, demanded blood sacrifices to propitiate the spirits; they took part of the sacrificial meat for their own benefit. Some shamans lived by this, not having their own household" [2].

It is generally believed that "the custom of sacrifice – as an essential component of religious cult – developed from several different roots, connected with different aspects of the life conditions of primitive society: from the specificity of the primitive hunting economy (and later the agriculture and cattle breeding that replaced it), from the structure of the primitive community itself, from intertribal clashes, from funerary customs" [2].

From the psychological point of view, the prerequisites for the emergence of human sacrifices can be seen in the specifics of humans' perception of their own mortality and the death of their neighbors. The beginning and the end, birth and transition to another world have always been beyond the direct influence of human. Murder (whether it is the killing of an animal or human beings) is a violation of the existing order of things. In realizing this, already on a primitive level, one should develop an idea of the criminality of such an action, which seems to encroach on the subject world, organized by some other forces, higher and more powerful in relation to a human. And if this sense of crime arises, then the fear of punishment also appears. Probably, the rite of sacrifice was initially supposed to help to avoid punishment. That is why the first hunting prey, the first litter and the first harvest were sent to the altar. This was a kind of a bribe to the policeman or a tax to the ruler at the level when natural incomprehensible and powerful elements were perceived as such.

In a similar vein is the reasoning of the French philosopher G. Bataille [3], who analyzes sacrifice through the categories of subject-object relations as well as transcendence and immanence. The essence of these relations "is the removal of the object through its destruction from the relations of consumption. The object is endowed with exceptional

qualities in relation to other things, which not only reproduces the original dualism but also represents it or even creates it at the level of relations with the sacred and social relations" [4]. In this sense, the coordinated terrorist suicide attacks of September 11, 2001 were an act of sacrifice in the precise sense of the phenomenon according to Bataille as bearing the counter-meaning of the total trend of Americanization and globalization. An important aspect of G. Bataille's definition is that the sacrifice is taken away as a useful thing, i.e., included in relations of production and distribution, and hence of power [4].

In the process of sacrifice, according to Bataille, human is able to return to the state of immanence – identification with nature and, consequently, with the sacrifice. By removing the victim from the world of objects and endowing it with special qualities, the relation of subordination between the murderer and the murdered, which arises in the context of consumption, is dissolved. The human being becomes equal to the sacrifice, like an animal, because "when one animal eats another is always the fellow creature of the one that eats. It is in this sense that I speak of immanence. I do not mean a fellow creature perceived as such, but there is no transcendence between the eater and the eaten; there is a difference, of course, but this animal that eats the order cannot confront it in an affirmation of that difference" [3]. On the other hand, in addition to returning the person to the state of immanence and along with the attempt to propitiate the real master of the sacrifice, the relationship of the sacrificer with this master was apparently established.

If we consider sacrifice not only in its utilitarian sense as a waste, as G. Bataille did, but also in its religious dimension as a gift, then the giver occupies a higher position than the victim. In such a ritual, power is enacted and consolidated. And the highest power available to human, in the primitive dimension, was to be consolidated as dominion over the life of another person. In this action in honor of the deity, human comes as close to the deity as possible. Unable to give life and fully dispose of it, forcibly terminating it to please its true master in the rite of sacrifice, the murderer, as it were, participates in the act performed by the deity, comes as close as possible to the deity, to the point of self-identification with him. G. Bataille describes such an attitude in the "priest – sacrifice – deity" connection as follows: "When the offered animal enters the circle in which the priest will immolate it, it passes from the world of things which are closed to man and are nothing to him, which he knows from the outside – to the world that is immanent to it,

intimate, known as the wife is known in sexual consumption (consummation charnelle). This assumes that it has ceased to be separated from its own intimacy, as it is in the subordination of labor. The sacrificer's prior separation from the world of things is necessary for the return to intimacy, of immanence between man and the world, between the subject and the object.

The sacrificer needs the sacrifice in order to separate himself from the world of things and the victim could not be separated from it in turn if the sacrificer was not already separated in advance. The sacrificer declares: "Intimately, I belong to the sovereign world of the gods and myths, to the world of violent and uncalculated generosity, just as my wife belongs to my desires. I withdraw you, victim, from the world in which you were and could only be reduced to the condition of a thing, having a meaning that was foreign to your intimate nature. I call you back to the intimacy of the divine world, of the profound immanence of all that is" [3]. Thus, the sacrifice, being excluded from the cycle of consumption, returns the victim to the state of harmony with the world as a certain order, and at the same time it consolidates the relationship of the victim with the entity that established this order by removing the contradiction between the subject and the object, acting as a mediator between the human and the divine and, consequently, being the basis for building and consolidating the hierarchical order within society.

In the book "Totem and Taboo" S. Freud hinted that not only sacrifice but culture in general originated from the guilt felt by primitive human for killing his own father. According to the Austrian psychoanalyst, religion and culture arose from the fear and trembling caused by the killing, cutting, roasting and devouring of the most precious thing a creature endowed with faith and reason can have – its own parent [5]. In his conclusion Freud relied not only on the associations of the neurotics he analyzed. From the works, in particular, of J. Frazer, it is known the tradition of sacrifice of the old king – the leader, who was unable to further ensure the welfare of the people ("Akela has missed"), was solemnly killed and replaced by a young one. The peoples of the Far North, until recently, left infirm old men in the taiga and tundra to be torn apart by beasts [6].

Apparently, the edifice of any hierarchically organized society, i.e., a society divided into estates, classes or strata, between which relations of domination and subordination are established, is constructed around the ritual of sacrifice. Some ethnographic studies suggest this. In particular, New Zealand anthropologists J. Watts and R. Gray from the University

of Auckland studied the practice of human sacrifice among representatives of 93 Austronesian nationalities and cultures living on a large territory from Madagascar to Easter Island. The scientists tried to establish a connection between the prevalence of bloody fratricidal rituals and the form of political organization in the community. They divided them into three groups:

- societies of equality;
- societies where power is elective;
- societies where power is assigned to a particular group and then passed on through inheritance.

"Human sacrifices took place in 40 of the 93 cultures studied (43 % of the total), including five of 20 (25 %) egalitarian, 17 of 46 (37 %) societies with a "temporal" and 18 of 27 (67 %) with an "innate" hierarchy" [7]. The difference was so significant that J. Watts and R. Gray had to assume that human sacrifice in primitive tribes was a tool to consolidate the dominance of some over others, and the introduction of bloody practices correlates with the transition of society from a political model of equality to one or another type of hierarchical organization.

Freud's conjecture and anthropologists' data suggest that sacrifice, at least historically, is the basis for the formation of any complex social system. Relationships with higher powers and subordination within groups are built around bloodshed. Blood (or bloodless sacrifice) fixes the most significant decisions – the beginning of hunting or military campaign, coronation, wedding. The sacrifice marks all major stages in the life of a person and a community – birth, initiation, the beginning of sowing or harvesting, death and funeral. In particular, the famous gladiatorial fights arose from a tradition associated with burial. "Before becoming an infamous circus spectacle, the "games" of gladiators were – first among the Etruscans and then among the Romans themselves – a type of funerary sacrifice" [2].

A superficial look at civilizations, or rather at the way they represent their own emergence, gives confirmation to the assumption of the fundamental role of sacrifice in the processes of cultural genesis.

"The first human sacrifice in the history of Hinduism was the first man Purusha. The Rigveda, one of the world's oldest religious texts, composed in the 2nd millennium B.C., tells how the gods sadhyas (lower gods) and rishis (divine sages) sacrificed Purusha and created the world from him...

One of the Rigveda's hymns describes in detail how the four varnas of the Indian caste society were created from the body parts of the first man: the Brahmins, of course,

were born from the head of Purusha, the Rajanya, or Kshatriya warriors, from the hands, the Vaishya traders from the hips, and finally the Shudra servants from the feet. From the other parts of the body the sky, sun, earth, wind and other useful elements of existence were created. The airspace was created from the navel, and the gods Indra and Agni from the mouth. The spirit of Purusha, from which, strange as it may seem, such a material body as the moon was made, was not wasted. Lastly, from his ear, on the contrary, such abstract concepts as the sides of the world were created. Besides, other immaterial realities have also sprung from this sacrifice" [8].

The Chinese trace the lineage of everything back to their version of the first man named Pangu. Giant, he divided and fixed heaven and earth in their places and then lay down to rest to perish and give rise to all that surrounds us. The air from his chest became wind. The flesh became soil, the bones became stones, the hair on his body became plants, the hair on his head became stars, the sweat became rain, the eyes became the sun and the moon, the voice became thunder, and the tears became the waters of the Yellow River.

The amazing myth of Prometheus, who gave fire to people and thus sacrificed himself, forms one of the foundations of ancient Greek civilization. Further, Christian civilization considers its beginning to be the God's sacrifice of his consubstantial son, Christ. This atones for the sins of humankind and opens the possibility of salvation and eternal life. Finally, when Christianity slowly begins to lose its position in Europe, when a new version of the great social model – New European civilization, capitalism, consumer society – is formed, then F. Nietzsche speaks of the death of God as the foundation on which the new world is erected. "God is dead! God remains dead! And we have killed him! How can we console ourselves, the murderers of all murderers! The holiest and the mightiest thing the world has ever possessed has bled to death under our knives: who will wipe this blood from us? With what water could we clean ourselves? What festivals of atonement, what holy games will we have to invent for ourselves? Is the magnitude of this deed not too great for us? Do we not ourselves have to become gods merely to appear worthy of it? There was never a greater deed – and whoever is born after us will on account of this deed belong to a higher history than all history up to now!" [9].

In the world of economics and politics, the death of God, his sacrifice, was embodied in the secularization of church wealth. Everywhere, land and worldly power were taken away from clerics, up to the physical murder of priests,

the destruction of churches or the rebuilding of churches into planetariums and vegetable stores, as was the case, for example, in the USSR. Objectively, the ritual murder of God was accompanied by a mass of human sacrifices at the hands of the Holy Inquisition as well as in religious, civil, colonial and later ideological wars. Throughout human history, almost until the end of the first quarter of the 21st century, sacrifices (including human ones) have always occupied an important place among social practices and events.

Ritual Murder in Antiquity

In popular culture, human sacrifice is, for example, the footage of a severed Indian head rolling down the steps in the valley of the Lambayeque pyramids and falling into a pile of other heads. Others think of the story of the Old Testament Abraham, who was ordered by God to kill his only beloved and long-awaited son. Admirers of ancient culture will imagine Sophocles' description of the ritual murder of Priam's daughter Polyxena in honor of Achilles, who had fallen in battle. All these repeatedly quoted artistic images have confirmation in historical science. Archaeological excavations testify: traditions of human sacrifices arise almost simultaneously with the emergence of *Homo sapiens* as a species. There are reasons to believe that cultic killing of their own kind was practiced even by Neanderthals.

"The remains of about 20 Neanderthals have been found in the Krapina Cave in Croatia, with bones charred and shattered and skulls badly damaged. Some scientists are inclined to think that the inhabitants of the cave were not just treating the brain but committed a religious ritual and that two dozen Neanderthals were killed for ritual purposes. Such rituals in new age savages are usually explained by the desire to join the life force of the enemy. And the crushing of bones could be related to an attempt to prevent resurrection.

A similar finding was made on the island of Java where in the sand and gravel deposits, the age of which is over 100,000 years, were found 11 skulls with crushed facial parts but without skeletons. It is noteworthy that neither lower jaws nor teeth in the skulls were also found.

Scientists from the University of Michigan S. Garn and W. Block, having studied the properties of human meat, came to the conclusion that any cannibalism, as a rule, should be regarded as ritual, because humans are very much inferior to herbivorous animals in terms of nutrition. Neanderthals lived in times when there was no shortage of either mammoths, antelopes or fat and tasty rodents,

and people hardly had to suffer from hunger. Therefore, even if once some particularly hungry Neanderthal decided to eat his own kind, the mass finding of perforated skulls and charred human bones could be explained more by ritual reasons.

And in any case, ritual reasons explain the discovery made in the vicinity of Rome, in the grotto on the mountain Monte Circeo. They found the skull of a Neanderthal with almost completely removed occipital bone. The owner of the skull had been killed by a blow to the temple. Bones of bison and deer were piled up in the corners of the grotto, and a circle of stones was laid out around the skull. V. Kabo writes: "There is a speculation that the animal bones are the remains of a funerary feast and that the complex as a whole is the result of a ritual murder committed 55,000 years ago" [8].

Mass graves of remains of people who died violently under mysterious circumstances have been found in various places on the planet. Not only primitive savages but also representatives of developed civilizations of the Ancient World were not strangers to ritual murder. Egypt, China, India, Western Asia, Phoenicia, Ancient Greece and Rome, pagan Europe and America – everywhere in one form or another traces of atrocities justified by some tradition and relevant considerations are found. However, most likely, these seem to be atrocities only today. Back then, on the contrary, sacrifice was portrayed as a virtue. In many cultures people voluntarily went to death for one good or another. In Egypt, where the remains of hundreds of people who did not die of their own accord were found near the tombs of the pharaohs, "until the end of the Old Kingdom (approximately until the 23rd century B.C.) no harm threatened the deceased Egyptians and no one even needed the patronage of the gods behind the coffin – they are not depicted on the walls of ancient tombs. The human who managed to get into the afterlife by any means and by any injustice, remained forever to lead there a trouble-free existence. Therefore, it cannot be excluded that the servants voluntarily followed their masters, preferring the short-lived earthly life to eternity behind the coffin, even if it meant dying – because the second such opportunity might not have been given again" [8]. In India for a long time a wife had to follow her dead husband to the pyre. If this did not happen, such a woman became an outcast and her life was unenviable.

The rituals, impressive in their luxury and scope, were carried out, judging by the findings of scientists, in Sumer. "The noble Sumerians, equipping themselves for the final journey, were not going to deny themselves any earthly pleasures. Their tombs, sometimes consisting of several rooms,

are spacious rooms made of brick and stone, which was brought from dozens of kilometers away. Archaeologists find here luxury items: musical instruments, sets of board games like checkers, vases, animal figures sculpted from precious stones... Next to the men lie daggers of fine work, patterned spears... Noble ladies took with them a huge amount of jewelry and cosmetics... And naturally, the Sumerian rulers did not want to do in the afterlife without their servants and courtiers. But the archaeologists were amazed by the fact that these servants, apparently, dared to accompany their masters voluntarily. There are no signs of violent death on their bodies, and they are buried, as a rule, in the most relaxed poses.

The tombs of the kings of the First Dynasty of Ur (who ruled in the middle of the 3rd millennium B.C.) resemble not a tomb but feast halls, which the breath of death touched unexpectedly for all present. It seems that the musicians continued to play harps until the last moment, and the ladies – to entertain their queen with cheerful conversation. Moreover, these ladies were not slaves thrown into the grave for the afterlife service but dearly dressed women, decorated with gold and stones, apparently rich and noble. There is a version that the servants and courtiers of Sumerian rulers voluntarily descended into luxurious crypts, in order to continue their prosperous existence in the next world. They took a narcotic poison, which relieved them of the anguish of death, and fell asleep forever to the music of the same voluntary suicide-musicians, or they were stabbed in their sleep with an instant and painless blow of a stiletto" [8].

The above is only part of the diverse history of human sacrifice in antiquity. Official science, or rather mass ideology, inculcates the notion that such rituals are a thing of the past. That the religions of the world have moved from real bloodshed to symbolic forms of such action. And that today practices like the one described above, if any, exist only as a horrifying form of deviation. This is the version accepted by most. There is also an alternative view. Its meaning is that human sacrifice has been and remains a real and essential instrument of legitimizing the power of the ruling estates as well as a gift and a way of receiving goodwill from the higher powers to which they are subordinated. Naturally, the forces themselves bear little resemblance to archaic gods, and the instruments of murder are not the copper knives of priests. However, this does not change the essence. Sacrifice, as some researchers believe, has been and remains the fundamental beginning of any culture and civilization, including modern Western civilization, which claims to be a global system of values and guidelines.



After the loss of religious dimensionality, sacrifice should be seen in three other dimensions. At the level of the collective and individual unconscious – as an archetype ordering experience. At the level of individual and collective consciousness – as a kind of substitute algorithm that allows redirecting violence from significant and valuable objects to less important ones. And at the operational level – as a regulatory mechanism that holds, consolidates and contributes to the preservation of the existing social order.

Sacrifice Is an Unbroken Tradition

The weakening significance of sacrifice as a ritual and filling in the relationship between human and the higher powers does not diminish the importance of sacrifice in the formation and maintenance of the social order foundations. This includes the consolidation of the social hierarchy established at this or that stage. It is through sacrifice as a form of appropriation and transfer of property that some people can rise above others at a fundamental level. It is also through sacrifice that the human species asserts itself as something superior to animals, plants and other forms of life.

"Ritual sacrifice is no less a part of contemporary society than it was ancient Greek society. One important difference is that while the ancient Greeks may or may not have actually engaged in human sacrifice, contemporary capitalist society definitely does," argues Hampton University researcher N. Partyka [10]. Sacrifice in the capitalist system of consumer society, as in previous formations, is a way of maintaining hierarchy. In this case, the basis of its construction is the dichotomy of rich and poor, within which there are many levels and sublevels from poverty to superstates of the ruling "elites" in the world.

"The Communist Manifesto" by K. Marx and F. Engels says: "The history of all hitherto existing societies is the history of class struggles. Freeman and slave, patrician and plebeian, lord and serf, guild-master and journeyman, in a word, oppressor and oppressed, stood in constant opposition to one another, carried on an uninterrupted, now hidden, now open fight, a fight that each time ending in a revolutionary reconstitution of society at large, or in the common ruin of the contending classes" [11].

Despite the fact that modern sociology has a plethora of approaches alternative to the Marxist's one to the understanding of society and the transformations that drive

its historical changes, this thesis is difficult to dispute in and of itself. Today, as at the dawn of humanity, there is a multilevel hierarchy in which higher positions are occupied at the expense of those below, who are literally or figuratively sacrificed for the sake of profit, status or power. Sacrifice is conceptualized here in other categories, but its essence remains the same as it was long ago.

"Capitalist society chooses, almost from birth, those it will subject to the kinds of social and material pressures that drive people to crime in order to meet their needs, either for material resources or for social status. Then, after some of these people succumb to the pressures and incentives arrayed before them, capitalists utilize their power to organize public rituals of sacrifice, or as we call it, the criminal justice system. Capitalist elites intentionally disinvest in public social services, e.g. education and healthcare, then when people find it impossible to live with dignity, they resort to any means necessary to provide. Capitalist elites criminalize this behavior, then apprehend, try, and if convicted, punish those who refuse to accept the social station assigned them. One grotesque example of the comedy of guilt in this connection is the widespread criminalization of homelessness" [10].

Just as it was customary in ancient rites, the victim must accept its fate. It must step to the altar itself. To do this, a much more elaborate and costly comedy is played out than the ancient Greeks' one, as example (although they were quite inventive). The problem the Greeks had to face "was that the idea of a cow, sheep, ram, or pig consenting to be sacrificed by a human in the name of a God is laughable. Humans and animals possess no reliable means of communicating, especially for such a complex notion as ritual sacrifice. Moreover, even if a machine enabled humans and animals to communicate, it is by no means clear that we could sufficiently explain to them notions like God and ritual sacrifice for them to make a suitably informed choice that could alleviate humans' guilt. Thus, the Greeks made use of the comedy of innocence to resolve their feelings of guilt at killing an animal they have raised, and have a relationship with, and stands in symbolically for humans. As we saw above, this process would occur at the beginning of the sacrificial ritual. The human participants would stand in a circle, water would be brought in a vessel, and there would be a ritual washing of hands. Water would then be offered to the animal, or perhaps sprinkled on its head, inducing the animal to make a gesture that the humans could interpret as it giving its assent to be sacrificed. In another variation of this process a select few animals might be

arrayed around the altar, upon which were placed some food items cows would find hard to resist. The first animal to move in for a taste of the treats displayed before it could then be interpreted as assenting to be sacrificed. Since the animal could be said to go "voluntarily" to the sacrificial altar any feelings of guilt the Greeks had would be assuaged" [10].

The consent of the victim is necessary to alleviate or remove the guilt of the one who commits the murder. More importantly, without it, the ritual cannot be conceptualized in terms of giving. In order to give something, that something must belong to the giver. The consent of the victim to go to slaughter is the giving of oneself to another, who is giving the life of an alien as belonging to him. Other mechanisms for acquiring a right to someone else's life are purchase or capture. They were also common. For example, among the Khonds "for a long time there was a rite of voluntary sacrifice to increase the harvest. The community bought a person's consent to die, and sometimes parents sold a child for this purpose, after which he could live for many years and even marry and have children. But when it became necessary to take care of the crops, the victim was consecrated, identified with a deity, and then drugged with opium and strangled. The body of the victim was cut into many pieces, which were buried in the ground all over the surrounding fields" [8]. This was also done with captives. For example, "the warlike Aztecs in Mexico brought to a great extent the practice of human sacrifices to their cruel gods – Huitzilopochtli and Tezcatlipoca. In order to have a constant supply of human material for these sacrifices, they waged frequent wars with their neighbors for captive taking. These sacrifices were required especially for the "sun" god Tezcatlipoca. It was believed that the sun, without receiving enough of them, would cease to shine brightly. The Spanish conquistadors who were not softhearted people themselves were amazed at the sight of a tall pyramid of human skulls in Tenochtitlan – the remains of sacrificed..."

In essence, the entire history of the Israelites' wars of extermination for the possession of Palestine in the late 2nd and early 1st millennia B.C. falls into this category of cruel military customs – extermination of enemies for the glory and at the request of their god. In the Bible these wars are described as a direct command of Yahweh, who, ordering his people to conquer city after city, insistently repeated the requirement not to leave alive a single person, regardless of sex or age (Joshua, VI, 20; X, 28–43; etc.). Such mass human sacrifices, made at the unconditional demand of God, the world history, it seems, has not yet known" [2].



Captives were killed both directly to please the higher powers and as part of burial rituals. On the territory of China in Anyang a burial of local rulers was found with a total area of about 380 m². The remains of hundreds more people were found near the remains of the rulers. Apparently, servants. "And outside the whole cemeteries were stretched: graves of decapitated prisoners of war with their hands tied behind their backs. Thousands of their heads were buried in separate pits.

The fact that the victims were mostly prisoners of war is evidenced by the analysis of their remains: while the sponges themselves, found in ordinary graves with equipment and weapons, were characterized by anthropological homogeneity, in the sacrificial burials people of various nationalities can be found. Slave labor was not yet massively used at that time. Apparently, guarding and feeding many forced laborers was not always profitable, but it was always dangerous. There is evidence that captives could be used for some labor-intensive one-time work: construction of giant tombs, elimination of floods' consequences, but then sooner or later they were killed in order to please the ritual, and perhaps for lack of need. Captives could also be involved in spring agricultural work, after which they participated in fertility rites and were sacrificed as part

of the ritual of "sacred marriage". The following inscription from the Shang era is known: "Wang commanded many Qians to perform fertility rites in the fields" [8].

However, in a modern humane society, neither people trafficking nor the taking of captives as property on the battlefield are common. Therefore, human sacrifice can only be placed at the disposal of the ritualist voluntarily, for which modern capitalist society has created amazingly ingenious tools and mechanisms. To begin with, it is necessary for people to accept only a few statements as unconditionally true. The education system, influential international organizations like the UN as well as the mass media and mass culture work harmoniously on this. The truths are roughly as follows:

- democracy is the best possible form of political organization;
- capitalism is the most perfect economic system;
- ecology is the supreme value of the modern world;
- human habits and actions have a decisive influence on the state of ecology;
- to restore ecological balance in the world, it is necessary to reformat the nature of production and consumption while preserving capitalism and democracy.

What can unquestioning acceptance of these ideas lead to?

1. Power should remain alternating through elections, which, with an eye to capitalism, means that power is controlled by capital, which finances any election campaigns and, as a consequence, is able to put the right people in key positions to achieve the desired results.

2. Capital should continue to accumulate in the hands of a small group of people who gain more and more real power, which is enshrined in appropriate agreements and legitimized through democratic procedures.

3. Big capital is given the opportunity to dictate its terms and impose unfavorable rules of the game for competitors through the environmental agenda with various quota systems, restrictions and global eco-technological trends, which require additional production costs and thus prevent new players unable to withstand environmental burdens from entering the markets.

4. People should massively refuse to own anything as an unsustainable way of consumption. The objects of the material world must be exploited as intensively as possible and incorporated into recycling systems. Food, clothing, transport, housing, entertainment – everything should have the character of industrial capitalist flow production, in which people will use an object only for a short time and only partially, and then return it to the production-consumption chain. Food waste, worn-out clothes, worn-out cars – everything should be recycled, as if rented out. Consumption and production should become inseparable elements of a single system in which the human being is an object among other objects.

5. Classical capitalism (as described by K. Marx) exploited human labor by appropriating the surplus value of the product manufactured. The new capitalism will exploit human as capital – exploitation reaches the absoluteness of its manifestation. The consumer becomes an active accomplice in production. The capitalist will sell the product, thereby compensating for the costs of production, and through recycling systems significantly reduce the costs of raw materials. In classical capitalism, profit equals the market price of the product minus the cost of raw materials, equipment and worker labor. In the new capitalism, labor and raw material costs will be greatly reduced through automation and reprocessing. However, this does not lead to higher profits. On the contrary, due to environmental burdens, social burdens on business and, of course, over-saturated markets, the profits of the new capitalists have a steady downward trend. At the Davos Economic Forum

and in the writings of its head K. Schwab, this model is called inclusive capitalism. The systematization cited by the researchers suggests a number of innovations. "First, profit should cease to be the goal and the main benchmark of business success. Second, companies should go after consumers by lowering prices and thus gradually eradicating poverty and misery. Third, we should abandon the usual notion that corporations are owned by shareholders, who are the main (or even the only) beneficiaries of corporate activities" [12]. It is believed that in such a configuration business will become more flexible. More importantly, such a business will not indirectly, but explicitly take over the functions of the state. The further it goes, the more so. Profit is exchanged for power. And this exchange does not look like a loss for capitalism, on the contrary, it seems to be a more direct road to what we want. People will become part of capitalism not only in body but also in soul, they will accept it wholeheartedly and subordinate themselves to the interests of the corporation, as it is assumed, for example, in the Japanese model of collective capitalism. The corporation will take care of people as a shepherd takes care of a sheep, and with their consent will sacrifice them when it becomes necessary.

Where the ancients situated their comedy at the beginning of their sacrificial ritual, we moderns place our comedy at the end of our sacrificial ritual. Accepting the truths dictated by capitalism as such, people endorse the rules of the game, also accepting the role of the victim (if necessary). At some point, finding themselves homeless and unemployed, finding themselves in the dock or in a trench on the front line, they no longer have any right or will to protest. They lived, consciously or not, as part of that society, of that system, which decided to sacrifice them. So, it was their own choice. The hopeless media agenda and the dystopian image of the future created by Hollywood, the authoritative statements of science about the doom of everything in the world, including even the planets and stars, soften the bitterness of parting with life. Murder continues to be justified and legitimized as a civilized phenomenon rooted in tradition and justified by absolute necessity.

Ritual Consciousness in the Context of the 21st Century

Human sacrifice is one of the historically established forms of violent elimination of people and social groups, a method of killing that is fixed and normalized from the point

of view of a particular civilization. In total, there are five such forms of killing:

1) duel. Legitimized in the context of the dueling code, it is committed in interpersonal relations and serves to achieve personal goals such as honor, revenge, power, etc.;

2) war. It is committed in interstate relations for the sake of pragmatic goals – wealth, fame, power, in fact being the murder of some people by others in the interests of the state;

3) execution. It is conceptualized strictly in the legal field, serves as a punishment and a means of eliminating members of society who pose a danger to other people or to the social formation shaped in this or that period, including the power hierarchy, economic relations, the system of norms, values, etc. It is committed in the relations of the state and the individual; in fact, it is a murder by the state of the individual;

4) terrorist act. As a rule, it has a political or ideological coloring and is a means of expressing the will of a group of people. It arises between states, opposing political or ideological groups or between states and opposing groups of fighters, in essence being the murder of some people by others, sometimes suicide (voluntary self-sacrifice), in the interests of one or another political or ideological doctrine;

5) ritual murder. It is intended to regulate the relations of a person or society with this or that entity accepted as the supreme reality. It arises in the relationship between a person or society and the supreme entity, in essence being the killing of human by human in the interests of the supreme entity to which this killing is dedicated.

The main difference between the described forms of "civilized" murder, as it appears, lies in the space within which it is committed, in the interests it pursues as well as in the specificity of the subjects and objects involved. In reality murder can combine the characteristics of different forms. For example, war can be conceptualized both as a duel and as a sacrifice. Such a big event affects all spheres of social life – from interpersonal relations to relations with divine forces. That is why ideologues try to present almost any war as sacred. Only in this way can murder, as stated earlier, be fully justified in the end. If the murder is committed in the interests of a higher reality, the conscience of the murderer is kind of clear. Sometimes everything is formalized and done as a sacrifice from the beginning. Sometimes the rethinking happens *ex post facto*. Be that as it may, but in all cases wherever the leaders of society decide that someone must be killed, wherever

civilized society deems it necessary to violently put a person to death, everything is framed and conceptualized as a sacrificial ritual.

Ritual can be defined as "a way of behavior, which is a repetition of all actions that once led to a positive result, and the consolidation of these actions (according to K. Lorenz). It is a projection of myth into action. Since it is unknown which action from the whole sequence caused the desired effect, the most effective will be the fullest possible repetition of all of them, which is the case in traditional cultures, the life of the bearers of which is almost completely ritualized. The spread of rituals is as wide as that of myths. Moreover, ritual forms of behavior are present in most higher animals (rituals of courtship, aggression, territorial and dominant behavior)" [13].

Rituals are preserved in great variety in the culture of the 21st century. Everyone can choose examples to their taste. Rituals accompany people throughout their lives, marking bright and significant events such as meeting with flow-ers at the maternity hospital; celebrating a birthday by blowing out candles and making a wish, which must not be told to anyone in order for it to come true; a graduation party; a wedding; a funeral, which is organized by a ritual service bureau... These algorithms of actions have a great weight in the culture and continue to be taken by most people with utter seriousness.

Rituals exist in all spheres of human activity – in production, art, science, trade, services, agriculture, politics and others. They perform an important function to standardize the processes of interaction between people. In this case, rituals, on the one hand, clearly fix the established hierarchy and the corresponding distribution of roles, on the other hand, act as a means of legitimizing changes, the acquisition of new statuses and in general any transition to a qualitatively new state or a new stage of life, relative to both each individual and society as a whole.

Achieving the desired result with the help of ritual implies the need to perform a certain set of symbolic actions. The full power of such an action in the process of its performance is mediated by the symbols used and enhanced by the entourage – the plasticity of the action, odors, light and sound design. Intuitively, it is expected that the more powerful the symbols used, the greater the effect that can be achieved. That is why human sacrifice rituals were performed only on the most important occasions, requiring maximum energy, for example, before an important battle, the outcome of which depends on the survival of the people, or during the burial of the ruler, for whose well-being

in the next world the subjects are ready to do everything in their power.

In the 20th and 21st centuries, rituals of human sacrifice can be seen in many institutionalized practices such as penal and migration systems, armed conflicts as well as in the structures that constitute the financial and banking sphere, medicine and others. For some members of society to remain at the social summits, they continue to sacrifice other members of society both locally and globally, where the well-being of some countries is achieved at the expense of oppressing and exploiting others. Various forms of ritualization of killing in society serve to justify sacrifices when other legal forms of killing (duel, war, execution or terrorist act) are inapplicable or insufficient. For example, in a situation where war cannot be justified in the public mind only in terms of economic expediency, it is justified as a sacrifice to be made in the name of democracy and freedom. In reality, however, it remains clear that in capitalist reality this is only a cover for achieving pragmatic interests.

Artificial Armageddon - Prospect of the Most Massive Human Sacrifice

In a capitalist society of mass production and consumption, sacrifice can be seen as a form of consumption. In this perspective, it is "a consequence of the a priori existing differentiation in the consumption of different social strata. J. Baudrillard distinguishes two main functions of the social: the function of producing a certain surplus (demographic, economic or linguistic) and the function of eliminating it. The latter is connected with defense mechanisms - if the surplus were redistributed, it would, in his opinion, inevitably destroy social order and use value. Thus, sacrifice stands as the oldest way of eliminating surplus. M. McLuhan speaks in this regard of the culture of potlatch, an ancient practice of redistribution of wealth, in which huge product's surpluses have to be destroyed or class differences would arise that would ruin the traditional social order (smashing buildings, leaving tons of rice exposed to rain, etc.]" [14].

To quote J. Baudrillard in full: "This reversion of wealth, of all wealth, which formerly was effected by sacrifice which left no room for any accumulation of remainders, is intolerable to our societies. It is by this very fact that they are "societies" - in the sense that they always produce a surplus, remainders - whether it be demographic, economic or linguistic - and that these remainders must be cleared up

(never sacrificed, that is too dangerous: but purely and simply got rid of).

The social exists on the double basis of the production of remainders and their eradication.

If all wealth were sacrificed, people would lose a sense of the real. If all wealth became disposable, people would lose a sense of the useful and the useless. The social exists to take care of the useless consumption of remainders so that individuals can be assigned to the useful management of their lives" [15]. Thus, J. Baudrillard emphasized that in the capitalist world, sacrifice, while remaining as a practice, loses its sacred meaning, turning into a simple liquidation for the sake of preserving the established order - a potlatch.

"Potlatch is very widespread, especially where there is ease of food-gathering or food-production. For example, among the Northwest coast fishermen, or rice-planters of Borneo, huge surpluses are produced that have to be destroyed or class differences would arise that would destroy the traditional social order. In Borneo the traveler may see tons of rice exposed to rains in rituals, and great art constructions, involving tremendous efforts, smashed" [16].

Along with the conceptualization of sacrifice as potlatch, it is worth recalling again G. Bataille's concept, according to which sacrifice is different from potlatch, although similar to it as two forms of ritual "expenditure of wealth". We can even say that Bataille's concept of sacrifice breaks with the age-old tradition: sacrifice is made in the absence of any deity, it is entirely immanent, not addressed to any other subject, its essence is the liberation of things and, indirectly, of the person who refuses to use them: the sacrificial ritual seeks to destroy the thing - and only the thing - in the sacrifice [17]. In relation to a consumer society, sacrifice would be an anti-consumption, performed by the priests to maintain balance in the same way that positively and negatively charged particles, matter and antimatter balance each other. For this reason, the number of sacrifices increases in direct proportion to the amount of consumption, and the more monstrous the scale of one, the more horrifying the other.

"Sacrifice is the antithesis of production for the sake of the future, it is the extermination of wealth, which is of interest only for the moment. In this sense, to sacrifice means to give and to leave, but only the gift cannot become for the recipient an object of preservation; in giving something as a sacrificial offering, we hand it over to the world of transient annihilation. This is what it means "to sacrifice to the divinity", whose sacred essence is like fire. Sacrificing is like throwing coal into a furnace" [17].

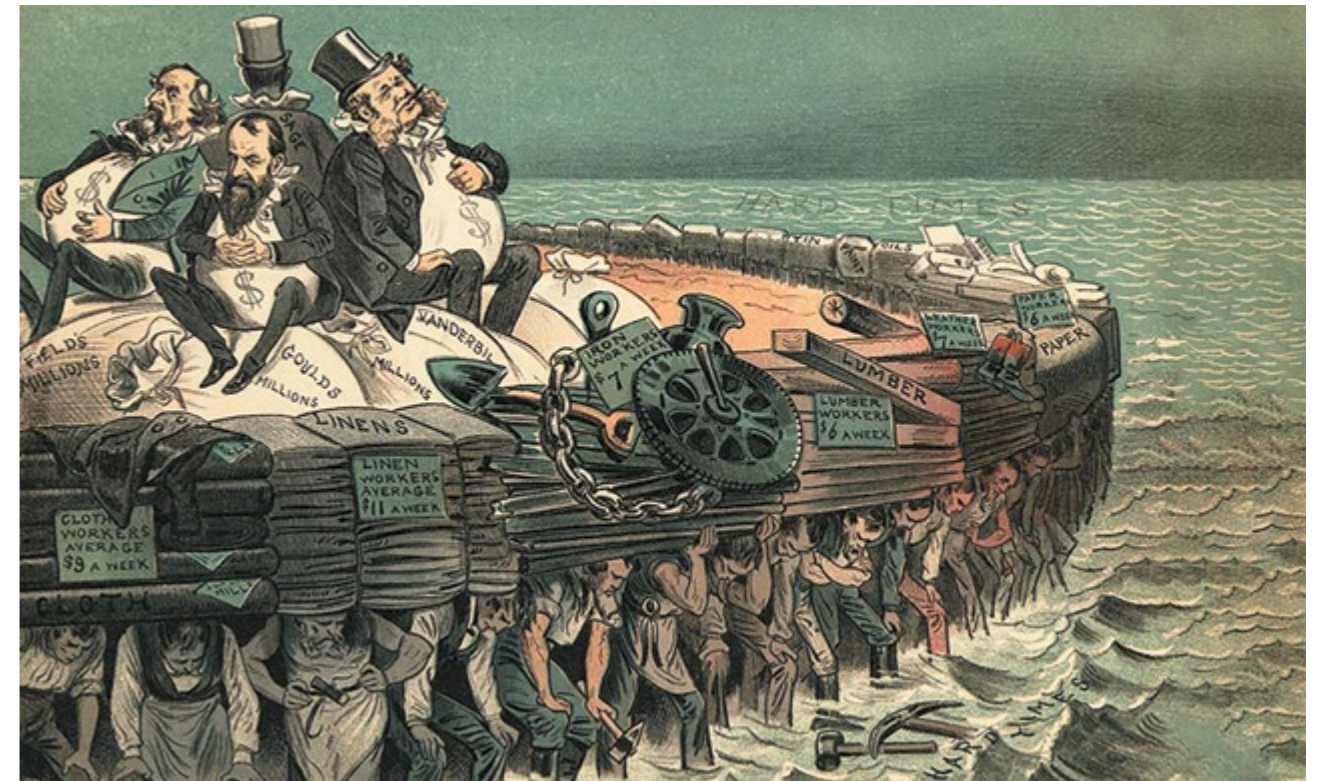

If we follow G. Bataille's idea that sacrifice is the removal of the object from the world of consumption and thus a means of returning human to the state of immanence with nature, it can be interpreted today in the following way. The "elites" find themselves in rigid antagonism with the natural world. This antagonism is currently expressed as a global ecological crisis. To remedy the situation, the ruling "global elites" must remove some people and objects from the world (through depopulation and deindustrialization) and sacrifice them in order to return to harmony with nature. Prince Philip, the husband of Queen Elizabeth II, one of the representatives of the ruling "global elite" and ideologists of the reduction of the world population, frankly did about it. Talking about his rebirth, back in 1988 he said: "In the event that I am reincarnated, I would like to return as a deadly virus, to contribute something to solving overpopulation" [18]. Since the meaning of the real elite should be the opposite as the value approach is based on the original meaning of the word "elite" (i.e., "the best"), the concept of "global elite" in this study is taken in quotation marks and further it will mean the same as false, pseudo- or quasi-elite (they are all self-appointed because they did not pass final exams, they were not chosen or appointed by anyone).

The interpretations of sacrifice through the metaphor of spending (potlatch) and as the removal of an object complement each other. The first is getting rid of surplus for the sake of preserving the equilibrium of the social system. "Elites" do get rid of the surplus human biomass. On the other hand, by excluding some people from the processes of consumption (capitalist production), they perform a symbolic action that should return them to a state of immanence with nature.

All forms of mass extermination in the 20th and 21st centuries acquire a new semantic dimension in the light of the ideas of J. Baudrillard and G. Bataille. There are many more parallels than differences between the Great Terror of the 1930s in the USSR, World War II, the genocide of the Jews, the coronavirus pandemic and Aztec human sacrifice. The declared purpose in all cases is to protect the interests of society from its enemies, racially inferior elements, deadly disease and the disfavor of the gods. All this is a certain external threat hanging over people and demanding urgent action from the state (in fact, from the power "elites" that govern the state), which stands up in their defense. The struggle is waged through the search for foci (the perpetrators or those on whom blame can be laid)

and their physical elimination – murder or isolation, which in turn also leads to death. Together with actions aimed at eliminating the danger, in all these cases the victims are eliminated as demographic surplus and at the same time excluded from the world of production and consumption, the world of things. The religious component and appeal to a higher power are outwardly abolished but remain essentially intact.

In the chosen perspective, the consideration of the goal-setting of sacrifice is transformed together with the goal-setting of society as a whole. Such attitudes are set by religion throughout most of history. First it is the worship of totem animals or plants, then of the elements, then of the deities embodied in these elements, and even later – of some universal principles embedded in the foundation of the world and revealed through the personified message of a prophet or an incarnate god. Such are the world religions – Buddhism, Christianity and Islam. In the Modern Era, personification and, consequently, the idea that the principle-based origin takes part in the destiny of human are gradually rejected. The principles themselves acquire a purely objective and indifferent coloring of scientific laws or political ideology. In the corresponding logic, at the corresponding historical stages from primordality to our days, sacrifice is conceptualized and carried out: once to sacred animals, then to the elements, to anthropomorphic gods – lords of the elements, to the embodied Absolute, to an impersonal law formulated in some field or system of knowledge (ideology, sociology, political science, criminology, epidemiology, etc.). At the same time, things are called by their proper names, no one even tries to conceal that sacrifice is sacrifice.

One can object and say that war has nothing to do with sacrifice because it is different. However, first of all, the rhetoric itself refutes the distinction. They say, after all, "to sacrifice oneself for the Motherland," "to lay one's life on the altar of the Fatherland." Secondly, the war of modern times is not an event in which everyone can participate or not participate at will. There are, of course, professional military for whom it is a choice. They are the ones who command on the battlefield, like priests in temples. They also win battles, military campaigns are won by their bosses, and wars are won by the bosses' bosses (presidents and kings). Further and higher are the interests and victories, which they prefer not to advertise as well as the identities of the final beneficiaries of armed international strife. The price is the lives of ordinary soldiers (and civilians, who sometimes die more than soldiers), who in most cases are not asked anything

and who are prepared from birth to be lambs for slaughter and scapegoats. The phrase "duty to the Motherland" is coined to explain this. In essence, they resemble Hondas children, sold by their parents and living happily ever after until the harvest fails and they are used as intended. The state disposes of the lives of its subjects at its own discretion and can sacrifice them at will, whether for pragmatic interests or for the sake of higher justice and higher powers. Thirdly, World War II, like other conflicts of the 20th century, in addition to hostilities, was associated with phenomena that in all basic parameters, form and spirit fit the concept of sacrifice. This refers to various forms of genocide, including the Holocaust. If we consider all this from the chosen perspective, it turns out that the sacrifice that formed the basis of the civilization emerged in the 21st century was the largest in the history of humankind. The number of people killed in the name of the new order is estimated in the tens, if not hundreds, of millions.

Here is what A. Hitler said in a speech on September 1, 1939, which marked the beginning of World War II: "For six years now I have been working on the building up of the German defenses. Over 90 bln have in that time been spent on the building up of these defense forces. They are now the best equipped and are above all comparison with what they were in 1914. My trust in them is unshakable. When I called up these forces and when I now ask sacrifices of the German people and if necessary every sacrifice, then I have a right to do so, for I also am today absolutely ready, just as we were formerly, to make every possible sacrifice" [19].

Here is what J. Stalin said on May 9, 1945, after Hitler's army was defeated: "The great sacrifices we made in the name of freedom and independence of our Motherland, the incalculable privations and sufferings experienced by our people in the course of the war, the intense work in the rear and at the front, placed on the altar of the Motherland, have not been in vain, and have been crowned by complete victory over the enemy" [20]. And here is what he said a little later on May 24 in a narrower circle in the Kremlin at a reception in honor of the commanders of the troops: "A different people could have said to the Government: 'You have failed to justify our expectations. Go away. We shall install another government which will conclude peace with Germany and assure us a quiet life.' The Russian people, however, did not take this path because it trusted the correctness of the policy of its Government, and it made sacrifices to ensure the rout of Germany [21].

The version of human-made COVID-19 pandemic is controversial. No one can deny the facts. The majority of people

who died during that period were old, poor and sick. This selectivity of the virus is recognized by absolutely everyone. At the same time, everything is explained by supposedly natural causes. For example, K. Schwab says: "In the US, COVID-19 has taken a disproportionate toll on African Americans, low-income people and vulnerable populations, such as the homeless. In the state of Michigan where less than 15 % of the population is black, black residents represented around 40 % of deaths from COVID-19 complications. The fact that COVID-19 affected black communities so disproportionately is a mere reflection of existing inequalities. In America as in many other countries, African Americans are poorer, more likely to be unemployed or underemployed and victims of substandard housing and living conditions. As a result, they suffer more from pre-existing health conditions like obesity, heart disease or diabetes that make COVID-19 particularly deadly" [22].

K. Schwab recognizes that the beneficiaries of the pandemic have been governments and corporations that have dumped the burden of pensions and benefits, while at the same time destroying small businesses and curtailing people's freedoms. In particular, the trampling of privacy rights is cited. "Most people, fearful of the dangers posed by COVID-19, will ask: Isn't it foolish not to leverage the power of technology to come to our rescue when we are victims of an outbreak and facing a life-or-death kind of situation? They will then be willing to give up a lot of privacy and will agree that in such circumstances public power can rightfully override individual rights. Then, when the crisis is over, some may realize that their country has suddenly been transformed into a place where they no longer wish to live. This thought process is nothing new. Over the last few years, both governments and firms have been using increasingly sophisticated technologies to monitor and sometimes manipulate citizens and employees; if we are not vigilant, warn the privacy advocates, the pandemic will mark an important watershed in the history of surveillance. The argument put forward by those who above all fear the grip of technology on personal freedom is plain and simple: in the name of public health, some elements of personal privacy will be abandoned for the benefit of containing an epidemic, just as the terrorist attacks of 9/11 triggered greater and permanent security in the name of protecting public safety. Then, without realizing it, we will fall victims of new surveillance powers that will never recede and that could be repurposed as a political means for more sinister ends" [22]. In sum, COVID-19, like any sacrifice, perpetuated

and reinforced a social order in which the few wield wealth and power over all others.

Despite technological progress, declared democracy, humanism and others, modern society retains primitive pre-rational and irrational attitudes at its core. The necessity of sacrifice is one of the key axioms. The concept of "sacrifice" continues to be sacralized. The default assumption is that in order to achieve anything in personal or social life, in relation to the state or the planet as a whole, something must be sacrificed.

If you ask "Why does society no longer practice human sacrifice?" the answer is that it is irrational. But is society really guided by rational principles? Far from it, as many researchers agree. "For a long time, the unique quality of humans was considered to be reason. It is no coincidence that this ability was noted in the self-name of our species. However, the hubris of *Homo sapiens* turned out to be unjustified. Studies of the last century have shown that great apes are capable of sign and instrumental activity. The IQ difference is paradoxically explained by the fact that animals are too rational. They do not do anything for nothing, including not multiplying entities. Instinct is enough for survival, so there is no need to use reason.

Man differs from the beast not by reason, but by faith. Therefore, the phenomenon of culture can be explained only through religion" [6].

If this is true, then irrationality is the defining feature of culture. There are many indirect confirmations, starting from the fact that people throughout their history have been fighting, killing and destroying what they have created with great difficulty, and ending with the position and the negligible role that the carriers of scientific and engineering rationality play in society at different times, up to the end of the first quarter of the 21st century.

The humanity of modern society can be disputed as well as its rationality, just like other possible qualities that would make sacrifice (including the human one) impossible in the modern world. If there are no such indisputable qualities, then sacrifice is possible as a mass and system-forming practice.

Human sacrifice is a very successful matrix for structuring and comprehending the processes that began at the end of the last quarter of the 20th century and in the first quarter of the 21st century, which have become quite radical. We are talking about a profound restructuring of the world order – the reform of capitalism with all its consequences, including the need to reduce the world's population.

The logic of sacrifice is the only one possible for such a transition, because it allows us to achieve the desired result and at the same time justify the extermination of humanity on a global scale. Moreover, extermination can be carried out as painlessly as possible, since the need for the victim to accept his or her fate is probably the most important distinguishing feature of sacrifice as a form of killing. It is enough to set people up for self-sacrifice, and they themselves will go to the slaughter, leaving no offspring. How does such a process take place, how is it structured, and to what result will it lead?

The Club of Rome report entitled "The Limits to Growth" [23], published in 1972, can be taken as a starting point, although the roots of the process of interest can be found even deeper in time, for example, in an essay of T. Malthus [24]. Be that as it may, the "global elites" faced the problem of planet's overpopulation and exceeding the limits of world population growth. The terrible specter of ecological catastrophe appeared on the horizon. In order to avoid it and propitiate nature, a human sacrifice was required, which was then planned and probably already started to be executed according to the quickest and simplest plot of three acts.

Act 1. Pandemic ("plague"). Creating tension in society while limiting the freedoms of the population through total digital control makes it possible to organize the environment for waging a local nonnuclear war in Europe. Thanks to the practices of lockdowns and the suppression of protests arising in this context, the population turns out to be passive enough meekly to accept the new restrictions and inconveniences associated with such a war. There are no mass protests either in the belligerent countries or in the states providing financial and military support to one of the parties. People during the pandemic got used to the idea that the state decides their fate for them.

Act 2. Local nonnuclear war. European economy weakens due to a significant increase in the cost of energy resources. New political and economic camps and coalitions are formed. More participants are gradually involving in the conflict. Tensions rise to an extreme point.

Act 3. Global nuclear war – achieving the required result.

Before that, decades of preparation for the ritual had been going on. Hollywood worked tirelessly, introducing into mass consciousness the idea of bleak and catastrophic future, sowing hatred in society, popularizing violence, egoism, hedonism, etc. The mass media and education worked for the same purpose, destroying the principles

of humanity and progress, instead of them implanting in our heads the need to strive for success no matter what and sowing moral relativism, in which there is neither good nor evil, but only profit or its absence.

The family as a fundamental institution has been devalued. In fact, people have been forced to perceive themselves as a kind of meaningless biomass (like mold), uncontrollably multiplying and destroying nature. Such humanity is ready to sacrifice itself in the interests of nature, glorified by eco-activists and representatives of green parties. And although each person will protest against the fatal unfolding of events for civilization by the instinct of self-preservation, having no doubts about the other. In a YouGov survey of nearly 8,000 people from eight countries (Brazil, Egypt, France, Hungary, India, Japan, Nigeria and the United States), the most common statement was that the current world population is too large. In all countries except Japan, more than 50 % of respondents felt this way. In Japan, it was 43 %. In addition, the majority is convinced that two children per family is also too many [25]. This opinion is not accidental but purposefully formed. As an illustration, here is a clipping from The Times newspaper with the article "Kids are cute but they're not really eco-friendly" [26]. The text talks about how much resources are consumed and how each new child consumes and pollutes the environment. All this leads to what is so necessary in sacrifice – the victim accepts his or her fate without complaint.

Technically, everything is also ready for the largest human sacrifice in history. Nuclear weapons were invented by engineers commissioned by the ruling "global elites" more than 70 years ago, then widely distributed and replicated by them. The fingers of the newly-appointed priests are already over the red start buttons. If the society in the 21st century as well as thousands of years ago continues to act according to the rules of ritual, the chance of human-made Armageddon is very high. The representatives of the "elites" themselves are talking about it, either calling to come to their senses or preparing the victims for a gruesome end.

"The prospects for peace keep diminishing. The chances of further escalation and bloodshed keep growing," the UN Secretary General said on February 6, 2023. He reminded that the so-called Doomsday clock, which is a symbolic dial created 76 years ago by nuclear scientists, including A. Einstein, today shows one and a half minutes to midnight, i.e., before the self-destruction of humanity. Never, not even during the Cold War, has the hand of this metaphorical clock been so close to the point of no return [1].

Kids are cute but they're not really eco-friendly

One less baby helps the planet more than giving up meat, car

Having children is the most destructive thing a person can do to the environment, according to a new study.

Researchers from Lund University in Sweden found having one fewer child per family can save "an average of 58.6 tonnes of CO₂-equivalent emissions per year".

Eating meat, driving a car and travelling by aeroplane made up the list of the most polluting things people can do to the planet.

But having children was top, according to the new study, published in the journal Environmental Research Letters.

"A US family who chooses to have one fewer child would provide the same level of emissions reductions as 684 teenagers who choose to adopt comprehensive recycling for the rest of their lives," it said.

Lead author Seth Wynes told The Local: "We found there are four actions that could result in substantial decreases in an individual's carbon footprint: eating a plant-based diet, avoiding air travel, living car free and having smaller families."

"For example, living car-free saves about 2.4 tonnes of CO₂ equivalent per year, while eating a plant-based diet saves 0.8 tonnes of CO₂ equivalent a year."

The paper, which studied analysed 39-peer reviewed journals studying the environmental policies of several major economies, found most governments focused on incremental changes which have "much smaller potential to reduce emissions".

Although governments focused on increasing recycling schemes and using energy efficient light bulbs, these methods were between four and eight times less effective than eating a plant-based diet.

Researchers found that avoiding one trans-Atlantic flight per year can save between 0.7 and 2.8 tonnes of CO₂ equivalent per year (depending on the distance travelled, amount of luggage on board and how many passengers on the flight) whereas recycling will typically only save 0.21 tonnes of CO₂ equivalent per year. This means recycling is 3–13 times less likely to save the planet than avoiding that extra flight. Carbon emissions must fall to two tonnes of CO₂ per person by 2050 to avoid severe global warming say researcher.

Caroline Mortimer



GOOD FOR THE EARTH

Activity	CO ₂ saved/year (tonnes)
Not having babies	58.6
Avoiding trans-Atlantic flights	2.8
Living car-free	2.4
Washing clothes in cold water	0.3
Upgrading light bulbs	0.1
Eating a plant-based diet	0.8

Alternatives to Sacrifice: Ritual and Engineering

When it comes to evaluating a war, one way or another the question arises: should the attacked party have fought back aggressively with weapons in their hands? Often the situation is analyzed using analogies of a domestic nature. For example, they compare it to an armed intrusion into a house and causing harm or threats to family members. Then it is said that it is absolutely natural to protect one's home and loved ones. There is not and cannot be any alternative. But is this the case? Is it rational to resist an enemy who is known to be stronger than you and who does not intend to destroy you, but only wants, for example, to rob you? In a different formulation, this is the question "Trick or treat?" If we describe the situation in this way, it turns out that most people would prefer to hand over their wallet. In this case, the chance of being killed remains, but the chance of survival increases significantly. We can conclude that such a choice is rational if survival is the ultimate goal. If the highest goal is something else – preservation of "honor" or "wallet" – then handing over the wallet is not rational. Therefore, the rationality of the choice depends on the goals that guide the decision.

Human sacrifice can be considered rational if the purpose of society is to preserve and maintain the existing hierarchy or to establish a new hierarchical system as part of a social revolution, upheaval, etc. Indeed, from the point of view of ruling groups or groups claiming power, such goals may be paramount. However, from the point of view of social development, this cannot be so. The goal should be to preserve the life of the population, to improve the quality of life and to establish justice in the distribution of produced and consumed goods. For example, the US Constitution states as a purpose "to form a more perfect Union, establish Justice, insure domestic Tranquility, provide for the common defence, promote the general Welfare, and secure the Blessings of Liberty to ourselves and our Posterity" [27]. The goal outlined in the Constitution of the Russian Federation is also very specific and does not directly involve the protection of the interests of any elite group. It is "to ensure the well-being and prosperity of Russia" [28]. These goals look reasonable and, at first glance, not tied to the interests of any single group of people. Yet it is not so. It is just that the group of people is a little bigger – not the ruling class but a separate country, opposing its interests to the interests of all other countries. In the end, the goal still turns out to be to protect the interests of the class ruling the state.

It is just that the real goal is hidden behind outwardly humane and right formulations.

Rationality alone cannot be a panacea against irrational attitudes. Reason and rationality are only tools. As D. Hume said, "It is not contrary to reason to prefer the destruction of the whole world to the scratching of my finger. It is not contrary to reason for me to chuse my total ruin, to prevent the least uneasiness of an Indian or person wholly unknown to me. It is as little contrary to reason to prefer even my own acknowledged lesser good to my greater, and have a more ardent affection for the former than the latter" [29]. The same author rightly asserted: "We speak not strictly and philosophically when we talk of the combat of passion and of reason. Reason is, and ought only to be the slave of the passions, and can never pretend to any other office than to serve and obey them" [29].

Agreeing with the English thinker, we would have to conclude that society in general has never been and cannot be rational in its foundations. One way or another, in the beginning there will be a passion for power, which leads to aggression and destruction – what F. Nietzsche called the Dionysian beginning of culture – "primordial chaos and terror, bacchanalian awe, the thrill of intoxication and ecstasy" [30]. Even if this is true and passion is the real basis of everything done by human and people, the activity itself can still be rational in nature. In this perspective, sacrifice can also be understood as a rational action in the spirit of B. Pascal's philosophical wager*: if sacrifice does not work, then abandoning it adds or subtracts nothing to the status quo; if sacrifice does work, then abandoning it is a loss of gain.

* Pascal's Wager is a practical argument for belief in God formulated by B. Pascal, a French religious philosopher, mathematician and physicist. In "The Thoughts of Blaise Pascal" (1657–1658), he proposed the following argument to demonstrate the rationality of Christian faith:

- if God does not exist, then the atheist has little to lose by believing in him and correspondingly little to gain by not believing in him;
- if God exists, then the atheist gains eternal life by believing in him and loses infinite good by not believing.

"Let us weigh the gain and the loss in choosing heads that God is. Let us weigh the two cases: if you gain, you gain all; if you lose, you lose nothing. Wager then unhesitatingly that he is.

Now what evil will happen to you in taking this side? You will be trustworthy, honourable, humble, grateful, generous, friendly, sincere, and true. In truth you will no longer have those poisoned pleasures, glory and luxury, but you will have other pleasures. I tell you that you will gain in this life, at each step you make in this path you will see so much certainty of gain, so much nothingness in what you stake, that you will know at last that you have wagered on a certainty, an infinity, for which you have risked nothing" [31].



Why then abandon the practice and the corresponding attitude, rooted not only in the consciousness of people but also in the unconscious layer of the psyche and in the operational space, which has proved itself perfectly throughout the history of humankind? And are there any alternatives?

We can say that most local civilizations are civilizations of sacrifice, or sacrificial civilizations (from the Latin *sacrificium* – sacrifice). Sacrificiality is a fundamental attribute of any of them. However, within civilization (first of all, the New European one) something is gradually emerging that acts as an alternative to ritual, understood as the main way of effective transformation of reality. Engineering acts as such a substitute. Like sacrifice and any other ritual, engineering is rational in form. It has its own goal-setting structures and appropriate tools for achieving goals. It draws on a scientific picture of the world in the same way that ritual draws on religious concepts. It is quite difficult to see the differences, looking formally. However, they are fundamental.

Ritual involves performing a certain set of actions to achieve a certain result. Engineering does the same thing. The difference is in the specificity of the sequences. In ritual, the sequence is kind of broken. Between the action

and the desired result, supernatural forces come into play, and the way they work remains incomprehensible to humans. Naturally, this approach is impossible for engineering. Any technology, all mechanisms and devices, any engineering algorithm must fulfill a clear and distinct function. This is the only guarantee of engineering efficiency.

Using an analogy, we can say that engineering is like a standard syllogism like "if A, then B; if B, then C. Therefore, B is C". For example, "if it is raining, you must take an umbrella; if you take an umbrella, you won't get wet; I have taken an umbrella, therefore, I won't get wet". A ritual is an abbreviated syllogism, or enthymeme. In an enthymeme, one of the arguments is missing. In the example above, it could be the argument that an umbrella protects against rain. By removing it, we get a statement like "if A, then C" – "if it rains, you won't get wet". This is how the sequence in the ritual is presented. If you kill a ram, the hunt will be successful. The missing argument is that the god of the hunt is pleased with the sacrifices offered by people in his honor. But it is clear that such arguments are beyond the boundaries of human experience, unlike the practically verifiable ability of the same umbrella to protect against precipitation. Hence, besides the formal difference

between ritual and engineering, there is a substantive difference, consisting in the practical ability to verify the effectiveness of all actions in their sequence.

Therefore, engineering at a sufficiently high level of scientific development turns out to be a more reliable, tangible and predictable tool for active transformation of reality than a ritual relying on supernatural and otherworldly forces. Guaranteed efficiency of all algorithms in the chain of actions gives the highest probability of achieving the goal. At the same time, the impossibility to check the effectiveness of the most important algorithms of the ritual does not allow to be sure of its effectiveness. As a result, the shaman's tambourine and incense smoking cause rain with a conditional probability of 50/50 – "will be raining / will not be raining", which has nothing to do with scientific and engineering probability, like any other guessing on the coffee grounds. Nevertheless, people continue to believe in rituals and use them.

Another difference between ritual and engineering is that the purpose of the ritual and the purpose of the subject (the priest) who performs it coincide. The priest must get a result. At least his authority and well-being depend on it. Thus, ritual personalizes the goal. Engineering, on the other hand, has a practical and impersonal goal, as it is achieved not through the expressiveness of the shaman's dance and the depth of the trance into which he entered but through devices and mechanisms which, although created by human, are already isolated from their creator at the moment of the work. Engineering works according to the laws of physics of the real but not virtual world, for which the law is not written: this world, invented by people and not created by God and cognizable by human, will work under laws the shaman wants. This is another side of the democratic nature of engineering compared to the elitism of ritual. Nevertheless, in modern society, which claims to be democratic, ritual retains its appeal and is valued even more than engineering solutions, which have become part of everyday life and perform auxiliary functions.

The ritual's appeal against engineering has many explanations. Ritual is an apparently simpler way deeply rooted in tradition and thus sanctified and validated by it. Ritual may promise the attainment of ultimate goals, such as immortality, world domination, infinite wealth, etc. Finally, ritual is more suitable than engineering to fulfill the function of consolidating and preserving the domination of certain social classes over others.

Unlike ritual, engineering has as its consequence and function not the preservation and strengthening of the domination of some social classes over others but,

on the contrary, the reduction of inequality in society. This is for two main reasons – public comprehensibility and public accessibility. Firstly, as has been shown, engineering requires clarity and verifiability of all actions in the accepted and utilized, clear and unambiguous sequences of those actions to achieve the goals. This signifies the transparency and public accessibility of engineering as opposed to the closed, esoteric nature of ritual. Secondly, being a clear and publicly accessible way of transforming reality, engineering and its fruits can be used by everyone without status restrictions.

Ritual was invented by the priests who ruled primitive society. They and their descendants, up to the modern "elites", have maintained it for thousands of years of human history. They do not know and do not want another, more effective tool for working with reality. For these and other reasons, ritual has been and will be for some time to come the dominant way of effectively transforming reality. And if this reality faces crises, the most powerful rituals aimed at overcoming crises will be used. Among such rituals is human sacrifice.

Civilization of the Future: Sacrificial or Engineering?

Much of what has recently become known about European and American "elites" indirectly confirms the prevalence of certain occult beliefs and practices in their circles. Starting with the accusations of pedophilia against M. Jackson and ending with the global network of human trafficking created by J. Epstein, including the supply of child sex slaves for billionaires, presidents and members of royal families. It is likely that the people who run the world adhere to some moral principles unique to their circle. There are probably Satanists who sacrifice babies. None of this is provable. But there is no need to prove it.

The preceding consideration shows that ritual and human sacrifice as one of its most powerful forms have been and remain an instrument for establishing and preserving the domination of some people over others, enshrined in the social order. Even the most democratic countries publicly resort to ritual in the form of elections, referendums, courts, rallies, etc. If some forms of rituals are used, there is no reason to believe that others will not be used as well. And if at the end of the first quarter of the 21st century humanity began to experience another global metamorphosis, then, as before, we should expect that this transformation

will be accompanied by global sacrifices. These have probably already begun in the form of pandemics and a major war in Europe. Probably, as the most ardent haters of everything that comes from T. Malthus, the Club of Rome and the Davos Forum expected, these processes will result in the death (sacrifice) of a large part of humanity.

In fact, the modern (capitalist) world order has no other way of self-preservation than to commit the most massive human sacrifice in history. The presence of more than 8 bln people on the planet jeopardizes the dominance of the "elites", as they are unable, while maintaining their power and wealth, to provide a high level of existence for such a huge human mass. If they do not, this critical mass may sweep them away. Furthermore, capitalism in the age of automation does not need so many laboring hands, and especially not so many mouths. Finally, maintaining the capitalist mode of production and distribution at this density of inhabitants may very soon make our planet unusable for anyone at all – neither for "elites" nor for other human masses. The sacrifice of, let us say, 7 bln people would solve everything. Such plans and such a possibility, as can be seen from all the preceding consideration, are legitimate from the point of view of historical experience and traditional practices, beginning with potlatch and ending with World Wars I and II. Is a different outcome possible?

Since the Earth's human civilization has only one way of activity transformation of reality, which can be somehow compared to ritual, there can be only one alternative to ritual – engineering and establishment of engineering civilization.

An engineering civilization will not make sacrifices to achieve a goal because the very purpose of engineering is practical and impersonal. Only such a goal can become universal and unite people in a new way, opening new opportunities for them.

The highest individual goal is individual happiness. The highest common goal is common happiness. Such a goal can only be impersonal, and therefore, it is achievable only on the path of engineering without any priests, in this case, power "elites", claiming special laurels and percentages of profit.

The political programs of the engineering civilization will become absolutely transparent, since no argument in them will be overlooked and each argument can be tested practically in terms of its effectiveness. There will be no more talk about abstract freedom, dominance, justice and the like. Instead, there will be talk of new agricultural technologies, new energy, new transport, new urbanism

and, finally, a fundamentally new non-rocket way of near space industrialization.

The economy of an engineered civilization will not resemble magic, with its jumble of complex interest rates, futures and the intricacies of the credit and banking system and stock markets. The economy will be based on engineering production – completely transparent and predictable.

The culture of engineering civilization, created by thousands of previous generations of nameless engineers (even if they had not graduated from universities established by the "elites"), starting from the inventor of the fire, will be oriented again to simple and understandable civilizational values: happy family, interesting job, creative work, Live Nature in its highest manifestation – the biosphere of the planet, which nurtured and raised our Earth's human civilization. These values in sacrificial civilization have been replaced by abstractions like wealth and success, because the very essence of civilizational sacrifice is not production but exchange. Sacrifice is an exchange, and it requires values that can be exchanged.

Everything is prepared for the formation of engineering civilization in the first quarter of the 21st century. Engineering is no longer inferior to ritual in any of the things in which it has been inferior for most of the time of humankind's existence as a planetary engineering society. Engineering helps to fight drought and increase crop yields many times over, allows us to travel at the speed of sound and transmit information at the speed of light, can cure diseases and prolong life, allows us to hear the voices of the long dead and peer into the past of distant galaxies. The only thing that engineering does not do as well as ritual is not serving the enslavement and power of some over others: an airplane created by an engineer is not a slave to the pilot, and the pilot is not a slave to the airplane. But the pilot can become someone else's slave, including by means of an airplane that is someone else's property. However, engineering does not need that. It does not aim to take away and limit. It claims to be much more than that. It is ready to give everyone as much as they need.

Engineering civilization will reassemble our human world in a new way. It will create biospheric forms of settlement, safe and environmentally friendly transport systems, bioenergy, eco-industry, organic agriculture, capable of feeding, clothing and footwear for 10 bln people, while ensuring global safety rather than regional and country-specific ones – infrastructure, transport, energy, food, demographic, environmental, sociopolitical and a dozen other civilizational safeties.

Conclusion

The listed and other global problems, including limited Earth's resources, global warming and rising ocean levels, are not really determinants for the future of humankind. A much greater civilizational danger is not engineering achievements but the most terrible social "technology" generated by "elites": human sacrifice, based on pagan rituals, supernatural and otherworldly forces. All this was generated by civilization for the simple reason that our human civilization is exactly engineering ("technogenic", "technocratic", "industrial"), but unfortunately it is governed not by the engineers who created it but by pseudo-elites, newly appeared priests, for the sake of their own profit and preservation of their power. Only engineers are capable of solving the global problems of our time, not "elites" – this cancerous tumor in the civilizational organism. Even one cancer cell among trillions of healthy ones in the human body feels itself as an elite and for its own benefit starts to control healthy cells and organs until by metastasizing kills the whole organism and dies. Now our engineering civilization is penetrated by metastases from "global elites" controlling it, but it is still alive and can and should be cured. Methods of cancer treatment are known, they have been also created by engineers.

Dolphins do not have engineering and the resulting science, engineering, technology, arts, education, health care, urban environment, societies, politics and much more, because this civilization is not engineering but purely animal, albeit highly organized. However, they have no governing elites and no problems caused by them.

Engineering will allow people to relocate all production harmful to the Earth's Live Nature into space, solving human-made environmental problems once and for all, separating two antagonists in space: the biosphere and the technosphere. People will be able to discover new planets and travel to other galaxies. On Earth, our cradle of civilization, there will be no limitations on population, no shortage of products and territories, no reasons for wars and no more sacrifices will be needed – neither human nor natural.

References

1. *V OON preduprezhdayut: yadernaya ugroza dostigla samogo vysokogo urovnya s momenta okonchaniya kholodnoy voyny [UN Warns That the Nuclear Threat Has Reached Its Highest Level Since the End of the Cold War] [Electronic resource]. – Mode of access: <https://news.un.org/ru/story/2023/03/1438242>. – Date of access: 06.09.2023.*

2. *Tokarev, S. O zhertvoprinosheniyakh [About Sacrifices] [Electronic resource] / S. Tokarev. – Mode of access: <http://Annales.info/other/small/tokarev.htm>. – Date of access: 04.07.2023.*
3. *Bataille, G. Theory of Religion [Electronic resource] / G. Bataille. – New York: Zone Books, 1989. – Mode of access: <https://anarch.cc/uploads/georges-bataille/theory-of-religion.pdf>. – Date of access: 06.07.2023.*
4. *Borisov, S. Genealogiya nasiliya: zhertvoprinosheniye kak arkhetyip terrorizma [Genealogy of Violence: Sacrifice as an Archetype of Terrorism] [Electronic resource] / S. Borisov, A. Artsiuh. – Mode of access: <https://cyberleninka.ru/article/n/genealogiya-nasiliya-zhertvoprinosheniye-kak-arkhetip-terrorizma>. – Date of access: 11.07.2023.*
5. *Freud, S. Totem and Taboo [Electronic resource] / S. Freud. – Mode of access: <https://www.gutenberg.org/files/41214/41214-h/41214-h.htm>. – Date of access: 07.07.2023.*
6. *Erlich, S. Svoyevremennost' zhertvy [Timeliness of the Sacrifice] [Electronic resource] / S. Erlich. – Mode of access: https://magazines.gorky.media/novy_mi/2011/12/svoevremennost-zhertvy.html. – Date of access: 07.07.2023.*
7. *Chelovecheskiye zhertvoprinosheniya nazvali klyuchevym etapom v poyavlenii tsivilizatsii [Human Sacrifice Called a Key Stage in the Emergence of Civilization] [Electronic resource]. – Mode of access: <https://naked-science.ru/article/sci/chelovecheskie-zhertvoprinosheniya>. – Date of access: 07.07.2023.*
8. *Ivik, O. Istoriya chelovecheskikh zhertvoprinosheniy [History of Human Sacrifices] [Electronic resource] / O. Ivik. – Mode of access: <https://4italka.ru/nauka-obrazovanie/istoriya/236068/fulltext.htm>. – Date of access: 08.07.2023.*
9. *Nietzsche, F. The Gay Science [Electronic resource] / F. Nietzsche. – New York: Cambridge University Press, 2013. – Mode of access: https://edisciplinas.usp.br/pluginfile.php/6569496/mod_resource/content/1/Nie-tzsche%20C2%B7%20The%20Gay%20Science%20%28Cambridge%20Texts%20in%20the%20History%20of%20Philosophy%29.pdf. – Date of access: 08.07.2023.*
10. *Partyka, N. Capitalism as a Form of Human Sacrifice: The Comedy of Innocence and the Comedy of Guilt [Electronic resource] / N. Partyka. – Mode of access: <https://www.hamptonthink.org/read/capitalism-as-a-form-of-human-sacrifice-the-comedy-of-innocence-and-the-comedy-of-guilt>. – Date of access: 11.07.2023.*
11. *Marx, K. Manifesto of the Communist Party [Electronic resource] / K. Marx, F. Engels. – Mode of access: <https://paracetamom.github.io/the-communist-manifesto/>. – Date of access: 08.07.2023.*

12. *Katasonov, V. Inklyuzivnyy kapitalizm kak glavnyaya ideya velikoy perezagruzki [Inclusive Capitalism as the Main Idea of the Great Reset] [Electronic resource] / V. Katasonov. – Mode of access: https://tsargrad.tv/articles/inkluzivnyy-kapitalizm-kak-glavnaya-ideya-velikoy-perezagruzki_354889. – Date of access: 06.09.2023.*
13. *Il'chenko, A. Ritual'noye povedeniye i mifologicheskoye soznaniye v sovremennom mire [Ritual Behavior and Mythological Consciousness in the Modern World] [Electronic resource] / A. Il'chenko. – Mode of access: <http://anthropology.ru/ru/text/ilchenko/ritualnoe-povedeniye-i-mifologicheskoe-soznanie-v-sovremennom-mire>. – Date of access: 11.07.2023.*
14. *Ovrutskiy, A. Potrebleniye: filosofskiy aspekt pravovogo regulirovaniya [Consumption: Philosophical Aspects of Legal Adjustment] [Electronic resource] / A. Ovrutskiy. – Mode of access: <https://cyberleninka.ru/article/n/potrebleniye-filosofskie-aspekty-pravovogo-regulirovaniya>. – Date of access: 11.07.2023.*
15. *Baudrillard, J. In the Shadow of the Silent Majorities, Or, The End of the Social. And Other Essays [Electronic resource] / J. Baudrillard. – Mode of access: https://monoskop.org/images/c/c4/Baudrillard_Jean_In_the_Shadow_of_the_Silent_Majorities_or_The_End_of_the_Social_and_Other_Essays.pdf. – Date of access: 12.07.2023.*
16. *McLuhan, M. Understanding Media: The Extensions of Man [Electronic resource] / M. McLuhan. – Mode of access: <https://designopendata.files.wordpress.com/2014/05/understanding-media-mcluhan.pdf>. – Date of access: 12.07.2023.*
17. *Bataille, G. Proklyataya chast' [The Accursed Share] [Electronic resource] / G. Bataille. – Mode of access: <https://library.khpg.org/files/docs/1328602703.pdf>. – Date of access: 06.07.2023.*
18. *Did I Say That? [Electronic resource]. – Mode of access: <https://www.theguardian.com/lifeandstyle/2009/jun/21/quotes-by-prince-philip>. – Date of access: 09.06.2023.*
19. *Speech by Herr Hitler to the Reichstag on September 1, 1939 [Electronic resource]. – Mode of access: <https://greatspeeches.wordpress.com/2008/11/25/speech-by-herr-hitler-to-the-reichstag-on-september-1-1939/>. – Date of access: 12.07.2023.*
20. *Joseph Stalin: Victory Speech Broadcast from Moscow on May 9, 1945 [Electronic resource]. – Mode of access: <https://greatspeeches.wordpress.com/2008/11/23/joseph-stalin-victory-speech-broadcast-from-moscow-on-may-9-1945/>. – Date of access: 12.07.2023.*

21. *Toast to the Russian People at a Reception in Honour of Red Army Commanders Given by the Soviet Government in the Kremlin on Thursday, May 24, 1945 [Electronic resource]. – Mode of access: <https://www.marxists.org/reference/archive/stalin/works/1945/05/24.htm>. – Date of access: 12.07.2023.*
22. *Schwab, K. COVID-19: The Great Reset [Electronic resource] / K. Schwab, T. Malleret. – Mode of access: <http://reparti.free.fr/schwab2020.pdf>. – Date of access: 20.04.2021.*
23. *The Limits to Growth / D.H. Meadows [et al.]. – New York: Universe Books, 1972. – 205 p.*
24. *Malthus, T.R. An Essay on the Principle of Population [Electronic resource] / T.R. Malthus. – Mode of access: <https://archive.org/details/essayonprinciple00malt/page/n21/mode/2up>. – Date of access: 07.06.2023.*
25. *Nater, O. UN Survey Shows Overpopulation Concerns Are Widespread [Electronic resource] / O. Nater. – Mode of access: <https://populationconnection.org/blog/unsurvey-shows-overpopulation-concerns-are-widespread/>. – Date of access: 14.07.2023.*
26. *Mortimer, C. Kids Are Cute but They're Not Really Eco-Friendly [Electronic resource] / C. Mortimer. – Mode of access: <https://www.slowrobot.com/wp-content/uploads/sites/67/2021/11/35fa6dbc-5b96-4f62-b70d-606fbbf1a21d-23814.jpg>. – Date of access: 14.07.2023.*
27. *Constitution of the United States [Electronic resource]. – Mode of access: <https://constitution.congress.gov/constitution/>. – Date of access: 14.07.2023.*
28. *Constitution of the Russian Federation [Electronic resource]. – Mode of access: <http://www.constitution.ru/en/10003000-01.htm>. – Date of access: 14.07.2023.*
29. *Hume, D. A Treatise of Human Nature [Electronic resource] / D. Hume. – Mode of access: https://www.gutenberg.org/files/4705/4705-h/4705-h.htm#link2H_4_0075. – Date of access: 15.07.2023.*
30. *Apollonicheskoye i dionisiyskoye [Apollonian and Dionysian] [Electronic resource]. – Mode of access: https://dic.academic.ru/dic.nsf/enc_philosophy/86/%D0%90%D0%9F%D0%9E%D0%9B%D0%9B%D0%9E%D0%9D%D0%98%D0%A7%D0%95%D0%A1%D0%9A%D0%9E%D0%95. – Date of access: 15.07.2023.*
31. *Pary Paskalya [Pascal's Wager] [Electronic resource]. – Mode of access: <https://azbyka.ru/pari-paskalya>. – Date of access: 16.07.2023.*

Creation of Mathematical Model of the General Planetary Vehicle on the Basis of Finite Element Method

A. Unitsky^{1,2}
Dr. of Philosophy
in Information Technologies
(Transport)

A. Pakulnitski²

¹ Astroengineering Technologies LLC,
Minsk, Belarus

² Unitsky String Technologies Inc.,
Minsk, Belarus



The authors describe approaches to the development of a software complex designed for mathematical modeling of the General Planetary Vehicle (GPV) behavior with the help of common calculation elements. Such approaches are based on the finite element method. There is a review of the process of creation of a beam finite element that can be used for the GPV behavior description. The aircraft nonlinearities arising from its complex geometry, irregular structure and loading features are considered. The article presents the libraries which were used in the course of the software complex designing, as well as the justification of their application according to the modularity of the product and individual functions of each module. The finite element verification based on the core issues of mechanics and further comparison with the alternative solutions have been performed. The element has been tested on tasks of the Unitsky String Transport (uST) due to the similarity of their nonlinearity as well as sufficient experimental data to assess the accuracy, stability and convergence of the developed finite element.

Keywords:

beam finite element, Euler-Bernoulli element, finite element method, mathematical model of the General Planetary Vehicle (GPV), Newton-Raphson method, Python programming language.

Introduction

Creation of mathematical model of the General Planetary Vehicle (GPV) [1-3] is a fundamental stage in performing real engineering calculations in this field. Taking into account the complexity of the design, long length (40,076 km), huge mass (up to 40 mln tons), high velocity of the flywheels (up to 12 km/s) and various modes of operation of the aircraft as well as the impossibility of conducting a number of full-scale tests, mathematical modeling speeds up the work, saves resources and provides variability of solutions to such application tasks. In particular, it makes it possible to describe the operating modes and processes occurring with the GPV during takeoff, direct operation in equatorial orbit and landing as well as to forecast abnormal situations that may arise during operation and plan possible ways to avoid them.

References [1, 3] contain an analytical method for obtaining the kinematic characteristics of the GPV motion, and the issues related to energy consumption during its orbital launch and operation are considered. The present study describes the process of creating a software package designed for mathematical modeling of the GPV behavior through the use of universal beam-type calculation elements.

The development is based on the finite element method as one of the most common numerical methods used for engineering problems involving systems with complex geometry or irregular structure. This is due to the fact that this way has no significant limitations in the geometry of the bodies under study and methods of load application, which means that it can be considered as a rather universal mechanism that allows solving problems from different fields, however, it requires certain computing power.

It should be noted that the finite element method, like any other numerical one, is an approximate method, so the problems of accuracy, stability and convergence are relevant for it. The method has been repeatedly tested on various types of practical problems, and at present many commercial products are based on it. However, despite the considerable amount of accumulated knowledge, the existing developments do not provide an opportunity to perform modeling of the considered structure taking into account the given loads and boundary conditions. Therefore, there is a need for a separate product that would allow to create the necessary models and calculation patterns, optimize the computing time and power costs as well as to solve the problems of scaling and continuity.

Main Approaches to Modeling of Software Complex

Modeling of mechanical processes related to the GPV operation involves a significant number of areas, among which we can highlight the problems of solid mechanics, hydraulic gas dynamics and electromagnetism.

The main stages of this work are focused on the creation of a finite element for solving the problems of solid mechanics, which contributes to the achievement of a number of objectives:

- to select stiffness-mass and stiffness-damping characteristics of the GPV structural elements;
- to determine the natural frequencies of the GPV vibrations;
- to carry out a harmonic analysis and analysis related to random vibration;
- to analyze the stress-strain state.

It should be noted that real engineering systems are considered as linear only in a limited range of problems. Despite the admissibility of linear calculations, the large size and scale of the GPV structure, which exceeds the size of Earth, introduce a number of nonlinearities into the modeling process. Other influencing factors include:

- nonuniform thrust of linear electric motors along the length of the GPV;
- nonuniform efficiency factor of linear electric motors along the length of the GPV and its change in time (acceleration and braking of belt flywheels, including that depending on their velocity in the range of 0-12 km/s);
- nonuniformity of mass along the length of the GPV (primarily due to uneven positioning of passengers and cargo);
- initial geometric deviations from the ideal circle (repetition of the geoid shape on oceanic sections and large terrain relief on land and when crossing mountains);
- nonuniformity of the planet's gravity field (Figure 1);
- nonlinearities of magnet forces in the magnetic suspension of linear rotors (flywheels);
- other.

The developed software package is based on the Euler-Bernoulli beam element [4], the display of which is shown in Figure 2.

This element describes linear behavior, however, taking into account the abovementioned nonlinearities, deformation effects of higher order of smallness and geometric stiffness are added to the mathematical model.

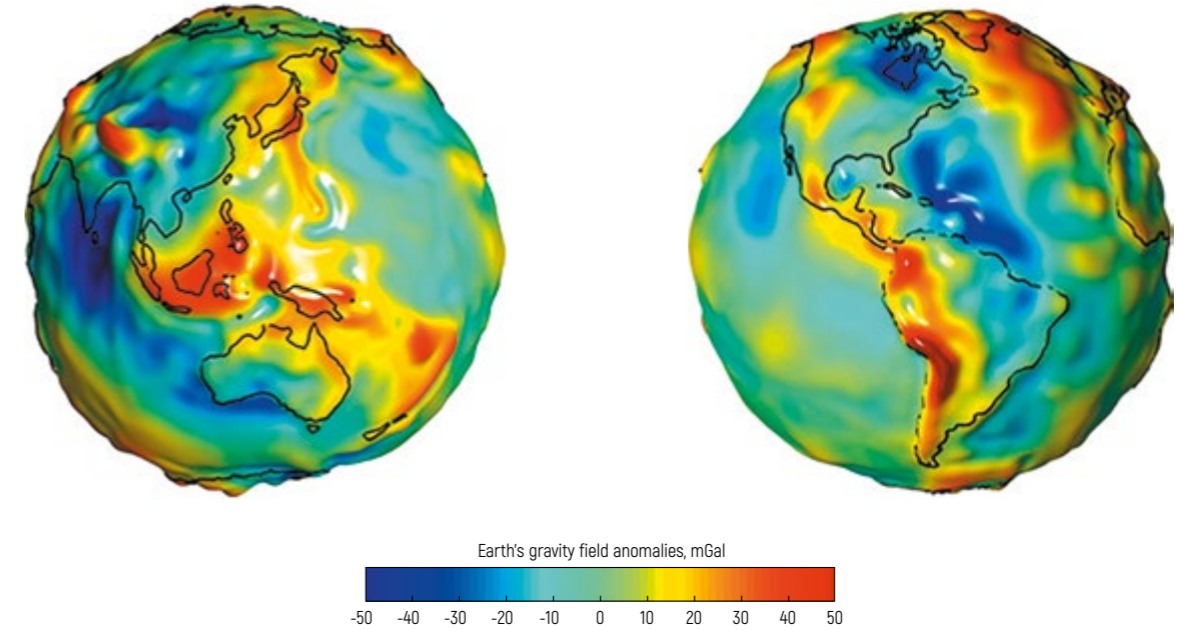

Figure 1 - Map of Earth's gravity field anomalies

Depending on the applied approaches to the description of equations and their solution, the created element is universal and allows modeling problems of both statics and dynamics.

equilibrium equation, which takes into account the effects of deformation of higher order of smallness:

$$([K_g] + [K_g] + [S_1] + [S_2] + [S_3])\{u\} = \{f^{second\ station}\} - \{f^{first\ station}\}, \quad (1)$$

where $[K_g]$ - linear stiffness matrix;
 $[K_g]$ - geometric stiffness matrix;
 $[S_1], [S_2], [S_3]$ - matrices allowing to take into account the effects of deformation of higher order of smallness in the element.

In turn, the matrices are obtained in the following form:

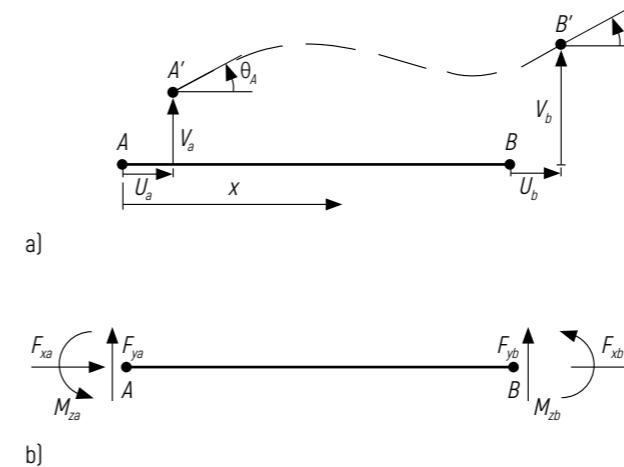

Figure 2 - Beam finite element:
a - displacement and the angles of nodes rotation;
b - force factors in nodes

$$K_g = \begin{bmatrix} \frac{EA}{L} & 0 & 0 & -\frac{EA}{L} & 0 & 0 \\ 0 & \frac{12EI}{L^3} & \frac{6EI}{L^2} & 0 & -\frac{12EI}{L^3} & \frac{6EI}{L^2} \\ 0 & \frac{6EI}{L^2} & \frac{4EI}{L} & 0 & -\frac{6EI}{L^2} & \frac{2EI}{L} \\ -\frac{EA}{L} & 0 & 0 & \frac{EA}{L} & 0 & 0 \\ 0 & -\frac{12EI}{L^3} & -\frac{6EI}{L^2} & 0 & \frac{12EI}{L^3} & -\frac{6EI}{L^2} \\ 0 & \frac{6EI}{L^2} & \frac{2EI}{L} & 0 & -\frac{6EI}{L^2} & \frac{4EI}{L} \end{bmatrix}, \quad (2)$$

When solving statics problems, the equation describing the behavior of the element corresponds to the incremental

$$K_g = \begin{bmatrix} \frac{F_{xb}}{L} & 0 & -\frac{M_{za}}{L} & -\frac{F_{xb}}{L} & 0 & -\frac{M_{zb}}{L} \\ 0 & \frac{6F_{xb}}{5L} + \frac{12F_{xb}}{AL^3} & \frac{F_{xb}}{10} + \frac{6F_{xb}}{AL^2} & 0 & -\frac{6F_{xb}}{5L} - \frac{12F_{xb}}{AL^3} & \frac{F_{xb}}{10} + \frac{6F_{xb}}{AL^2} \\ \frac{M_{za}}{L} & -\frac{F_{xb}}{10} - \frac{6F_{xb}}{AL^2} & \frac{2LF_{xb}}{15} + \frac{4F_{xb}}{AL} & \frac{M_{za}}{L} & -\frac{F_{xb}}{10} - \frac{6F_{xb}}{AL^2} & -\frac{LF_{xb}}{30} + \frac{2F_{xb}}{AL} \\ -\frac{F_{xb}}{L} & 0 & \frac{M_{za}}{L} & \frac{F_{xb}}{L} & 0 & \frac{M_{zb}}{L} \\ 0 & -\frac{6F_{xb}}{5L} - \frac{12F_{xb}}{AL^3} & -\frac{F_{xb}}{10} - \frac{6F_{xb}}{AL^2} & 0 & \frac{6F_{xb}}{5L} + \frac{12F_{xb}}{AL^3} & -\frac{F_{xb}}{10} - \frac{6F_{xb}}{AL^2} \\ -\frac{M_{zb}}{L} & \frac{F_{xb}}{10} + \frac{6F_{xb}}{AL^2} & -\frac{LF_{xb}}{30} + \frac{2F_{xb}}{AL} & -\frac{M_{zb}}{L} & \frac{F_{xb}}{10} + \frac{6F_{xb}}{AL^2} & \frac{2LF_{xb}}{15} + \frac{4F_{xb}}{AL} \end{bmatrix}, \quad (3)$$

$$S_1 = \begin{Bmatrix} F_{xan} \\ F_{yan} \\ M_{zan} \\ F_{xbn} \\ F_{ybn} \\ M_{zbn} \end{Bmatrix}, \quad (4)$$

$$S_2 = \begin{bmatrix} \frac{F_{xbl}}{L} & 0 & -\frac{M_{zal}}{L} & -\frac{F_{xbl}}{L} & 0 & -\frac{M_{zbl}}{L} \\ 0 & \frac{6F_{xbl}}{5L} + \frac{12F_{xbl}}{AL^3} & \frac{F_{xbl}}{10} + \frac{6F_{xbl}}{AL^2} & 0 & -\frac{6F_{xbl}}{5L} - \frac{12F_{xbl}}{AL^3} & \frac{F_{xbl}}{10} + \frac{6F_{xbl}}{AL^2} \\ \frac{M_{zal}}{L} & -\frac{F_{xbl}}{10} - \frac{6F_{xbl}}{AL^2} & \frac{2LF_{xbl}}{15} + \frac{4F_{xbl}}{AL} & \frac{M_{zal}}{L} & -\frac{F_{xbl}}{10} - \frac{6F_{xbl}}{AL^2} & -\frac{LF_{xbl}}{30} + \frac{2F_{xbl}}{AL} \\ -\frac{F_{xbl}}{L} & 0 & \frac{M_{zal}}{L} & \frac{F_{xbl}}{L} & 0 & \frac{M_{zbl}}{L} \\ 0 & -\frac{6F_{xbl}}{5L} - \frac{12F_{xbl}}{AL^3} & -\frac{F_{xbl}}{10} - \frac{6F_{xbl}}{AL^2} & 0 & \frac{6F_{xbl}}{5L} + \frac{12F_{xbl}}{AL^3} & -\frac{F_{xbl}}{10} - \frac{6F_{xbl}}{AL^2} \\ -\frac{M_{zbl}}{L} & \frac{F_{xbl}}{10} + \frac{6F_{xbl}}{AL^2} & -\frac{LF_{xbl}}{30} + \frac{2F_{xbl}}{AL} & -\frac{M_{zbl}}{L} & \frac{F_{xbl}}{10} + \frac{6F_{xbl}}{AL^2} & \frac{2LF_{xbl}}{15} + \frac{4F_{xbl}}{AL} \end{bmatrix}, \quad (5)$$

$$S_3 = \begin{bmatrix} \frac{F_{xbl}}{L} & 0 & -\frac{M_{zal}}{L} & -\frac{F_{xbl}}{L} & 0 & -\frac{M_{zbl}}{L} \\ 0 & \frac{6F_{xbl}}{5L} + \frac{12F_{xbl}}{AL^3} & \frac{F_{xbl}}{10} + \frac{6F_{xbl}}{AL^2} & 0 & -\frac{6F_{xbl}}{5L} - \frac{12F_{xbl}}{AL^3} & \frac{F_{xbl}}{10} + \frac{6F_{xbl}}{AL^2} \\ \frac{M_{zal}}{L} & -\frac{F_{xbl}}{10} - \frac{6F_{xbl}}{AL^2} & \frac{2LF_{xbl}}{15} + \frac{4F_{xbl}}{AL} & \frac{M_{zal}}{L} & -\frac{F_{xbl}}{10} - \frac{6F_{xbl}}{AL^2} & -\frac{LF_{xbl}}{30} + \frac{2F_{xbl}}{AL} \\ -\frac{F_{xbl}}{L} & 0 & \frac{M_{zal}}{L} & \frac{F_{xbl}}{L} & 0 & \frac{M_{zbl}}{L} \\ 0 & -\frac{6F_{xbl}}{5L} - \frac{12F_{xbl}}{AL^3} & -\frac{F_{xbl}}{10} - \frac{6F_{xbl}}{AL^2} & 0 & \frac{6F_{xbl}}{5L} + \frac{12F_{xbl}}{AL^3} & -\frac{F_{xbl}}{10} - \frac{6F_{xbl}}{AL^2} \\ -\frac{M_{zbl}}{L} & \frac{F_{xbl}}{10} + \frac{6F_{xbl}}{AL^2} & -\frac{LF_{xbl}}{30} + \frac{2F_{xbl}}{AL} & -\frac{M_{zbl}}{L} & \frac{F_{xbl}}{10} + \frac{6F_{xbl}}{AL^2} & \frac{2LF_{xbl}}{15} + \frac{4F_{xbl}}{AL} \end{bmatrix}, \quad (6)$$

where E - modulus of elasticity;

A - cross-sectional area;

L - element length;

I - moment of inertia;

$F_{xan}, F_{yan}, F_{xbl}, F_{ybl}, F_{xal}, F_{yal}, F_{xbl}, F_{ybl}, M_{zal}, M_{zbl}, M_{zan}, M_{zbn}$ - components of forces and moments included in the composition of matrices [2]-[6] (described in [7], [8]);

indices a and b - load application at node a or b (Figure 2); x, y, z - coordinate axes; n and l - nonlinear and linear components of forces.

$$\begin{aligned} F_{xal} &= -EA \frac{u_b - u_a}{L}, \\ F_{yal} &= \frac{EI}{L^3} (12v_a + 6\theta_a L - 12v_b + 6\theta_b L), \\ M_{zal} &= \frac{EI}{L^2} (6v_a + 4\theta_a L - 6v_b + 2\theta_b L), \\ F_{xbl} &= -F_{xal}, \\ F_{ybl} &= -F_{yal}, \\ M_{zbl} &= \frac{EI}{L^2} (6v_a + 2\theta_a L - 6v_b + 4\theta_b L), \end{aligned} \quad (7)$$

$$\begin{aligned} F_{xan} &= -\frac{1}{2}EA \left(\frac{u_b - u_a}{L} \right)^2 - \frac{EA}{2L^2} \left(\frac{6}{5}v_a^2 + \frac{2}{15}\theta_a^2 L^2 + \frac{6}{5}v_b^2 + \frac{2}{15}\theta_b^2 L^2 + \frac{1}{5}v_a\theta_a L - \frac{12}{5}v_a v_b + \frac{1}{5}v_a\theta_b L - \frac{1}{5}v_b\theta_a L - \frac{1}{15}\theta_a\theta_b L^2 - \frac{1}{15}v_b\theta_b L \right) - \\ &\quad - \frac{2EI}{L^4} (3v_a^2 + \theta_a^2 L^2 + 3v_b^2 + \theta_b^2 L^2 + 3v_a\theta_a L - 6v_a v_b + 3v_a\theta_b L - \\ &\quad - 3v_b\theta_a L + \theta_b\theta_b L^2 - 3v_b\theta_b L), \\ F_{yan} &= \frac{EI}{L^3} \left(\frac{u_b - u_a}{L} \right) (12v_a + 6\theta_a L - 12v_b + 6\theta_b L), \\ M_{zan} &= \frac{EI}{L^2} \left(\frac{u_b - u_a}{L} \right) (6v_a + 4\theta_a L - 6v_b + 2\theta_b L), \\ F_{xbn} &= -F_{xan}, \\ F_{ybn} &= -F_{yan}, \\ M_{zbn} &= \frac{EI}{L^2} \left(\frac{u_b - u_a}{L} \right) (6v_a + 2\theta_a L - 6v_b + 4\theta_b L), \end{aligned} \quad (8)$$

where u_a, u_b - movement of nodes along the X axis;

v_a, v_b - movement of nodes along the Y axis;

θ_a, θ_b - angles of nodes rotation (Figure 2).

In order to solve equation (1), the Newton-Raphson method in full formulation [5], which is an iterative numerical

method for finding the root of a given function, also known as the tangent method, has been added to the software package. The calculation is performed by constructing successive approximations and is based on the principles of simple iteration.

This method has quadratic convergence and can be represented for the solver of the program complex in the following form:

$$\Delta u^n = (F_{ext} - F_{int}^n) / K^n, \quad (9)$$

$$F_{res} = F_{ext} - F_{int}^n, \quad (10)$$

$$F_{res}^n \leq \text{convergence criterion}, \quad (11)$$

where Δu^n - displacement increment at iteration;

F_{ext} - applied load;

F_{int}^n - calculated internal force;

K_n - system stiffness;

F_{res}^n - difference of two forces (force criterion).

The dynamic behavior of the element is described by the basic equation of dynamics given in matrix form:

$$[M]\{\ddot{u}\} + [C]\{\dot{u}\} + F_{int}\{u\} = F_{ext}, \quad (12)$$

where $[M]$ - mass matrix of beam element;

$[C]$ - damping matrix.

To solve the dynamics problems, the Newmark method was applied, which can be represented as follows:

$$\begin{aligned} \dot{u}_{n+1} &= \dot{u}_n + \Delta t \ddot{u}_n, \\ \ddot{u}_n &= (1 - \gamma) \ddot{u}_n + \gamma \ddot{u}_{n+1}, \\ \dot{u}_{n+1} &= \dot{u}_n + (1 - \gamma) \Delta t \ddot{u}_n + \gamma \Delta t \ddot{u}_{n+1}, \\ u_{n+1} &= u_n + \Delta t \dot{u}_n + \frac{1}{2} \Delta t^2 \ddot{u}_n, \\ \ddot{u}_n &= (1 - 2\beta) \ddot{u}_n + 2\beta \ddot{u}_{n+1}, \\ \dot{u}_{n+1} &= (1 - \gamma) \Delta t \ddot{u}_n + \gamma \Delta t \ddot{u}_{n+1}, \\ u_{n+1} &= u_n + \Delta t \dot{u}_n + \frac{\Delta t^2}{2} [(1 - 2\beta) \ddot{u}_n + 2\beta \ddot{u}_{n+1}], \end{aligned} \quad (13)$$

$$\gamma = 0.5,$$

$$\beta = 0.25,$$

where u, \dot{u}, \ddot{u} - displacement, speed, acceleration;

Δt - time step.

To develop the product, the high-level Python programming language is used together with a number of special libraries. The indicator of program execution are data arrays as well as their graphical visualization. The Numpy library was used to create matrices and work with them, the Matplotlib library – to visualize the results. Ready-made libraries for implementing the finite element method were not used in the development of the current product, since there is no sufficient data on their accuracy or detailed description of the method implemented in them relatively to Python.

The designed program product consists of several modules, each of which performs a number of functions:

- module for creating geometry and describing material properties – for editing the input geometry;
- grid preprocessor module – for representing the geometric model as a mathematical one;
- module for applying loads and boundary conditions – for setting the conditions of the calculation;
- module for solving – the solver that performs necessary mathematical calculations;
- module for interpretation and visualization of results – for graphical interpretation of the solver results.

Verification of Obtained Results

The correctness of the developed element was verified based on calculations of three basic mechanics problems, followed by comparison of the results with alternative solutions.

1. Calculation of a long cantilever beam ($L = 2.5$ m) of square cross section (50×50 mm) loaded at the end with a concentrated force ($F = 5,000$ N) (Figure 3). The material is steel, modulus of elasticity $E = 200,000$ MPa, Poisson's ratio $\nu = 0.3$. The results of modeling are presented in Figure 4.

It should be noted that the problem of a cantilever beam is chosen for finite element verification because the height to length ratio of the beam is $1/50$ and has nonlinear behavior (large deformations). Figure 4 shows the deformation of the beam under a specified force. The maximum deflection at the end of the beam was 247.53 mm.

2. Calculation of a structure in the form of two rods rigidly constrained at the ends. At the midpoint, the rods are connected with a lift of 9.8 mm. Geometric dimensions are shown in Figure 5. The material of the rods is aluminum, modulus of elasticity $E = 70,922$ MPa, Poisson's ratio $\nu = 0.2$, load $F = 310$ N. The results of modeling are presented in Figure 6.

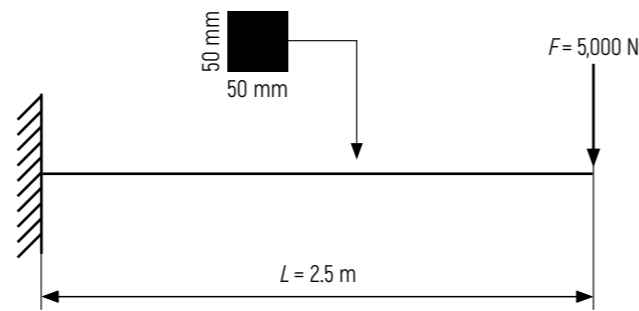

Figure 3 – Calculation diagram of problem 1. Cantilever beam (static positioning)

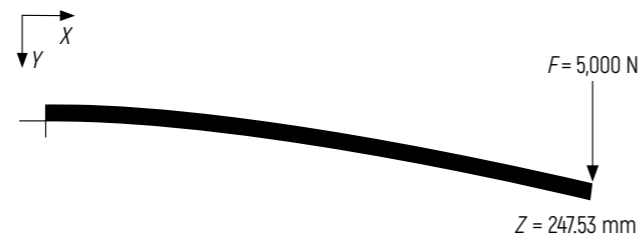

Figure 4 – Vertical deflection of a cantilever beam (static positioning)

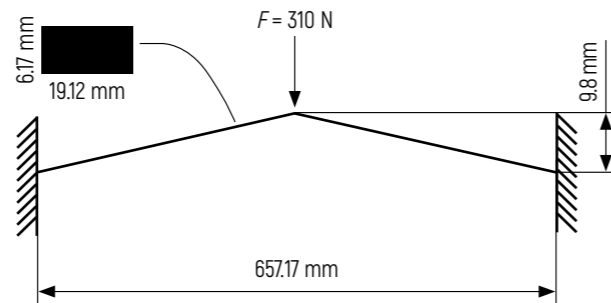

Figure 5 – Calculation diagram of problem 2, geometrical dimensions of the sample. Classical problem with a thrust (static positioning)

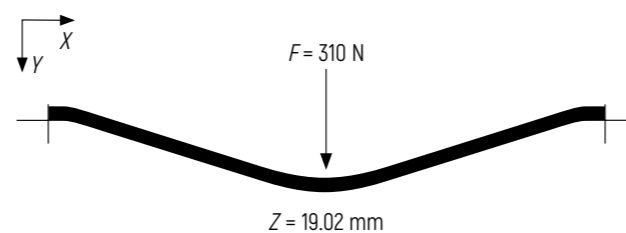

Figure 6 – Vertical deflection of a structure made of two rods (static positioning)

Such a problem is important because in the process of deformation there is a nonlinear change in the stiffness of the structure and a change in the forces in the bars (thrust). Figure 6 shows the deformation of beams under the action of a specified force. The maximum deflection in the middle of the span was 19.02 mm.

3. To check the correctness of the dynamic component of the solution, the problem of vibrations of a cantilever beam (dynamic positioning) of square cross section (50×50 mm) loaded at the end with a concentrated constant force ($F = 5,000$ N) (Figure 7) was used. The material is steel, modulus of elasticity $E = 200,000$ MPa, structural damping coefficient $\xi = 0.01$. Figures 8 and 9 show the results of modeling as well as the dynamic behavior of the cantilever beam loaded with a constant force. Figure 9 is a graphical representation of vibrations at the free end of the beam. As can be seen, the maximum deflection is 376.05 mm. After damping, its value coincides with that obtained in static problem 1.

The Table shows the results of modeling with the help of the developed software product, ANSYS analysis system and analytical method.

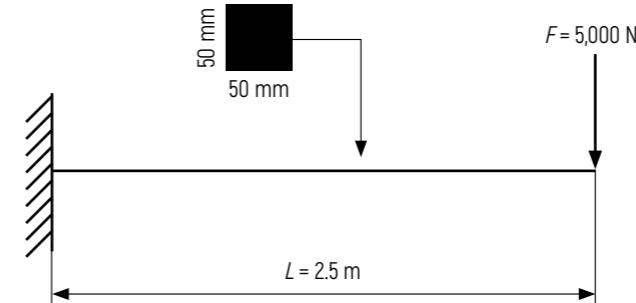

Figure 7 – Calculation diagram of problem 3. Cantilever beam (dynamic positioning)

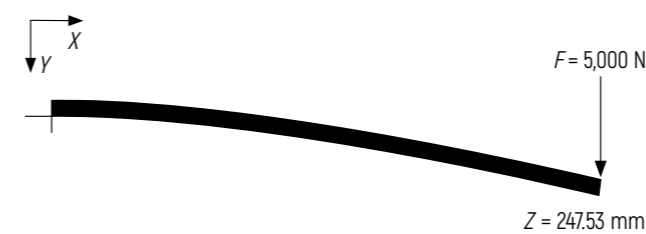

Figure 8 – Vertical deflection of a cantilever beam in end position after damping (dynamic positioning)

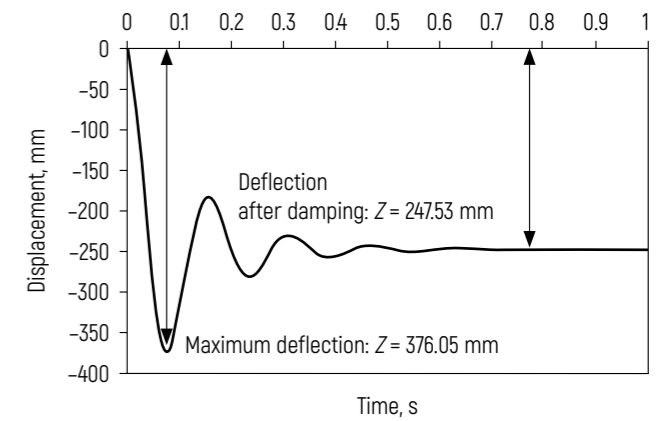

Figure 9 – Dynamic response of a cantilever beam loaded with a constant force

Table – Results of modeling

Indicator	Problem number	Software product under development	ANSYS	Analytical solution
Vertical displacement, mm	1	247.53	247.84	247.67
	2	19.02	19.36	19.27
Dynamic deflection, maximum value, mm	3	376.05	376.75	376.32
Dynamic deflection, value after damping, mm	3	247.53	247.84	247.67

The results obtained using this software package have a sufficient degree of accuracy compared to other available methods of calculations. It is noteworthy that the performed calculation is only a variant of the product application for solving the GPV problems, and with the help of the final version it is possible to carry out the calculations for a variety of problems of solid mechanics. The practical result is the use of the package for modeling of the GPV behavior under various operating modes, forecasting risks and assessing probable ways to avoid them.

Approbation of Obtained Results

The Unitsky String Transport (uST) is an integral part of the designed GPV; respectively, models of string rail track structures can be accepted as prototypes for solving problems related to the GPV elements. This statement allowed to test the software package on a real object: dynamic modeling of the passage and selection of the movement trajectory were performed when designing one of the string transport lines.

The cross-sectional appearance of the track structure is shown in Figure 10. Its geometric and physical characteristics: weight of the lower belt – 84 kg/lin m; weight of the upper belt – 15.5 kg/lin m; length – 720 m; installation tension, lower belt – 5,730 kN; installation tension, upper belt – 1,860 kN; total tension – 7,240 kN; suspension pitch – 3 m.

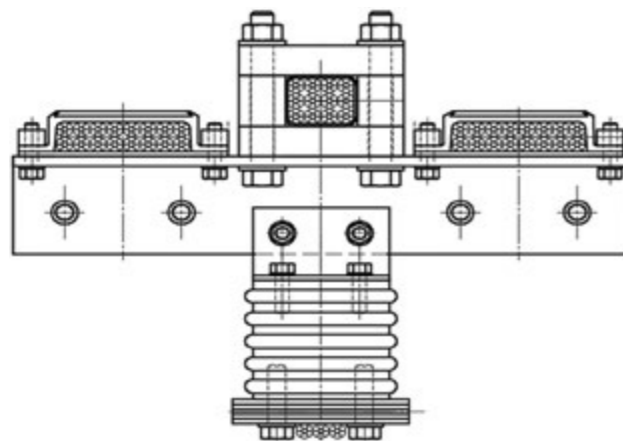

Figure 10 – Cross section of track structure

Figure 11 shows a simplified transport model. Its mechanical characteristics: total stiffness of the first stage of spring suspension – 220 N/mm; total stiffness of the second stage of spring suspension – 520 N/mm; damping of the first stage of spring suspension – 9 N·s/mm; travel speed – 60–100 km/h; first natural frequency of the suspension – 1.05 Hz; weight – 8–24 tons.

Previous string transport projects allowed to accumulate considerable experience as well as a sufficient amount of experimental data. Taking into account that the GPV elements can be based on existing solutions for string rail track structure models, the approbation of the created product on the basis of available information was carried out.

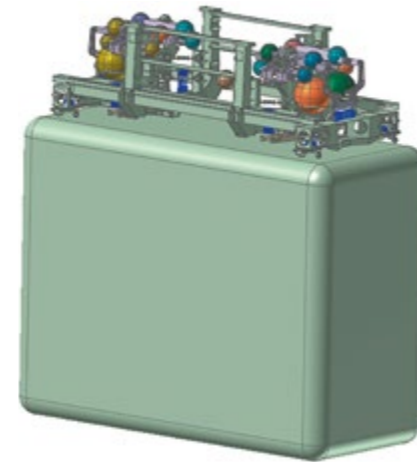

Figure 11 – Simplified model of a vehicle (uPod)

The basic scope of problems in the considered case is related to the selection of the uPod motion trajectory, at which vertical accelerations comfortable for the travel of people occur in the passenger module. The results of modeling are presented in Figures 12 and 13.

As a practical application of the software package for problems related to modeling of the GPV behavior, kinematic calculations of displacement, velocity and acceleration of the segmental section of this aircraft have been carried out (Figure 14). The characteristics obtained using the finite element method (Figure 15) fully correspond to those calculated earlier by A. Unitsky using the analytical method [1, 2].

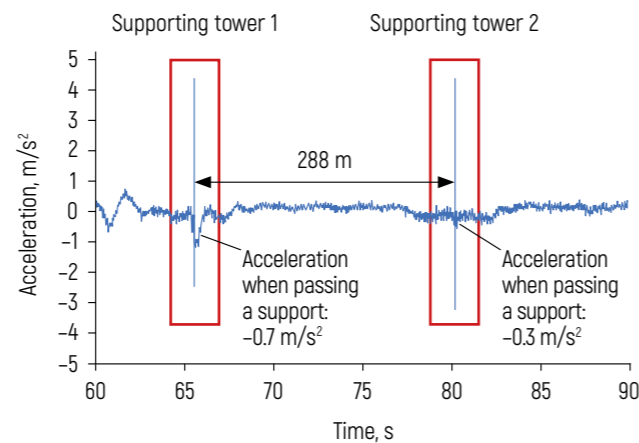

Figure 12 – Dynamic response in the passenger module (uPod weight 8,000 kg, travel speed 100 km/h; vertical component)

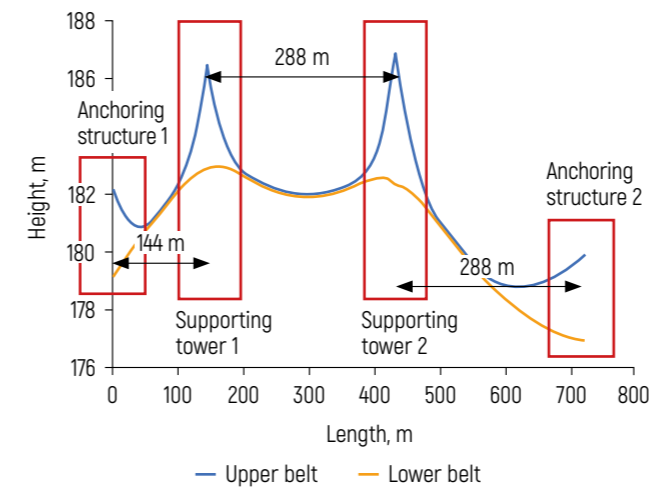

Figure 13 – Obtained optimal trajectory of transport motion

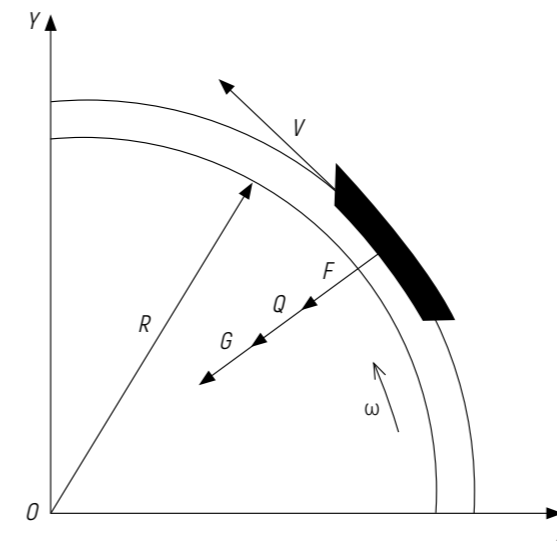
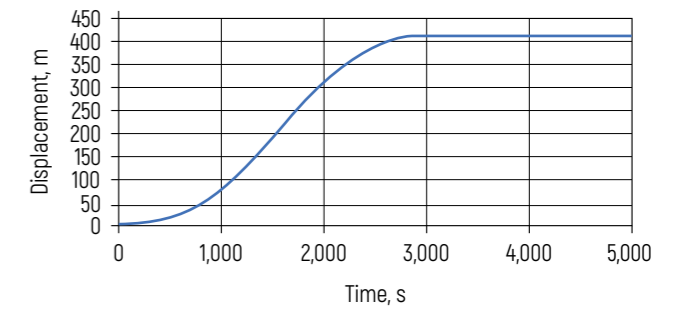

Figure 14 – Calculation diagram for determining kinematic characteristics (dynamic formulation of the problem): V – takeoff speeds of the GPV components; R – Earth radius; G – Earth's gravitational force; Q – atmospheric drag force; F – GPV elasticity force; ω – Earth's angular velocity

Conclusion

The developed beam finite element based on the Euler-Bernoulli element, when supplemented with a functional of the geometric stiffness matrix and deformation matrices of higher order of smallness, makes it possible to take into account geometric nonlinearity (large deformations), which makes it possible to model nonlinearities affecting the GPV behavior.



a)

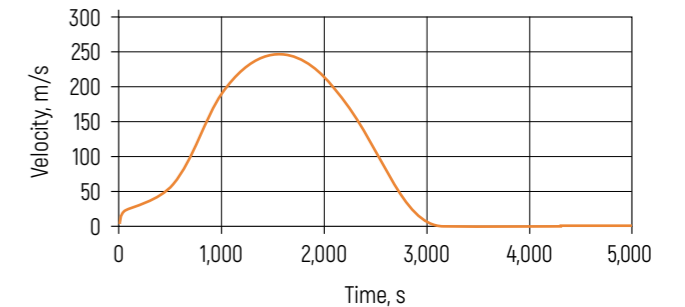

b)

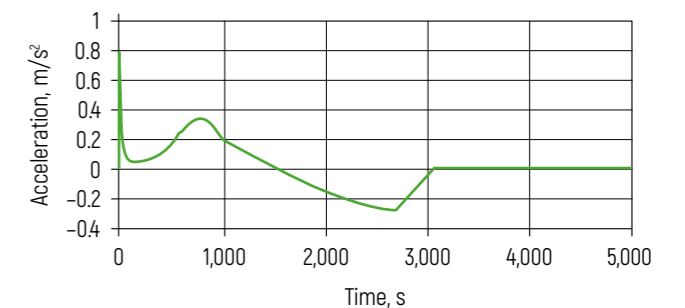

c)

Figure 15 – Obtained kinematic characteristics: a – vertical displacement of the GPV segment; b – vertical velocity of the GPV segment; c – vertical acceleration of the GPV segment

The results of the test problems were compared both with those obtained by the analytical (exact) method and with those calculated by the commercial finite element product ANSYS. The calculation problems demonstrate that the created finite element provides good accuracy and stability of the solution.

The software package has been tested while designing string transport, which confirms the correctness

of the experimental results. This development was used to verify kinematic characteristics within the framework of the GPV problems.

In the future, this software package will be used to optimize the requirements applied to the GPV elements for efficient and safe operation of this giant geocosmic aircraft: permissible unevenness of thrust of linear electric motors; permissible unevenness of the GPV loading along its length with passengers and cargo; permissible unevenness of efficiency factor of linear electric motors along its length and in time; permissible horizontal and vertical deviations of the GPV body (and the linear flywheels moving inside at cosmic velocities) from the shape of an ideal circle, etc.

References

1. *Unitsky, A.E. Sozdaniye matematicheskoy modeli obshcheplanetarnogo transportnogo sredstva s optimizatsiyey polozheniya i uchotom vliyaniya dinamicheskikh faktorov [Creation of a Mathematical Model of the General Planetary Vehicle with Position Optimization and Taking into Account the Effect of Dynamic Factors] / A.E. Unitsky, R.A. Sharshov, A.A. Abakumov // Bezraketnaya industrializatsiya blizhnego kosmosa: problemy, idei, proyekty: Collection of Articles of the III International Scientific and Technical Conference, Maryina Gorka, Sep. 12, 2020 / Astroengineering Technologies LLC, Unitsky String Technologies Inc.; ed. A. Unitsky. – Minsk: StroyMediaProyekt, 2021. – P. 182–193.*
2. *Unitsky, A. Creating a Mathematical Model of the General Planetary Vehicle: Accelerating Flywheels, Passing the Atmosphere, Going into Orbit / A. Unitsky, R. Sharshov, A. Abakumov // Non-Rocket Space Industrialization: Problems, Ideas, Projects: Collection of Articles of the II International Scientific and Technical Conference, Maryina Gorka, Jun. 21, 2019 / Astroengineering Technologies LLC; ed. A. Unitsky. – Minsk: Paradox, 2019. – P. 77–83.*
3. *Unitsky, A.E. Strunnyye transportnyye sistemy: na Zemle i v Kosmose [String Transport Systems: On Earth and in Space] / A.E. Unitsky. – Minsk: Bielaruskaja navuka, 2017. – 342 p.: ill.*
4. *Kim, N.-H. Introduction to Nonlinear Finite Element Analysis / N.-H. Kim. – New York: Springer, 2018. – 437 p.*
5. *Reddy, J.N. An Introduction to Nonlinear Finite Element Analysis: With Applications to Heat Transfer, Fluid Mechanics and Solid Mechanics / J.N. Reddy. – 2nd ed. – New York: Oxford University Press, 2015. – 768 p.*



UDC 004.942:537.6

Modeling the Dynamics of Magnetic System of Power Stabilizing Unit of the General Planetary Vehicle

A. Unitsky^{1,2}
Dr. of Philosophy
in Information Technologies
(Transport)

A. Khlebus²

¹ Astroengineering Technologies LLC,
Minsk, Belarus

² Unitsky String Technologies Inc.,
Minsk, Belarus



It is proposed an implementation of the magnetic system of the stabilizing unit (MSSU) for the linear rotors of the General Planetary Vehicle (GPV) based on permanent neodymium magnets, which ensures retention and stabilization of the rotors in the vacuum channels of the stator in all operating modes of the GPV. The force loading of the elements of the stabilizing unit from the action of longitudinal and transverse electromagnetic forces is determined. A computer model of the MSSU is presented and simulation modeling of the system's functioning in various dynamic modes is carried out in order to assess its performance and the possibility of application in the GPV design.

Keywords:

General Planetary Vehicle (GPV), magnetic forces, magnetic levitation, magnetic system of the stabilizing unit (MSSU), neodymium magnets, simulation modeling.

Introduction

Due to the global scale of the General Planetary Vehicle (GPV), which is an enclosed ring structure with a length of more than 40,000 km, the main requirements for its design are high performance and efficiency. Performance should ensure the delivery to near-Earth orbit of up to 10 mln tons of cargo and up to 10 mln passengers per flight [1], which is equivalent to a load capacity of about 250 kg/lin m. Efficiency will primarily be determined by low energy consumption in all modes of the GPV operation and the high efficiency factor of all components and mechanisms of this giant geocosmic aircraft.

One of the most significant features of the GPV design is the use of magnetic suspension for the rotors. It should ensure a safe gap between movable and fixed components, both in static and dynamic conditions, when the speed of the rotors reaches 12 km/s [2]. At present, it is proposed to employ the principles of levitation using electromagnetic forces to address this complex engineering challenge. We know various types of such systems, based on electromagnetic and electrodynamic levitation as well as levitation over a superconductor [3]. However, all these systems have significant drawbacks, including the requirement for a constant power supply, the duplication of control system components and their high energy consumption.

At the same time, there is a well-developed magnetic suspension system for the GPV linear rotors. This system consists only of permanent magnets and is completely autonomous, requiring neither a large amount of energy nor a control system to operate. Its main disadvantage is the need for cooling. However, the contradiction of the Earnshaw's theorem [4], which states that it is impossible to create a system of permanent magnets that provide levitation without affecting the body with other forces than magnetic, is excluded due to the design characteristics of the GPV [3]. Its feature is that both the rotors and the stator consist of individual segments that are tightly interconnected, which is required to assemble the GPV structure and increase its circumferential length (stretching) by 6.5 % as it climbs to a height of approximately 400 km from the launch surface [5]. Being in an enclosed structure, adjacent segments exert the same external influence on each other, making magnetic levitation possible. The proposed system should automatically stabilize the position of the movable rotors in the vacuum channels of the stator in all modes of the GPV operation in the event of forces of any nature seeking to deflect the body of the aircraft from its normal position in any direction.

The aim of the research is to use simulation modeling to determine the possibility of implementing the magnetic system of the stabilizing unit (MSSU) for the linear rotors of the GPV, consisting only of permanent magnets, and create a computer-generated dynamic model of the MSSU that would allow us to assess the effectiveness of the system and its ability to resist external destabilizing forces.

Design of the Power Unit Based on Permanent Neodymium Magnets

The climbing of the GPV as an enclosed ring structure into near-Earth orbit is possible due to the centrifugal force generated by the rotation of the main linear rotor (rotor 1) (Figure 1). At the point when the GPV separates from the take-off and landing overpass and the highest gravity acts on all components, maximum electromagnetic repulsive forces arise in the upper power units of the MSSU of the linear rotor 1 and the stator, preventing physical contact between the movable and fixed parts of the GPV.

To calculate the peak values of the interaction forces between the linear rotor and the linear stator, the following component masses will be used, which are provided in [6], as an input: for the rotor 1 the value is 450 kg/lin m, for the auxiliary rotor (rotor 2) – 200 kg/lin m, for the GPV body and the stator together with the payload – 500 kg/lin m.

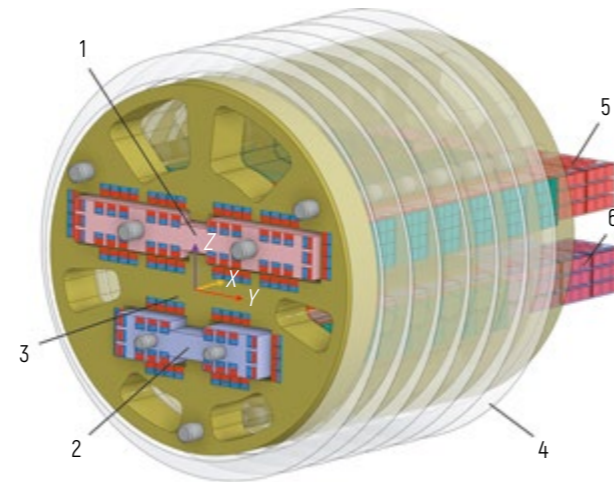

Figure 1 – Key linear components in the GPV design:
1 – linear rotor 1; 2 – linear rotor 2;
3 – linear stator; 4 – GPV body;
5 – magnetic system of the rotor 1;
6 – magnetic system of the rotor 2

Because of the complexity of the GPV longitudinal axis trajectory in the equatorial plane, which differs from the circle due to the terrain on land and the geoid shape of the planet in oceanic sections, the separation of the GPV from the overpass will be uneven and accompanied by transient dynamic processes, which will add an inertial component to the forces of interaction between the rotor and the stator. At this stage, it is quite laborious to predict their value, this is an independent engineering task. Therefore, it will be taken into account the inertial loads by using the dynamic coefficient C_d equal to 2. The maximum value of the equivalent load from the action of electromagnetic forces in the contact of the rotor 1 and the stator will be equal to:

$$q_{M_{max}} = (m_2 + m_3)gC_d = (200 + 500) \times 9.78 \times 2 = 13,692 \text{ N/lin m}, \quad (1)$$

where m_2 – linear mass of the rotor 2, kg/lin m;

m_3 – linear mass of the body, stator and payload, kg/lin m;

g – acceleration of gravity at the equator, 9.78 m/s²;

C_d – dynamic coefficient.

The MSSU of linear rotors must ensure that there is a safe gap in the YZ plane in all operating modes of the GPV and when various destabilizing external and internal forces are applied to its body. At the same time, it should not interfere with the movement of the rotors along the X-axis (Figure 1). Taking this into account, there is a requirement for a relative uniformity of the magnetic field along the axis of motion of the rotors in vacuum channels, which should not significantly alter its power characteristics even with an increase in the GPV circumferential length to 6.5 %.

All the abovementioned requirements and design features of the GPV have led to the search for a technical solution to practically implement the linear rotors MSSU. As a primary component of the system, it is proposed to use a universal power unit that is a magnetic assembly of discrete neodymium magnets of the N52H brand with a cubic shape measuring 25 × 25 × 25 mm (Figure 2). The design of this unit has been developed based on numerous technical and technological requirements and optimization results in specialized software that allows calculating the magnitude of the force interaction of permanent magnets.

The operation of the MSSU power unit rests upon the repulsion of two mutually directed magnetic groups – the stator (fixed part) and the rotor (movable part relative to the stator). Each group is an array of discrete cubic magnets with a size of 25 × 25 × 25 mm: a 4 × 4 array with a Gap_{ST} = 1 mm for the stator, and a 3 × 3 array with a Gap_R = 8 mm for the rotor. The values of the Gap_{ST} and Gap_R were determined based on the results of optimization according to the criterion

of minimal influence on the normal component of the magnetic force F_{MN} (along the Z-axis) with a relative displacement of the groups along the X- and Y-axes (Figure 2).

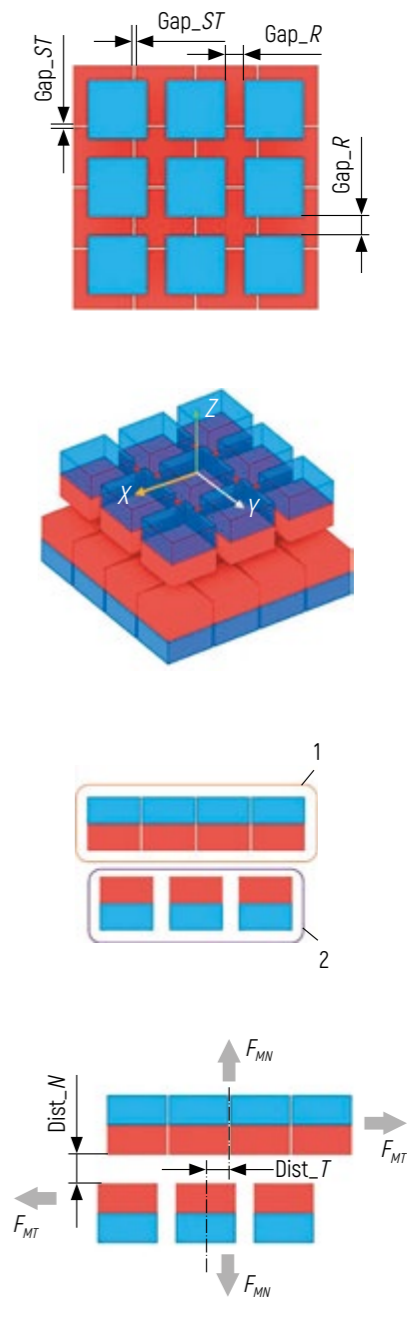

Figure 2 – Construction of a magnetic assembly power unit made of discrete neodymium magnets: a – top view; b – isometric view; c – side view at the nominal position of the magnetic groups; d – side view at the tangential displacement of the magnetic groups; 1 – stator magnetic group; 2 – rotor magnetic group

The main advantages of the proposed design of the MSSU power unit are:

- slight change in the normal repulsive force with a tangential displacement of the magnetic groups of the stator and the rotor relative to each other based on the electromagnetic forces calculation results performed in specialized software;
 - variability in the power characteristics of magnets does not affect the uniformity of the magnetic field at the contact of the stator and rotor components, which ensures the safe operation of the MSSU, even in the event of a single discrete magnet losing its magnetization [7];
 - ease of manufacture and relatively weak interaction forces of small magnets determine the convenience of technological assembly as well as the possibility of automation and parallel production of power units, which would significantly save time required for the implementation of a non-rocket space exploration project;
 - small linear dimensions of the magnetic group cause a slight increase in the gap between adjacent segments when the GPV structure is stretched in climbing mode, which also affects the uniformity of the magnetic field and the constancy of electromagnetic forces between the rotors and the stator;
 - versatility – convenience of layout and interchangeability in the overall structure of the GPV.
- Among the disadvantages of the presented design, the following can be noted:
- the cooling system as the main safety system is mandatory, since the operability of permanent neodymium magnets of the N52H brand is maintained up to 120 °C, after which demagnetization occurs;
 - the large-scaled GPV structure will require a significant number of permanent neodymium magnets (more than 100 bln pcs). Their production will utilize expensive rare earth elements, namely about 4 mln tons of neodymium, which represents approximately 4 % of its world's reserves. In addition, appropriate industrial capacities will be needed. At present, 95 % of the global market for the production and distribution of neodymium belongs to China [8].

Determination of the Normal and Tangential Magnetic Forces of the Power Unit Elements Interaction

The dynamics of the MSSU power unit operation will directly depend on the inertial and electromagnetic forces

that arise during the interaction between magnetic groups at any given moment in time. The inertial forces depend on the mass-inertial characteristics of the GPV elements and the acceleration tensors affecting these elements. Electromagnetic forces have a different origin and are caused by the intensity of the magnetic field produced in space by a system of magnets with a specific orientation and coercivity [9].

Initially, the motion of the magnetic groups of a power unit's rotor and stator relative to each other is characterized by three translational degrees of freedom and three rotational ones. However, due to the GPV design features and the use of several mutually compensating power units to implement each rotor's MSSU, the rotational degrees of freedom of each of them can be ignored, since the relative rotations of the magnetic groups are negligible.

Let us look at the translational degrees of freedom relative to the three axes (Figure 2). The X -axis is the axis of the rotors motion, in the direction of which the linear electric motor accelerates/decelerates the segments of the rotor enclosed in an annular structure; the total force from permanent magnets $F_M \approx 0$ due to the interaction between neighboring segments. The Y -axis corresponds to the tangential displacement of one magnetic group relative to another and is determined by the total tangential force F_{MT} . The Z -axis corresponds to the displacement of one magnetic group relative to another along the normal to the conditional contact plane and is determined by the total normal force F_{MN} , which defines the elasticity of the power unit. The complexity of the analytical calculation of the magnetic forces F_{MT} and F_{MN} is associated with the heterogeneity of the magnetic induction distribution fields, which strongly depends on the displacement distance of the magnetic groups $Dist_T$ and $Dist_N$ along the Y - and Z -axes respectively.

The calculation was performed with specialized software that allows to find the magnitude of magnetic forces according to the given materials and 3D models of magnetic assembly. The calculation results are presented in Tables 1, 2 and will be used further to simulate the dynamics of the GPV MSSU under the influence of destabilizing transverse and vertical forces.

As can be seen from Table 1, the greater the tangential displacement of the magnetic groups relative to the zero position, the larger the shear force exerted on them. Therefore, when assembling power units, certain initial displacement is incorporated into the design of the GPV in order to mutually compensate for transverse forces and minimize their destabilizing effects in the event of lateral deviations of the rotors.

Table 1 – Dependence of the magnitude of the shearing force of the magnetic groups of one F_{MT} power unit on the tangential and normal displacements. The force is applied to an area equivalent to 0.01 m²

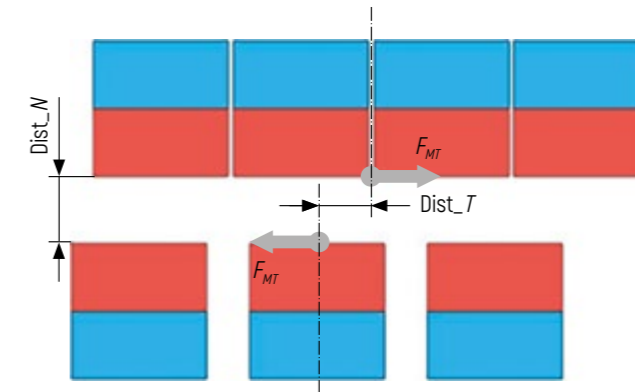

F_{MT}, N	Displacement normal to the contact plane $Dist_N, mm$																				
	20.5	19.5	18.5	17.5	16.5	15.5	14.5	13.5	12.5	11.5	10.5	9.5	8.5	7.5	6.5	5.5	4.5	3.5	2.5	1.5	0.5
0	0	0	0	0	0	0	0	0	0	0	0	0	0	0	0	0	0	0	0	0	0
1	9	9	9	10	11	12	13	14	14	16	16	17	18	20	22	22	23	23	26	23	27
2	18	19	20	20	22	24	26	27	28	31	33	35	37	40	42	43	45	47	48	47	47
3	26	28	30	31	33	35	38	40	43	46	49	53	55	59	64	66	70	72	74	74	70
4	35	37	38	42	44	47	51	55	56	61	64	69	74	79	84	89	95	100	102	103	96
5	42	45	49	51	54	58	62	66	70	76	82	87	93	99	106	113	120	127	133	138	132
6	51	54	57	61	64	69	74	80	85	90	96	103	111	118	127	137	145	155	165	173	176
7	59	62	66	70	75	80	85	91	97	104	111	119	129	137	147	157	168	182	196	212	235
8	67	71	75	80	85	90	96	101	110	117	125	135	144	155	167	180	194	209	228	250	281
9	74	78	83	89	94	100	106	114	122	129	140	149	160	173	185	201	217	235	256	282	315
10	81	87	92	96	104	110	117	125	134	143	153	164	176	190	204	221	239	259	283	308	342
11	88	93	99	105	112	118	126	134	144	154	165	175	190	204	221	238	258	280	305	330	360
12	94	101	107	112	119	126	136	144	154	163	175	189	202	218	235	254	276	299	324	353	380
13	102	107	113	120	127	134	144	153	163	174	185	199	213	230	248	268	288	313	338	367	399
14	107	113	119	126	135	142	151	161	171	182	195	209	224	241	259	279	302	323	349	379	416

The data in Table 2 confirm that there is a rather small change in the normal repulsive force with a tangential displacement of the magnetic groups in the stator and the rotor relative to each other, which ensures

the constancy of the elastic properties of the power unit even with lateral deviations of the rotors. This is one of the main optimization criteria for selecting the layout of magnetic groups.

Table 2 – Dependence of the magnitude of the normal repulsive force of the magnetic groups of one F_{MN} power unit on the tangential and normal displacements. The force is applied to an area equivalent to 0.01 m^2

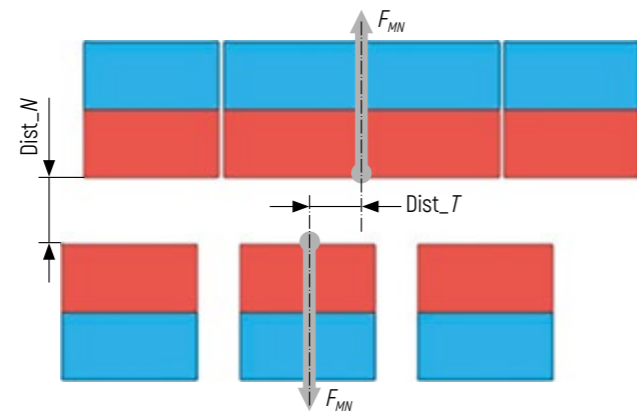

F_{MN} , N	Displacement along the contact plane $Dist_T$, mm														
	0	1	2	3	4	5	6	7	8	9	10	11	12	13	14
20.5	379	378	377	376	374	372	371	366	364	359	354	349	345	339	333
19.5	397	396	395	394	392	391	387	383	379	374	370	365	360	354	347
18.5	416	415	415	413	411	409	405	402	398	392	387	383	376	370	363
17.5	438	437	436	434	432	429	425	421	417	412	405	400	393	387	380
16.5	459	459	457	456	452	451	446	442	437	433	427	419	413	406	397
15.5	482	481	480	479	477	473	469	464	458	451	445	438	432	423	415
14.5	507	506	505	502	501	497	493	487	481	474	468	460	452	444	434
13.5	532	532	532	530	526	523	517	513	506	499	491	483	473	465	454
12.5	562	561	560	557	553	550	544	538	531	525	516	506	496	487	475
11.5	592	591	590	587	584	580	574	566	560	552	542	532	521	509	498
10.5	624	623	623	618	615	611	603	598	588	580	570	559	547	534	520
9.5	658	657	657	653	648	644	637	629	620	611	599	587	575	561	547
8.5	695	694	692	689	684	679	672	664	655	643	632	617	604	588	573
7.5	732	731	729	726	722	716	709	699	689	678	664	649	634	617	600
6.5	772	771	769	767	763	757	748	738	727	715	699	684	665	647	628
5.5	813	813	812	808	805	797	789	779	767	752	737	718	699	678	657
4.5	855	856	853	851	845	841	832	821	809	793	773	753	733	709	685
3.5	895	894	894	892	889	885	876	863	849	829	808	788	764	737	714
2.5	930	929	933	928	928	922	920	909	889	867	843	819	791	764	738
1.5	958	960	960	960	963	964	959	946	922	895	868	843	815	785	754
0.5	974	968	967	965	977	985	990	978	943	909	875	852	817	789	750

Figure 3 provides a general view of the distribution fields of magnetic induction in the GPV cross-sectional plane at different positions of the rotors relative to the longitudinal axis of the stator's vacuum channels.

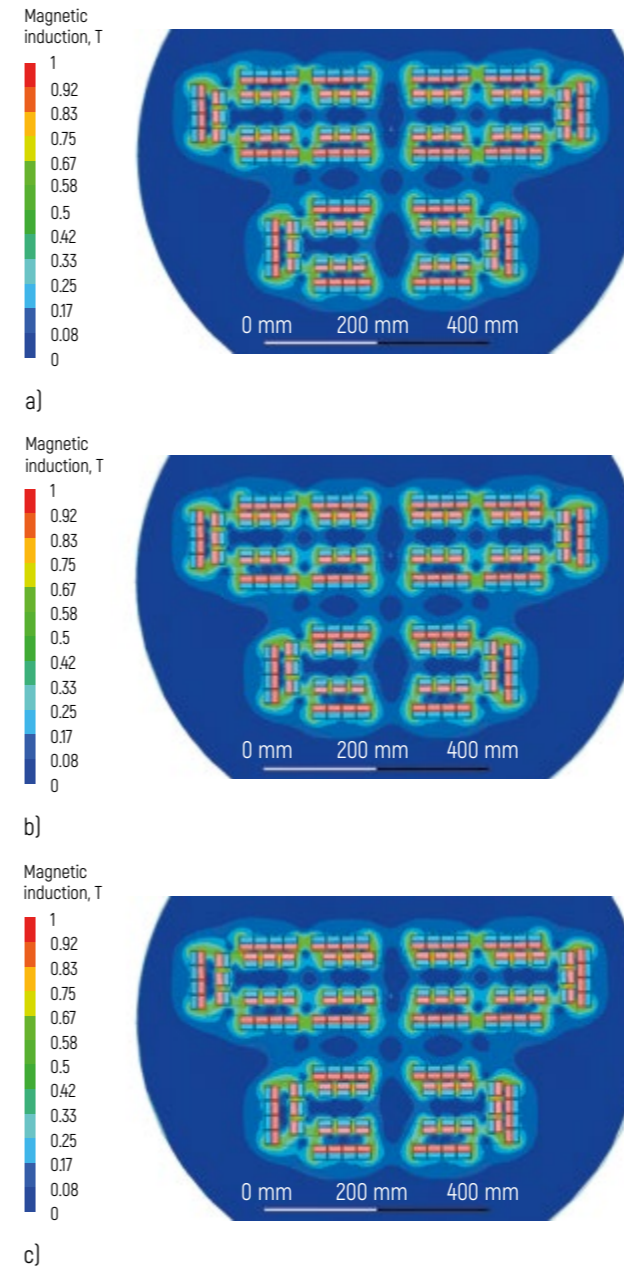

Figure 3 – General view of the distribution fields of magnetic induction in the GPV cross-sectional plane:
a – axes of the rotors coincide with the axes of the stator channels;
b – rotors are shifted vertically to the maximum position;
c – rotors are shifted transversely and vertically to the maximum position

Layout of Power Units in the Design of Linear Rotors and Linear Stators

Taking into account the previously stated requirements for the GPV load capacity and the possibility of increasing its circumferential length by 6.5 % during ascent to the Earth's orbit, as well as calculating the power characteristics of the basic MSSU component, it is possible to determine the required number of power units for vertical and transverse stabilization of the linear rotors and to perform the initial layout of the GPV components.

To stabilize the rotor 1 with a mass of 450 kg/lin m in the vertical direction and rotation relative to the channel axis, eight power units are used; for the transverse direction the number of units is two. For the rotor 2 with a mass of 200 kg/lin m the numbers are four and two units respectively (Figure 4).

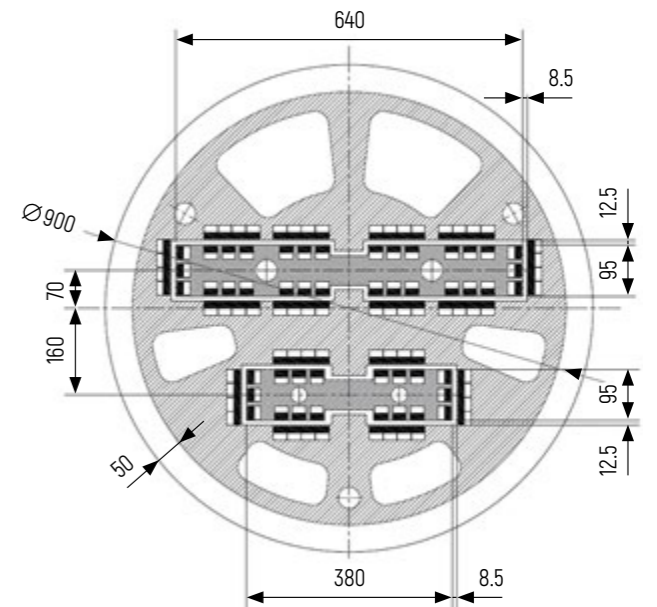

Figure 4 – Cross section of the GPV with the MSSU of linear rotors (option), mm

According to the equation (1), the maximum interaction force occurs between the rotor 1 and the stator in the mode in which the GPV is climbing into the near-Earth orbit. Taking into account the dynamic vibrations of the structural elements, this force is equal to 13.7 kN/lin m. Based on the size of the permanent magnets used and the design of the MSSU power unit, the thickness of one stator segment will be

approximately 110 mm, which is equivalent to about nine segments per the GPV linear meter, or 72 power units (36 pairs) working to accommodate vertical load during climbing. The mutual functioning of a pair of power units (upper and lower), namely the difference in the normal gaps between them in a pair, determines the elastic characteristic of the rotor magnetic suspension. With a relatively even distribution, the maximum load on a single pair of power units would be as follows:

$$Q_{M_{max}} = \frac{q_{M_{max}}}{N_c} = \frac{13,692}{36} = 380 \text{ N}, \quad (2)$$

where N_c is the number of power unit pairs per the GPV linear meter, pcs/lin m.

According to Table 2, if the initial normal gap $Dist_N$ between the magnetic groups is 12.5 mm, and the tangential shift $Dist_T$, considering possible lateral vibrations of the rotors, does not exceed 8 mm, then, when the rotor is displaced by centrifugal force by 1 mm from the zero position, a pair of power units will create a lifting force of 1.9 kN/lin m, when by 2 mm – of 3.6 kN/lin m, when by 4 mm – of 7.9 kN/lin m, when by 8 mm – of 16 kN/lin m, when by 10 mm – of 20.2 kN/lin m, which is enough for the GPV takeoff and its subsequent climbing into the near-Earth orbit. At the same time, there remains a safety gap of at least 4 mm between the rotor and stator wall in nonstationary dynamic modes and about 8 mm in uniformly accelerated motion of the GPV.

To minimize the moment of twisting of the GPV body relative to its axis in ascent/descent modes, the layout should be carried out so that the common center of mass is as close to the center of the cross section as possible, both when loaded and unloaded.

The GPV linear rotors and stator consist of separate segments (Figure 5), which will be standardized. Their pre-assembly and acceptance inspection are also regulated, allowing for parallel production of the GPV components and minimizing construction time and costs.

All segments have a relatively small thickness (up to 110 mm) and weight (no more than 50 kg), which does not require the application of heavy lifting equipment when assembling the GPV with the use of the construction kit method (Figure 6).

Special guide cylinders-dampers, elastic elements and other components are used as connecting elements, which will provide the structure with the ability to extend up to 6.5 % (if necessary, up to 8 % for lifting to a height of up to 500 km) and dampen vibrations during transient acceleration/deceleration of the linear rotors.

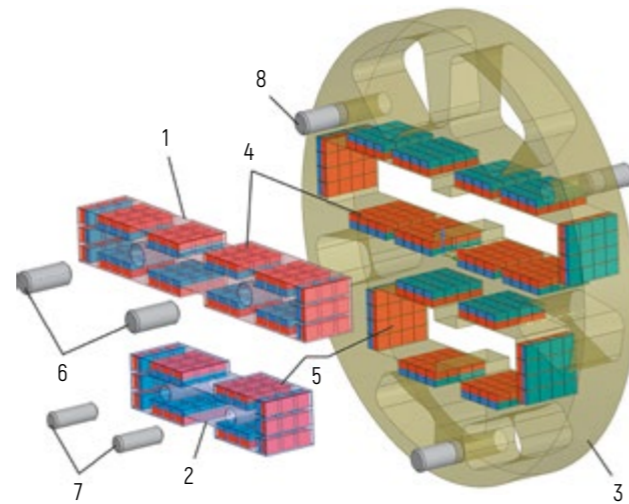

Figure 5 – Assembly of the GPV components: 1 – segment of the rotor 1; 2 – segment of the rotor 2; 3 – segment of the stator; 4 – MSSU of the rotor 1; 5 – MSSU of the rotor 2; 6 – guide components of the rotor 1; 7 – guide components of the rotor 2; 8 – guide components of the stator

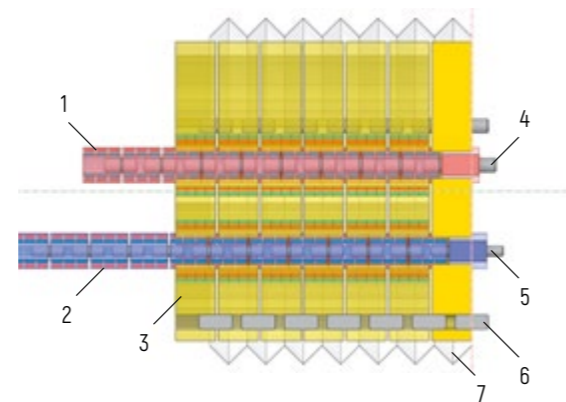

Figure 6 – Longitudinal section of the GPV: 1 – segment of the rotor 1; 2 – segment of the rotor 2; 3 – segment of the stator; 4 – guide components of the rotor 1; 5 – guide components of the rotor 2; 6 – guide components of the stator; 7 – GPV body

Computer Model and Simulation Modeling of the Dynamics of Magnetic System of the GPV Stabilizing Unit

At the initial stage of the GPV design, a computer model is proposed for conducting simulation modeling of the dynamics of the MSSU of linear rotors and evaluating its operability and resistance to external destabilizing influences.

Each power unit as a basic component of the system is represented by only two nodes of the finite element model: the first is the magnetic group of the stator, the second is the magnetic group of the rotor. When calculating the dynamic response of the structure, at each step of integration the normal and tangential components of the magnetic forces will be applied to the nodes, the magnitude of which will be determined by interpolation from known numerical arrays (Tables 1, 2) and the displacement distances of the nodes $Dist_T$ и $Dist_N$ relative to each other at each moment of the estimated time (Figure 7). In this way, magnetic forces will be taken into account in the entire set of power units of the MSSU of linear rotors.

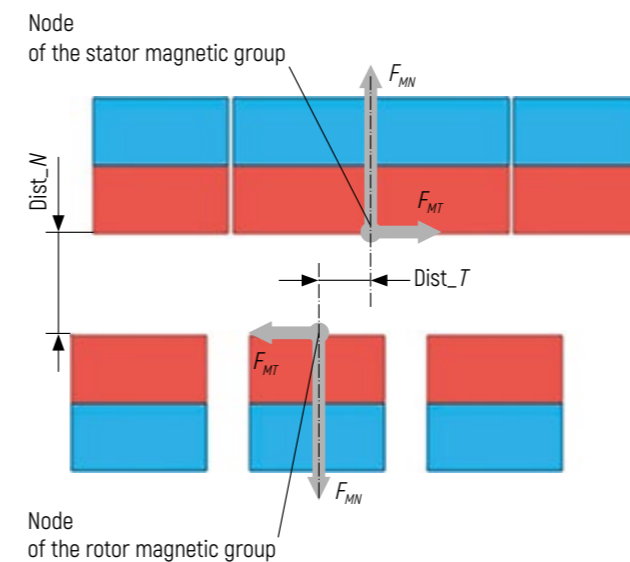

Figure 7 – Consideration of magnetic forces in the calculation model of each power unit of the MSSU

Each segment of the GPV stator and rotors is defined by a single element with known mass-inertia characteristics. The strength of the gravitational interaction of these elements with the planet will depend on the height of the GPV position above ground level and is determined in the model by the acceleration of gravity: from 9.78 m/s² on the Earth's surface at the equator to 8.65 m/s² at an altitude of 415 km above the surface.

The centrifugal (lifting) force, which acts on the rotors' segments and is dependent on their movement speed, mass and radius of orbit, is applied as a concentrated force at the center of mass of each segment of the rotors.

The connection of the corresponding nodes of the power units with the centers of mass of the stator and the rotors at this stage of the simulation is accepted as absolutely rigid. The longitudinal connection of adjacent segments is modeled by an elastic-damping two-node element.

A sinusoidal load (harmonic effect) is used as a destabilizing effect in the form of deflection of the body and/or the linear rotors by different amplitudes in the frequency range of 0.1–10 Hz (wind load, maximum ground movements during earthquakes, effects during fluctuations of oceanic waves, possible rotor imbalances).

Figure 8 shows a fragment from the program code with the initial data for simulation modeling.

INITIAL DATA :	
R0=6371000	!Initial radius of the GPV, m
M=5.97e24	!Mass of Earth, kg
G=6.67e-11	!Gravitational constant, m ³ /(kg × s ²)
H=0	!Initial height above sea level, m
m1=450	!Linear mass of the rotor_1, kg/lin m
Ixx1=10	!Moment of inertia of the rotor_1, kg × m ²
dX1=0	!Initial coordination of the rotor_1, m
dY1=-0.00185	!Initial coordination of the rotor_1, m
m2=200	!Linear mass of the rotor_2, kg/lin m
Ixx2=10	!Moment of inertia of the rotor_2, kg × m ²
dX2=0	!Initial coordination of the rotor_2, m
dY2=-0.00173	!Initial coordination of the rotor_2, m
m3=500	!Linear mass of the stator with a load, kg/lin m
Ixx3=100	!Moment of inertia of the stator with a load, kg × m ²
gapXs1=-3	!Tangential gap of the vertical group of the rotor_1, mm
gapYs1=8.5	!Normal gap of the vertical group of the rotor_1, mm
gapX1=6	!Tangential gap of the transverse group of the rotor_1, mm
gapY1=12.5	!Normal gap of the transverse group of the rotor_1, mm
gapXs2=-2	!Tangential gap of the vertical group of the rotor_2, mm
gapYs2=8.5	!Normal gap of the vertical group of the rotor_2, mm
gapX2=6	!Tangential gap of the transverse group of the rotor_2, mm
gapY2=12.5	!Normal gap of the transverse group of the rotor_2, mm

Figure 8 – Input of initial data in the form of a macro fragment for building a computer model of the GPV MSSU

Figure 9 shows a general view of the calculation model derived from the results of the transformation of the volumetric geometric GPV model. The solver type is dynamic, and the software used is ANSYS APDL Transient. The initial time integration step is 0.001 s (1 ms).

The main advantages of the proposed computational methodology and dynamic model are the need for relatively low computing power as well as a balance between labor costs and the results obtained on the dynamic response of the structure to destabilizing effects.

Concurrently, the conducted research will make it possible to find a workable version of the MSSU of linear rotors and prepare data for the transition to a more complex simulation of the detailed GPV model at the stage of the practical implementation of the project.

Figure 10 illustrates the MSSU operating with a 7 mm vertical and 4 mm horizontal deviation of the rotors from the longitudinal axis of the stator channel. At the same time, the rotors do not rotate and the initial gap between the magnetic groups is 12.5 mm vertically and 8.5 mm horizontally.

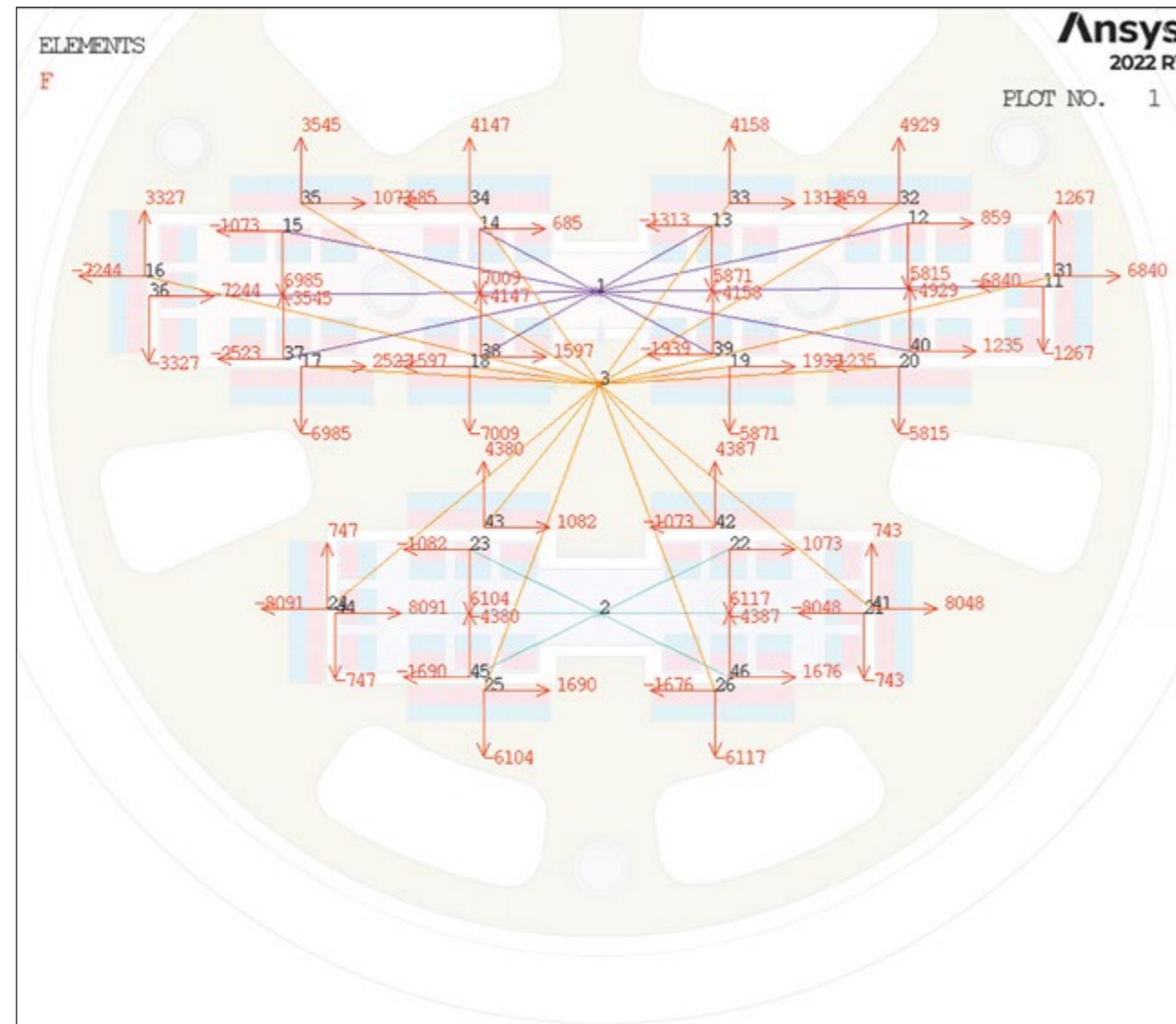

Figure 9 – General view of the calculated dynamic GPV model:
1 – rotor 1; 2 – rotor 2; 3 – stator with housing and payload;
11–46 – magnetic groups of power units

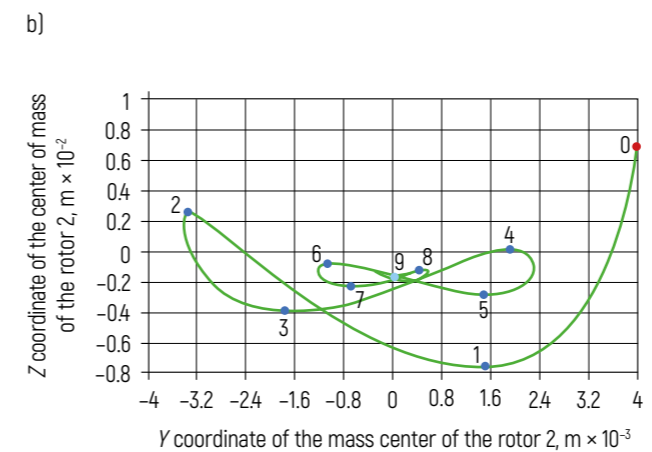
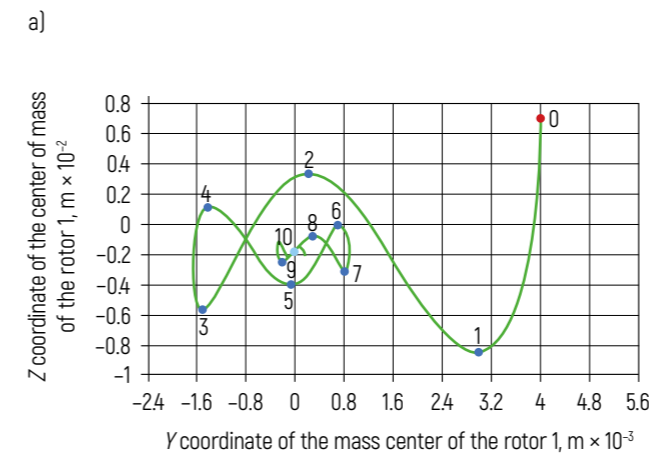
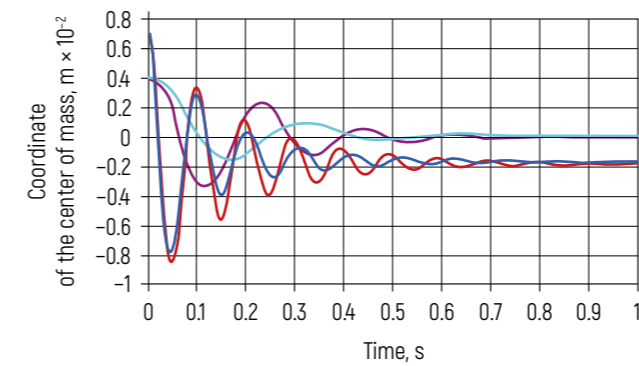

Figure 10 – Operation of the MSSU with destabilizing deviation of the rotors:
a – changes in the transverse and vertical coordinates of the centers of mass of the rotors when stabilized by magnetic forces after deviation from the balanced position;
b – trajectory of the center of mass of the rotor 1 when stabilized by magnetic forces after deviation (point 0) from the balanced position (point 10);
c – trajectory of the center of mass of the rotor 2 when stabilized by magnetic forces after deviation (point 0) from the balanced position (point 9)

As can be seen from the diagrams, after stabilization, the rotors take their equilibrium position with a coordinate of -1.85 mm for rotor 1 and -1.73 mm for rotor 2.

Figures 11, 12 show diagrams of vertical and transverse accelerations of the rotors and the stator with a destabilizing harmonic deviation of the stator with a frequency of 1 Hz and various amplitudes (simulated earthquake, wind load) during the preparation phase for the GPV launch.

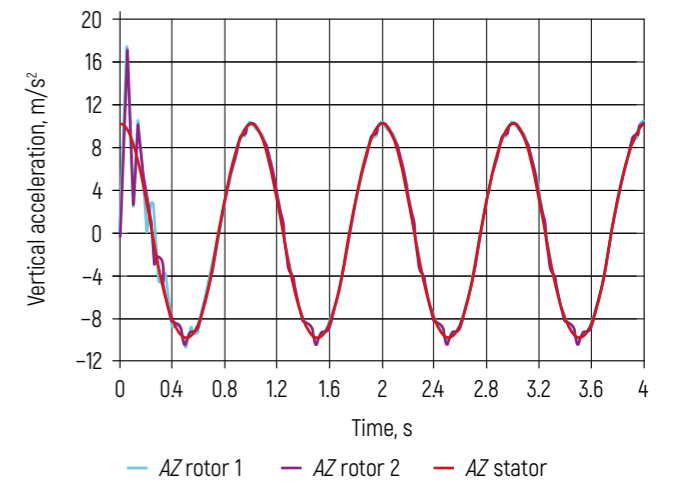

Figure 11 – Vertical accelerations of the centers of mass of the rotors and the stator during the action of a harmonic vertical disturbance with an amplitude of 250 mm and a frequency of 1 Hz

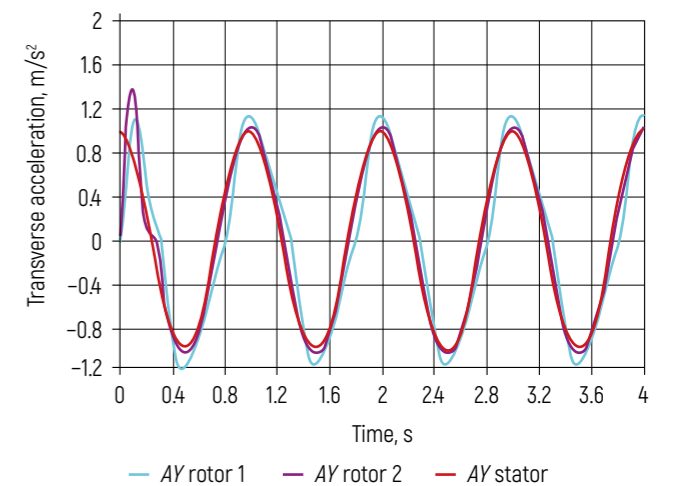
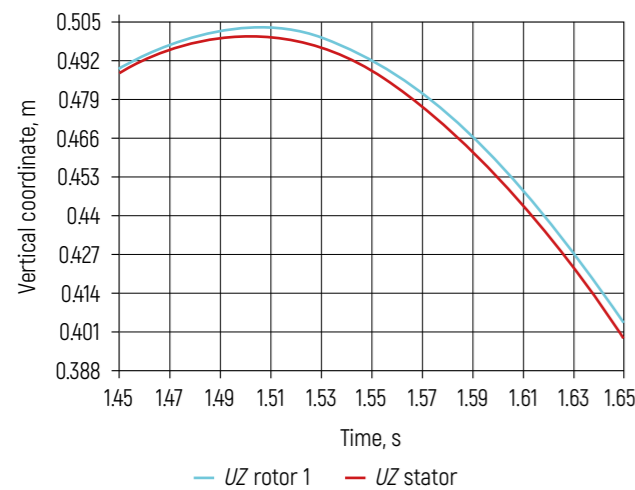
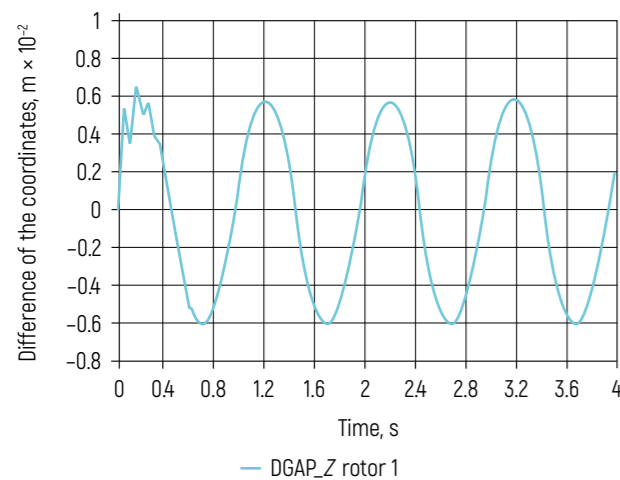

Figure 12 – Transverse accelerations of the centers of mass of the rotors and the stator during the action of a harmonic transverse disturbance with an amplitude of 25 mm and a frequency of 1 Hz

The results of simulation modeling of the dynamic response of the rotors and the stator under different variants of destabilizing effects indicate the possibility of implementing a permanent magnet-based MSSU and good performance of the proposed design option capable of ensuring safe operation of the GPV with a vertical inertial load of up to 12 m/s^2 (in the direction of gravity) and a transverse load of up to 1.2 m/s^2 . Figures 13 and 14 show the change in the gap



a)



b)

Figure 13 – Changes in the linear coordinates of the centers of mass of the rotor 1 and the stator during the action of a harmonic vertical disturbance with an amplitude of 250 mm and a frequency of 1 Hz: a – absolute change in the vertical coordinate; b – relative difference in the vertical coordinates of the stator and the rotor 1

between the magnetic groups of the MSSU power units under such perturbations.

The diagram 14b shows the following: the rotor 1, due to its greater mass compared to the rotor 2, is subject to much greater transverse deviations, which limits the maximum inertial loads in this direction for the GPV. As a recommendation, it is proposed to work out a design with additional power units in the transverse direction for the rotor 1.

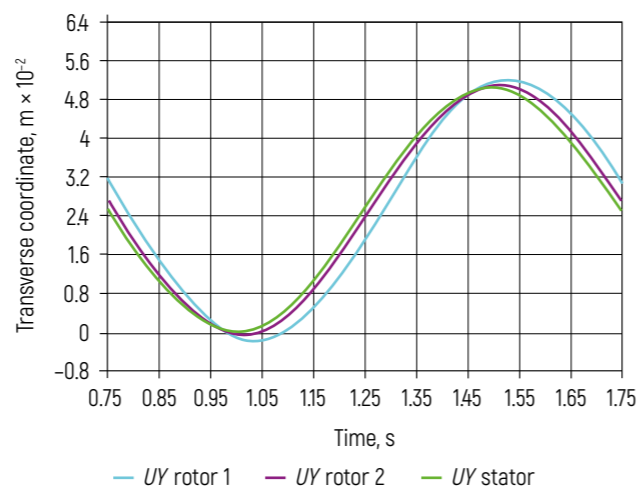

a)

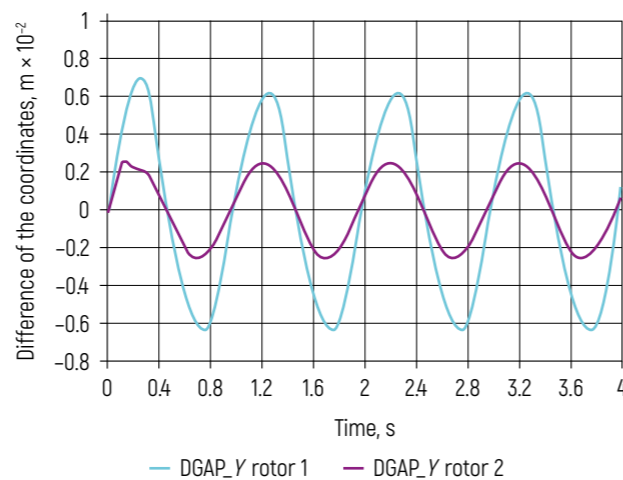

b)

Figure 14 – Changes in the linear coordinates of the centers of mass of the rotors and the stator during the action of a harmonic transverse disturbance with an amplitude of 25 mm and a frequency of 1 Hz: a – absolute change in the vertical coordinate; b – relative difference in the vertical coordinates of the stator and the rotors

Conclusion

In this article the key technical requirements and approaches for the design of a linear rotors stabilization system in vacuum channels of the linear stators are presented. We propose the implementation of such a system using permanent magnets, which will ensure minimal energy consumption and a high level of safety for the GPV as the main element of the project of non-rocket near space exploration.

A calculation technique and a computer model have been developed, thanks to which it is possible to evaluate the dynamics and stability of the MSSU of linear rotors to external destabilizing loads, in particular, a harmonic force disturbance affecting the body and/or the rotors of the GPV.

The use of advanced digital calculation methods and specialized software enables, at the design phase of the magnetic rotor stabilization system, to assess its operability, efficiency and safety at all stages of operation. The next stage of research and modeling involves an experimental verification of the characteristics of the proposed power unit design, followed by a validation of the calculation and testing results, as well as improvement of the calculation methods and computer models used to find optimal solutions for the implementation of a magnetic stabilization system for the linear rotors in the GPV structure.

References

1. Unitsky, A. *String Transport Systems: On Earth and in Space* / A. Unitsky. – Silakrogs: PNB Print, 2019. – 576 p.
2. Unitsky, A. *SpaceWay Program as the Only Possible Scenario to Save the Earthly Technocratic Civilization from Extinction and Death* / A. Unitsky // *Non-Rocket Space Industrialization: Problems, Ideas, Projects: Collection of Articles of the II International Scientific and Technical Conference, Maryina Gorka, Jun. 21, 2019* / Astroengineering Technologies LLC; ed. A. Unitsky. – Minsk: Paradox, 2019. – P. 31–39.
3. Unitsky, A. *Magnetic System of Power Stabilizing Unit of the General Planetary Vehicle* / A. Unitsky, V. Looksha // *Non-Rocket Near Space Industrialization: Problems, Ideas, Projects: Collection of Articles of the V International Scientific and Technical Conference, Maryina Gorka, Sep. 23–24, 2022* / Astroengineering Technologies LLC, Unitsky String Technologies Inc., ed. A. Unitsky. – Minsk: StroyMediaProject, 2023. – P. 56–63.

4. Martynenko, Yu.G. *O problemakh levitatsii tel v silovykh polyakh [On the Problems of Levitation of Bodies in Force Fields]* / Yu.G. Martynenko // *Sorosovskiy obrazovatel'nyy zhurnal*. – 1996. – No. 3. – P. 82–86.
5. Unitsky, A.E. *Sozdaniye matematicheskoy modeli obshcheplanetarnogo transportnogo sredstva s optimizatsiyey polozheniya i uchotom vliyaniya dinamicheskikh faktorov [Creation of a Mathematical Model of the General Planetary Vehicle with Optimization Position and Taking into Account the Influence of Dynamic Factors]* / A.E. Unitsky, R.A. Sharshov, A.A. Abakumov // *Bezraketnaya industrializatsiya blizhnego kosmosa: problemy, idei, projekty: Collection of Articles of the III International Scientific and Technical Conference, Maryina Gorka, Sep. 12, 2020* / Astroengineering Technologies LLC, Unitsky String Technologies Inc.; ed. A.E. Unitsky. – Minsk: StroyMediaProyekt, 2021. – P. 182–193.
6. Unitsky, A. *Creating a Mathematical Model of the General Planetary Vehicle Accelerating Flywheels, Passing the Atmosphere, Going into Orbit* / A. Unitsky, R. Sharshov, A. Abakumov // *Non-Rocket Space Industrialization: Problems, Ideas, Projects: Collection of Articles of the II International Scientific and Technical Conference, Maryina Gorka, Jun. 21, 2019* / Astroengineering Technologies LLC; ed. A. Unitsky. – Minsk: Paradox, 2019. – P. 77–83.
7. Bashyam, A. *Design and Experimental Validation of Unilateral Linear Halbach Magnet Arrays for Single-Sided Magnetic Resonance* / A. Bashyam, M. Li, M.J. Cima // *Journal of Magnetic Resonance*. – 2018. – Vol. 292. – P. 36–43.
8. *Rare Earth Elements Aren't the Secret Weapon China Thinks They Are* [Electronic resource]. – Mode of access: <https://www.theverge.com/2019/5/23/18637071/rare-earth-china-production-america-demand-trade-wartariffs>. – Date of access: 06.05.2023.
9. *Obshchaya fizika: elektrichestvo i magnetizm [General Physics: Electricity and Magnetism]* / A.K. Yesman [et al.]. – Minsk: BNTU, 2017. – 300 p.

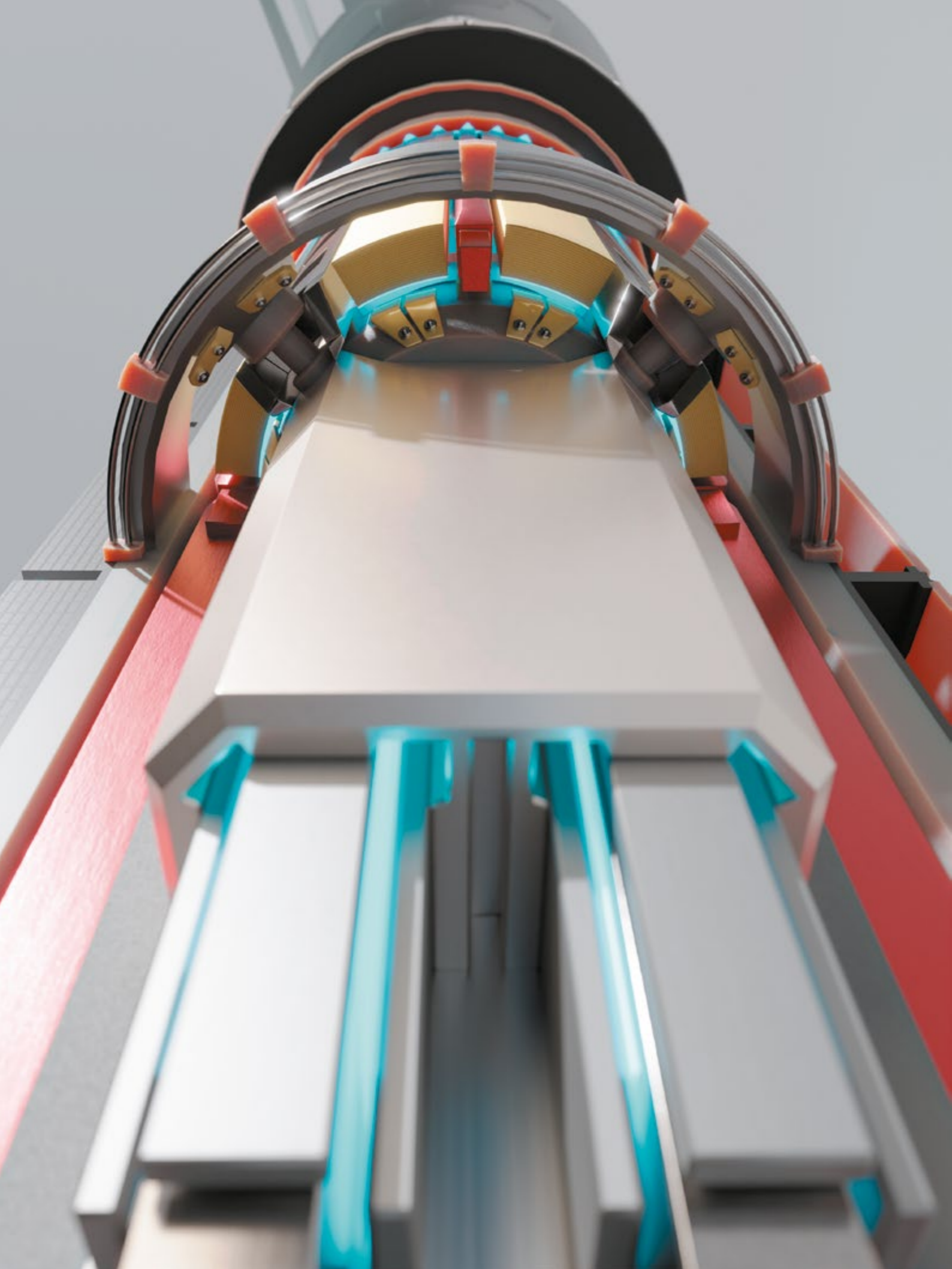

UDC 53.098

Providing Levitation of the General Planetary Vehicle Rotor Using Permanent Magnets

A. Unitsky^{1,2}
Dr. of Philosophy
in Information Technologies
(Transport)

S. Artyushevsky²

V. Looksha²

¹ Astroengineering Technologies LLC,
Minsk, Belarus

² Unitsky String Technologies Inc.,
Minsk, Belarus



The efficiency factor of the rotor propulsion unit of the General Planetary Vehicle (GPV) should asymptotically approach 100 %. To fulfill this condition, the authors of the work have chosen a magnetic system as the most energy-efficient one consisting of two subsystems: forceful rotor holding in the desired position (on permanent magnets) and stabilization (based on electromagnets). The permanent magnet subsystem takes on the entire load, and only in transient modes a part of the load falls on the electromagnets. Previous experimental models have significant disadvantages: inoperability at low speeds, high resistance to axial movement of the rotor, the presence of unacceptable natural vibrations and heating of the rotor. As a consequence, the efficiency factor of the propulsion unit as a whole is insufficient. The article presents a design solution that is devoid of the mentioned disadvantages, ensuring levitation of the magnetic rotor and at the same time not interfering with its free axial movement. To organize uniform movement without losses from edge effects, it is proposed to use magnets of special shapes and sizes.

Keywords:

General Planetary Vehicle (GPV), magnetic levitation, permanent magnets, vaulted magnets.

Introduction

The history of the transport industry development clearly shows its importance in the social, economic and military formation of society and our technogenic civilization [1]. It is the transport that can play a key role in the spatial separation of the technosphere and biosphere, relocating hazardous and harmful industries to near space. This idea was put forward by K. Tsiolkovsky, and the solution of its implementation was found by inventor and engineer A. Unitsky [2], who developed the design of the General Planetary Vehicle (GPV) – a geocosmic aircraft with a length of more than 40,000 km. This self-supporting system, which functions only due to internal forces, is capable of transferring up to 10 mln tons of payload to near-Earth space and back during one ascent.

Modern rockets have a high level of energy consumption (total energy efficiency factor is less than 1%) and a low payload capacity (up to 100 tons) [2]. These two key factors make the cost of geocosmic transportation using launch vehicles extremely high and, consequently, restrain the industrialization of space.

The core source of energy consumption in the GPV is the "engine – suspension" system, a set of structural elements that suspends, maintains and accelerates linear flywheels to cosmic velocities. This is one of the main parts of the GPV; increasing its efficiency factor is a key task, the solution of which will lead to a reduction in the curb weight of the vehicle, improve the reliability of the system as a whole and minimize energy consumption.

It is necessary to start with minimization of energy consumption for noncontact maintenance of linear rotors in a suspended state relatively to the walls of vacuum channels. This requires the development of a magnetic levitation system and stabilization of the rotors that will allow to reach a speed of 12 km/s without axial resistance, which is needed for lifting the GPV with a weight of about 40 mln tons into near space – into a circular equatorial orbit [3].

Statement of Problem

Magnetic levitation is a method of suspending an object (body) by means of a magnetic field. It is used to compensate for gravity, gravitational acceleration, centrifugal or any other forces.

The magnetic field in suspensions is created by permanent magnets, the main advantages of which are considered to be energy independence and stable characteristics over

a long period of operation. The suspended body must be partially or completely made of ferromagnetic materials and capable of carrying permanent magnets. The object is suspended due to forces of repulsion and/or attraction.

The magnetic suspension is an eco-friendly system that reduces noise, vibration and wear caused by friction and does not pollute the environment. As for levitation, one of the most popular methods is the electromagnetic suspension. However, this system has problems with power consumption and heating, as a direct current must be supplied to maintain the desired air gap.

Permanent magnets (PMs) are applied along with electromagnets (EMs) to reduce power consumption. The total weight levitates due to PMs, while EMs is used to eliminate external interference and weight fluctuations. Power is mainly consumed during the transient period, and the temperature rise of the coil can be minimized. Another advantage of such hybrid systems is the reduction of additional electronic components due to low power EMs.

The use of PMs for levitation, lateral stabilization and linear displacement removes the necessity of constant monitoring and simplifies control systems, reduces the risk of failures during operation, increases the efficiency and reliability of the system. Such suspension becomes energy-independent and does not need additional power supply from the external network. Since magnetic fields are dissipated yet at short distances, the need for passive and/or active magnetic shields is excluded. At the same time, the possibility of using large gaps between the moving elements lowers the requirements for manufacturing accuracy and surface quality of the track structure and rotor. As a result, there is a significant reduction of capital and operating costs (according to preliminary calculations of the authors, by 3–4 times in comparison with traditional technologies), service maintenance of PMs systems is practically excluded due to their high reliability and long service life of magnets.

According to Earnshaw's theorem (1842), a stable equilibrium is impossible in a system of bodies interacting through fields whose potential varies inversely proportional to the distance from the source and which are not capable of isotropic eviction of interaction fields from the occupied space. This imposes a number of limitations and requires new conceptual solutions of the suspension design, considering all available forces in the system and consistent elimination and/or compensation of their interaction impact. The fields, the potential of which decreases inversely proportional to the squares of distances from the sources,

in our case include gravitational, magnetic and electrostatic ones [4]. To obtain a stable equilibrium in such fields, a system with the missing potential energy at the equilibrium point is required.

In the currently existing PMs-based levitation systems, equilibrium is not possible in the direction of one of the freedom degrees. Therefore, it is necessary to provide both levitation and lateral stabilization.

Consequently, the PMs-based suspension system to be created should have a maximum working force in the radial direction (centrifugal force direction) and a minimum tangential force from lateral end displacement relatively to each other in the "excluded" equilibrium direction.

Development of the PMs Application Concept

The PMs-based levitation system being developed is designed to maintain and move in a suspended noncontact position of the GPV circular rotor with a weight of 250 kg/lin m at a speed of up to 12 km/s.

The purpose of creating a model installation is to experimentally confirm the possibility of obtaining dynamic levitation and rotor stabilization with the absence of edge effects. The objective tasks to achieve the goal are as follows:

- to develop a concept of PMs application, assuming the use of vaulted magnets in combination with the obtained scheme of direction of fields and forces as well as the absence of magnetic wells and attraction forces between the vacuum track structure and the rotor;
- to create an experimental installation, using vaulted PMs in combination with the developed scheme of direction of fields and forces;
- to achieve linear displacement of the rotor, at which there are no magnetic wells and attraction force between the track structure and the rotor, to carry out measurements of vertical and lateral forces.

Use of Specially Shaped Magnets

The magnetic field of PMs depends on the shape of the magnet and appears as concentric circles (Figure 1). When the magnets are arranged sequentially, the fields are redistributed but also have a spherical-elliptical shape. The magnetic poles are oriented in space in such a way that the magnetic induction in the working gap meets the technical requirements.

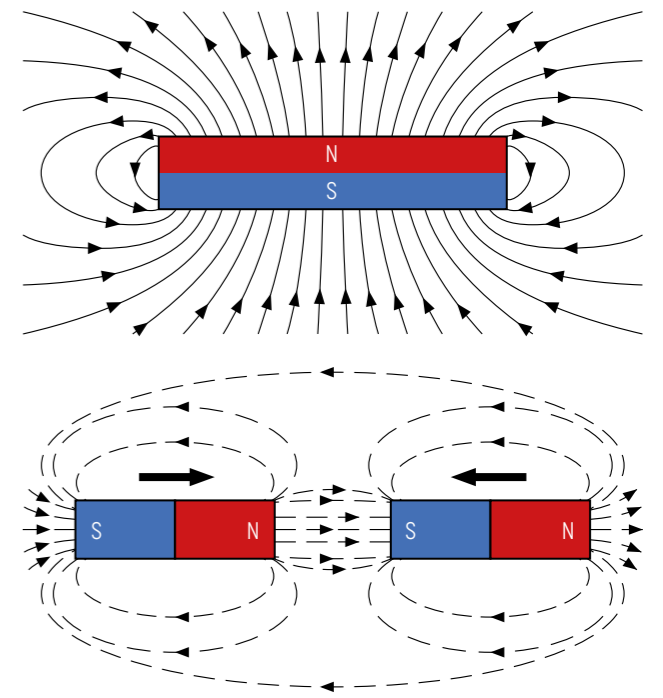

Figure 1 – Shape of fields of a single and sequentially arranged magnets

Taking into account that the magnetic field is a contact sliding surface and forms the trajectory of the rotor motion (with wells and ridges), the wavy surface of dense magnetic fields lengthens the traveled path, includes gravitational and inertial force as well as provokes galloping and vibrating of the system. It should be noted that even with a single-pole arrangement of magnets, the interaction (attraction) of opposite poles occurs when the edge of the moving and stationary magnet coincide. The edge effect appears, which in synergy with the magnetic well, reducing the gap and thus increasing the attraction, creates additional resistance and imbalance of the system. In order to exclude the edge effect revealed in preliminary calculations, the use of special vaulted shape magnets was proposed (Figure 2).



Figure 2 – Vaulted magnet

The advantage of this type of magnets is to separate the edge from the opposite pole by a distance sufficient to remove the forces of attraction.

The interaction forces of the levitating suspension system based on vaulted PMs were calculated.

Statement of the problem: to calculate the force interaction and draw up a map of the distribution of magnetic induction lines in the PMs system.

As a basic model of the suspension, a layout with fixed magnets (stator) and moving magnets (rotor) of the same shape and size with the following characteristics was adopted:

- material $Nd_2Fe_{14}B$;
- material brand N40;
- magnetic induction of 1.26 T;
- coercive force of 955 kA/m.

There occurs a uniform displacement of the rotor relatively to the stator with a speed of 0.1 m/s; airless environment, 0 Pa pressure, 22 °C temperature are noted.

The rotor magnets are mathematically grouped into a single rigid structure – the rotor; the stator magnets are also united into a single structure – the stator (this eliminates mutual movement within the structure). Further, the force with which the stator acts on the rotor was calculated. The dependence graph of this force on the movement of the rotor relatively to the stator was drawn. The calculation model is shown in Figure 3. The upper pair of magnets moves relatively to the lower ones in the direction indicated by the arrow. Modeling and calculation of force interactions of magnetic structures were performed using ANSYS 2022 R1 software.

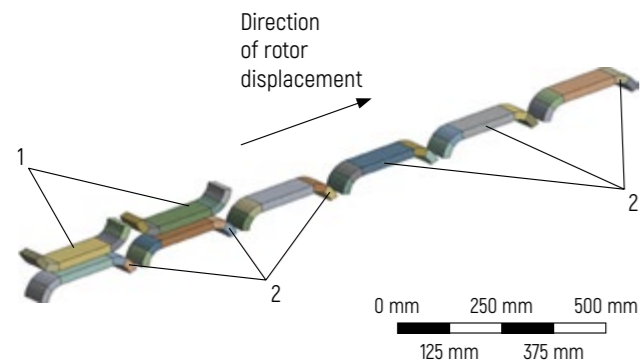

Figure 3 – Calculation model:
1 – rotor magnets;
2 – stator magnets

Boundary conditions of calculation: N40 magnet material, Earth's gravity, "rotor – stator" gap, magnets geometry, nature of relocation of the rotor relatively to the stator.

The results of calculations are presented in the form of magnetic fields and magnetic flux distribution diagrams (Figures 4, 5) and dependence graph (Figure 6).

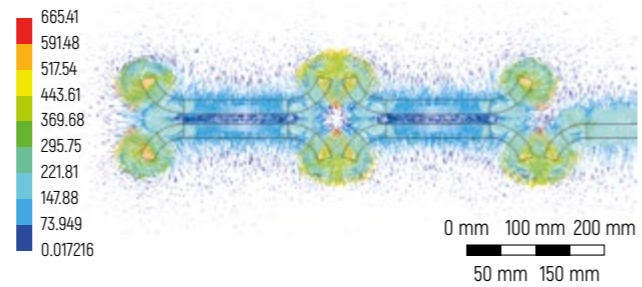

Figure 4 – Magnetic flux distribution in the initial position, mT

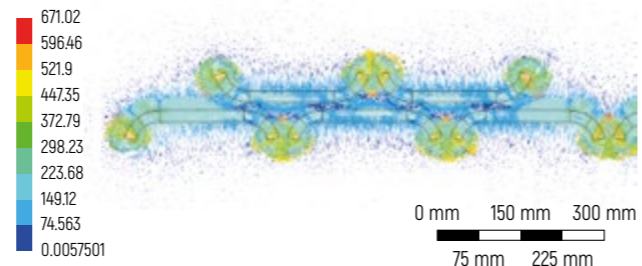

Figure 5 – Magnetic flux distribution at longitudinal displacement of rotor magnets relatively to stator magnets by 160 mm, mT

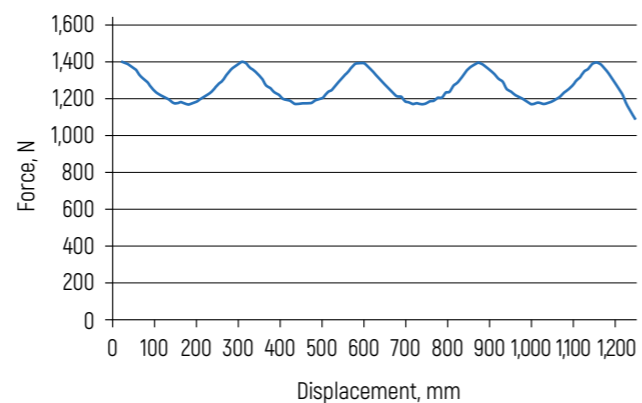

Figure 6 – Dependence graph of force interaction between the resulting vector sums of the stator and rotor magnet fields on their mutual displacement

The computational model contains identical magnets with a length of 300 mm, a width of 70 mm, a thickness of 20 mm and having a radius rounding of 38 mm (Figure 2).

First, the vector sum of all magnetic forces belonging to the rotor was found. Then, the vector sum of all magnetic forces belonging to the stator was determined (Figure 3). As a result, two forces are established: one acts on the rotor from the stator side, the other acts on the stator from the rotor side. Further, the rotor moves with a pitch of 5 mm relatively to the stator. The interaction of the found forces was calculated at each pitch.

Based on the obtained data, the dependence graph of the repulsive force between the rotor and stator on the amount of displacement of the rotor relatively to the stator has been drawn (Figure 6). The magnets of the rotor and stator are facing each other with the same poles. The graph shows wavelike oscillations with a pitch of 300 mm, which corresponds to the length of the rotor/stator magnets. At the same time, the dip zones coincide with the location of the rotor magnets centers over the stator magnets joints. To remove this effect, it is proposed to use elongated permanent rotor magnets, which will allow the PMs magnetic field of the rotor to constantly rest on several ridges of the PMs magnetic fields of the stator and pass over the magnetic wells without falling through.

Further, the force interaction was calculated and a map of the magnetic induction lines distribution in the PMs system was drawn; vaulted magnets of different length were used. The layout was adopted as before: with fixed magnets (stator) and movable magnets (rotor) of the same shape but different sizes. The characteristics and conditions of the calculation have not changed.

There occurs a uniform displacement of the rotor relatively to the stator with a speed of 0.1 m/s; airless environment, 0 Pa pressure, 22 °C temperature are noted. The upper row of magnets moves relatively to the lower one.

On the base of the calculation the graph of the force interaction dependence of two arrays of magnets at different linear dimensions of the array components was plotted. The dimensions of the rotor magnets are 500 × 70 mm, 575 × 70 mm and 650 × 70 mm; the stator magnets are 275 × 70 mm.

The computational models are shown in Figures 7, 10, 13. The calculation results are presented in the form of magnetic flux distribution diagrams (Figures 8, 11, 14) and dependence graphs (Figures 9, 12, 15). The dependence of the specific force of mutual repulsion on the displacement of the rotor relatively to the stator is shown in Table 1.

The dependence graphs of the specific force of interaction between the stator and rotor on their mutual displacement at different lengths of rotor magnets are shown in Figures 16–18.

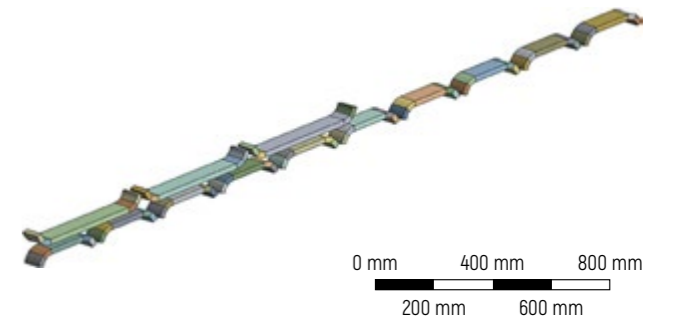

Figure 7 – Calculation model with rotor magnets length of 500 mm (first calculation case)

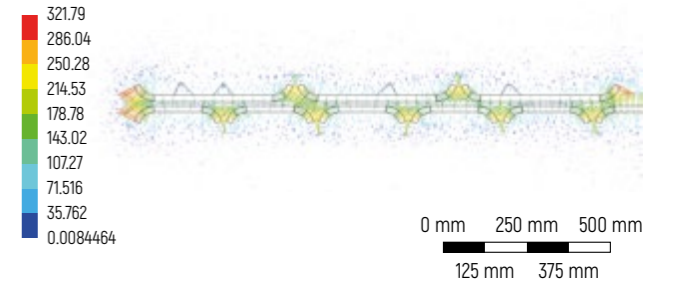

Figure 8 – Magnetic flux distribution in the initial position at rotor magnets length of 500 mm, mT

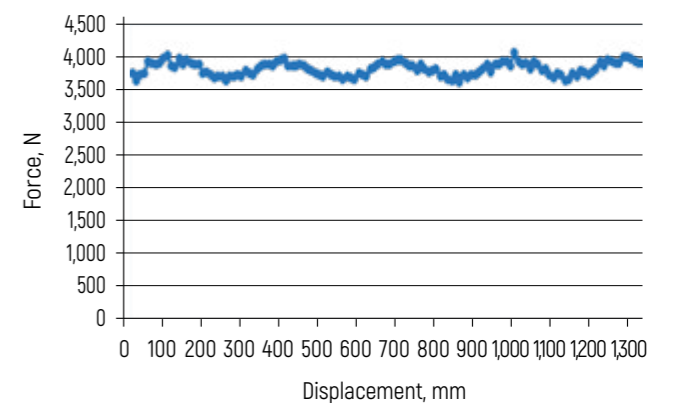

Figure 9 – Dependence graph of force interaction between stator and rotor on their mutual displacement at rotor magnets length of 500 mm

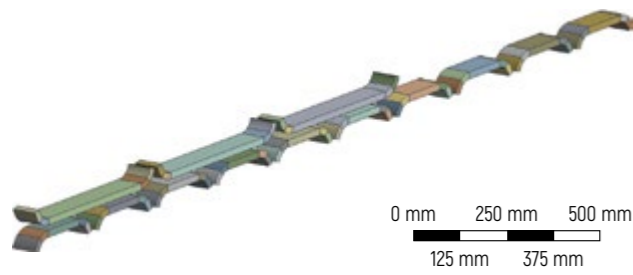

Figure 10 – Calculation model with rotor magnets length of 575 mm [second calculation case]

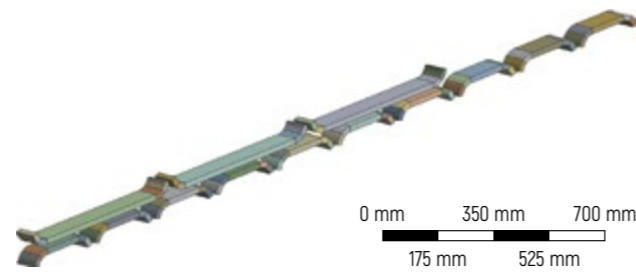

Figure 13 – Calculation model with rotor magnets length of 650 mm [third calculation case]

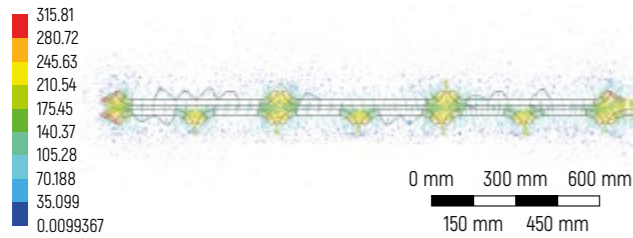

Figure 11 – Magnetic flux distribution in the initial position at rotor magnets length of 575 mm, mT

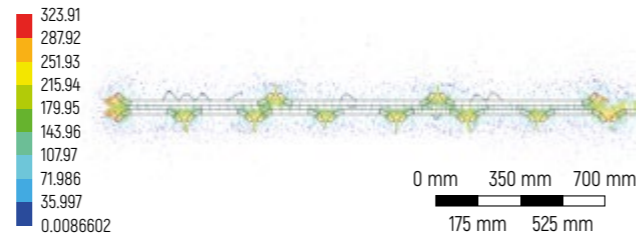

Figure 14 – Magnetic flux distribution in the initial position at rotor magnets length of 650 mm, mT

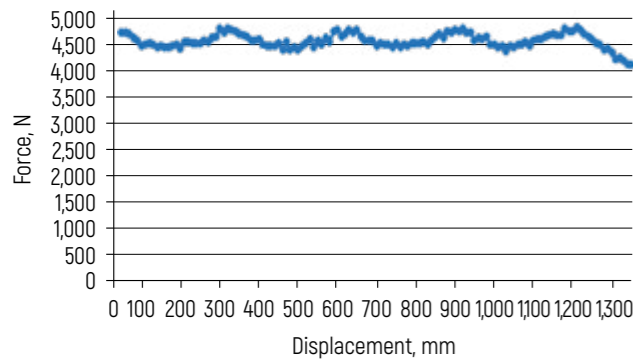

Figure 12 – Dependence graph of force interaction between stator and rotor on their mutual displacement at rotor magnets length of 575 mm

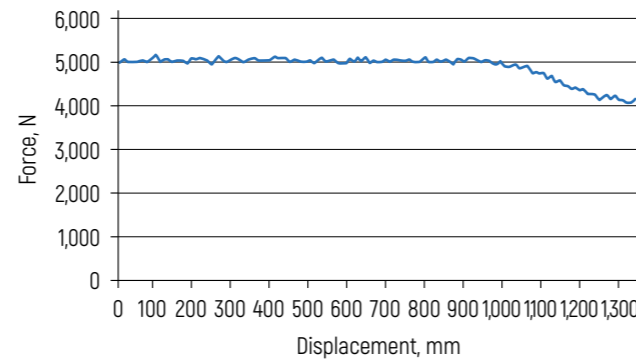

Figure 15 – Dependence graph of force interaction between stator and rotor on their mutual displacement at rotor magnets length of 650 mm

Table 1 – Dependence of the specific force of mutual repulsion on the displacement of the rotor relatively to the stator

Displacement, mm	Length of rotor magnets, mm								
	500			575			650		
	Specific force, N/m ²	Δ , N/m ²	Δ , %	Specific force, N/m ²	Δ , N/m ²	Δ , %	Specific force, N/m ²	Δ , N/m ²	Δ , %
1	2	3	4	5	6	7	8	9	10
50	47,552	-	-	47,757	-	-	45,419	-	-
150	48,897	1,345	2.8	45,182	-2,575	-5.4	45,866	447	1

End of Table 1

	1	2	3	4	5	6	7	8	9	10
200	49,602	2,050	4.3	45,278	-2,479	-5.2	45,521	102	0.2	
250	47,263	-289	-0.6	44,537	-3,220	-6.7	45,821	402	0.9	
300	46,846	-706	-1.5	45,728	-2,029	-4.2	46,383	964	2.1	
350	47,438	-114	-0.2	48,572	815	1.7	46,718	1,299	2.9	
400	49,211	1,659	3.5	47,405	-352	-0.7	45,893	474	1	
450	49,017	1,465	3.1	46,417	-1,340	-2.8	45,680	261	0.6	
500	48,429	877	1.8	45,539	-2,218	-4.6	46,228	809	1.8	
550	47,887	335	0.7	44,440	-3,317	-6.9	45,869	450	1	
600	47,021	-531	-1.1	46,271	-1,486	-3.1	45,964	545	1.2	
650	46,892	-660	-1.4	48,122	365	0.8	45,281	-138	-0.3	
700	49,205	1,653	3.5	48,201	444	0.9	46,420	1,001	2.2	
750	49,516	1,964	4.1	45,164	-2,593	-5.4	45,569	150	0.3	
800	48,369	817	1.7	45,621	-2,136	-4.5	45,962	543	1.2	
850	47,295	-257	-0.5	45,714	-2,043	-4.3	45,530	111	0.2	
900	47,038	-514	-1.1	47,073	-684	-1.4	45,992	573	1.3	
950	48,273	721	1.5	48,170	413	0.9	46,020	601	1.3	
1,000	47,038	-514	-1.1	47,073	-684	-1.4	45,992	573	1.3	
1,050	49,314	1,762	3.7	45,502	-2,255	-4.7	45,046	-373	-0.8	
1,100	47,988	436	0.9	45,011	-2,746	-5.7	44,886	-533	-1.2	
1,150	47,135	-417	-0.9	46,275	-1,482	-3.1	43,478	-1,941	-4.3	
1,200	47,922	370	0.8	47,449	-308	-0.6	41,299	-4,120	-9.1	
1,250	49,672	2,120	4.5	48,105	348	0.7	40,233	-5,186	-11.4	
1,300	49,558	2,006	4.2	46,512	-1,245	-2.6	38,786	-6,633	-14.6	

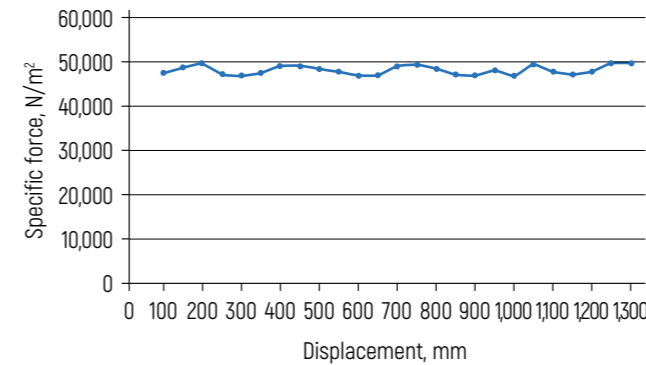

Figure 16 – Dependence graph of the specific interaction force between stator and rotor on their mutual displacement at rotor magnets length of 500 mm

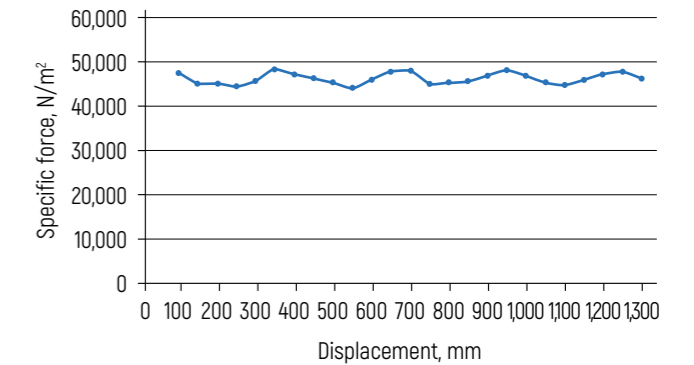

Figure 17 – Dependence graph of the specific interaction force between stator and rotor on their mutual displacement at rotor magnets length of 575 mm

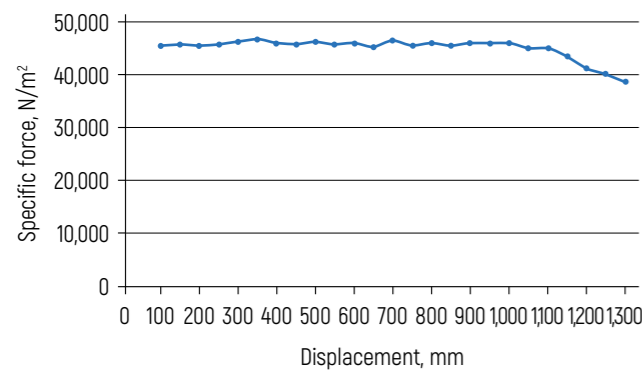

Figure 18 – Dependence graph of the specific interaction force between stator and rotor on their mutual displacement at rotor magnets length of 650 mm

For the third calculation case, the results after a displacement of 1,000 mm were not taken into account, because the rotor went beyond the boundary of the stator magnets (Figure 18).

A layout with fixed magnets (stator) of $50 \times 70 \times 20$ mm size and movable magnets (rotor) of $525 \times 70 \times 20$ mm size is adopted as an alternative PMs suspension model (Figure 19). Characteristics of the stator and rotor magnets:

- material $Nd_2Fe_{14}B$;
- material brand N40;
- magnetic induction of 1.26 T;
- coercive force of 955 kA/m.

There occurs a uniform displacement of the rotor relatively to the stator with a speed of 0.1 m/s; airless environment, 0 Pa pressure, 22 °C temperature are noted.

The force with which the stator acts on the rotor has been calculated. Its dependence graph on the displacement of the rotor relatively to the stator was drawn. Modeling and calculation of force interactions of magnetic structures were performed using ANSYS 2022 R1 software.

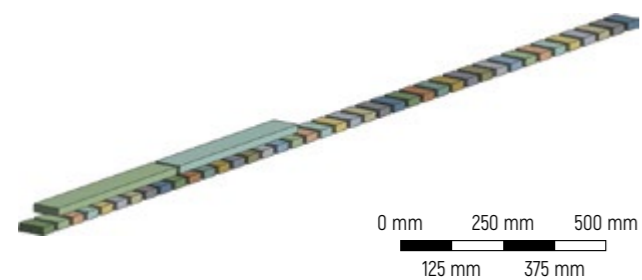

Figure 19 – Computational model

Boundary conditions of calculation: N40 magnet material, Earth gravity, rotor – stator gap, magnets geometry, nature of displacement of the rotor relatively to the stator. The calculation results are presented in the form of 3D diagrams of force vectors and magnetic fields (Figures 20, 21), dependence graphs (Figures 22, 23) and in Table 2.

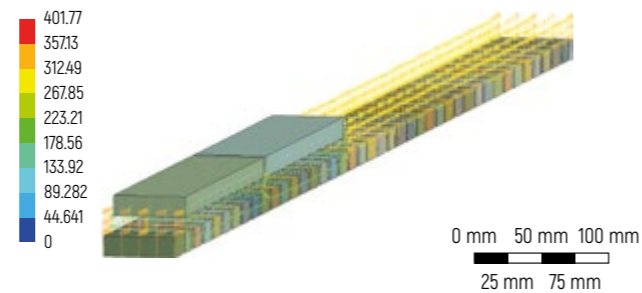

Figure 20 – 3D diagram of the force vectors arising at the interaction of flat neodymium magnets, mT

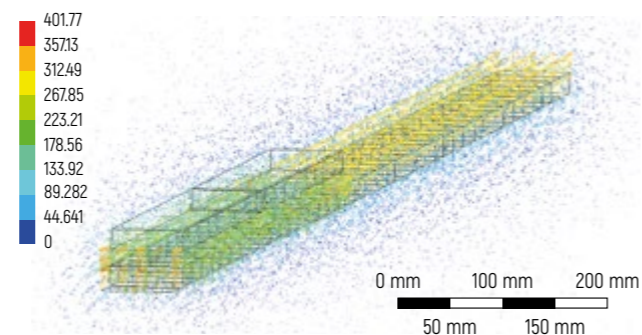

Figure 21 – 3D diagram of the magnetic fields arising at the interaction of flat neodymium magnets, mT

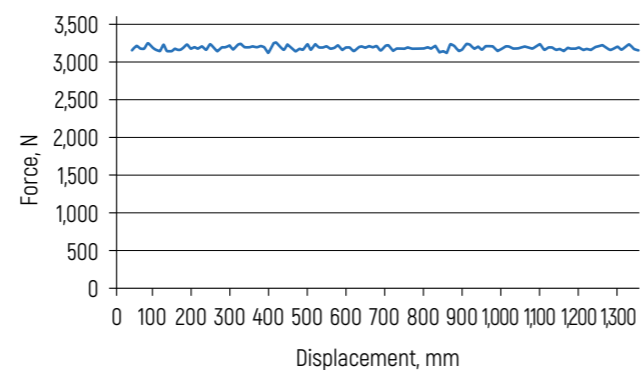

Figure 22 – Dependence graph of the force interaction between the resulting vector sums of the stator and rotor magnet fields from their mutual displacement

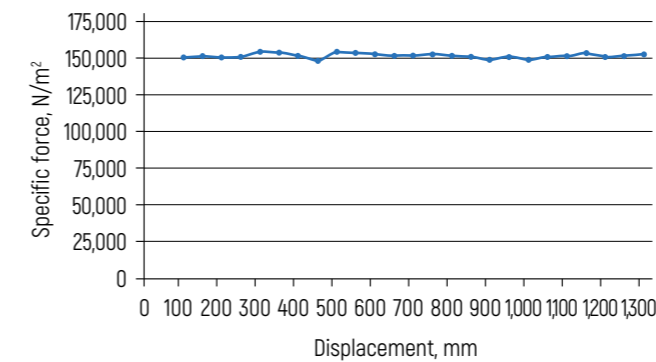

Figure 23 – Dependence graph of the specific interaction force between stator and rotor on their mutual displacement at dimensions of rotor magnets of $525 \times 70 \times 20$ mm, stator of $50 \times 70 \times 20$ mm (rotor magnets total area of 0.021 m^2)

Table 2 – Dependence of the specific interaction force between rotor and stator magnets on their mutual displacement

Displacement, mm	Specific force, N/m ²
50	150,429
150	151,859
200	150,140
250	151,501
300	154,518
350	153,901
400	151,829
450	148,340
500	154,467
550	154,106
600	152,844
650	152,239
700	151,792
750	153,266
800	151,652
850	151,230
900	149,796
950	151,577
1,000	149,796
1,050	151,315
1,100	152,150
1,150	154,052
1,200	151,451
1,250	152,286
1,300	152,994

Analysis of Alternative Options

Figure 20, showing the vectors of forces arising from the plane magnets interaction, traces the parasitic forces of magnets attraction along the ends of the stator and rotor, which will lead to destabilization of the system in the transverse direction and attraction of the ends. Since this interaction is constant throughout the rotor motion (except for minor oscillations due to the presence of gaps in the stator), this phenomenon is only accounted for in the magnitude of the levitation force in the graphs.

The 2D diagram (Figure 24) identified a similar edge effect at the locations where the ends of the rotor and stator magnets coincide. Since these forces are discrete, they cause levitation force variations (downwards) and lead to galloping of the rotor. The frequency of oscillations depends on the geometrical dimensions of PMs of the stator and rotor.

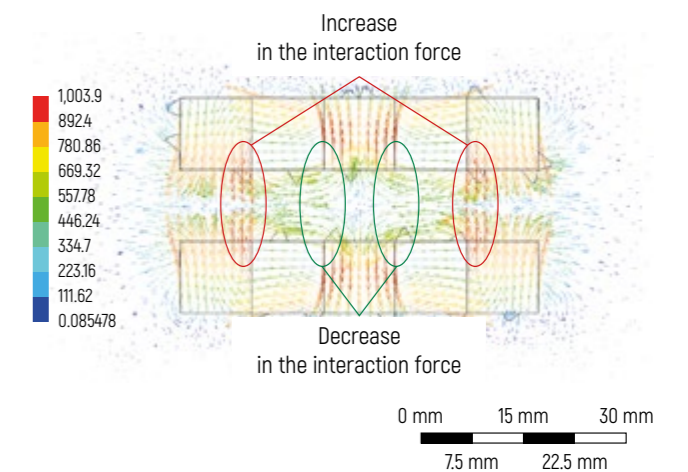

Figure 24 – 2D diagram of force vectors when plane neodymium magnets are used, mT

Based on the conducted calculations and analysis of data from two directions of research of levitating PMs, it was decided to create a system where the stator and rotor consist of cubic magnets spatially oriented according to the Halbach array scheme [5]. The size of the magnets is $10 \times 10 \times 10$ mm. Spacing between the arrays is 10 mm. The geometric size of the magnet does not matter and does not affect the final result.

The results of modeling and calculations (Figures 25, 26, Table 3) show the complete impossibility of using two-dimensional Halbach arrays to solve the problem at hand.

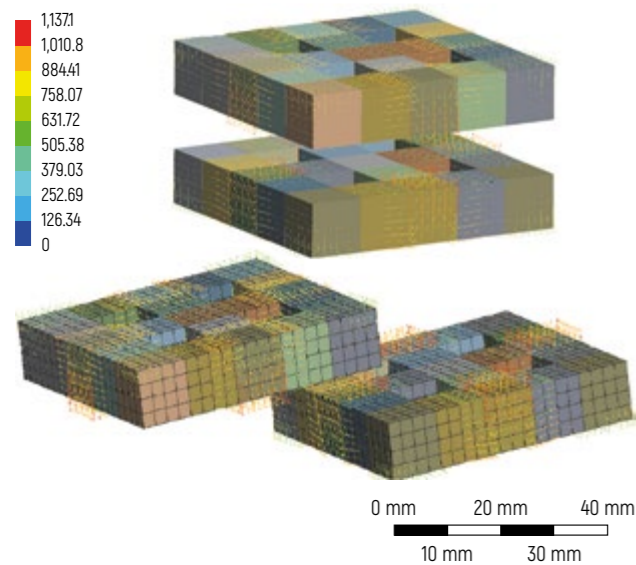

Figure 25 – 3D diagram of force vectors when arrays are arranged opposite to each other and with a displacement, mT

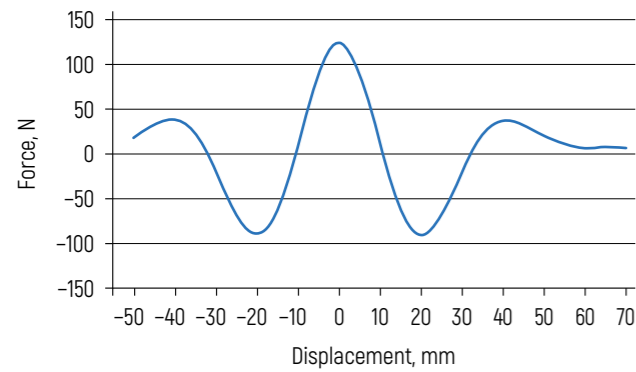

Figure 26 – Dependence graph of force on the displacement of one two-dimensional Halbach array relative to another

Thus, the magnet configuration shown in Figure 19 appears to be the most promising. The model was further improved in order to minimize the edge effects that increase the resistance to motion. The magnets have obtained roundings (Figure 27).

Figures 28 and 29 show the dependences of the resistance forces to rotor motion on its displacement at rectangular and vaulted shapes of magnets.

As can be seen from the graphs (Figures 28, 29), the resistance force to movement practically does not depend on the shape of magnets, however, the lifting force in case of using vaulted magnets is 14 % higher (Figures 30, 31).

Table 3 – Dependence of the interaction force of two two-dimensional Halbach arrays on their mutual displacement

Displacement, mm	Force, N
-50	18.6
-45	32.3
-40	37.7
-35	21.2
-30	-20.83
-25	-68.95
-20	-88.72
-15	-62.36
-10	11.95
-5	90.59
0	123.76
5	89.09
10	11.06
15	-61.04
20	-90.69
25	-68.57
30	-21.46
35	21.53
40	36.81
45	32.42
50	20.17
55	11.83
60	6.22
65	7.86
70	6.77

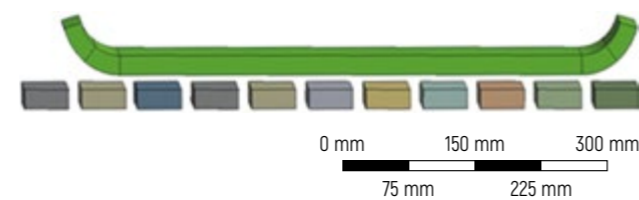

Figure 27 – Vaulted magnet of the rotor

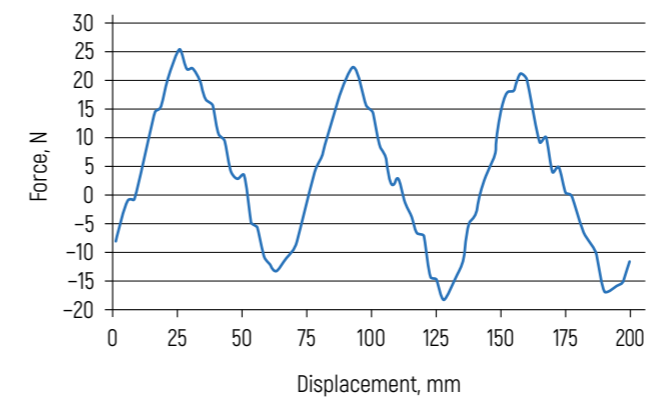

Figure 28 – Dependence graph of longitudinal force of resistance to rotor motion on its displacement at rectangular shape of magnets

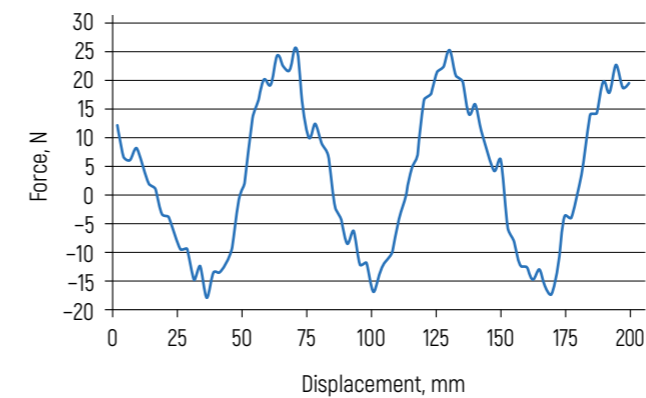

Figure 29 – Dependence graph of longitudinal force of resistance to rotor motion on its displacement at vaulted shape of magnets

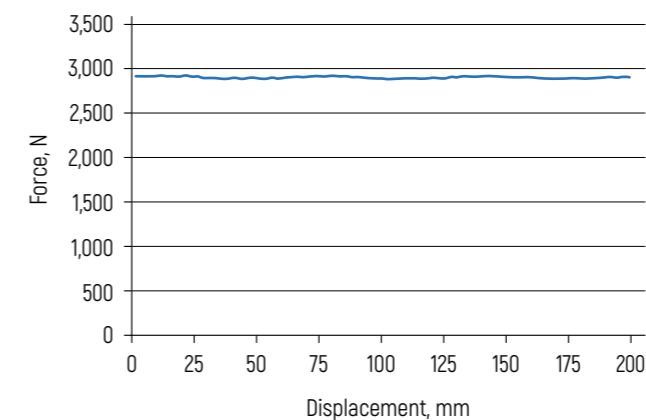

Figure 30 – Dependence graph of lifting force on rotor displacement at rectangular shape of magnets

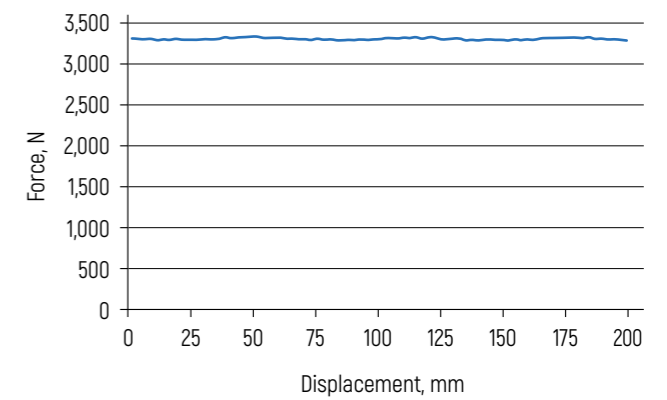

Figure 31 – Dependence graph of lifting force on rotor displacement at vaulted shape of magnets

Conclusion

The obtained values of specific forces of magnets interaction at a given arrangement and different lengths of rotor magnets showed a decrease in the scatter between the maximum and minimum values of the force when increasing the length of rotor magnets from 500 mm (6 %) to 650 mm (3.2 %). The rotor arrangement with magnets length of 575 mm showed the worst result on the scatter – 8.6 %. Herewith it should be noted that the average value of oscillations decreases from 2.1 % at 500 mm to 1.1 % at 650 mm; the rotor with magnets of 575 mm length also had the worst index – 3.3 %.

After verifying the simulation results with a full-scale model, it is envisaged to create a design that implements the magnetic suspension properly and meets all the requirements.

At the further stage of research, it is supposed to work out the design excluding the exit of magnets force lines outside the rotor and, accordingly, removing their interaction with stator magnets. Thus, it is planned to bring the efficiency factor of the magnetic suspension system of the GPV linear rotors even closer to 100 %.

References

1. Malykh, G.I. *Kratkaya istoriya razvitiya transportnoy tekhniki [Brief History of the Development of Transportation Technology] / G.I. Malykh // Sovremennyye tekhnologii. Sistemnyy analiz. Modelirovaniye. – 2009. – No. 1 [21]. – P. 169–172.*

2. Unitsky, A. *String Transport Systems: On Earth and in Space* / A. Unitsky. – Silakrogs: PNB Print, 2019. – 560 p.
3. Unitsky, A. *Creating of a Mathematical Model of the General Planetary Vehicle: Accelerating Flywheels, Passing the Atmosphere, Going into Orbit* / A. Unitsky, R. Sharshov, A. Abakumov // *Non-Rocket Space Industrialization: Problems, Ideas, Projects: Collection of Articles of the II International Scientific and Technical Conference, Maryina Gorka, Jun. 21, 2019* / Astroengineering Technologies LLC; ed. A. Unitsky. – Minsk: Paradox, 2019. – P. 77–83.
4. Antonov, Yu.F. *Razrabotka model'noy ustanovki i issledovaniye levitatsii i bokovoy stabilizatsii platformy s ispol'zovaniyem vysokotemperaturnykh sverkhprovodnikov vtorogo pokoleniya* [Development of Model Installation and Research of Levitation and Lateral Stabilization of the Platform Using High-Temperature Superconductors of the Second Generation] / Yu.F. Antonov // *Innovatsionnyye transportnyye sistemy i tekhnologii*. – 2015. – Vol. 1, No. 2. – P. 62–84.
5. Moser, R. *Optimization of Two-Dimensional Permanent Magnet Arrays for Diamagnetic Levitation* [Electronic resource] / R. Moser, F. Barrot, H. Bleuler // *17th International Conference on Magnetically Levitated Systems and Linear Drives (Maglev 2002)*. – Lausanne, 2002. – Mode of access: http://www.maglev.ir/eng/documents/papers/conferences/maglev2002/topic10/IMT_CP_M2002_T10_S1_2.pdf. – Date of access: 23.08.2023.





UDC 621.313.84:681.537:681.586.57

Control Algorithms and Tests of the Prototype of Linear Electric Motor of the General Planetary Vehicle

A. Abakumov

M. Zimiankou

Unitsky String Technologies Inc.,
Minsk, Belarus



The authors describe the prototype of a linear electric motor with magnetic levitation on permanent magnets developed for the General Planetary Vehicle (GPV). There are configurations of the stator magnets which allowed to achieve an optimal shape of the magnetic pad and sufficient repulsive force. A rotor stabilization algorithm based on proportional-integral-derivative controllers is given. The article also contains the results of tests performed with the help of the test bench.

Keywords:

control system, General Planetary Vehicle (GPV), linear motor, magnetic levitation.

Introduction

A linear electric motor is the key structural element of the General Planetary Vehicle (GPV); its development is considered a priority of the global uSpace geocosmic program, proposed by engineer A. Unitsky [1–3]. High rotor speeds impose serious requirements to the motor parameters. To obtain them, it is necessary to solve a number of engineering problems, the main of which is to achieve minimum power consumption in steady-state mode and to ensure efficiency factor close to 100 % during linear rotor acceleration and recovery of its kinetic energy.

These issues are being addressed in two different ways: the development of a rotor magnetic levitation system inside the stator body and designing of a linear motor that accelerates the rotor to a speed of 12–15 km/s required to launch the GPV from the Earth's surface [4].

In order to levitate the rotor at the indicated speed, it is assumed that the system based on the Meissner effect (quantum levitation on superconductors) will have the lowest power consumption [5]. The design is composed so that the permanent magnets are continuously positioned on the rotor and their polarity is oriented in the same direction, and the superconductors are located on the stator together with the cooling system and thermal insulation. The magnetic field, constant in its value along the main axis of the motor, ensures a free sliding of the rotor along the stator, while fixing it in the transverse direction due to the emergence of the magnetic field strength gradient.

This design is passive from the viewpoint of control systems; its application requires an additional active system that performs the following functions: initial rotor hanging-out, position correction, damping of dynamic oscillations and possible emergency support [6]. An electromagnetic stabilization on direct current electromagnets is proposed as such a system. This option is well compatible with the levitation system on superconductors, since it also requires allocation of permanent magnets of the same orientation on the rotor.

The initial task is to design a test bench with electromagnetic stabilization and an accelerating system, which will allow to verify the general concept of the electric motor, its mathematical model and control system as well as to evaluate the negative phenomena for further more detailed designing of the motor.

This article describes the results of the development of this test bench.

Description of the Hardware Part of the Test Bench

The test bench is a levitating ring rotor having an external metal rim and a stator platform (Figures 1–3).

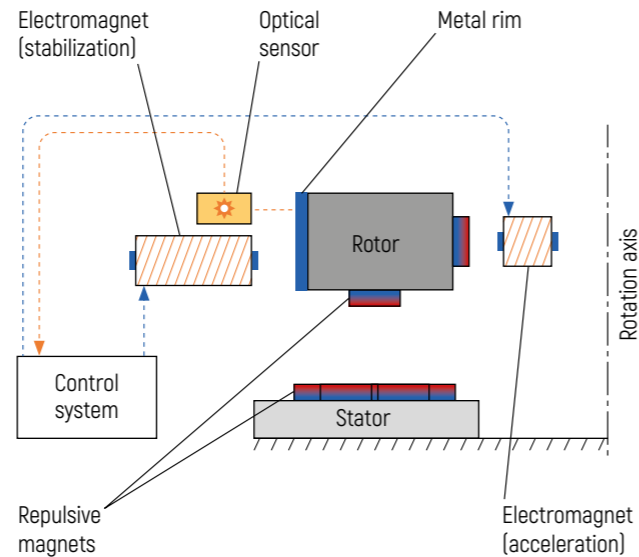

Figure 1 – Functional diagram of the test bench ring model

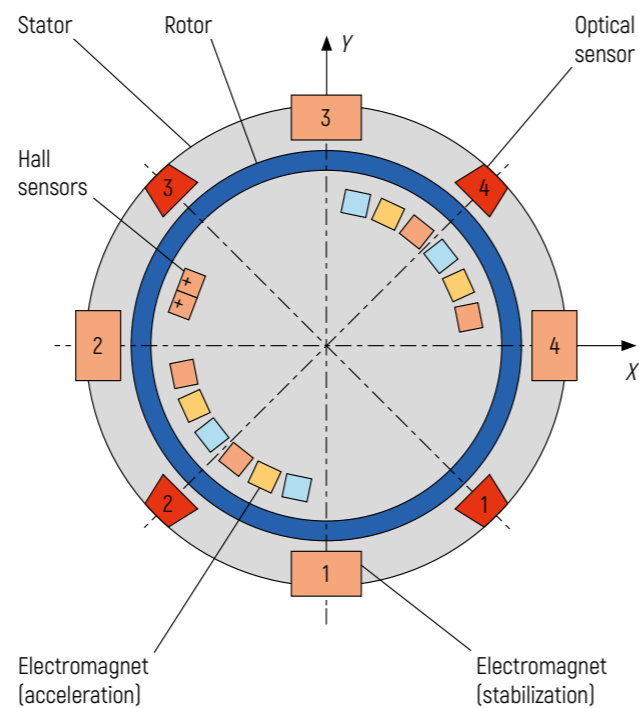

Figure 2 – Diagram of the test bench (top view)

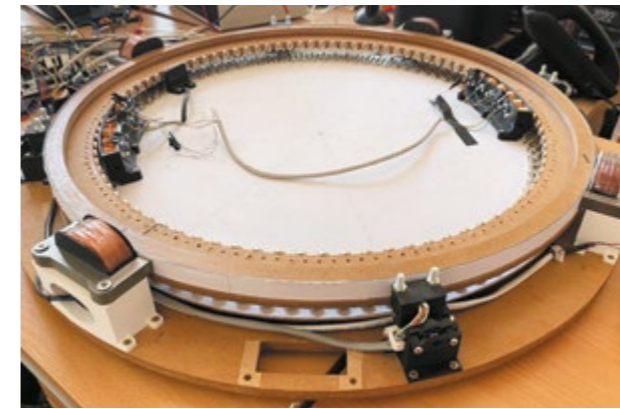

Figure 3 – Experimental test bench developed by Unitsky String Technologies Inc. (Minsk, 2023)

Since it is impossible to obtain a stable equilibrium by means of permanent magnets alone, a hybrid levitation pattern is used: permanent magnets hold the rotor vertically, accepting all its weight, and electromagnets fix the rotor in a horizontal position, balancing it at the point of unstable equilibrium and preventing it from stalling. Thus, due to the absence of the need to hold its own weight with electromagnets constantly, the power consumption of the levitation system is minimized.

The position of the rotor relatively to the equilibrium point is determined by four optical stator sensors that transmit data to the control system, which is in charge of the direct conversion of the received signal. Then a control signal is sent to four electromagnets that stabilize the horizontal movement of the rotor.

The rotor is driven by a motor based on the principle of a brushless electric motor on permanent magnets with a vector control. For this purpose, permanent magnets of alternating polarity are located on the rotor, and two groups of accelerating electric motor coils are mounted on the stator. The use of this type of motor simplifies the rotor design to the maximum extent and provides the possibility of regenerative braking for energy return. The rotor phase angle required for motor operation is measured by two Hall sensors.

Figure 4 shows the structural diagram of the test bench.

The system is based on the STM32 microcontroller of the Nucleo H743ZI2 debug board carrying out all mathematical calculations and is responsible for the control logic. This board was chosen because of its high performance and the large number of analog-to-digital converter (ADC) channels with a resolution of up to 16 bits, which is required by the sensor system due to the need for maximum accuracy and speed of measurement.

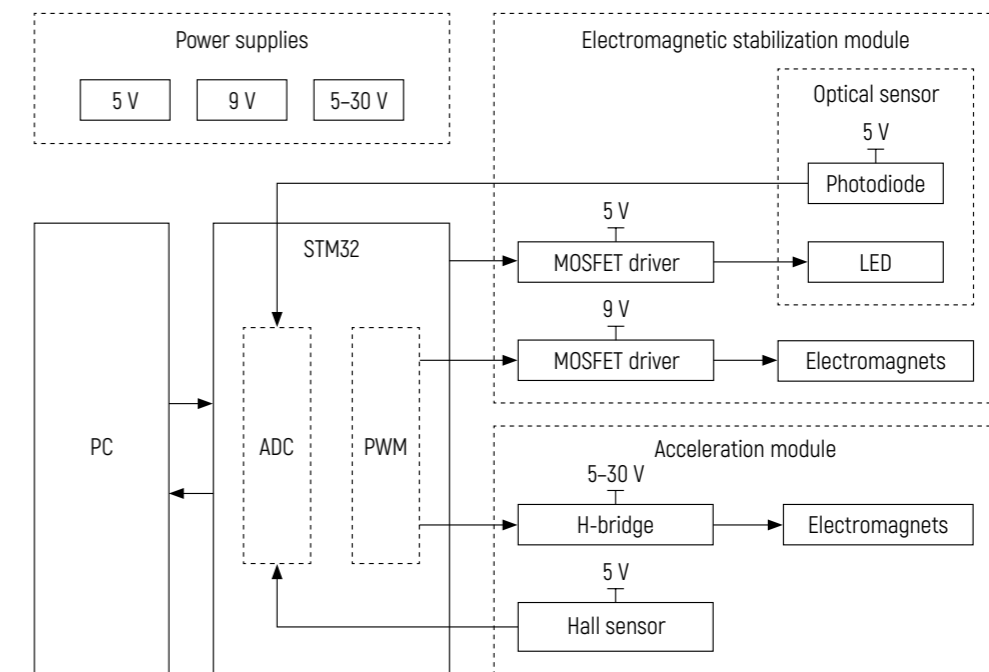

Figure 4 – Structural diagram of the test bench

The debug board communicates with the stabilization and acceleration modules by means of the ADC, with the help of which the input continuous signal is fed to the controller as a discrete signal. To effectively control external devices, a pulse width modulation (PWM) is used – a method of encoding a specified analog signal by changing the duration of impulses of constant frequency.

Electromagnetic Stabilization Module

Since the output voltage on the Nucleo debug board is 3.3 V, the high-power load is controlled by a MOSFET driver connected to a higher voltage source. For the optical sensors to function, control impulses of 3.3 V amplitude are supplied to the driver, resulting in the appearance of 5 V amplitude operating impulses on a group of LEDs. They, in turn, emit light, part of which, reflected from an external object, returns to the receiver, i.e., photodiode. Depending on the amount of reflected light, the photodiode transmits an analog signal to the ADC of the controller, where it is further processed.

The stabilization electromagnets are also controlled via a MOSFET driver with a galvanic separation. The electrical isolation ensures that the signal circuit is independent of the power circuit, which increases noise immunity and connection safety. After all transformations, PWM signals of preset durations are supplied to the electromagnet driver to create a variable force of attraction.

Acceleration Module

The acceleration electromagnets are controlled by a bridge driver (H-bridge). This element of the system allows to change the direction of the load current while sending a combination of enabling signals to the driver transistors from the digital outputs of the debug board. This leads to a reversal of the electromagnet polarity to either attract or repel, making the stator a source of an alternating magnetic field that interacts with the rotor as a source of a direct current field.

The analog Hall sensors are intended to determine the rotor angular position and its rotational speed. The signals are read out via the ADC. Three power supplies serve for the operation of the system units. The personal computer (PC) is used to debug the control system, change the operating modes of the test bench, input and output the parameters.

The key parameters of the test bench elements are summarized in Table 1.

Table 1 – Basic parameters of the test bench elements

Parameter	Value
Test bench dimensions (diameter × height), mm	640 × 75
Rotor dimensions (outer diameter × inner diameter × height), mm	552 × 472 × 22
Rotor weight, g	1,250
Number of stator magnets, pcs	450
Number of rotor magnets (levitation), pcs	150
Number of rotor magnets (acceleration), pcs	92
Vertical clearance between rotor and stator magnets in levitation state, mm	13
Clearance between rotor and stabilization coils, mm	2–3
Number of stabilization coils, pcs	4
Voltage of stabilization coils, V	9
Inductance of stabilization coils, mH	50–80 (depending on the distance to the rotor)
Resistance of stabilization coil, Ω	5.3
Number of turns of stabilization coil	800
Wire thickness of stabilization coil, mm	0.6
Switching time of stabilization electromagnet driver, μs	5
Number of acceleration coils, pcs	12
Voltage of acceleration coils, V	9; 12; 15
Inductance of acceleration coil, mH	4.1
Resistance of acceleration coil, Ω	4.1
Number of turns of acceleration coil	600
Wire thickness of acceleration coil, mm	0.4
Debug board	STM32 Nucleo H743ZI2
Performance, MHz	480
Number of optical sensors, pcs	4
Maximum frequency of sensors (LED) operation, kHz	100
Switching time of optical sensors driver, ns	25
Number of Hall sensors, pcs	2
Magnetic sensitivity, G	±1,000
Response time, μs	3

Configurations of Permanent Repulsive Magnets for Rotor Hanging-Out

To achieve a large repulsive force, neodymium magnets with a significant value of magnetic induction are used. For convenience of mounting on the test bench, magnets with a diameter of 10 mm and a height of 3 mm are chosen. A preliminary assessment of the magnetic field distribution is shown in Figure 5.

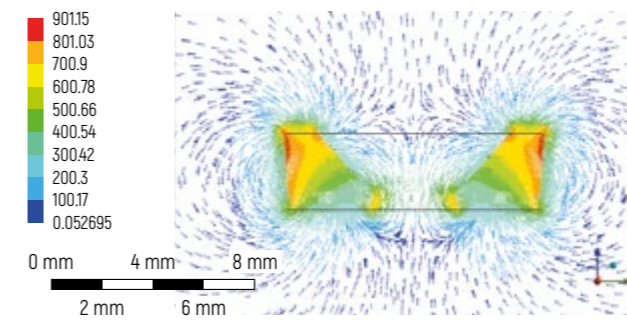

Figure 5 – Distribution of magnetic induction field of the magnet, mT

Figure 6 shows the stator magnet configurations with the corresponding repulsive force distributions.

Initially, one row of permanent magnets was used on the stator and rotor. This configuration (Figure 6, variant 1) had a weak lifting force and a narrow area of equilibrium, which led to a slight stalling of the rotor and its sticking to the stator due to the edge effect of the magnets.

The addition of two extra rows of magnets on the stator (Figure 6, variant 2) widened the levitation area, but a transverse magnetic wave appeared, which did not solve the problem of rotor sticking between the magnets.

The next variant of the magnet configuration (Figure 6, variant 3) allowed to achieve a more uniform platform: there are no pronounced transverse magnetic waves, the problem of rapid rotor stalling at small displacements disappeared.

The configuration (Figure 6, variant 4) consisting of rectangular magnets of 30 × 14 × 4 mm was also calculated. This variant shows a more acceptable result of vertical repulsive force and magnetic field width. However, due to the difficulty of ordering sector magnets, this configuration was not used in the considered test bench.

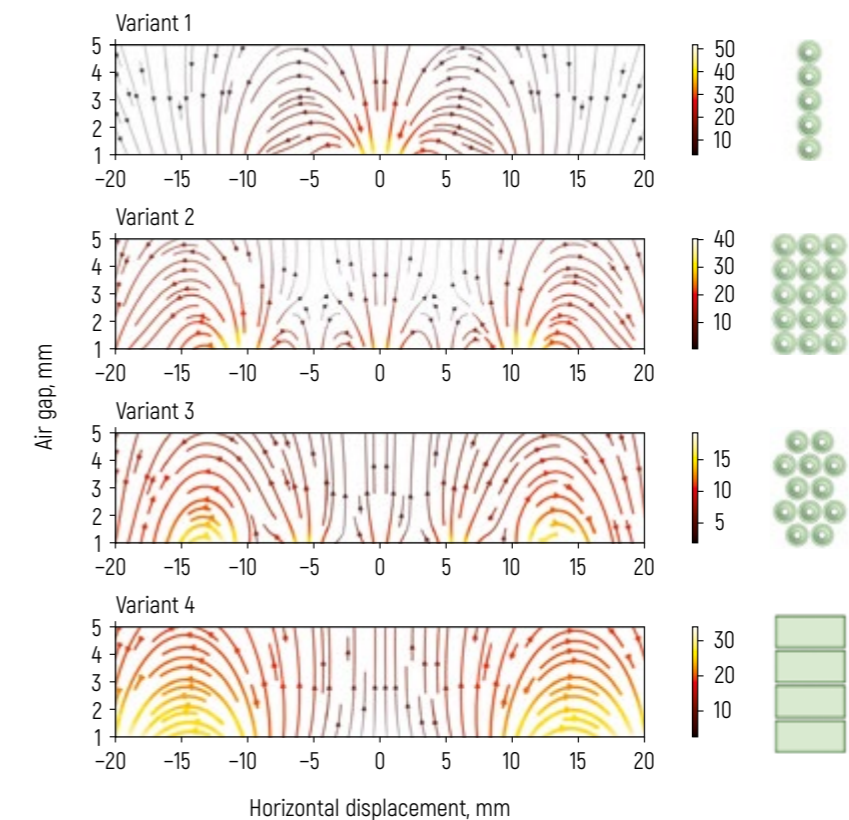

Figure 6 – Variants of stator magnet configurations (right). Vector maps of repulsive forces (left)

Description of the Control System Operation Algorithm

The key factor in designing of the magnetic levitation system is the optimal control of electromagnetic forces. The system used is divided into two parts: stabilizing and accelerating. The first is responsible for maintaining a stable position of the rotor, controlling and correcting the electromagnetic forces so as to compensate for any perturbations. The second is necessary to create a running magnetic field, which sets in motion the already levitating rotor of the motor. Each part of the system will be discussed in more detail below.

Stabilizing Part

Figure 7 shows the control system responsible for horizontal stabilization of the rotor using electromagnetic coils.

The mode control unit is an external device that determines the further behavior of the system: main mode or calibration mode. The first mode directly turns on the stabilization coils and leads the system to the levitation state. The second mode allows the operation of the calibration unit, where the optical sensors are aligned and their position is adjusted to compensate for measurement errors before the main mode is started.

The optical sensor unit arranges the selection of access channels to the sensor devices. The sensor control unit implements the logic of their operation [Figure 8].

Impulses with a period of 1 ms (1 kHz) and a width of 50 % are supplied to the infrared LED. The photodetector takes measurements with a period of 0.1 ms (10 kHz) and averages them on five values. The difference between the photodiode measurements when the LED is on and off is then calculated and corrected by table coefficients to determine the air gap (in millimeters) between the sensors and the rotor. This system provides measurement accuracy of about ± 0.05 mm.

The rotor coordinate calculation unit (Figure 9) uses the air gap values from the optical sensor unit to establish the position of the rotor center in the stator coordinate system.

The levitation control system unit implements a rotor position control algorithm based on a two-stage PID controller (Figure 10).

The first controller receives information about the deviation of the rotor position from the equilibrium point and outputs the desired speed at which it should return. The second one evaluates the difference between the actual and target speeds and transmits a PWM control signal to the unit of electromagnets. The maximum stiffness and optimum speed of system response are achieved with the coefficients of PID controllers given in Table 2. Thus, the "rotor - stator" system described by the equations of the second-order motion is controlled by two inserted first-order controllers.

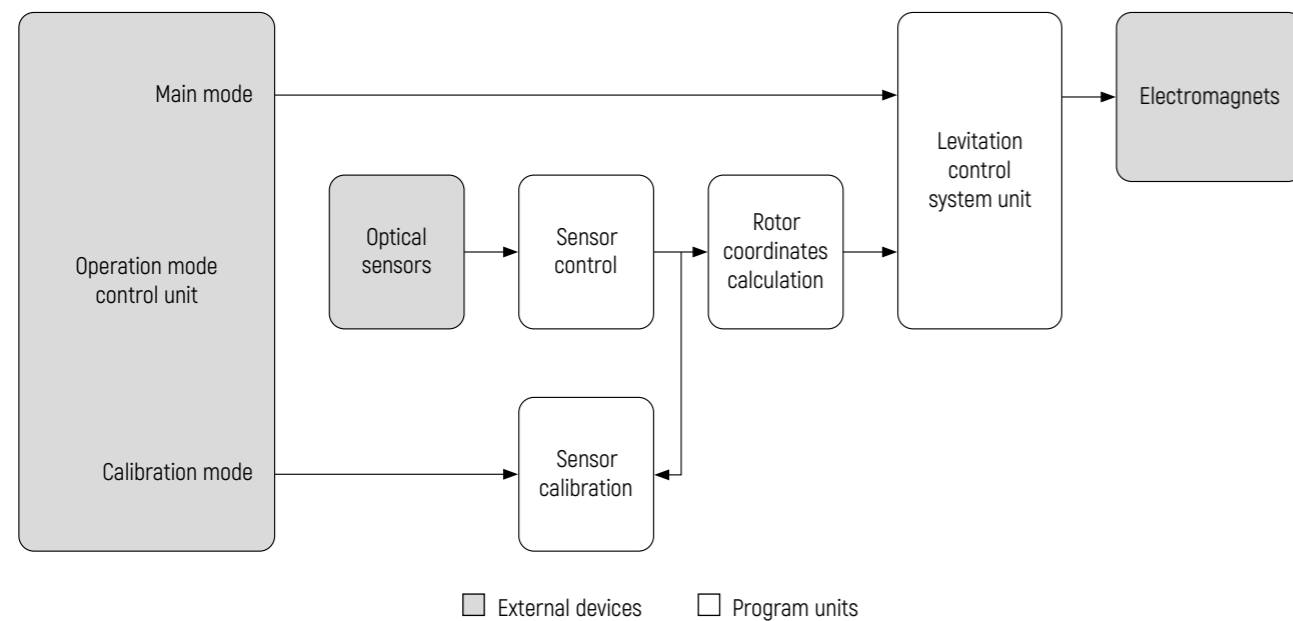

Figure 7 - Flowchart of the stabilization control system

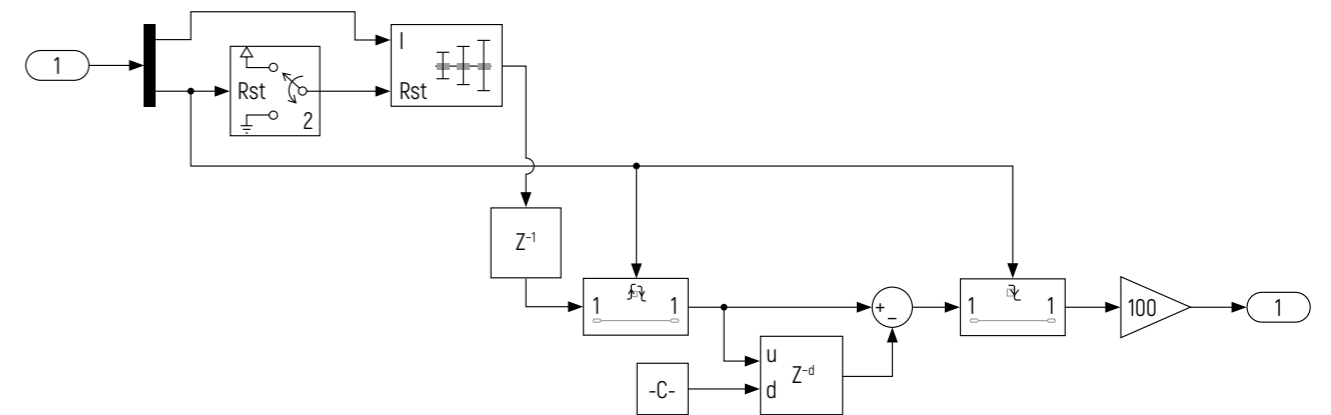

Figure 8 - Optical sensor control unit

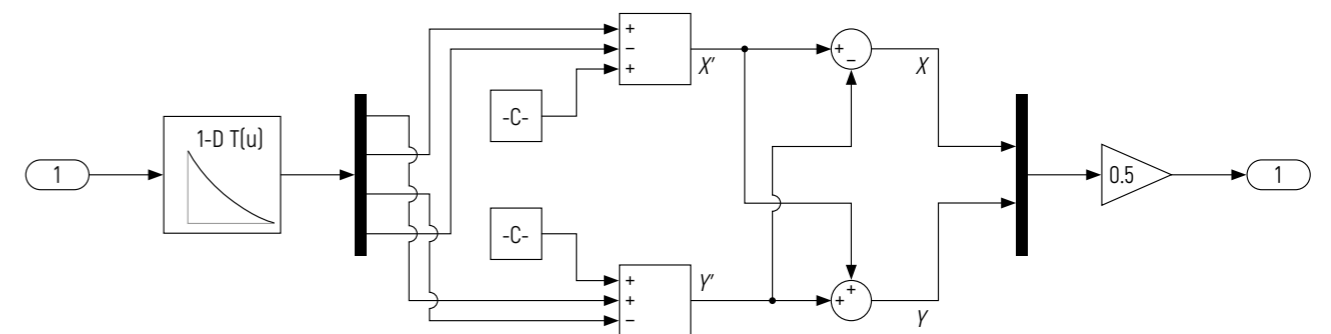

Figure 9 - Rotor coordinate calculation unit

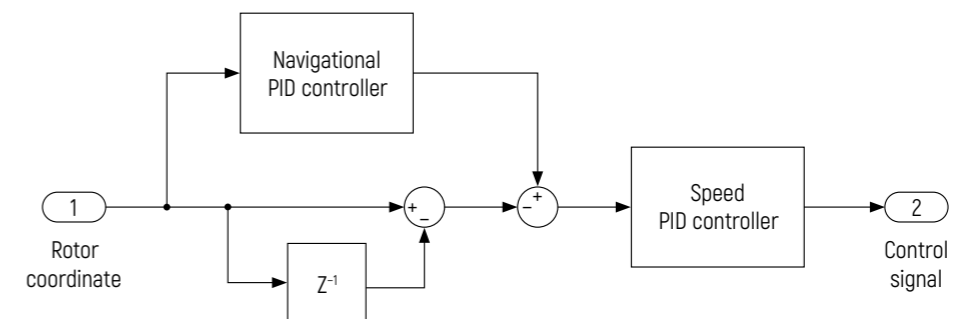

Figure 10 - Controllers of the levitation control system unit

Table 2 - Coefficients of PID controllers

PID controller	K_p	K_i	K_d
Navigational	-1	-0.1	-0.0001
Speed	40	300	1

Accelerating Part

The control system responsible for rotor acceleration (Figure 11) operates without data exchange with the stabilizing part for carrying out their independent debugging.

The acceleration algorithm is based on the vector control, which allows to control the torque directly as well as the applied power and the rotor speed by adjusting the amplitude, the phase and frequency of electromagnet voltages.

The mechanical angle measurement unit determines the rotor position and shapes the direction of the stator current vector (Figure 12). The values of voltage amplitudes proportional to the rotor phase angle are taken from two analog Hall sensors having a phase offset of 270° (1.5 steps of acceleration magnet placement).

In addition, compensation for inaccurate sensor positioning is introduced. This step makes it possible to set a 90°

offset of the stator current phase from the rotor phase, at which the maximum torque value is achieved.

The rotor speed measurement unit determines the angular and linear speed by the change of the rotor phase angle value in time, taking into account the number of accelerating magnets: 92 magnets, or 46 pole pairs.

The control unit (Figure 13) is responsible for the algorithm of rotor speed maintenance.

Thus, in case of deviation from the target speed value, the PI controller ($K_p = -0.4$; $K_i = -0.00001$) generates a control signal proportional to the error.

Based on the direction of the total stator current vector and the setting amplitude of the electromagnet voltage, a three-phase sinusoidal signal is sent. Each of its phases goes to the acceleration coil unit, where it is converted into a PWM signal.

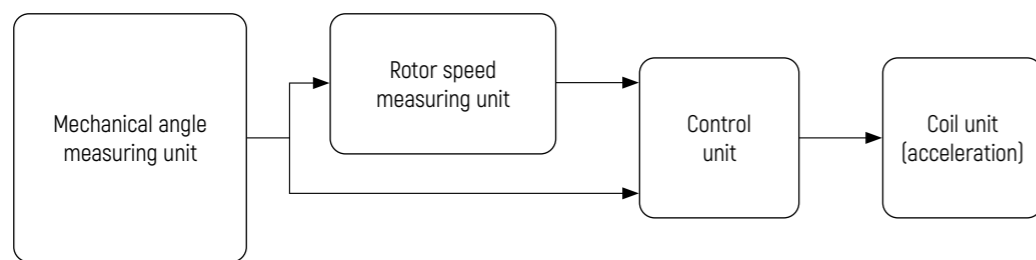

Figure 11 – Flowchart of the acceleration control system

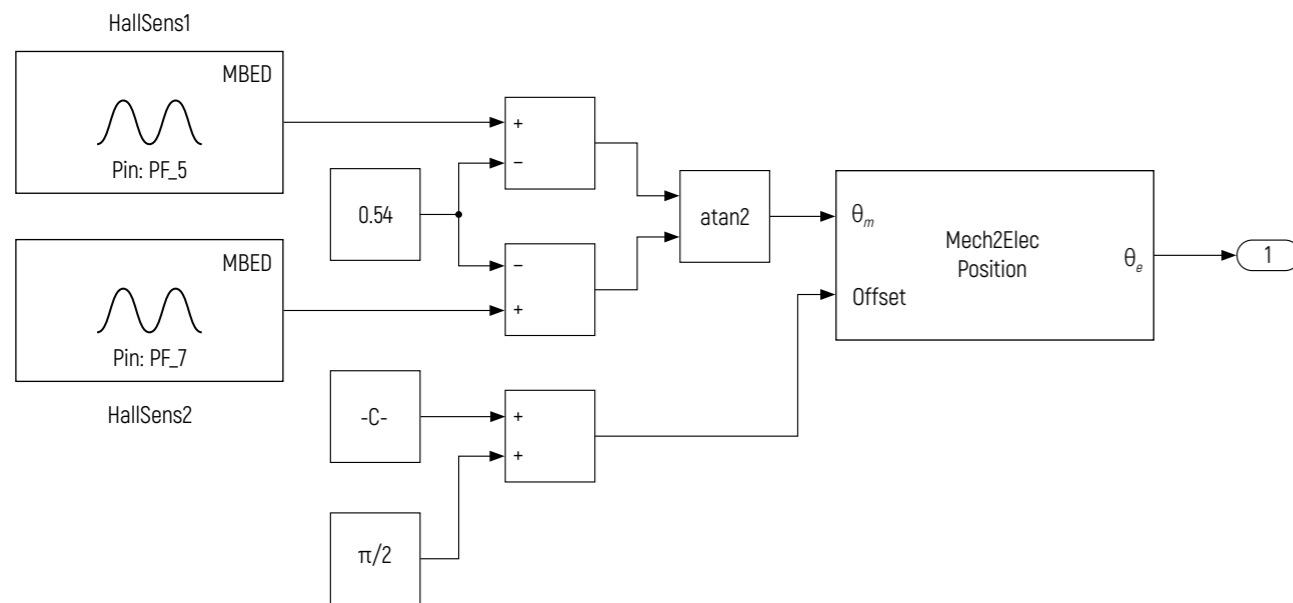

Figure 12 – Mechanical angle measurement unit

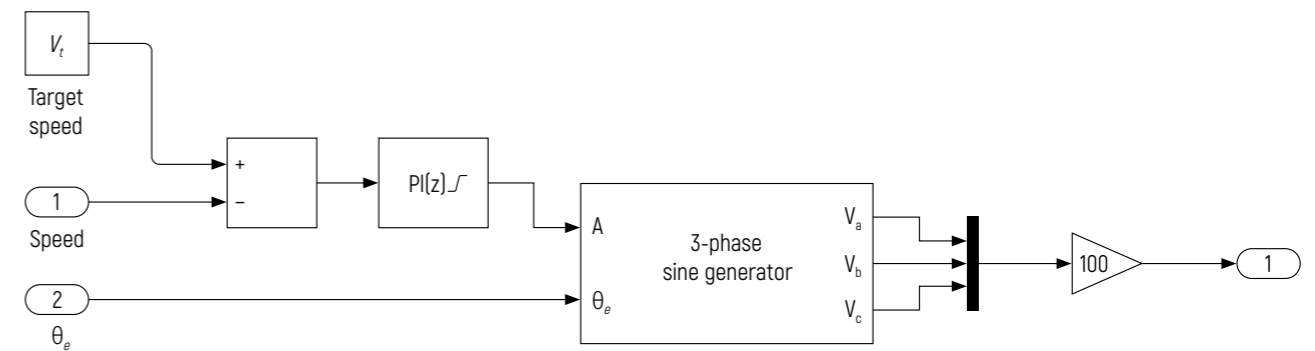

Figure 13 – Control unit

Test Results

Selection of all controller coefficients has been performed manually. The main criterion is to determine the values at which the rotor stays steadily in the equilibrium point. For this purpose, the control system should have high rigidity, i.e., fast adjustment to an external impact, and absence of self-oscillations.

The object of control is characterized by a large nonlinearity. The behavior of the rotor in the current configuration is comparable to the behavior of a ball on a hill (Figure 14). When balancing at the point of unstable equilibrium, the perturbing effect changes its direction to the opposite one, which leads to self-oscillations. In this case, the amplitude of oscillations is determined by the sharpness of the peak (how much the perturbing force changes depending on the deviation from the equilibrium point) and the speed of response from the control system. Such oscillations were obtained as a result of the experiment on the test bench (Figure 15).

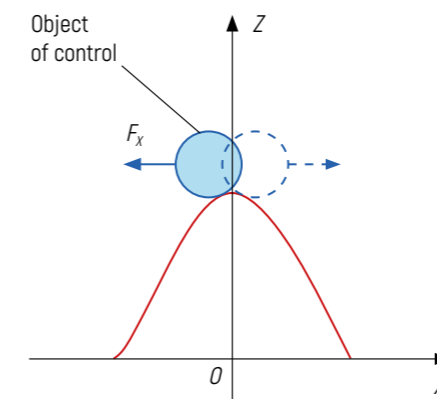

Figure 14 – Maintaining the object of control at the point of unstable equilibrium

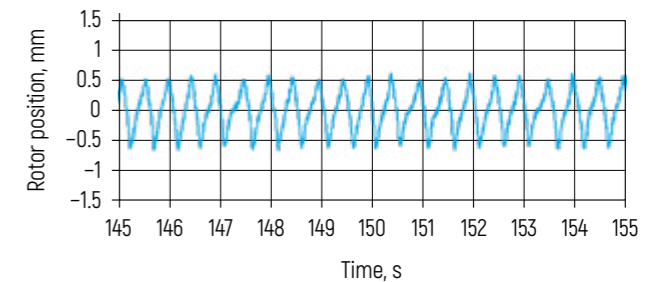

Figure 15 – Rotor oscillations around the equilibrium point

To solve this problem, the object of control is shifted aside from the equilibrium point by a minimum value. Thus, the perturbing effect does not drastically change its direction, therefore, it is easier for the control system to maintain equilibrium (Figure 16).

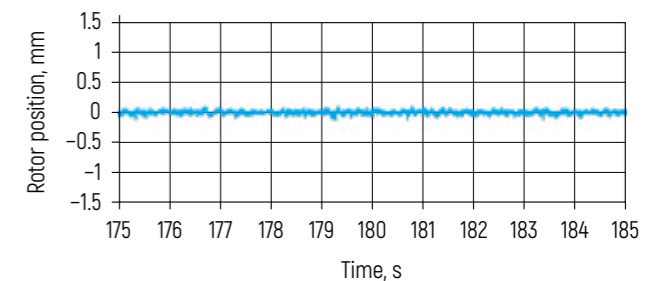

Figure 16 – Rotor stabilization after displacement from the equilibrium point

The response of the stabilization control system was evaluated by applying an external single impulse impact on the rotor. The equilibrium recovery time was 0.45 s, which indicates a rather low stabilization speed at the current

parameters of PID controllers (Figures 17, 18). An attempt to increase the speed of reaction by changing the coefficients leads to the formation of self-oscillations in the system.

Achievement of a sufficient level of stabilization allowed us to proceed to debugging of the accelerating part. Table 3 shows information about the rotor acceleration at different voltages applied to the acceleration electromagnets.

Figure 19 shows the results of rotor acceleration to evaluate the effect of voltage on the acceleration speed. As the supply voltage increases, the time to reach the required rotor speed decreases.

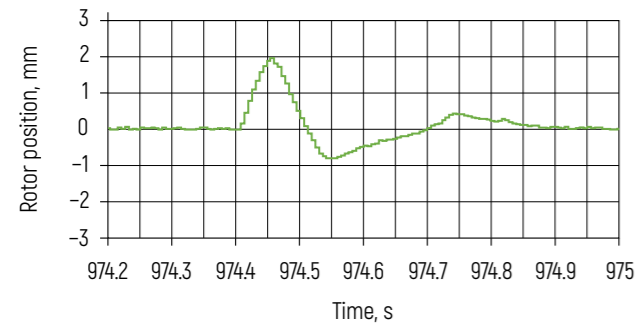

Figure 17 – System response to an external single impulse effect

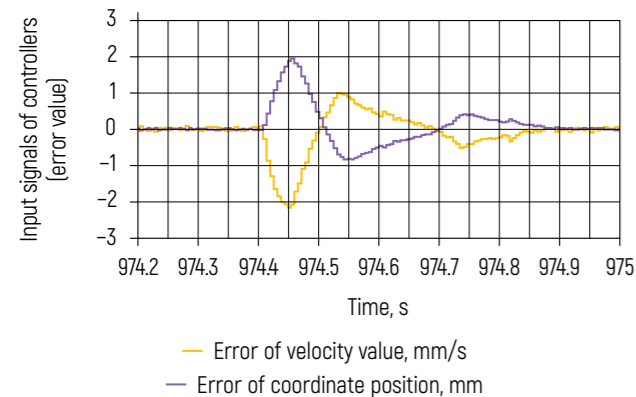

Figure 18 – Errors of stabilization controllers on external single impulse effect

Table 3 – Data on rotor acceleration to 145 rpm [4.1 m/s]

Voltage, V	Acceleration time 0–145 rpm, s	Inrush current, A	Acceleration current, A	Speed maintaining current, A
9	90	0.45	0.2	0.13
12	27	0.65	0.3	0.11
15	20	0.82	0.35	0.09

There is the result of electric motor acceleration and then deceleration of the rotor after disconnection of accelerating coils and the absence of active braking at Figure 20. The supply voltage of the accelerating coils is 12 V. Stabilizing coils continue to operate, which prevents the rotor from touching the cores.

The time to rotor stopping from a speed of 145 rpm is 133 s. Such a high rate of rotor deceleration requires further investigation to evaluate the effect of various factors (structural damping, magnetic friction, air resistance, etc.).

Appropriate vibration level measurements were made to determine the stability of the levitation control system during rotor rotation. Root mean square values of horizontal deviations of the rotor from the target value were analyzed (Figure 21).

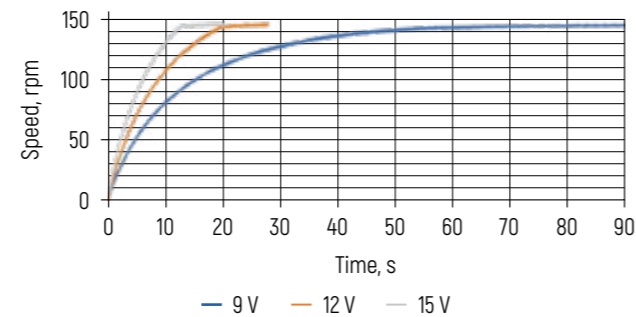

Figure 19 – Rotor acceleration time at different voltages of the accelerating coils

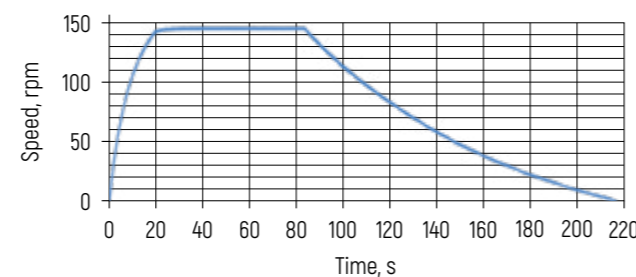

Figure 20 – Result of rotor acceleration and deceleration

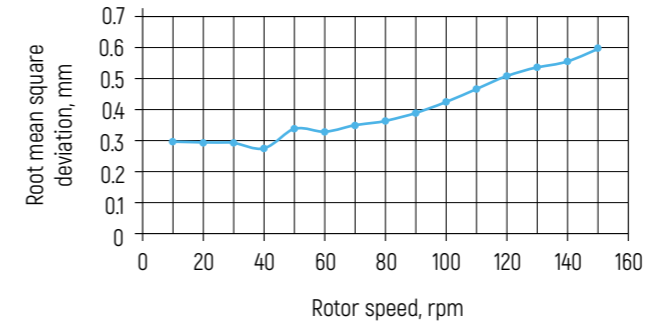

Figure 21 – Measured transverse vibrations of the rotor at different rotation speeds

Besides, the problem of vertical oscillations of the rotor was diagnosed in the developed test bench. The permanent magnets supporting the rotor are actually a nonlinear spring with ultrasmall damping, so it is sufficient to have a small nonuniformity of the supporting magnetic field to obtain increasing vertical oscillations of the rotor when it rotates at resonant speeds. The oscillation period is 0.28 s. This effect confirms the necessity of using an active stabilization system alongside with a passive one.

Conclusion

In order to modernize the existing experimental test bench, it is necessary to collect data on the dependence of the effect of all parameters on the behavior of the system. The following tasks have been identified as key areas for further work:

- implementation of feedback on current to improve the quality of acceleration and stabilization algorithms;
- implementation of the recuperation system;
- evaluation of the actual efficiency factor and the possibility of its raising, determination of the sources of energy losses and minimization of their impact on the system operation;
- improvement of sensor system characteristics to increase its speed and accuracy;
- optimizing the configuration of permanent magnets supporting the rotor, improving the uniformity of the magnetic field;
- evaluation and consideration of time delays in the control system and increasing the speed of transition processes of the hardware part of the system;

- creation of the mathematical model of the magnetic levitation system, evaluation of the criteria of control system stability;
- transition from the PID controller to the controller based on predictive models.

All the data collected from the experimental test bench will be used to draw a mathematical model of the electric motor, which is necessary to generate the requirements for the hardware and control system of the GPV.

A thorough study of all GPV aspects is an important stage in the development of geocosmic transport. Work on extending the functionality of the prototype of a linear electric motor with magnetic levitation will make it possible to verify the safety and efficiency of the project, which will prepare the GPV system for practical full-scale implementation.

References

1. *Non-Rocket Near Space Industrialization: Problems, Ideas, Projects: Collection of Articles of the V International Scientific and Technical Conference, Maryina Gorka, Sep. 23–24, 2022 / Astroengineering Technologies LLC, Unitsky String Technologies Inc.; ed. A. Unitsky. – Minsk: Stray-MediaProject, 2023. – 320 p.*
2. *Unitsky, A. The Engineer: Autobiography / Anatoli Unitsky. – Minsk, 2020. – 400 p.: ill.*
3. *Unitsky, A. System Foundations of Non-Rocket Near Space Industrialization: Problems, Ideas, Projects / A. Unitsky. – Minsk: Gradient, 2021. – 568 p.*
4. *Unitsky, A. Creating a Mathematical Model of the General Planetary Vehicle: Accelerating Flywheel, Passing the Atmosphere, Going into Orbit / A. Unitsky, R. Sharshov, A. Abakumov // Non-Rocket Space Industrialization: Problems, Ideas, Projects: Collection of Articles of the II International Scientific and Technical Conference, Maryina Gorka, Jun. 21, 2019 / Astroengineering Technologies LLC; ed. A. Unitsky. – Minsk: Paradox, 2019. – P. 77–83.*
5. *The Interaction Force Between a Permanent Magnet and a Superconducting Ring / F.Y. Alzoubi [et al.] // IEEE Transactions on Applied Superconductivity. – 2007. – Vol. 17, iss. 3. – P. 3814–3818.*
6. *Experiments and Simulations of the Secondary Suspension System to Improve the Dynamic Characteristics of HTS Maglev / H. Li [et al.] // IEEE Transactions on Applied Superconductivity. – 2021. – Vol. 31, iss. 6. – P. 1–8.*

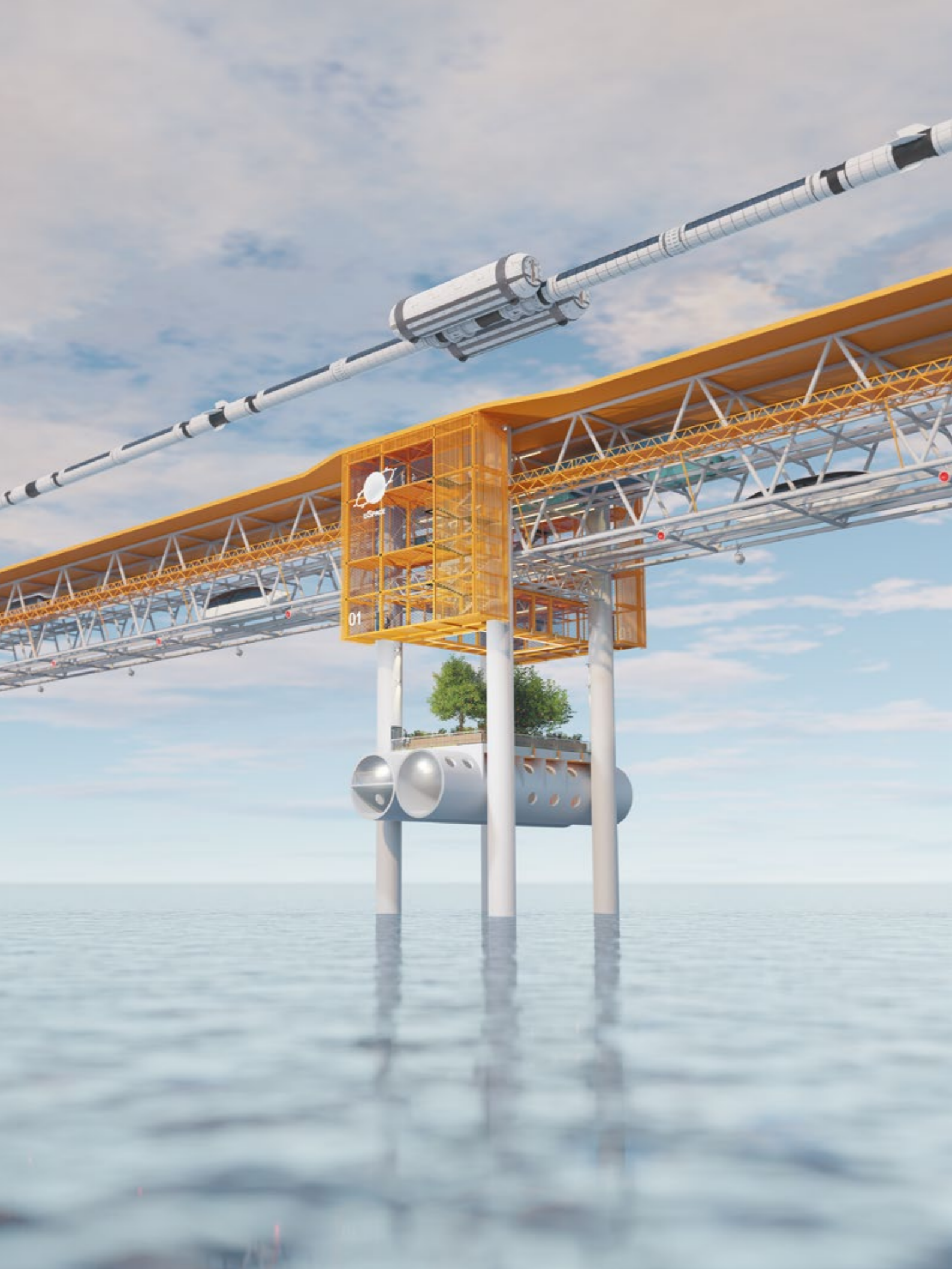

UDC 624.21/.8

General Planetary Vehicle Takeoff and Landing Complex on Oceanic Sections

A. Unitsky
Dr. of Philosophy
in Information Technologies
(Transport)

Astroengineering Technologies LLC,
Minsk, Belarus

Unitsky String Technologies Inc.,
Minsk, Belarus

”

The article conducts research of the highly technical takeoff and landing, transport and infrastructure complex for the giant geocosmic aircraft, namely the General Planetary Vehicle (GPV). Special attention is paid to the evenness of the complex runway, because of the cosmic velocities (about 12 km/s) of the belt flywheels movement, as well as to the maximum reduction of the cost of the unmatched linear structure of 40,076 km, 31,171 km of which will pass through the ocean with an average depth of 4 km. Compliance with the operational safety requirements of the GPV equatorial overpass will make it possible to implement the uSpace geocosmic program at a qualitatively new technological level.

Keywords:

General Planetary Vehicle (GPV), GPV overpass, runway, takeoff and landing complex (TLC).

Introduction

The takeoff and landing complex (TLC) of the General Planetary Vehicle (GPV) passing along the planet's equator must meet a number of complicated technical requirements which allow to ensure safe operation of a giant geocosmic spacecraft with a length of 40,076 km and a mass of about 40 mln tons [1, 2], namely the GPV. These requirements will be especially strict on oceanic sections stretching for 31,171 km, or 77.8 % of the total equator length, equal to 40,076 km. For example, if the ocean depth is more than 100 m, the supports should be floating, since their installation on the bottom will significantly increase the cost of the TLC.

Special attention will be paid to the evenness of the complex runway due to the cosmic velocities of the moving belt flywheels placed in vacuum channels (it is talking about 12 km/s during takeoff and landing of the GPV, which is slightly higher than the second cosmic velocity for Earth, equal to 11.2 km/s).

General Requirements to the GPV Takeoff and Landing Complex

The GPV is designed for geocosmic conditions inherent to the planet's equatorial plane: the gravitational acceleration is 9.87 m/s^2 ; the average starting radius of the GPV (the vertical radius of the runway equal to the equatorial radius of Earth) is 6,378.1 km; the average annual temperature of water and air is $28 \text{ }^\circ\text{C}$.

Changes in the radius of the GPV flywheel belts trajectory lead to an inversely proportional change in centrifugal accelerations and loads on the magnetic (and/or electromagnetic) cushion of linear electric motors. Therefore, when designing a floating load-bearing overpass of the TLC, permissible changes in the radii of its curvature in the vertical and horizontal planes within $\pm 10 \%$ of the radius of Earth, or $\pm 638 \text{ km}$, are accepted. Then, for example, with a linear mass of the GPV of $1,000 \text{ kg/m}$, reducing the radius of the flywheel trajectory to $5,740 \text{ km}$ will lead to an increase in centrifugal force by about 100 kgf/m , or 100 tf/km . An increase in the radius of the flywheel trajectory will respectively cause a similar decrease in the centrifugal force on these GPV sections.

The ocean part of the GPV overpass should not interfere with navigation, including the movement of large ships, the highest of which has a surface height of 72.5 m , the widest has a width of 74 m , and the heaviest has a draft of 24.6 m [3]. Thus, in order to ensure the safe passage of any vessels,

the floating GPV overpass must meet the following requirements (considering that the conditions for vessel passage can deteriorate due to wind and waves):

- the clearance between adjacent supports should be not less than 150 m ;
- the clearance between the water surface and the bottom of the span structure should be not less than 80 m ;
- the underwater elements of the overpass between the supports must be placed at a depth of at least 30 m .

Vessels move along certain routes, therefore, these requirements must be met only within the framework of maritime logistics corridors. There are nine main sea trade routes on the planet – the main arteries of world trade, some of which cross the equator. The passage of fishing vessels and sailboats should be guaranteed on the remaining off-shore sections of the GPV overpass, therefore, the bridge underclearance may have more modest dimensions here, such as width of at least 100 m , height of at least 30 m and depth of placement of underwater linear elements of at least 20 m .

In addition to the GPV takeoff and landing, the equatorial TLC should provide transport, energy and information communications along the Equatorial Linear City (ELC), the main part of which will pass through the ocean [4]. Transport communications along the ELC will be provided by transport and infrastructure complexes of Unitsky String Transport (uST), namely by a high-speed double-track route allowing movement with a speed of up to 600 km/h and a regional (urban) one – with a speed of up to 200 km/h .

This will make it possible to fulfill the planned volume of geocosmic cargo and passenger flows along the "Earth – Orbit – Earth" route: hundreds of millions of tons of cargo and hundreds of millions of passengers per year [5]. Cargo and passengers to be sent into space will be delivered from various places of the planet via the uNet international transport and infrastructure network to certain cargo and passenger modules distributed along the GPV body in increments of about 100 m . Herewith, it is necessary to build optimal geocosmic logistics not only in the forward direction "Earth – Orbit" but also in the opposite direction "Orbit – Earth", when finished goods produced in space will be delivered to Earth for the needs of all humankind – 10 bln people living on all continents of the planet by that time.

GPV Floating Overpass

The floating load-bearing GPV overpass has a span length L_{np} (between the centers of the supports) of $100\text{--}200 \text{ m}$

with a height h_p of the string (prestressed) truss 3 equal to 10 m (Figures 1–3).

The bridge underclearance dimension h_s of the main part of the overpass is 30 m , which will ensure the passage of most ships. For all types of vessels (including the tallest,

widest and those with the largest draft) in the $200\text{--}300 \text{ km}$ wide sea shipping corridors L_{ck} the height of the surface part of the supports 4 has been increased to 90 m , the depth of the horizontal rod 4.7 – up to 30 m , the width of the spans L_{np} has been doubled to $200\text{--}400 \text{ m}$.

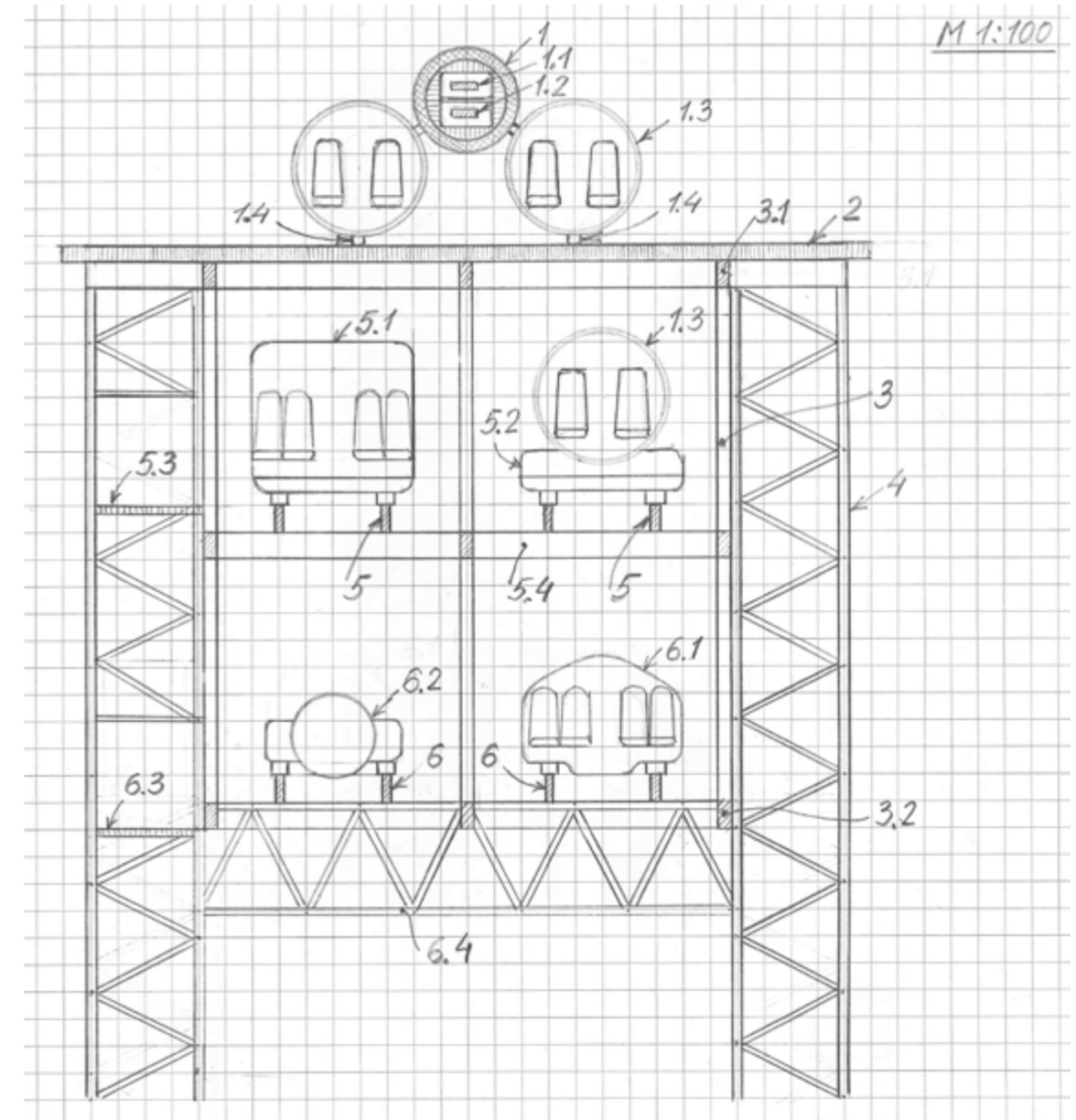

Figure 1 – Cross section of the upper structure of the GPV takeoff and landing overpass:
 1 – GPV body: 1.1 – upper belt flywheel, 1.2 – lower flywheel, 1.3 – cargo and passenger capsule, 1.4 – chassis wheels;
 2 – runway; 3 – load-bearing string truss: 3.1 – upper belt, 3.2 – lower belt; 4 – floating support;
 5 – urban uST (speed up to 200 km/h): 5.1 – urban uPod, 5.2 – cargo uPod, 5.3 – sidewalk;
 6 – high-speed uST (speed up to 600 km/h): 6.1 – passenger high-speed uPod, 6.2 – cargo uPod, 6.3 – sidewalk, 6.4 – support tie bar

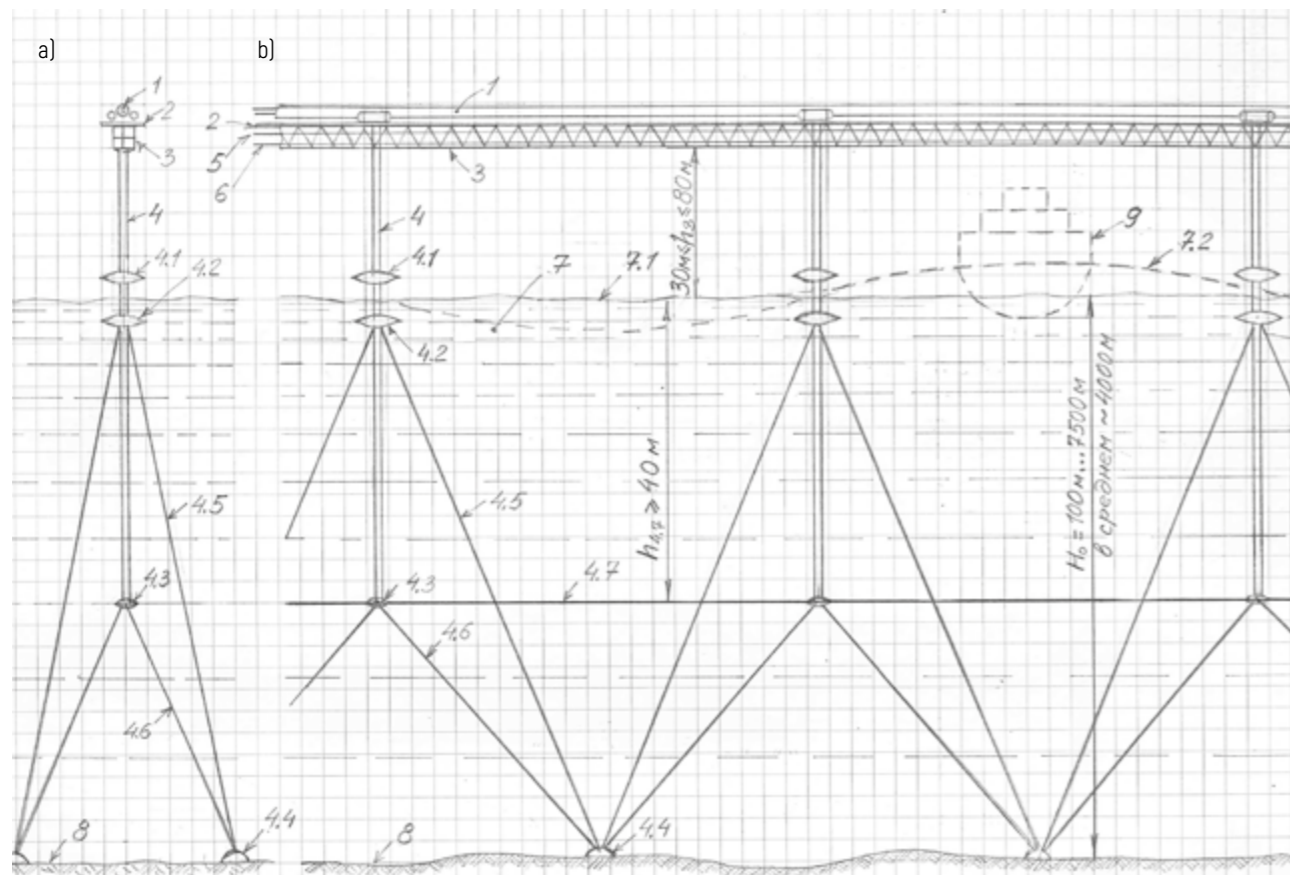

Figure 2 - Diagram of the GPV takeoff and landing overpass on oceanic section (option 1):
 a - cross section; b - side view; 1 - GPV body; 2 - runway; 3 - load-bearing string truss;
 4 - supports: 4.1 - emergency (surface) float, 4.2 - load-bearing (underwater) float,
 4.3 - counterweight (sinker), 4.4 - anchor (sinker), 4.5, 4.6, 4.7 - stabilizing rods (ropes);
 5 - urban uST (speed up to 200 km/h); 6 - high-speed uST (speed up to 600 km/h);
 7 - sea water: 7.1 - sea/ocean surface, 7.2 - wave; 8 - seabed; 9 - ship

Within the maritime shipping corridors, the load-bearing truss 3 is made along a sinusoidal curve with concave and convex vertical curves, the radii of which $R_{\text{вoтн}}$ and $R_{\text{ввпн}}$ differ from the radius of Earth $R_{\text{зем}}$ by no more than 10 % (Figure 4). Therefore, the dynamics of the GPV landing and takeoff on these sections of the oceanic overpass will be more comfortable than on land when crossing mountains, where the height (amplitude) of the vertical sinusoidal curves of the TLC is much higher and their radii of curvature may be much different from the equatorial radius of the planet.

The floating overpass (Figure 3) is anchored to the bottom using a 4.5 and 4.6 rods system having a rigid spatial configuration, which ensure the required stability of the runway during the GPV operation. To ensure their vertical position stability, the supports are equipped with counterweights 4.3

which are streamlined (dish-shaped) to minimize destabilizing forces created by deep currents. The necessary buoyancy of the overpass is provided by floats 4.2, located at a depth of about 5 m (below the minimum level of the sea wave 7.2). They have excessive buoyancy and are held at the desired depth by prestressed (stretched) rods 4.5 and 4.6 attached to anchors 4.4. The floats are streamlined (dish-shaped) to minimize the destabilizing forces created by surface ocean currents.

The GPV overpass (Figure 3) is equipped with emergency floats 4.1 (placed above the water surface 7.1), on which it will descend in case of loss of buoyancy provided by standard floats 4.2. Emergency floats are designed as residential modules and small workshops for maintenance personnel.

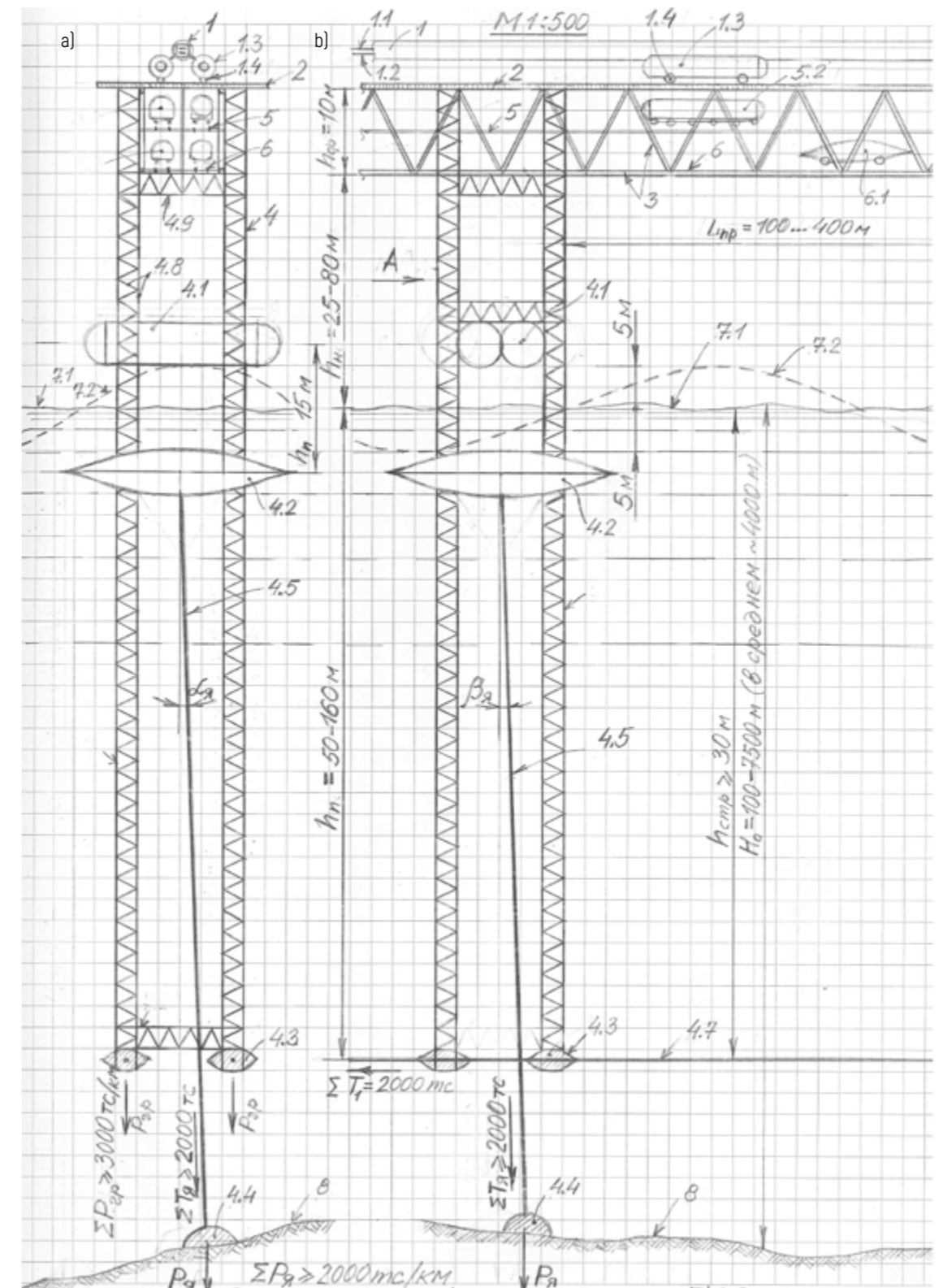

Figure 3 - Diagram of the GPV takeoff and landing overpass on oceanic section (option 2):
 a - cross section; b - side view

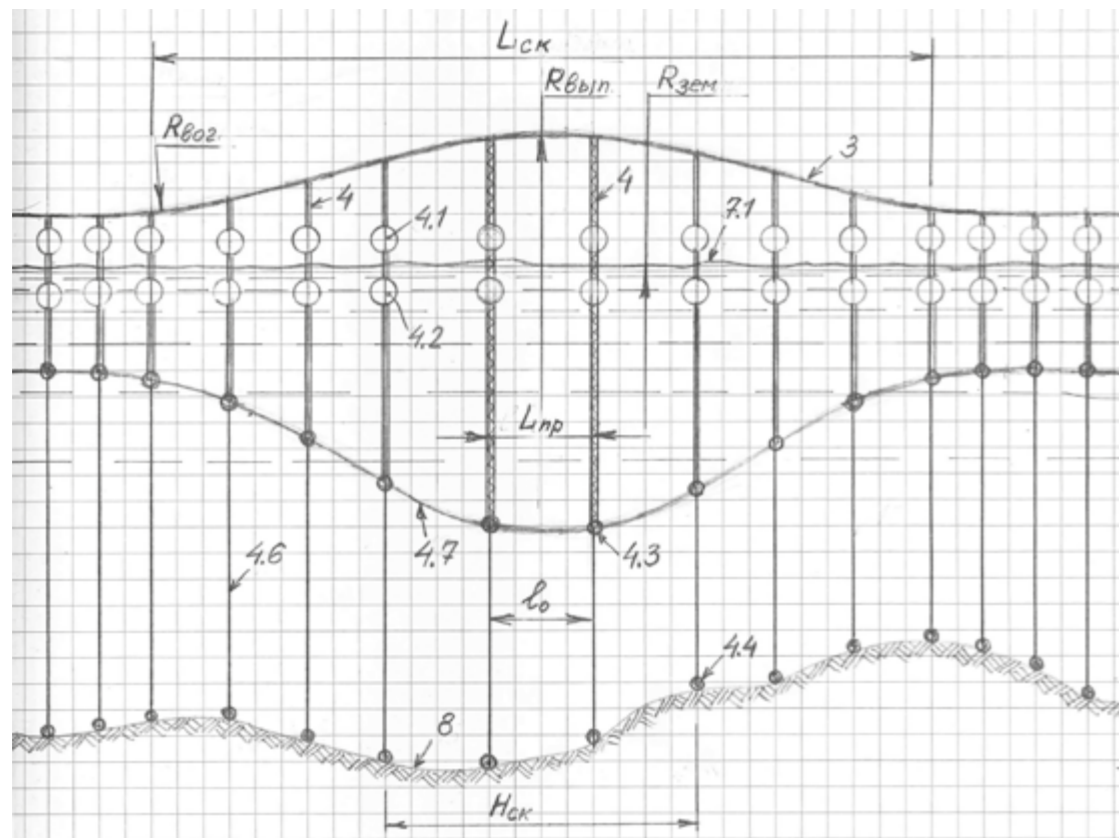

Figure 4 – Diagram of the construction of a shipping corridor with a width of L_{ck} : in the center – for large vessels; at the edges – for smaller vessels

GPV Characteristics

The GPV has a body 1 and belt flywheels 1.1 and 1.2 (Figures 1, 3) located in vacuum channels and equipped with magnetic suspension systems and linear electric motors. Suspended passenger and cargo modules 1.3 are made in pairs, located at an interval of 100–500 m, and their weight is 10–100 tons (the total weight of all modules placed along the entire length of the GPV is up to 10 mln tons).

To take off and land the GPV at a certain horizontal speed, modules 1.3 are equipped with chassis wheels 1.4, which, if necessary, will provide the possibility of landing on runway 2 at speeds up to 250 km/h (heavy aircraft land at about the same speed). In order to maneuver along the height and across the TLC, the GPV is equipped with horizontal and vertical wings (not shown in the Figures). If necessary, this will allow for both landing in airplane mode, when only the wings hold the entire weight of the aircraft, and for a regular landing even in an emergency energy

dynamic situation, i.e., with a complete loss of speed by belt flywheels 1.1 and 1.2, although this cannot be even theoretically (it is impossible to quickly, within the time of one flight, reduce the speed of the flywheels weighing more than 10 mln tons from 12 km/s to zero).

The vertically positioned wings will allow the GPV to carry out a maneuver, namely horizontal movement sideways from the equator at a distance of up to 1,000 km, when landing on Earth. Such a displacement can be plane-parallel or curved along a sinusoidal curve. This will make it possible to place the TLC not strictly along the equator but, for example, parallel to it at a distance of up to 1,000 km. In addition, if, for example, equatorial currents carry the part of the TLC even several kilometers away from the design line, this will not affect the normal functioning of the GPV. A geocosmic aircraft, maneuvering with horizontal and vertical wings, will be able to land on a sinusoidally curved runway 2 (Figures 1–3) if its radii of curvature differ from the radius of Earth by no more than 10 %, as noted above.

The wings can be installed both on the GPV body and on cargo and passenger modules 1.3; they can have additional functionality and be performed as solar panels and, if necessary, used during landing for additional (aerodynamic) damping of the circumferential (around the planet) speed of the GPV body. At the same time, powerful wings of a large area will not be required. To create a horizontal force, for example, of 1 ton per 1 km of the GPV length, or 10 kgf/m (this will allow the GPV to deviate from the equator by 64 km), the total area of the wings should be about 10 m²/km, or 100 cm²/m.

Upper Structure of the GPV Overpass

The load-bearing truss 3 of the overpass (Figure 1) is of a string type and is prestressed in the longitudinal direction. All linear elements of the truss – upper 3.1 and lower 3.2 belts – are stretched longitudinally in such a way that they do not experience compressive forces in the entire standard load range (weight and wind loads, temperature forces, etc.) and are always stretched. The truss is made continuous – it has no temperature seams and joints along its entire length.

To ensure geocosmic logistics and provide the delivery of passengers and cargo to any GPV passenger or cargo module 1.3 when it is on the runway, the overpass has two mounted double-rail cargo and passenger uST complexes (Figure 1). Urban-type uST complexes (travel speed up to 200 km/h) are located on the upper tier of the load-bearing truss 3 of the overpass (string rail track structure 5); intercity-type uST complexes (travel speed up to 600 km/h) are located on the lower tier (string rail track structure 6).

uST track structures are designed for a mobile load weighing up to 50 tons, which will allow transporting geocosmic modules 1.3 with passengers and cargo pre-placed in them to the GPV location. Passenger stations (stopping points) and cargo terminals (cargo platforms) of the urban uST are concentrated every kilometer on average, while for the high-speed uST the figure is each 50–100 km.

To maintain uST complexes there are sidewalks 5.3 and 6.3 which can also be used for movement of compact machines along a separate narrow-gauge rail track.

Forces Affected on the GPV Floating Overpass

The average depth of the Pacific, Indian and Atlantic Oceans along the equator is about 4 km, while the maximum

depth is just over 6 km [6]. The floating GPV overpass on oceanic sections (Figures 1–4) will be affected by vertical and horizontal static and dynamic forces, whose action will be discussed in more detail below.

Vertical forces

For the surface part of the overpass:

1) the own weight of the surface part of the overpass, including runway 2, urban 5 and high-speed 6 uST track structures, emergency (spare) pontoons 4.1 and the surface part of the supports 4: total about 4,000 tf/km (4 tf/m);

2) the GPV weight:

- during commissioning (with motionless belt flywheels): 1,000 tf/km (1 tf/m);
- during loading and unloading operations before lifting the GPV into orbit and after descent to Earth: –250 tf/km (payload weight; the minus sign means that the excess centrifugal force of the GPV belt flywheels will be directed upwards when the payload is removed);
- the weight of the uST rolling stock (urban 5.1 and 5.2 and high-speed 6.1 and 6.2): about 500 tf/km (0.5 tf/m).

For the underwater part of the overpass (taking into account the buoyancy forces):

1) the net weight of the underwater part of the overpass, including the weight of the underwater part of the supports 4, load-bearing floats 4.2, rods 4.7, stays 4.5 and 4.6, etc.: total about 3,000 tf/km (3 tf/m);

2) the weight of sinkers 4.3 at the bottom of floating supports 4: about 3,000 tf/km (3 tf/m);

3) forces in rods 4.5 and 4.6 of anchors 4.4 installed on the ocean floor (the average thrust length of rods is 4,000 m and is equal to the average depth of the ocean): 2,000 tf/km (2 tf/m);

4) the buoyance force acting on all underwater elements of the overpass and directed upwards, primarily on the load-bearing floats 4.2 (the average value is 1.025 tf/m³): 12,500 tf/km (12.5 tf/m).

Horizontal forces

Transverse forces:

1) in the surface part of the overpass – transverse equatorial wind;

2) in the underwater part of the overpass – transverse equatorial currents.

Longitudinal forces:

1) in the surface part of the overpass:

- internal forces – the pretensioning forces of the longitudinal elements of the surface part of the overpass (belts 3.1 and 3.2) of the load-bearing string trusses 3, string rails of the uST transport and infrastructure complexes 5 and 6 and the braking (acceleration) forces of the uST rolling stock: about 5,000 tf;

- external forces – longitudinal equatorial wind;

2) in the underwater part of the overpass:

- internal forces – the pretensioning forces of the longitudinal elements of the underwater part of the overpass (prestressed rods 4.7 connecting the bottom of the floating supports with each other to stabilize their linear position): about 1,000 tf;

- external forces – the undercurrent along the overpass.

The greatest danger to the overpass is represented by external transverse forces that will seek to shift it sideways from the equator line, bend this structure horizontally and overturn it.

The equator is usually calm. This is a special region where wind is very rare. Trade winds move from the equator, but there is practically no wind at the equator itself.

A powerful transfer of waters from the western parts of the oceans to the eastern ones has been detected in the equatorial zone. Such a phenomenon, like the surface equatorial return current, is considered compensatory and occurs in the subsurface layer exactly below the equator (Cromwell Current in the Pacific Ocean, Lomonosov Current in the Atlantic as well as subsurface and partially surface currents to the left and right of these currents). For example, the Cromwell Current has a thickness of about 200 m and a width of 300 km, moves at a speed of up to 1.5 m/s and runs at a depth of 100–400 m, rising to a level of 50 m. The maximum velocities of surface currents at the equator are approximately 0.25 m/s.

Thus, the circulation of waters in the upper layers at low latitudes includes:

- trade (equatorial) currents;

- system of surface and subsurface equatorial return currents;

- powerful stock warm currents at the western edges of the ocean and compensatory cold currents from higher latitudes at the eastern edges (with warm return currents);

- immersion of waters near the tropics and in some areas of the equatorial band, especially at the western edges of the ocean;

- the rise of waters in two zones of divergence near the equator, in vast areas near the eastern edges of the oceans and in places in the west.

To reduce external transverse forces, the load-bearing floats 4.2 and sinkers 4.3 are streamlined, disk-shaped, and have a coefficient of resistance (aero- or hydrodynamic) $C_x = 0.05$ (for comparison: for a cylinder, i.e., for a pipe, rod or rope, $C_x = 1$, or 20 times more).

The specific wind forces (in terms of 1 m² of the mid-section, i.e., the cross section of the structural element) affecting the surface elements of the TLC structure at a wind speed of 30 m/s (108 km/h) will be as following:

1) for highly aerodynamic elements with $C_x = 0.05$: 2,9 kgf/m²;

2) for non-aerodynamic elements with $C_x = 1$ (cylinder shape): 58 kgf/m².

Forces affecting the underwater structural elements of the runway overpass:

1) for highly streamlined elements with $C_x = 0.05$:

- 0,16 kgf/m² for a flow rate of 0.25 m/s;

- 5,7 kgf/m² for a flow rate of 1.5 m/s;

2) for the elements with $C_x = 1$ (cylinder shape):

- 3.2 kgf/m² for a flow rate of 0.25 m/s;

- 110 kgf/m² for a flow rate of 1.5 m/s.

Calculation of the GPV Takeoff and Landing Complex Cost

To calculate the cost of the TLC, the following initial cost characteristics were taken (in weighted average world prices at the beginning of 2023):

- rolled steel (high-strength steel wire, reinforcing ropes, tape, strip, channel, I-beam, etc.): 2,500 USD/t;

- rolled steel building structures (floating supports, load-bearing structures, etc.): 6,000 USD/t;

- complex structural elements, assemblies, aggregates: 12,000 USD/t;

- installation of structures: 2,500 USD/t.

Tables 1–3 show the consumption and average cost of materials as well as the cost of construction for the above-mentioned parameters of the oceanic part of the TLC, including transport, residential and industrial infrastructure.

The specific cost of the floating GPV takeoff and landing overpass on oceanic sections (Table 1) is 21 mIn USD/km.

Table 1 – Average consumption of materials and estimated cost of the floating GPV takeoff and landing overpass on oceanic sections (average span length – 180 m, average height of the surface part – 50 m, average ocean depth – 4,000 m)

Overpass element	Quantity per 1 km of the floating overpass length	Cost of one mounted unit of measurement*, USD	Total cost of 1 km of the overpass, USD
Load-bearing string truss	1,100 tons	4,000	4,400,000
Floating supports, total			6,900,000
Including:			
• load-bearing columns	500 tons	3,000	1,500,000
• main (underwater) load-bearing pontoons	12,000 m ³	200	2,400,000
• emergency (surface) pontoons	12,000 m ³	200	2,400,000
• support counterweights	2,000 tons	300	600,000
Anchoring system, total			3,100,000
Including:			
• sinkers (bottom)	2,000 tons	300	600,000
• vertical rods (average rod length is 4,000 m)	800 tons	2,500	2,000,000
• horizontal rods (strings connecting the bottom of the floating supports to each other)	200 tons	2,500	500,000
GPV runway	15,000 m ²	300	4,500,000
Other	–	–	2,100,000
Total			21,000,000

Table 2 – Estimated cost of the uNet transport and infrastructure network combined on oceanic sections with the GPV floating takeoff and landing overpass

uNet element	Quantity per 1 km of the floating overpass length	Cost of one mounted unit of measurement*, USD	Total cost of 1 km of the overpass, USD
Track structure of the double-track rapid (up to 200 km/h) cargo and passenger uST complex	1 km	2,500,000	2,500,000
Track structure of the double-track high-speed (up to 600 km/h) cargo and passenger uST complex	1 km	3,000,000	3,000,000
Logistics units and their elements (passenger stops, stations, cargo terminals, pedestrian pathways, sidewalks, etc.)	1 km	2,000,000	2,000,000
Automatic control, power supply and communication systems	–	–	2,500,000
Rolling stock (passenger, cargo, both passenger and cargo rapid and high-speed uPods)	–	–	3,000,000
Other	–	–	1,500,000
Total			14,500,000

* Based on the global average prices for similar infrastructure solutions at the beginning of 2023.

Table 3 – Estimated cost of residential and industrial infrastructure combined on oceanic sections with the uNet transport and infrastructure network and the floating GPV takeoff and landing overpass

Infrastructure element	Quantity per 1 km of the floating overpass length	Cost of one mounted unit of measurement*, USD	Total cost of 1 km of the overpass, USD
Infrastructure combined with the uNet transport and infrastructure network (stations, terminals, control rooms, other buildings and structures)	2,000 m ²	1,500	3,000,000
Infrastructure combined with the floating overpass (surface and underwater pontoons, other facilities)	1,000 m ²	1,500	1,500,000
Other	500 m ²	1,000	500,000
Total			5,000,000

* Based on the global average prices for similar infrastructure solutions at the beginning of 2023.

The specific cost of the uNet transport and infrastructure network, combined on oceanic sections with the floating GPV takeoff and landing overpass (Table 2), is 14.5 mln USD/km.

The specific cost of residential and industrial infrastructure combined on oceanic sections with the uNet transport and infrastructure network and the floating GPV takeoff and landing overpass (Table 3), is 5 mln USD/km.

The total specific cost of oceanic sections of the GPV TLC is 40.5 mln USD/km.

Conclusion

At the international scientific and technical conferences "Non-Rocket Near Space Industrialization: Problems, Ideas, Projects", held in 1988 and in 2019–2022, various designs and technologies for the construction of the GPV takeoff and landing overpass were considered [2, 4, 7, 8]. However, these proposals were not complex in approaches as well as were material-intensive and had a high cost. The constructive and technological solutions presented in this study will reduce the cost of the GPV TLC combined with the uST string rail roads and infrastructure elements of the ELC by at least 2 tln USD. After optimization, this most difficult overpass-type complex turned out to be, for example, twice as cheap as a much simpler project – the ground Palm Jumeirah Monorail [9], the cost of which amounted to 73 mln USD/km in 2008 prices (over 100 mln USD/km in 2023 prices).

The proposed solutions can be used not only for oceanic sections of the GPV overpass but also on land as well as when creating overpass-type transport and infrastructure corridors in linear cities (uCities), including the ELC.

References

1. *Unitsky, A. String Transport Systems: On Earth and in Space / A. Unitsky. – Silakrogs: PNB Print, 2019. – 560 p.*
2. *Non-Rocket Near Space Industrialization: Problems, Ideas, Projects: Collection of Articles of the V International Scientific and Technical Conference, Maryina Gorka, Sep. 23–24, 2022 / Astroengineering Technologies LLC, Unitsky String Technologies Inc.; ed. A. Unitsky. – Minsk: StroyMediaProject, 2023. – 320 p.*
3. *Samyye bol'shiye korabli v mire [The Largest Ships in the World] [Electronic resource]. – Mode of access: <https://clck.ru/37D73F>. – Date of access: 12.04.2023.*
4. *Non-Rocket Near Space Industrialization: Problems, Ideas, Projects: Collection of Articles of the IV International Scientific and Technical Conference, Maryina Gorka, Sep. 18, 2021 / Astroengineering Technologies LLC, Unitsky String Technologies Inc.; ed. A. Unitsky. – Minsk: StroyMediaProject, 2022. – 384 p.*
5. *Unitsky, A.E. Tsvivilzatsionnaya yomkost' kosmicheskogo doma po imeni Planeta Zemlya [Civilization Capacity of the Space Home Named Planet Earth] / Anatoli Unitsky. – Minsk, 2021. – 148 p.*
6. *Profil' dna Mirovogo okeana po ekvatoru [Bottom Profile of the World Ocean Along the Equator] [Electronic resource]. – Mode of access: <https://ru-ecology.info/pics/203644800440022/>. – Date of access: 15.03.2023.*
7. *Non-Rocket Space Industrialization: Problems, Ideas, Projects: Collection of Articles of the II International Scientific and Technical Conference, Maryina Gorka, Jun. 21, 2019 /*

Astroengineering Technologies LLC; ed. A. Unitsky. – Minsk: Paradox, 2019. – 240 p.

8. *Bezraketnaya industrializatsiya blizhnego kosmosa: problemy, idei, projekty [Non-Rocket Near Space Industrialization: Problems, Ideas, Projects]: Collection of Articles of the III International Scientific and Technical Conference,*

Maryina Gorka, Sep. 12, 2020 / Astroengineering Technologies LLC, Unitsky String Technologies Inc.; ed. A.E. Unitsky. – Minsk: StroyMediaProject, 2021. – 516 p.

9. *Palm Jumeirah Monorail [Electronic resource]. – Mode of access: https://en.wikipedia.org/wiki/Palm_Jumeirah_Monorail. – Date of access: 21.05.2023.*

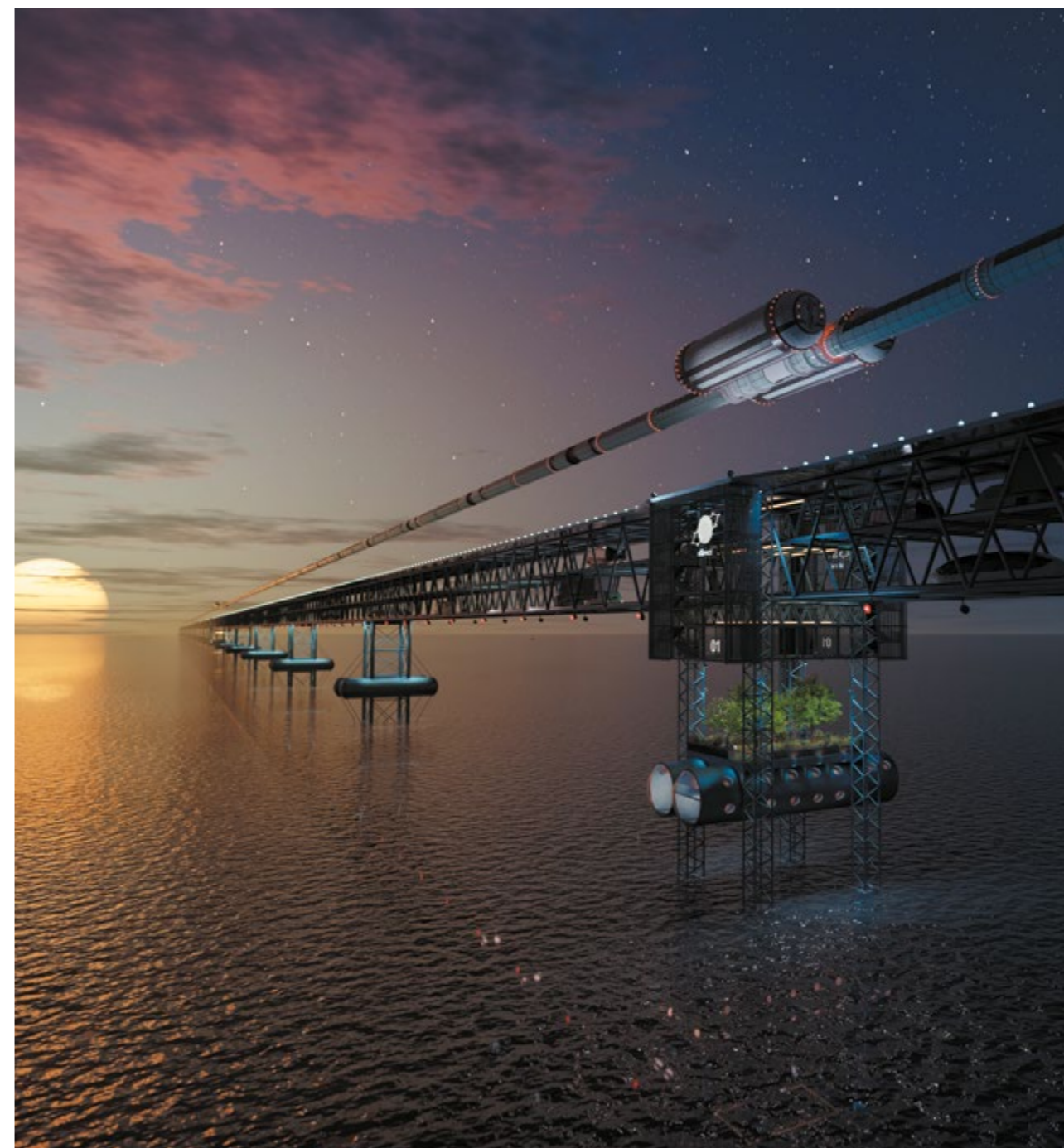

Technology and Mechanization of Construction Process at Land Sections of the General Planetary Vehicle Equatorial Overpass

A. Unitsky^{1,2}
Dr. of Philosophy
in Information Technologies
(Transport)

D. Bochkaryov^{2,3}
Ph.D. in Engineering Sciences

¹ Astroengineering Technologies LLC,
Minsk, Belarus

² Unitsky String Technologies Inc.,
Minsk, Belarus

³ Belarusian State University
of Transport,
Gomel, Belarus



The article reviews technological processes regarding construction of the supports and span structures at land sections of the General Planetary Vehicle (GPV) takeoff and landing overpass. There is justification of advantages and disadvantages of the common and alternative construction technologies. The authors offer technical means and design solutions aimed to reduce the erection period and increase the quality of construction of this extended and important structure which is the GPV overpass.

Keywords:

concreting, formwork, General Planetary Vehicle (GPV), GPV overpass, rope, span structure, support.

Introduction

The equatorial takeoff and landing overpass of the General Planetary Vehicle (GPV) is a global logistics and infrastructure facility that contains passenger stations, cargo terminals, logistics centers as well as rapid, high-speed and hypervelocity complexes of Unitsky String Transport (uST) for multimodal cargo and passenger transportation. The overpass covers Earth in the equatorial plane and has a length of 40,076 km, of which 31,171 km are in water sections and 8,905 km are in land sections [1]. The enormous scale of the GPV takeoff and landing overpass places extremely serious demands on the organization, technology and mechanization of its construction, which must rationally combine high productivity, unconditional quality of work and minimization of material costs for the effective operation of this complex engineering facility at all stages of its life cycle.

There will be a total of 29,684 supports with an average pitch of 300 m for land sections in the GPV overpass. Based on the need to ensure a longitudinal profile of the overpass with the maximum possible radii of vertical and transitional curves to minimize parasitic centrifugal forces that affect the GPV and to replicate the large relief of the earth's surface in order to reduce the volume of excavation work, the average height of the supports can reach 300 m [2] and in some cases significantly exceed this value, for example, when crossing the Andes.

World practice shows the feasibility of such structures: the tallest building was built in 2010 in the UAE – the Burj Khalifa Tower (828 m). A suspension bridge connecting the provinces of Guizhou and Yunnan (China) was erected in 2016 across the river Beipanjiang; its length is 1,341.4 m, the height of the roadway above the water level is 564 m.

Design of the GPV Equatorial Overpass

In order to choose the correct GPV overpass design, it is necessary to consider all functions it performs and develop the required structural elements in accordance with them, including the interaction with the GPV directly, especially during its takeoff and landing. According to research [1], the GPV consists of an outer shell, on which equipment and payload are attached, and internal linear (belt) rotors placed in vacuum channels and accelerated by an electromagnetic field to a speed of 12 km/s. When the rotor spins around the planet, a centrifugal force arises, which is lifting and exceeds the force of gravity making it possible to move the GPV into orbit. Thus, the load from the GPV varies

from 1,000 to 0 kg per linear meter of the overpass during takeoff and from 0 to 1,000 kg during landing. This should be considered when developing and calculating the overpass for strength and durability.

The selection of span structure type determines the bearing capacity of the overpass as well as the manufacturability of its construction and cost. Beam span structures are the most widespread, while cable and suspension bridges can provide the optimal span. The main distinctive feature of the beam system: only vertical loads are transferred from the span structures to the supports, and there are no horizontal ones. Beam structures can be split, consisting of a number of beams, each of which covers one span. This system is statically determinate and can be used on any type of foundation but requires a large number of expansion joints and the mandatory presence of two supporting parts on each supporting tower. In a continuous system, one beam of the span structure overlaps several spans or all at once; the span structure is calculated as a multi-support statically indeterminate beam using the force method, the displacement method or other methods for calculating statically indeterminate systems involved in structural mechanics. The continuous system is characterized by the absence of expansion joints but is sensitive to base deformations and thermal forces due to the maximum range of temperature fluctuations over the entire service life.

Suspension (cable) bridges, compared to bridges made using a beam design, imply an increased height of the supports (pylons), their location on both sides of the span structure as well as a system of ropes (cables) supporting it. However, pylons towering above the span structure can hamper the GPV to take off and land, requiring it to be maneuvered with extremely high precision so that there is no contact between the GPV body, the pylons and the rope system. At the same time, the main stresses in a suspension bridge are tensile stresses in the ropes (cables) and compressive stresses in the supports. The stresses in the span itself are low. Almost all forces in the supports are directed vertically downwards and are stabilized by the ropes. In the above bridge designs, the span structures can be made both in the form of solid beams of various sections and in the form of lattice structures, i.e., trusses.

Analysis and Selection of Building Materials

In modern construction, steel and concrete are most widely used as the main structural materials. The advantages of using steel include a significantly better performance under tensile loads. In addition, steel structures are characterized

by low material consumption. However, this alloy is much more expensive, is susceptible to corrosion and has low fire resistance. The increase of the corrosion properties of steel is possible through protective coatings and alloying, which further increases its cost. Concrete works well under compression, has a high degree of fire resistance and is low in cost. At the same time, concrete structures have considerable dead weight. Based on the listed main advantages and disadvantages, steel and concrete divided the forces between themselves in building structures: concrete took on the compressive forces, and steel took on the tensile forces, which is widely implemented in reinforced concrete structures, especially prestressed ones [3].

The development of this direction, which makes it possible to combine the advantages of these materials and eliminate their disadvantages even more fully, is possible in steel-reinforced concrete structures. They use the principle of integrated work of metal elements with reinforced concrete, which distributes internal forces between the corresponding parts of the sections, improving their design characteristics. Thanks to this, the total metal consumption is reduced as well as the section sizes and construction height of the floors, and the bearing capacity and rigidity of the structure are increased. In addition, steel-reinforced concrete structures are fire resistant, since concrete has a high specific heat capacity. Accordingly, the steel element is protected from overheating and its bearing capacity is not decreased. An increase in the bearing capacity of these structures can be considered using the example of reinforced concrete and steel-reinforced concrete columns with a diameter of 60 cm. The bearing capacity of a four-meter reinforced concrete column is about 6,000 kN, while a steel-reinforced concrete column has a bearing capacity of up to 32,000 kN, i.e., 5.33 times more [4]. If steel and steel-reinforced concrete decks are compared, the steel savings with the same load perception in the case of a steel-reinforced concrete structure will be about 15 % [5]. Such structures have become widespread in the construction of bridges. In particular, corrugated walls are used in more than 50 bridges in Japan.

Based on the above, the volume of required concrete is calculated and it is equal to 16 m³. This is the amount needed to erect 1 lin m of span structure of the GPV overpass with cross-sectional dimensions that ensure independent movement inside the overpass of four types of vehicles. And the vehicles in their turn have the ability to transport cargo in 20-foot (Dry Cube) and 40-foot (High Cube) containers. In this case, the mass of 1 lin m of overpass will be about 40 tons. Consequently, for the construction of its land sections

with a length of 8,905 km, 142.5 mln m³ of concrete will be needed. Considering that 1 m³ of M500 concrete contains 313 kg of cement, 44.6 mln tons of cement are needed for their construction. Due to this load as well as the load from the GPV, the diameter of the supports is determined, which for a steel-reinforced concrete design can be equal to 3 m, while for the construction of one average 300-meter support will require 2,119.5 m³ of concrete, and for 29,684 supports for the GPV overpass with a span of 300 m – 63 mln m³ of concrete, or 19.7 mln tons of cement. Thus, the total volume of concrete intended to create the monolithic GPV overpass is 205.5 mln m³, which is equivalent to 64.3 mln tons of cement.

According to the World Cement Association [6], the global cement industry currently employs 1.2 mln people, and the annual production capacity of industry enterprises is 6.5 bln tons. The highest cement consumption – 4 bln tons – was recorded in 2014 and since then has remained approximately at the same level. This means that global industry makes it possible to ensure the production of the required amount of cement for the construction of such a large-scale structure as the GPV overpass, which is only 1 % of its total capacity. Consequently, there will be no harm to consumers of these products in other areas of the global construction industry.

Analysis of Technological Processes for Constructing Supports

The technological processes of erecting the supports of the GPV overpass are generally traditional and include the installation of foundations, the basis of which is the plunging of various types of piles (driven, bored), and the construction of the supports' body by means of concreting in formwork.

Nowadays, in the world practice of creating bridge structures that can withstand heavy loads, bored piles are widely used. They are constructed by drilling wells in the ground and then filling them with reinforced concrete. The main advantages of such piles: the ability to use on all types of soil (especially rocky and seismically unstable), the absence of dynamic impact on the soil and foundations of nearby structures and high bearing capacity.

Based on the nature of the work in the ground, bored piles are divided into standing piles and hanging piles, each of which, depending on the hydrogeological conditions of construction, can be used in the erection of supports for the GPV overpass. Standing piles include piles resting on practically incompressible soils (rock, coarse rocks with sand filler, etc.). Such piles transfer the load to the ground through the heel (soil resistance along the side surface of the shaft

is not considered in calculations of their bearing capacity). Hanging piles, buried in compressible soils, perceive the load through the side surface and the heel.

When installing bored piles, various technologies are used [7]: continuous auger drilling, drilling with the walls of wells protected from collapse by filling them with a special clay solution, drilling wells under the protection of inventory casing pipes or drilled steel pipes, followed by their reinforcement and filling with concrete.

To determine the continuity of bored piles, it is necessary to use ultrasonic, acoustic and other nondestructive testing methods, which make it possible to detect defects in the form of breaks and inhomogeneities measuring up to 10 % of the diameter. Also, it allows to identify the actual position of the base of the piles.

In parallel constant monitoring of the following parameters is required: the mobility of the concrete mixture, the intensity of placement, the levels of the concrete mixture in the concrete pipe and well, the levels of the lower ends of the concrete pipe and casing pipes in order to maintain their minimum penetration into the concrete, as well as the strength of the concrete laid in the well.

As an alternative to the types of piles discussed above, it is possible to use vibro-submersible precast reinforced concrete shells, which are filled with monolithic concrete or reinforced concrete [7].

In addition, foundations on drop wells made of monolithic or prefabricated reinforced concrete or concrete as well as steel are used if solid soil lies at a relatively shallow depth. However, shallow foundations are too expensive, and pile foundations are impractical due to the insufficient depth of pile driving [7]. Drop wells are also applied under heavy loads, in difficult conditions of sea straits and in all cases at a depth of up to 70 m.

Before proceeding with the construction of the support body, the work on installing the foundation and concreting its grillage must be completed and accepted [7]. In this case, the reinforcement of the piles, released from their heads, is embedded in the grillage slab, and the grillage reinforcement – in the support body, the construction of which can be most effectively implemented using sliding formwork characterized in constant movement upwards at a given pace as far as high-rise structures are concreted. Currently, sliding formworks of various types have been created, which are a spatial formwork shape installed along the perimeter of the structure being built and lifted by hydraulic cylinders (jacks) [8] as far as it is being concreted through continuous supply and laying of the concrete mixture by gravity or pressure (top-rising or bottom-rising flow) methods [9]

as well as using the falling concrete method [10]. This technological process includes installation of reinforcement, constant monitoring of the verticality of the object being built, the position of the formwork, the quality of concrete, installation of embedded parts and operational management.

The listed works are carried out at a pace corresponding to the specified speed of raising the formwork, which is determined by the conditions of concrete hardening at a given outside temperature and mixture composition and also serves as a criterion for organizing the entire technological process. When lifting the formwork at a speed less than optimal, the solidity of the structure decreases, the adhesion forces of concrete to the formwork increase, which complicates the process itself. The concrete failures and other defects occur that impair the quality. For this reason, stopping the formwork is undesirable in order to avoid the concrete from setting on the panels. Experience in operating sliding formworks shows that the lifting speed should be 15–30 cm/h in increments of 2.5–3 cm with each lift. If all requirements are met, the productivity of the construction of the facility is on average 3–6 m/day.

At the same time, the disadvantages of the sliding formwork technology are possible concrete failures (when the formwork is lifted, it carries with it some of the weak material); through or non-through horizontal cracks, horizontal sagging of concrete; cavities and leaks on the surface, which are formed as a result of noncompliance with technological parameters that determine the kinetics of concrete strength gain; scuffing, chipping, roughness of concrete walls as a result of lack of control over the cleanliness of the formwork surface and geometric deviations of the system. In the event of a forced break in concreting, measures should be taken to prevent the adhesion of the laid concrete to the formwork: the formwork is slowly raised until a visible gap is formed between it and the concrete, or it is periodically raised and lowered within the limits of the stroke of the hydraulic cylinder rod (step in place). When concreting is resumed, it is necessary to clean the formwork, remove the cement film from the concrete surface and moisten the surface. After concreting is completed, the sliding formwork at a high altitude of the structure is removed from above by a cargo helicopter [7].

Overcoming the noted disadvantages is possible through the use of complex additives [9], which make it possible to obtain hightech concrete mixtures. They can be of various grades of increased mobility with a cone sediment of up to 28 cm without increasing cement consumption (Figure 1). This means that it is advisable to use cast concrete not only for thin-walled structures but also for massive blocks.

From the presented graphs it is clear that when testing the additives separately, they had a plasticizing effect

on the concrete mixture with a cone sediment of 4 cm, but the effect was of varying degrees: the efficiency of both additives was higher with increasing cement consumption. With a cement consumption of 340 kg/m³ and 0.8 % additive of C-3 grade, the cone sediment increased from 4 to 22 cm. Wood chemical additive (WCA), introduced to the same initial mixture in an amount of 0.1%, provided the cone sediment to 8.5 cm.

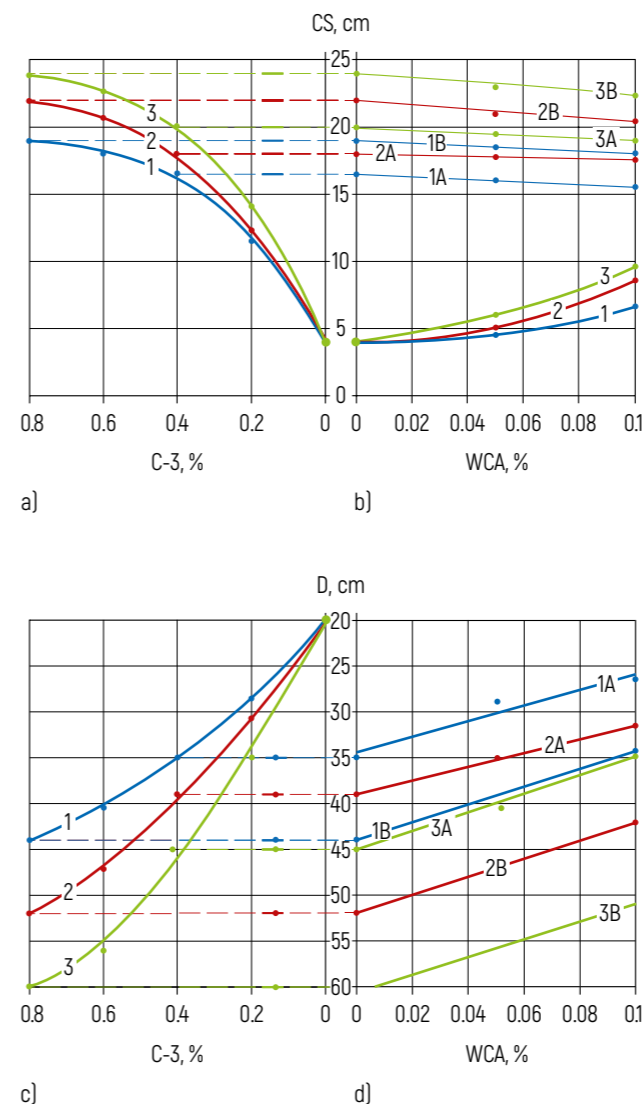

Figure 1 – Effect of the content of superplasticizer C-3 in combination with the air-entraining WCA on the change in: a, b – cone sediment (CS); c, d – diameter of the cone spread (D) [9]; 1, 2, 3 – concrete mixture with cement consumption of 280, 340, 400 kg/m³ respectively; 1A, 2A, 3A – concrete mixture with cement consumption of 280, 340, 400 kg/m³ and the addition of 0.4 % C-3 + WCA; 1B, 2B, 3B – concrete mixture with cement consumption of 280, 340, 400 kg/m³ and the addition of 0.8 % C-3 + WCA

When using WCA together with the C-3 additive, the mobility of the concrete mixture decreased. Herewith, the method of assessing mobility by cone sediment turned out to be less sensitive to the influence of the WCA: the cone sediment changed slightly – by 0.5–1.5 cm, which is equal to 5–6 %.

A more sensitive method is to measure the cone spread. With the introduction of 0.1 % WCA, the diameter of the cone spread decreases by an average of 18–22 %. Regardless of the content, the combination of additives of C-3 and WCA grades in relation to the plasticization of the concrete mixture turned out to be negative. At the same time, WCA contributed to significant air entrainment as well as a decrease in water separation and solution separation of the concrete mixture. Thus, cast mixtures are practically close to self-compacting, which means that some of the compositions can be used in this capacity as more resource-saving and economical.

Analysis of Technological Processes for Construction of Span Structures

Two options can be chosen from the existing variety of modern structures of reinforced concrete bridge spans and their corresponding technological construction processes with regard to the GPV equatorial overpass and the conditions of its construction:

- prefabricated prestressed structure from standard box-section elements;
- monolithic continuous prestressed structure [7].

The elements of a prefabricated structure overpass must be manufactured in advance at factories for reinforced concrete products, mobile production facilities or on-site testing ground, which will ensure the necessary mass production, the stability of geometric dimensions, the physical and mechanical properties of materials and the quality characteristics of finished products. The blocks that have passed quality control are transported to overpass construction sites being evenly distributed along the equator, which requires the construction of long technological roads, a large number of heavy vehicles and the organization of their movement. Next, using various means of mechanization (installation cantilever cranes, cantilever-sluice type crane units, etc.), the elements of the overpass are installed in the design position, first in the overhead sections and then in the span sections with the installation of assembly adhesive joints and tension of the working reinforcement bundles [7].

The advantage of prefabricated span structures lies in the possibility of simultaneous installation on various sections of the overpass evenly distributed along the equator, which helps to reduce the construction time of the entire structure. However, the disadvantage of this design is the presence of a large number of assembly joints between elements (blocks) that reduce the overall reliability of the overpass.

Monolithic span structures are erected directly on the site using formwork. During their construction, heavy-duty cranes and special vehicles for transporting heavy and large-sized elements are not required, while the number of expansion joints is minimal, which is important for increasing the durability of the structure. The monolithic method also makes it possible to simultaneously build on various sections of the overpass evenly distributed along the equator. This approach helps to reduce the construction time of the entire structure but implies a constant continuous supply of distributed objects with materials: crushed stone, sand, cement, etc.

From the point of view of operational reliability, the advantage of monolithic structures over prefabricated ones, apart from the absence of joints, is also that the non-stressed reinforcement of the previous section is not interrupted but is joined to the reinforcement of the subsequent section.

In continuous beam and frame span structures, the tension of the upper beams is carried out as concreting proceeds; the lower beams are tensioned after the span structure is closed and converted from a cantilever system to a continuous beam system.

The suspended concreting method, which is most suitable for the construction of the GPV equatorial overpass, consists in the consecutive sectional concreting of its span structure in the direction from the supports to the middle of the spans. Sections of the 3–5 m long span structure are concreted in formwork that can be permanent, performing the functions of both protection from the external environment and thermal insulation (this contributes to better hardening of concrete in the equatorial climate zone), as well as sliding, which is part of special units installed and moved along a previously concreted part of the span structure. With a shorter concreting length, the number of sections and the duration increase. The sections of considerable length are undesirable due to the weight of the overpass cantilevers and mobile units. The maximum size of a reinforced concrete cantilever concreted using the suspended method is limited by the strength of the section at its root and the stability of the span structure against overturning. At the same time, the use of permanent formwork, in contrast to sliding one, is less productive due to the high complexity of preliminary installation.

Depending on the design of the span structure, the size of the spans and their ratio, various options for suspended concreting are possible, the main ones being balanced and semi-balanced, carried out simultaneously by two units. With their help, the cantilevers of the span structure are extended in both directions from the support, ensuring joint stability [7].

Based on the monolithic nature of the spans of the GPV overpass, special devices are required for their construction.

Units for suspended concreting of the traditional type can have different designs (cantilever, frame, solid wall, through, etc.) and move along the concreted part along rail tracks on carts [7]. Transverse beams are suspended from the cantilever part of the unit, on which the working flooring is laid. The length of the suspended platform must be sufficient to accommodate the section being concreted and the reinforcement protruding from it. The stability of the unit position can be achieved by installing a counterweight (when moving) and anchoring it to the structure of a concrete span. The position of the scaffolding during concreting to ensure the design lines is adjusted by jacks. The disadvantages of a cantilever unit of a traditional design are the cyclical nature of concreting operations as well as a large number of technological processes and structural elements that complicate assembly operations and increase metal consumption.

Development of the Design of a Device for Continuous Concreting of the GPV Overpass

It is possible to overcome mentioned disadvantages by using a continuous concrete paver (Figures 2, 3), which is a sliding formwork moved along the concreted part of the overpass with the help of hydraulic drives.

In order to implement the proposed technological process, the design of the GPV overpass supports should contain heads for anchoring prestressed ropes reinforcing the span structure. The outline of the inner surface of the span structure is provided by an internal fixed formwork (shell), which is strengthened with spacers that are dismantled after the concrete has gained strength. Next, the interconnected upper and lower parts of the concrete paver are assembled, which performs continuous concreting while moving from one support to another. At the same time, another similar concrete paver can move towards it from the opposite support, and symmetrically relative to the first support in the other direction, two concrete pavers moving towards each other can also be concreted. Thus, the technology of balanced or semi-balanced concreting is implemented [7].

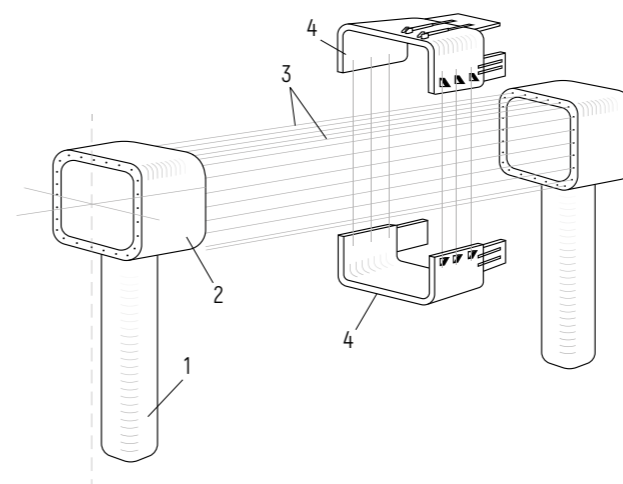

Figure 2 – Installation of a concrete paver to perform the technological process of concreting the span of the GPV overpass:
1 – support; 2 – support head;
3 – prestressing reinforcement (reinforcing ropes);
4 – upper and lower components of the concrete paver

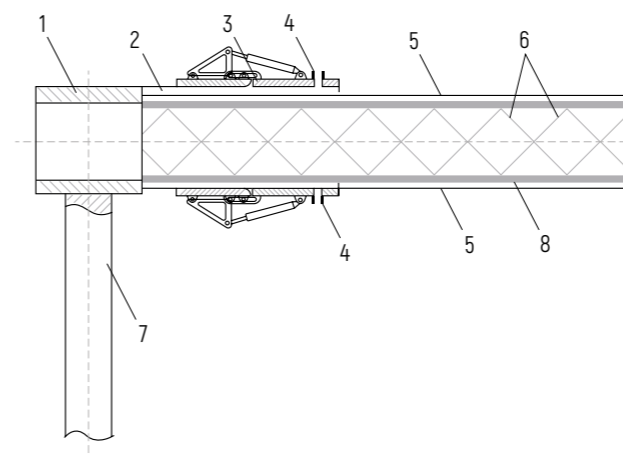

Figure 3 – Technological process of concreting the span of the GPV overpass with the help of a concrete paver:
1 – support head; 2 – span structure; 3 – concrete paver body;
4 – concrete pipe; 5 – prestressed ropes;
6 – spacers of the internal formwork; 7 – support;
8 – internal fixed formwork (shell)

Once the concreting of the span is completed, the concrete pavers are dismantled by means of lifting equipment and moved to the next span. The division of the GPV overpass into sections to be constructed simultaneously by this method optimizes the number of machines and equipment being used and also, thanks to network planning, ensures the required productivity, high quality and acceptable cost of work.

The concrete paver contains hinged sliding formwork and thrust plates, which are used by hydraulic cylinders to push against the hardened concrete (Figure 4). This allows to shift the movable part of the concrete paver, which is a sliding formwork, pushing it away from the thrust plates held by friction forces by an amount equal to the stroke of the hydraulic cylinder rod.

The movement stroke is 0.3–0.5 m. Taking into account the time required for concrete hardening, the daily movement of the concrete paver can be 3–5 m. Thus, the concreting of one span of 300 m long and two half-spans of 150 m will be completed in 30–50 days with counter movement of two concrete pavers (at the same time, two more concrete pavers move in directions opposite from the supports of the considered span).

The division of the land part of the GPV overpass with a length of 8,905 km into sections with the length of 3 km, containing nine spans and two half-spans, allows using four concrete pavers to carry out concreting in 160–260 days (including the time spent on installation and dismantling of concrete pavers – one day per installation, one day for dismantling).

The proposed technological scheme for the use of concrete pavers with the division of the land part of the GPV overpass into 2,969 three-kilometer sections shows that the construction of the entire structure will require 1,187 concrete pavers, the design life of which is 7.5 km.

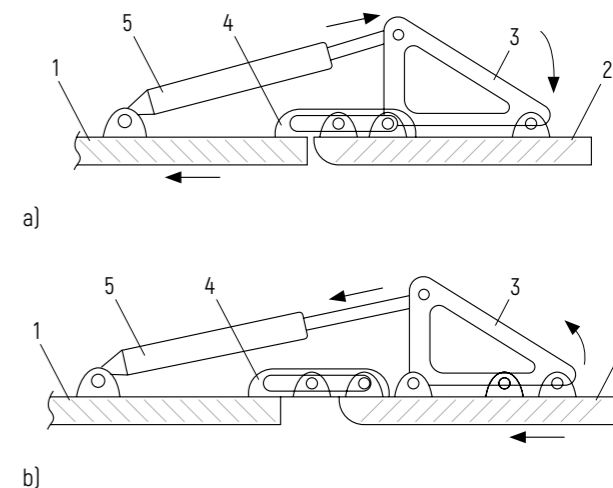

Figure 4 – Design diagram of the mechanism for moving the upper and lower parts of the concrete paver:
a – concreting position; b – position of movement of the sliding formwork (moving part); 1 – sliding formwork (moving part); 2 – thrust plate; 3 – lever mechanism; 4 – guide; 5 – hydraulic cylinder

This means that concreting the spans is possible in 1,600–2,600 days (4.5–7.5 years). If 29,684 supports with the average height of 300 m and the diameter of 3 m are erected, which will take about 1,000 days (2.7 years) and 2,968 sets of sliding formwork with a design life of 3 km, the total construction time of the land overpass will be 2,600–3,600 days (7.2–10.2 years).

The span length of the overpass, equal to 300 m, is taken in this study conditionally. Since the material consumption and, accordingly, the cost of a reinforced concrete span structure is a quadratically dependent on the span length, while the supports are linearly dependent, it is necessary to optimize this value with respect to the height of the supports: the lower the supports are, the shorter the optimal span will be [at zero supports height, the overpass degenerates into a reinforced concrete roadbed lying on an elastic base – into a traditional road with reinforced concrete pavement]. Such optimization in the process of designing the GPV takeoff and landing overpass, taking into account the actual terrain, will reduce the material consumption and cost of the facility by at least two times.

Conclusion

At the current stage of civilization development, humankind possesses the necessary competencies, technologies, materials and technical means to build a complex, extended facility that can withstand high loads and pass through various hydrogeological zones, which is the GPV equatorial overpass. At the same time, the use of modern digital calculation methods, geological and geodetic surveys as well as BIM technologies of design, organization and planning of construction provides an opportunity to manage material, time and human resources in order to optimize and maximize construction efficiency according to the criteria of ensuring high operational reliability and minimizing the construction time and the cost of work.

References

1. *Unitsky, A. String Transport Systems: On Earth and in Space / A. Unitsky. – Silakrags: PNB Print, 2019. – 560 p.*
2. *Unitsky, A.E. Razrabotka konstruksii, izskaniya i proyektirovaniye ekvatoria'Inoy estakady obshcheplanetarnogo transportnogo sredstva [Development of the Structure, Survey and Design of the Equatorial Overpass of the General Planetary Vehicle] / A.E. Unitsky, D.I. Bochkaryov, S.V. Artyushevsky // Vestnik RUDN. Seriya: Inzhenernyye issledovaniya. – 2021. – Vol. 22, No. 2. – P. 205–216.*

3. *Predvaritel'no-napryazhonnyye konstruksii zdaniy i inzhenernykh sooruzheniy [Prestressed Structures of Buildings and Engineering Constructions] / G.I. Berdichevskiy [et al.]. – Moscow: Stroyizdat, 1977. – 207 p.*
4. *Zalesov, A.S. Raschot prochnosti zhelezobetonnykh elementov pri deystvii poperechnykh sil i kruchenii [Calculation of the Strength of Reinforced Concrete Elements Under the Action of Transverse Forces and Torsion] / A.S. Zalesov // Beton i zhelezobeton. – 1976. – No. 6. – P. 22–24.*
5. *Bondarenko, V.M. Raschotnyye modeli silovogo soprotivleniya zhelezobetona [Calculation Models of Force Resistance of Reinforced Concrete] / V.M. Bondarenko, V.I. Kolchunov. – Moscow: Izdatel'stvo ASV, 2004. – 472 p.*
6. *Rayli, I. Mirovaya tsementnaya promyshlennost' i tekhnologiya: proshloye, nastoyashcheye i budushcheye [Global Cement Industry and Technology: Past, Present and Future] [Electronic resource] / I. Rayli, M. Berbidzh, R. Vang. – Mode of access: <https://jcement.ru/reading/cemchem/mirovaya-tsementnaya-promyshlennost-i-tekhnologiya-proshloe-nastoyashchee-i-budushchee/>. – Date of access: 31.08.2023.*
7. *Kurlyand, V.G. Stroitel'stvo mostov [Construction of Bridges]: Study Guide / V.G. Kurlyand, V.V. Kurlyand. – Moscow: MADI, 2012. – 176 p.*
8. *Kiyanets, A.V. Sovremennyye opalubochnyye sistemy [Modern Formwork Systems]: Study guide / A.V. Kiyanets. – Chelyabinsk: Izdatel'skiy tsentr YuUrGU, 2015. – 52 p.*
9. *Komarinskiy, M.V. Betonirovaniye gustoarmirovannykh konstruksiy litymi smesyami [Strongly Reinforced Concrete Design of Cast Concrete Allow Mixtures] / M.V. Komarinskiy, R.V. Oniskovets, O.A. Ostarkova // Stroitel'stvo unikal'nykh zdaniy i sooruzheniy. – 2017. – No. 2 (53). – P. 29–41.*
10. *Khafizov, T.M. Sravnitel'nyy analiz sposoba opuskayushchegosya betona i metoda skol'zyashchey opalubki [The Method of Forming Reinforced Concrete Structures by Means of Descending Concrete] / T.M. Khafizov, A.Kh. Bayburin // Bezopasnost' kritichnykh infrastruktur i territoriy. Problemy bezopasnosti stroitel'nykh kritichnykh infrastruktur: Collection of Articles of the VIII All-Russian Scientific and Technical Conference with International Participation and XVIII School of Young Scientists, IV International Conference, Ekaterinburg, Oct. 4–5, 2018 / UrFU, Scientific and Engineering Center "Reliability and Service Life of Large Systems and Machines" of the Ural Branch of the Russian Academy of Sciences. – Ekaterinburg: NITS "NiR BSM" UrO RAN: UrFU, 2018. – P. 222–228.*



Application of Classical Machine Learning and Neural Networks Training in the Diagnostics and Operation of the General Planetary Vehicle Equatorial Overpass



There is a technology proposed for diagnostics of the General Planetary Vehicle (GPV) equatorial overpass which allows to perform research in the space and transport spheres on the basis of classical machine learning and neural networks training using IMU unit and camera. This set of sensors is the cheapest, most affordable and most reliable in operation variant. The author analyzes the efficiency of different algorithms, such as the support vector machine (SVM) and logistic regression (LR), which show that classical machine learning is optimal for processing large data volumes. The article offers application of neural networks training and transfer learning. The opportunities and limitations of classical machine learning and neural networks training in the context of space and transport research are highlighted. The author's work may be useful for the specialists who maintain the GPV equatorial takeoff and landing overpass.

Keywords:

convolutional neural network, General Planetary Vehicle (GPV), GPV overpass, GTSRB dataset, machine learning, transfer learning, VGG16.

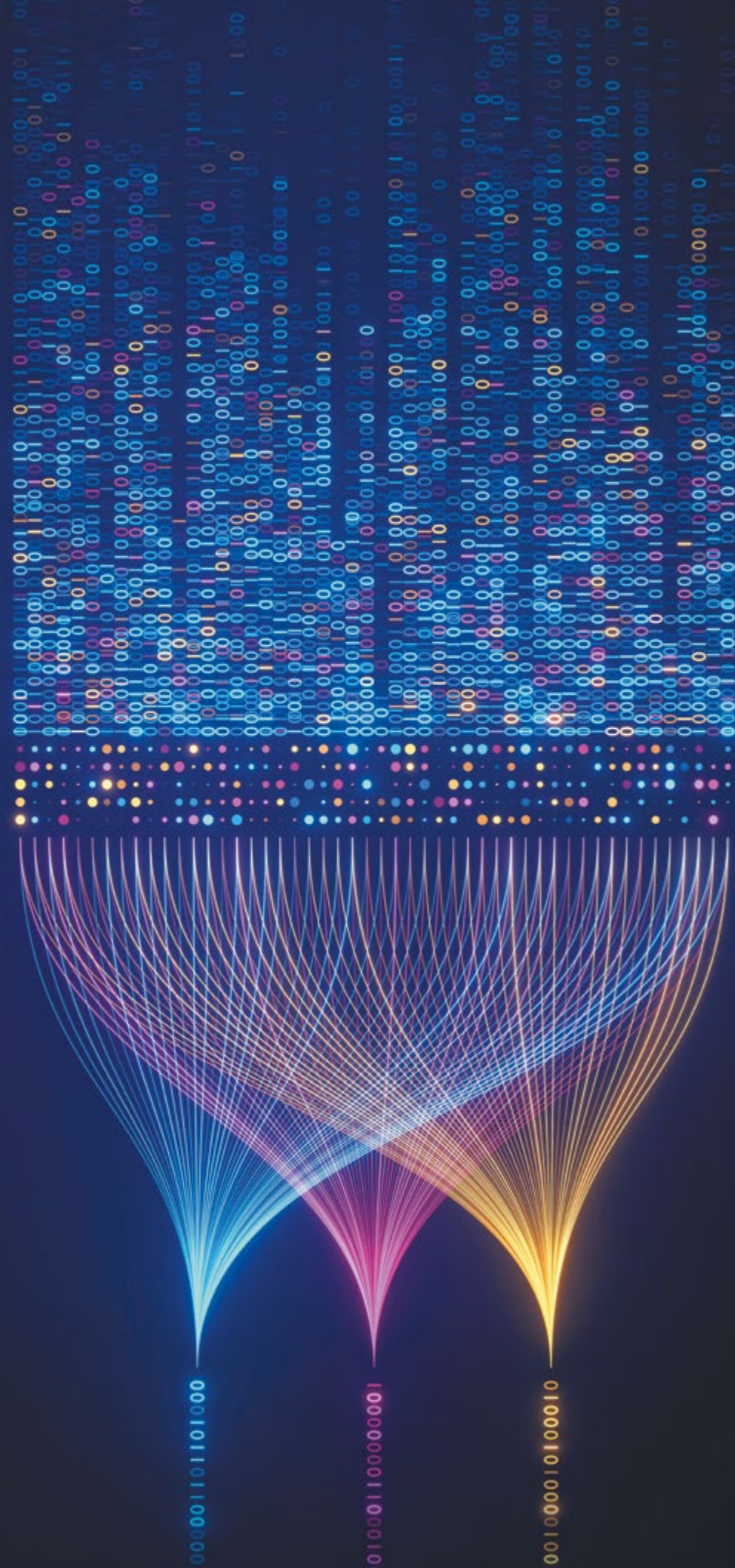

Introduction

The uSpace geocosmic program has the right to be called the most ambitious project of the 21st century. The equatorial takeoff and landing overpass of the General Planetary Vehicle (GPV) has a length of 40,076 km [1-3]. It includes the GPV takeoff and landing runway as well as a rapid (up to 200 km/h), high-speed (up to 600 km/h) and hypervelocity (up to 1,500 km/h) transport and infrastructure complexes of the Unitsky String Transport (uST), providing the terrestrial logistics of geocosmic cargo and passenger transportation. The maintenance and analysis of such a large-scale infrastructure can be very costly.

Let us consider possible methods for analyzing long structures. For example, as of 2018, there were 43,670 km of public roads in Slovenia, which is only 8.9 % more than the GPV land infrastructure. However, even in such a traditional sector, there are challenges with timely maintenance and, most importantly, real-time monitoring of road conditions. The simplest solution is to use classic tools in the field of machine learning such as the support vector machine (SVM) and logistic regression (LR). The study dataset is taken from open sources [4].

Another potential application of SVM and LR is to assist in vehicle positioning when GPS signal is absent or weak. The existing technical solutions include the installation of signal tags on the overpass support towers in the format of traffic signs containing information on locations.

In order to diagnose the condition of the GPV equatorial overpass, the author proposes the following methods:

- classical machine learning, which uses data from an inertial unit – reading the velocity, acceleration, height and position of the rolling stock and elements of the overpass in space;
- training of a recognition model using neural networks by means of cameras – the location of vehicles is determined through visual tags.

These methods can form the basis of an auxiliary or key function of an automatic control system.

The purpose of this article is to analyze the accuracy of the tools based on the available dataset; compare two types of algorithms and evaluate the feasibility of the tools.

Controlled Machine Learning (SVM and LR)

To ensure the safe movement of hypervelocity transport on the GPV equatorial overpass as well as to diagnose

the condition of the track structure it is proposed to use classical sensors such as a camera and an inertial unit but to do it in a completely new way. As it is known, machine learning requires a lot of data from a really operating system: for sign detection and recognition at least 30,000 images are required. For this reason, data from open sources, which are the closest to the data that can be obtained during the operation of the equatorial overpass, are taken as a basis for the study. Training of the model using information from the inertial unit is presented below.

The open dataset is taken from available foreign sources [5]. The task is to show the controlled analysis of vehicle dataset and compare any two classification algorithms to achieve the best results. The research process studied the dataset, recognized functions, processed and formatted the data to eliminate inconsistency, identified two possible models (logistic regression and machine learning support) selected among several algorithms. The following metrics were compared: accuracy, balanced accuracy and *F1*-score. The results of the metrics were analyzed relatively to the models and the selected functions. The final version of the project is compiled in separate code blocks, which are merged into the GitHub repository [6].

SVM is the algorithm of controlled machine learning, which is required for classification or regression. SVM acts by separating the input data into classes using hyperplanes with maximum margin [4]. Although SVM is designed for binary classifications, it can be applied in polynomial classification by breaking polynomial categories into a set of binary classification problems [7].

LR is another classification method which is an extension of linear regression. It is used to predict the probability that input data belongs to a class. Like SVM, logistic regression is designed as a binary classifier, however, it can be extended for use in polynomial classification. The polynomial logistic regression engages maximum likelihood estimation to predict class membership. The regularization method helps to reduce the generalization error of the learning algorithm but not the training error [8]. Regularization is detrimental to a complex model, hence it can be used to reduce overtraining and improve the model performance [9].

In order to evaluate and compare SVM and LR classification results, probabilistic metrics need to be applied. The metrics studied in this work are accuracy, balanced accuracy and *F1*-score.

Accuracy is the ratio between correct predictions and the total number of predictions. It is a widely used metric

in classification and prediction applications; it is calculated by the following formula:

$$\text{Accuracy} = \frac{\text{Correct classifications}}{\text{General classifications}} = \frac{TP + TN}{TP + FP + TN + FN} \quad (1)$$

where *TP* – true positive predictions;
TN – true negative predictions;
FP – false positive predictions;
FN – false negative predictions.

Accuracy is not a perfect measurement; it produces misleadingly high results when minor classes are misclassified. Using this method is justified when there are an equal number of samples from each class.

Balanced accuracy is a metric that is good at detecting class imbalance in the data. It represents the average value of recall of the model and the correct negative metric; it is calculated by the following formula:

$$\text{Balanced accuracy} = \frac{1}{2} \left[\frac{TP}{TP + FP} + \frac{TN}{TN + FN} \right] \quad (2)$$

The *F1*-score is the average harmonic value of the accuracy and the recall of the model. The maximum value is 1, which is the ideal recall and accuracy, and the minimum value is 0, which represents the worst accuracy and recall. The *F1*-score is an appropriate metric to track when trying to minimize both false positive and false negative values. It is widely used in applications supporting machine learning:

$$F1\text{-score} = \frac{2TP}{2TP + FP + FN} \quad (3)$$

The data obtained from sensors can be vague and unbalanced, which means it needs to be processed before application to ensure the input is valid and meaningful. In study, the unprocessed data was analyzed; numbers with commas were converted to numbers with floating point. Similarly, not-a-number (NaN) values were replaced by the most frequent value in the column using the SimpleImputer module from the scikit-learn package [10]. The unification of columns was achieved by selecting and transforming a standard scalar to scale the variances, which simplifies the data for analysis.

The target features of the open dataset are road surface, traffic and driving style, which are assigned with numerical categories using the standard OrdinalEncoder function from the scikit-learn package [11]. Each of the three features is independent, strongly biased towards one element, as shown in the pie charts (Figure 1). A bias of this nature occurs when one element dominates in the results (e.g., the EvenPaceStyle category accounts for 89 % of all driving style data). This imbalance of attributes will be considered in the final processing.

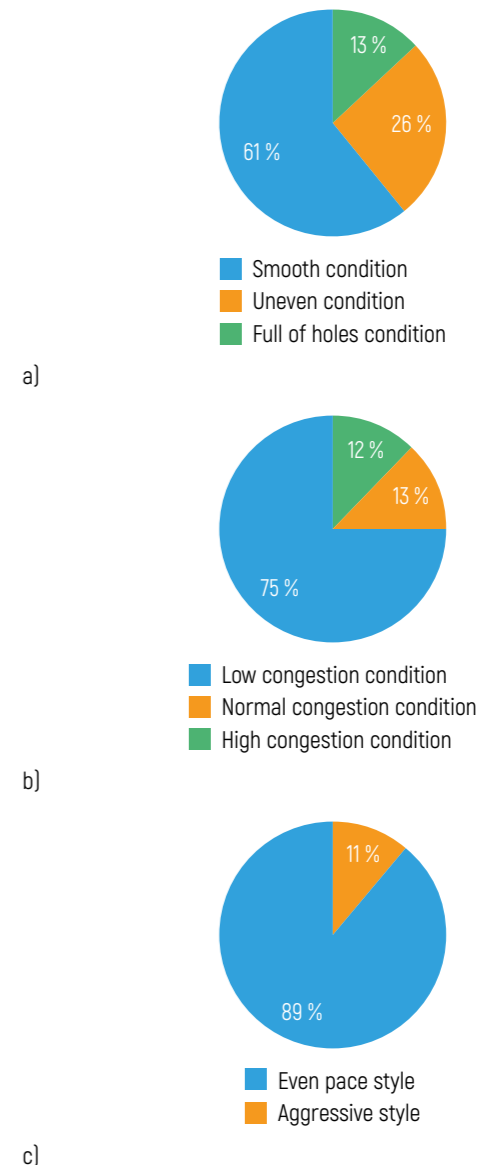

Figure 1 – Analysis of class partitioning of the Kaggle dataset: a – road surface class; b – traffic class; c – driving style class

As it can be seen from the above, the imbalance of different tags in the target variables affected the classifiers' accuracy and balanced accuracy: more unbalanced target variables showed higher accuracy and also lower balanced accuracy. This fact indicates that the classifiers did not perform well enough in classifying less frequent tags. The *F1*-score more clearly reflects the low accuracy when using unbalanced data. The approaches of support vectors and logistic regression are similar; the minimum gap in indexes is considered acceptable. The small gap in the metrics is a consequence of different approaches to the loss function or the fact that SVM considers only points near the local boundary and LR considers global boundaries. In a situation with more balanced data, SVM and LR may show larger gaps in the metrics of the two methods. Model improvement is highly dependent on the quality and size of the data.

Thus, the results of LR and SVM models presented in the Table and Figure 2 show the feasibility of using the functions within the framework of diagnosing the track structure of an equatorial overpass. Further studies of more complex models and optimization of hyperparameters may lead to a model suitable for compensating imbalances in the training data.

Transfer Training (VGG16)

The next stage of the work is to investigate the possibility of recognizing signs as data from a camera. The innovativeness of the approach consists in applying the above method to hypervelocity transport by retraining the model of convolutional neural network VGG16.

The convolutional neural network (CNN, or ConvNet) is a class of neural networks specialized in processing data having a grid topology structure (e.g., photographs, images). A digital image is a binary representation of visual data, i.e., a series of pixels arranged in a grid pattern. Each cell contains visual data (brightness, color). Just as neurons in the brain respond to a stimulus only in a limited area of the visual field, called the receptive field in a biological vision system, each neuron in a CNN also processes data only in its receptive field. The layers are configured to find simpler shapes (lines, curves, etc.) first and then more complex images (faces, objects, etc.).

VGG16 is a model of a convolutional neural network (Figure 3) proposed by the Oxford University [12]; it achieves an accuracy of 92.7% - top-5 when tested on ImageNet in the task of recognizing objects in an image. This dataset consists of more than 14 mln images distributed into 1,000 classes.

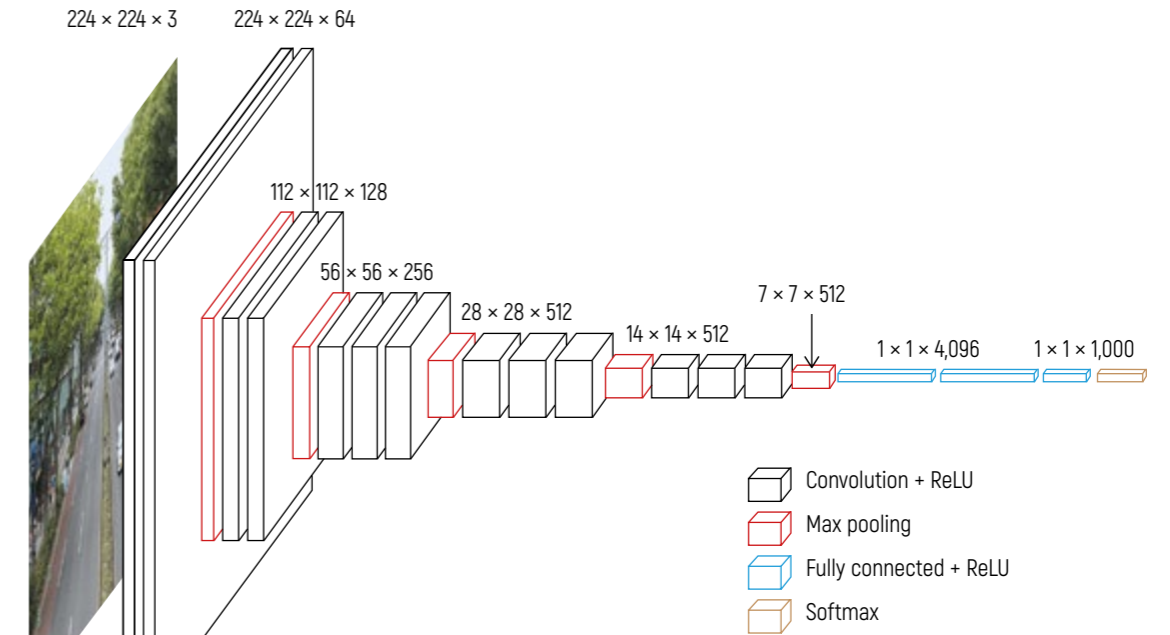

Figure 3 - Architecture of VGG16 convolutional neural network model

Table - Training results

Class \ Index	SVM accuracy	SVM balanced accuracy	SVM <i>F1</i> -score	LR accuracy	LR balanced accuracy	LR <i>F1</i> -score
Road surface	0.782652	0.737606	0.728651	0.778446	0.715456	0.719583
Traffic	0.775441	0.468239	0.45545	0.782051	0.487309	0.499387
Driving style	0.881611	0.5	0.46854	0.880409	0.512502	0.496514

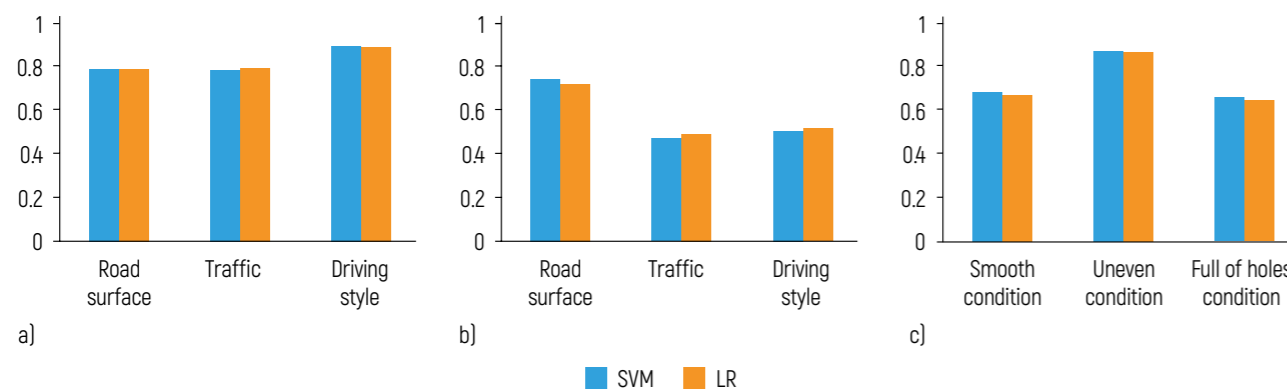

Figure 2 - Training results: a - accuracy; b - balanced accuracy; c - *F1*-score

Transfer learning allows to use the experience accumulated in solving one problem for solving another similar problem. The neural network is first trained on a large amount of data, then on a target set, which requires two components: the availability of a suitable pre-trained model and the reassignment of the model by extracting characteristic features as well as by fine-tuning.

A pre-trained model is a model that has been developed and trained by someone else to solve a problem like ours. In practice, someone with large computational resources creates a large neural network for a specific problem, trains it on big data, such as ImageNet or Wikipedia Corpus, which are opened for use. For example, VGG19 has 143,667,240 parameters and is used for image classification.

In Deep Learning architectures, the initial layers explore general information and the last layer study more specific characteristics. Many models are trained on all sorts of situations. For example, ImageNet contains 1 mln images spread across 1,000 classes, therefore there is no need to change the general picture that the current model sees. Instead, it will be useful to augment it with new specific properties, having only the last layers retrained to reprofile it for your own needs. By affecting more layers of retraining, the risk of overtraining increases.

The selection of characteristic features uses the images obtained from the previous model to add features from new samples, which are then processed by a new classifier. This method requires adding a classifier, which will be trained from scratch, on top of the previously trained model to solve the target function. CNN architectures usually consist of two parts: convolutional and fully connected. While selecting characteristic features, the convolutional part remains unchanged, while fine-tuning captures the last few convolutional layers.

Both methods of reassigning the model can improve its accuracy, but provided there is a sufficient amount of data. Otherwise, the network will not sense changes from the new data set and will not be able to perform profiling.

The extraction of characteristic features is used when the problem solved in the previous network is similar to the target problem. However, if there are significant differences, additional training, which is computationally more expensive, is more appropriate.

The information received from the sensors can be vague and unbalanced. The system will see some road signs at every site and some signs - much less frequently. The GTSRB dataset of the Kaggle system simulated this imbalance.

The total number of all images of the training part of the dataset is 39,209 pieces divided into 43 classes;

the majority belongs to 17 classes and contains 28,710 images, or 73.3 %. This means that the remaining 26 classes contain only 10,499 images, or 26.7 %. A single class can occupy between 5.7 to 0.5 % of the training dataset (Figure 4).

According to the standard VGG16 architecture, the default input data was reduced from 224×224 to 40×40 .

The processing power of the training hardware is limited, therefore rescaling, trimming and centering of all images was performed using the Image Data Generator function. This approach allows to reduce the requirement for computational power of the transport and make the model more affordable.

Thus, feature extraction was chosen instead of fine-tuning because the VGG16 model is trained for solving a similar task and the use of fine-tuning required more time, computational power and preprocessing. The model code can be viewed on GitHub [13].

Figure 5 demonstrates the variability of the dataset used in retraining VGG16 model for sign recognition. The image library was randomly divided into training (90 %) and testing (10 %) data, which served as a control for the accuracy of the solution chosen by the system.

During training, the model showed the following metrics (Figure 6):

- after training for 10 epochs – testing accuracy of 76.6 % and training accuracy of 90.8 %. These results were the starting

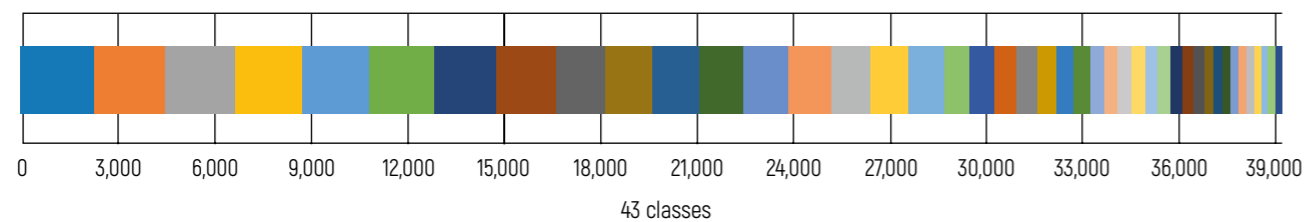

Figure 4 – Analysis of GTSRB dataset

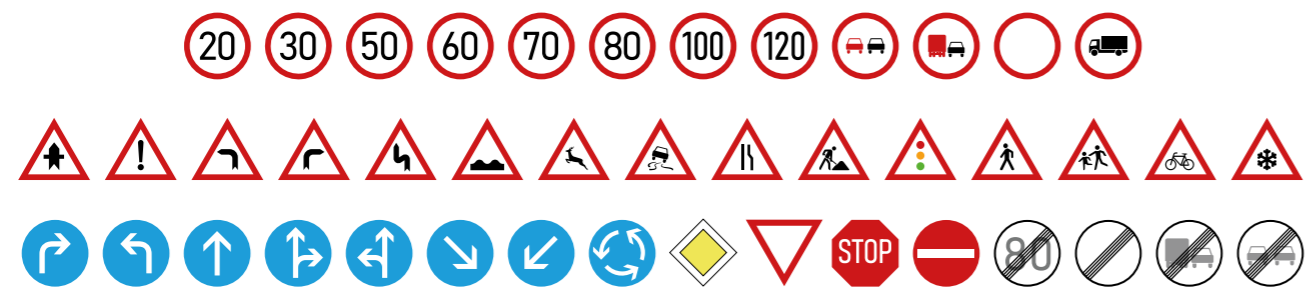

Figure 5 – Signs in GTSRB dataset

point for further analysis. The next steps are to improve accuracy and reduce training losses;

- after training for 30 epochs – testing accuracy of 78.5 % and training accuracy of 94.4 % (i.e., +1.9 % to testing accuracy and +3.6 % to training accuracy);
- after training for 50 epochs – testing accuracy of 78.6 % and training accuracy of 98 % (i.e., only +0.1 % to testing accuracy and +3.6 % to training accuracy).

The obtained results indicate that the most appropriate number of epochs is 30 (matching). A model with 50 epochs increased training accuracy but only by 0.1 % in terms of testing accuracy. These are direct indications of overfitting the model.

In order to improve accuracy, it is necessary to reduce training loss and avoid overtraining – the model needs more training data or a more balanced dataset.

This accuracy of the system does not allow to use the model as a basic security and sign recognition system but it shows a huge potential for its application when a large dataset for training the system becomes available, as the highest training percentage is 98 % (with 39,000 images). If the number of samples is significantly increased, the accuracy can reach 99 % or more. This will make it possible to use the model as part of an automatic control system for the hypervelocity transport of the equatorial overpass.

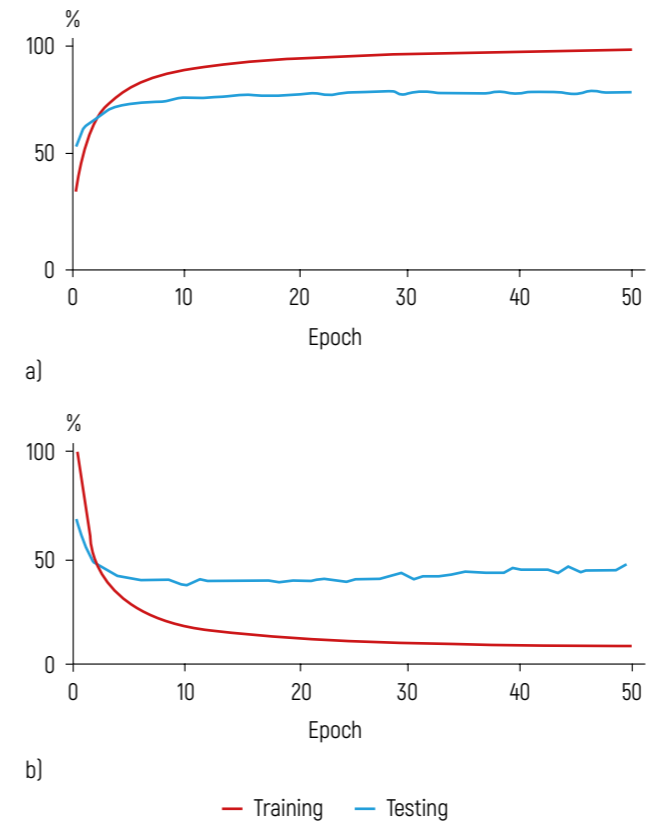

Figure 6 – Graphs of GTSRB accuracy and data loss: a – training accuracy; b – training loss

Conclusion

This article analyzes the capabilities and limitations of two machine learning approaches – classical one and that of neural networks – in the context of transport and future space exploration. The use of classical machine learning methods such as SVM and LR as well as the method of retraining convolutional neural networks based on camera data is proposed. The above approaches have shown sufficient effectiveness for implementation.

The classical machine learning relies on support vector machine and logistic regression and evaluates their effectiveness in dealing with big data.

Training of neural networks is possible through various neural network architectures such as convolutional and recurrent. Their applicability to the GPV was explored and the problems associated with the lack of data in training neural networks for space applications were researched.

In the future, the possibility of combining classical machine learning and neural network training will be considered.

For example, classical algorithms can be used for preliminary data processing and feature extraction, then neural networks can be applied for the final prediction or classification.

It is important to continue to collect and analyze cosmic data or data from the GPV because the more information is available for training, the more accurate and reliable machine learning models can be created.

Such approaches in diagnostics of track structures, construction and operation of the GPV equatorial overpass will contribute to improving the safety of the transport system and at the same time to reducing the cost, as the price of sensors is low and the effect of their use is significant.

This paper makes a considerable contribution to the research on the application of machine learning in the field of autonomous transportation, including the cosmic domain; it is useful for professionals to help them make informed decisions when choosing a data analytics approach for the development of a safe transportation.

References

1. *Non-Rocket Near Space Industrialization: Problems, Ideas, Projects: Collection of Articles of the V International Scientific and Technical Conference, Maryina Gorka, Sep. 23–24, 2022 / Astroengineering Technologies LLC, Unitsky String Technologies Inc.; ed. A. Unitsky. – Minsk: StroyMediaProject, 2023. – 320 p.*
2. *Unitsky, A. The Engineer: Autobiography / Anatoli Unitsky. – Minsk, 2020. – 400 p.: ill.*
3. *Unitsky, A. System Foundations of Non-Rocket Near Space Industrialization: Problems, Ideas, Projects / ed. A. Unitsky. – Minsk: Gradient, 2021. – 568 p.*
4. *Traffic, Driving Style and Road Surface Condition [Electronic resource]. – Mode of access: <https://www.kaggle.com/datasets/gloseto/traffic-driving-style-road-surface-condition>. – Date of access: 08.08.2023.*
5. *Machine Learning in the Internet of Things: A Semantic-Enhanced Approach [Electronic resource] / M. Ruta [et al.] // Semantic Web. – 2018. – No. 10 (1). – Mode of access: https://www.researchgate.net/publication/326965774_Machine_learning_in_the_Internet_of_Things_A_semantic-enhanced_approach. – Date of access: 01.08.2023.*
6. *GusevPortfolio/Comparison-of-SVM-and-LR-in-ML [Electronic resource]. – Mode of access: <https://github.com/GusevPortfolio/Comparison-of-SVM-and-LR-in-ML>. – Date of access: 07.08.2023.*

7. Shmilovici, A. Support Vector Machines [Electronic resource] / A. Shmilovici. – Mode of access: https://link.springer.com/chapter/10.1007/0-387-25465-x_12#citeas. – Date of access: 05.08.2023.
8. Goodfellow, I. Deep Learning [Electronic resource] / I. Goodfellow, Y. Bengio, A. Courville. – Mode of access: <https://www.deeplearningbook.org/>. – Date of access: 08.08.2023.
9. Nagpal, A. L1 and L2 Regularization Methods, Explained [Electronic resource] / A. Nagpal. – Mode of access: <https://builtin.com/data-science/l2-regularization>. – Date of access: 08.08.2023.
10. Sklearn.impute.SimpleImputer [Electronic resource]. – Mode of access: <https://scikitlearn.org/stable/modules/generated/sklearn.impute.SimpleImputer.html>. – Date of access: 09.08.2023.
11. Sklearn.preprocessing.OrdinalEncoder [Electronic resource]. – Mode of access: <https://scikitlearn.org/stable/modules/generated/sklearn.preprocessing.OrdinalEncoder.html>. – Date of access: 06.08.2023.
12. Simonyan, K. Very Deep Convolutional Networks for Large-Scale Image Recognition [Electronic resource] / K. Simonyan, A. Zisserman // International Conference on Learning Representations: Collection of Articles, San Diego, 2015. – Mode of access: <https://www.robots.ox.ac.uk/~vgg/publications/2015/Simonyan15/>. – Date of access: 07.08.2023.
13. GusevPortfolio/Road-Sign-Recognition-model-ML [Electronic resource]. – Mode of access: <https://github.com/GusevPortfolio/Road-Sign-Recognition-model-ML>. – Date of access: 05.08.2023.

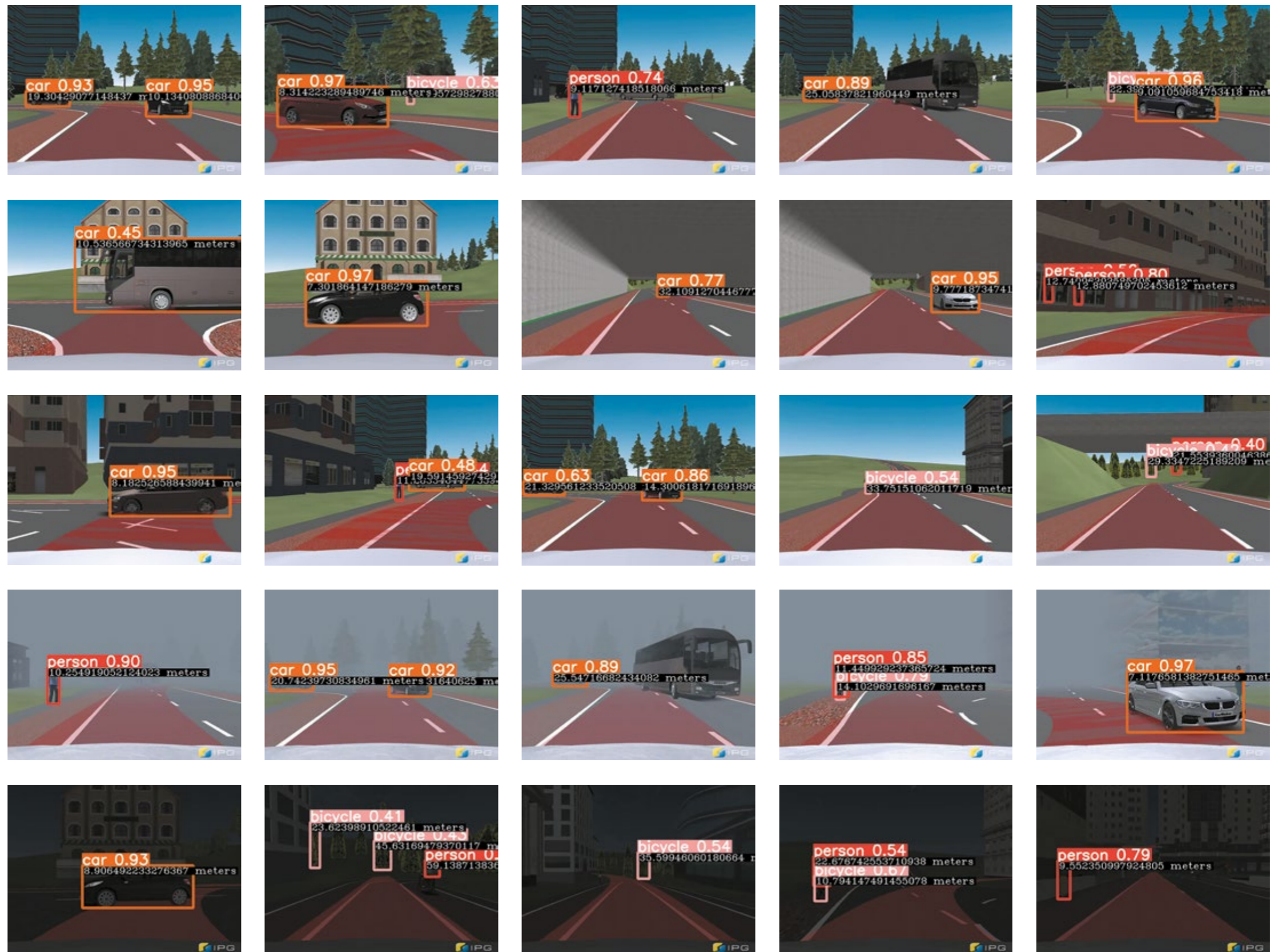



UDC 624.016

High-Rise Inhabited Supports of the General Planetary Vehicle Takeoff and Landing Complex

A. Unitsky^{1,2}
Dr. of Philosophy
in Information Technologies
(Transport)

M. Kubyshkin²

A. Koshelev²

R. Malakhau²

¹ Astroengineering Technologies LLC,
Minsk, Belarus

² Unitsky String Technologies Inc.,
Minsk, Belarus

”

Industrialization of near-Earth space is one of the key tasks of humanity, the engineering solution of which is important to find as soon as possible. The authors of the article made calculations of the potential need for human resources for the space industry functioning in the near future. For the first time, a technical explanation for settlement of service personnel of this industry in the inhabited supports of the General Planetary Vehicle (GPV) takeoff and landing complex (TLC) has been presented. Their functional content was considered, space-planning options were proposed, and an engineering analysis of the possibility to construct the inhabited support with a height of up to 3,000 m was carried out.

Keywords:

General Planetary Vehicle (GPV), inhabited support, skyscraper, space industry, takeoff and landing complex (TLC), Unitsky String Technologies (uST).

Introduction

One of the first human's decisions to demonstrate his rationality was to transfer the hearth outside his home – the cave. At that time, fire was not only a source of heat but also the prototype of a production site. People used fire to realize their first technological solutions: processing animal skins, cooking food, making primitive tools for labor and hunting. Of course, smoke, cinders and soot accumulated inside the dwelling. Sometimes a human died of lung cancer before reaching the age of 20 [1]. From the moment when the fireplace was arranged near the cave – outdoors, people were able to breathe clean air in their homes.

Today, the idea of moving production to near space seems as obvious as our ancestors moved fire outside their homes many thousands of years ago. Now our common home is the Earth's biosphere, inhabited by millions of species of living beings, one of which, and by no means the most important for the biosphere, is human.

According to experts, the following industries are most likely to be transferred to near space: mining, power engineering, metallurgy, chemical production as well as the manufacture of new nonmetallic materials, pharmaceuticals and bioengineering [2].

Despite the continuous progress in automation, industrial production is inconceivable without human. In this article, a study is carried out to determine the number of people needed to set up a space industry, their places of residence and their movements to lead an active lifestyle.

Aggregated Calculation of Potential Requirement in Human Resources for Operation of the Space Industry

According to the World Bank [3], the number of people employed in industry has remained fairly stable over the past 30 years (Figure 1) and is in the range of 204–234 % of the total number of those employed in the world economy. For the purposes of further calculations, we assume the share of the population employed in industry to be 23 %.

The share of those employed in the world economy out of the total working age population has been quite stable for 15 years and amounts to 67 % [4]. In turn, the number of working age people is at the level of 65 % out of the total number of the planet residents; this indicator also does not change for 15 years [5]. Thus, having multiplied the above

values, we obtain the share of those employed in industry out of the entire world population:

$$0.23 \times 0.67 \times 0.65 = 0.1.$$

Based on these aggregated calculations, it can be concluded that the global industry employs about 10 % of the world population. Moreover, this index has remained stable over the past decades, despite the general digitalization and automation of production processes.

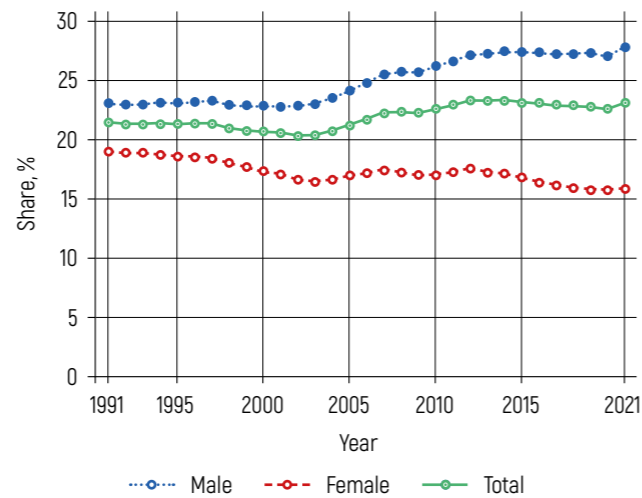

Figure 1 – Share of population employed in industry out of the total number of people employed in the world economy [3]

According to the UN data, the world population in 2050 will amount to 9,687 mln people (Table 1) [6], i.e., about 970 mln people will be employed in the global industry.

Let us imagine that 5 % of the world's industrial production will be located in near-Earth space by 2050. In this case, the potential need in personnel for the full-fledged functioning of the space industry will be about 50 mln people.

Historically, people have settled around large enterprises, creating such communities as single-industry towns (monotowns). Consequently, workers will tend to inhabit an area that is close to the production site – near space (Figure 2). However, there is a serious problem: the human body is adapted to live on Earth only. Over millions of years of evolution, we have suited to the Earth's standard gravitational force, the planet's magnetic and electric fields, the atmosphere enriched with the phytoncides of flowering plants, slightly mineralized spring water and food grown on the Earth's living and fertile soil [1].

Table 1 – Forecast of the world population, mln people

Region	Year		
	2022	2030	2050
Sub-Saharan Africa	1,152	1,401	2,094
Northern Africa and Western Asia	549	617	771
Central and Southern Asia	2,075	2,248	2,575
Eastern and South-Eastern Asia	2,342	2,372	2,317
Latin America and the Caribbean	658	695	749
Australia / New Zealand	31	34	38
Oceania	14	15	20
Europe and Northern America	1,120	1,129	1,125
Least developed countries	1,112	1,328	1,914
Landlocked developing countries	557	664	947
Small island developing states	74	79	87
World	7,942	8,512	9,687

The solution to this problem will be the use of the General Planetary Vehicle (GPV) equatorial overpass supports for living and working, turning them into an analogue of terrestrial single-industry towns which are well known today. Inhabited supports offer prospects for economic growth, technological innovation and the creation of comfortable living spaces. Nevertheless, it is important to examine the challenges that monotowns have faced throughout their history of existence before implementing such an approach.



Figure 2 – GPV and the Industrial Space Necklace "Orbit" – a fundamentally new stage in the development of human civilization

Urban Planning Prerequisites for the Allocation of Inhabited Supports of the GPV Takeoff and Landing Complex

Single-industry towns (Figure 3) are communities whose economic survival depends heavily on a single industry. Although these settlements often thrive in successful times, they face serious problems (Table 2) when their leading industry declines.



Figure 3 – View of a traditional single-industry town

Table 2 – General problems of single-industry towns [7]

Area of the problem	Problem description
Economy	<p>Absence of alternative industries or sources of income, which makes monotowns vulnerable to country-specific and global economic fluctuations and crises.</p> <p>Downturn in the city-forming industry can have serious consequences for the entire city, causing high unemployment and lower incomes</p>
Social and cultural sphere	<p>Decline in the city-forming industry leads to outflow and reduction of population, brain drain.</p> <p>Reduction in population and limited resources cause inefficiencies in local utilities, education and health systems as well as a slowdown in infrastructure development.</p> <p>Decline of primary industry can undermine a community's sense of identity and purpose affecting the well-being of residents</p>

For example, Detroit (Figure 4), one of the symbols of American industrial strength and innovation, has experienced significant regression in recent decades. Many factors have contributed to this:

- loss of the manufacturing industry. The auto industry, which was the backbone of the city's economy, collapsed. The crisis of the major automakers, factory closures and outsourcing led to massive job losses for workers and decreased tax revenues;
- urban decay and abandoned properties. There has been an increase in the number of abandoned buildings and properties throughout the city. This has led to declining property values, limited investment and a reduction in population;
- high crime rate. The city has long been characterized by a troubled crime environment, which has had far-reaching consequences. The perception of a dangerous environment deters businesses from investing and residents from staying. As a consequence, the city's population is declining;
- racial and socio-economic inequalities. Such discrimination has affected education, employment opportunities and the overall quality of life that has hindered the city's ability to recover and attract new investment;
- inefficient financial management. The Detroit's crisis was aggravated for decades of unsustainable management solutions, corruption and political instability. In 2013, the city declared bankruptcy;
- inefficient administration. The absence of a cohesive administrative team and a clear vision for revitalization impeded the recovery of Detroit. The problems of city management prolonged its degradation and made it difficult to implement timely solutions.



Figure 4 – View of Detroit, USA

Economic problems, social and demographic disparities and governmental difficulties have also played a role in Detroit's decline. Although some efforts have been made to revitalize this single-industry town, addressing these challenges is crucial to its long-term recovery. By understanding and overcoming them, dynamic and prosperous cities can be designed [8].

For the full-fledged functioning of the space industry, the settlement of personnel in inhabited supports solves a number of crisis points characteristic of monotowns. Firstly, the transportation and infrastructure efficiency of the GPV, the Equatorial Linear City (ELC) and the Industrial Space Necklace "Orbit" will ensure the rapid distribution of resources (raw materials, energy, food and human resources) between the production facilities located in orbit and on Earth. Secondly, the management of such settlements, based on the principles of autonomous self-governance, will contribute to their sustainable functioning and development, free from the political and economic events on the planet. Thirdly, an equal level of comfort and uniformity of living conditions in the buildings-supports (monotowns) located along the equator will make it possible to exclude mass migration between them.

When implementing the GPV geocosmic complex, the first step is to calculate the required number of such inhabited and/or industrial supports and to determine their locations.

Since the shape of Earth is not exactly spherical but a geoid, the International Astronomical Union (IAU) and the International Union of Geodesy and Geophysics (IUGG) have adopted a conventional definition of the equator as a circle with the radius equal to the standardized radius of Earth (Figure 5). According to the WGS 84 geophysical standard, the radius is 6,378,137 m, while according to the IAU 2009 standard, this radius is 6,378,136.6 m. Both values give an equatorial length of 40,076 km [9].

Based on [10], the length of the distance on land (including islands) is 8,944 km (including 3,596 km of jungle); the length on the oceans is 31,438 km, which in total equals to 40,382 km. It should be noted that the land distance is given taking into account the relief. If counted by the Earth's radius, the length of land in projection on the equatorial circle is equal to 8,637 km.

Thus, sites with a length of only 8,637 km should be considered suitable for the construction of inhabited supports on land. As the GPV overpass supports will be positioned with a spacing of up to 400 m, the number on land will be approximately 21,600. We assume this number of land supports for further calculations.

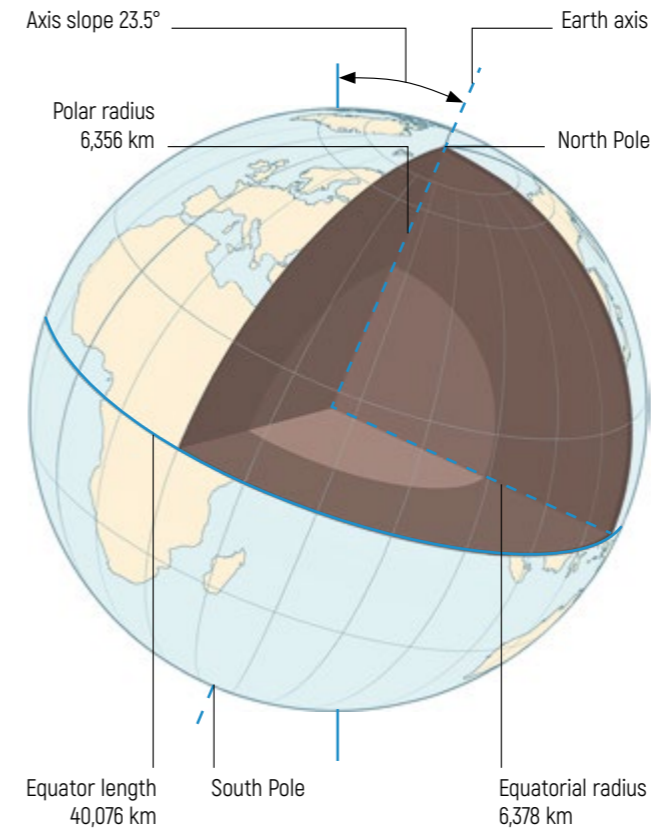

Figure 5 – Diagram of the globe

Let us imagine a support of maximum height in the area where the GPV takeoff and landing complex (TLC) crosses the subequatorial Andes reaching 5,000–6,000 m above sea level. Taking into account the terrain, the height of inhabited supports in this area can reach up to 3,000 m (Figure 6).

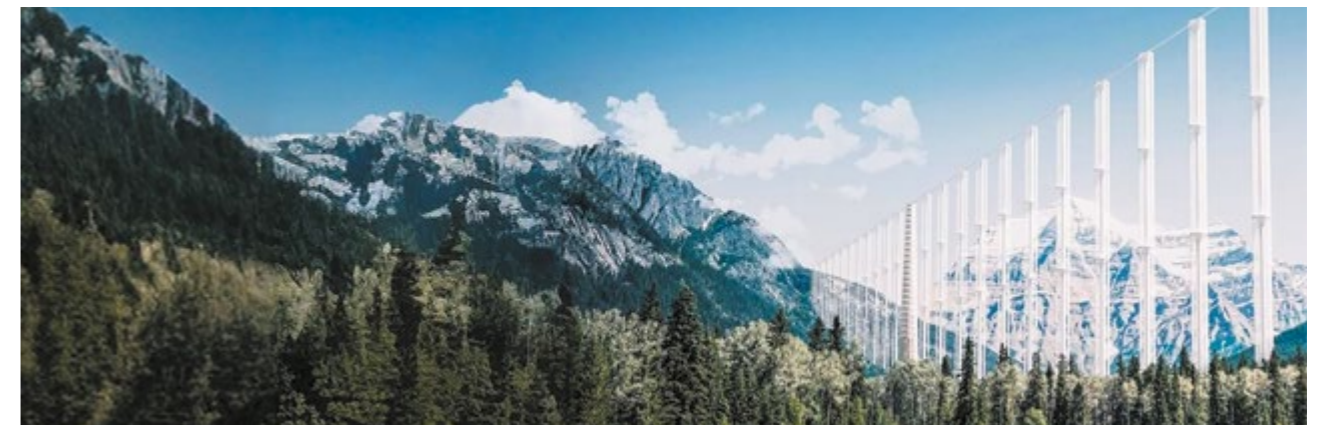

Figure 6 – View of the GPV overpass with inhabited supports of the maximum height in the foothills (option, visualization)

Conquering New Heights – 3,000 m Equatorial Inhabited Support

The world of architecture has always been obsessed with reaching new heights, expanding the boundaries of engineering and design. The structure of a 3,000-meter skyscraper located at the equator and combining innovations and environmental friendliness can be considered. At this height, the inhabited support goes beyond the scope of a simple building; it will become a vertical city (Figure 7).

Its structure assumes residential premises, commercial areas, recreational and entertainment zones, social facilities as well as greenery, which optimizes the use of space and contributes to the creation of a comfortable community atmosphere.

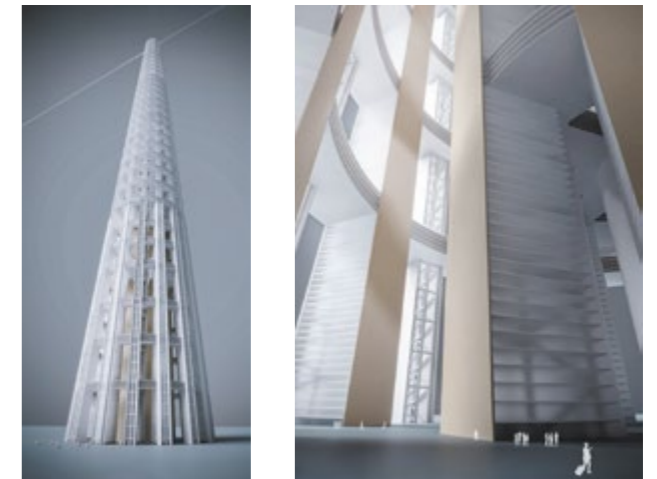

Figure 7 – Inhabited support (option, visualization)

Transportation of people and goods inside the support frame will be carried out by a network of high-speed elevators created by Unitsky String Technology (uST). Priority is given to ease of movement and proximity to attractions.

The main purpose of the GPV TLC inhabited support, like any support of a transport overpass, is to absorb loads from the overlying structures and transmit them to the foundation. However, supports of the GPV overpass have an additional, no less important function – to provide space for human habitation.

The placement of supports along the equator implies the exploration of territories with different natural and climatic conditions and unequal level of socio-economic development. As a result, some supports can be erected in remote and underdeveloped areas, which would require infrastructure development in the conventional view. In our case, all inhabited supports are connected by the GPV TLC belt and uNet string rail transport and infrastructure network, which allows not to carry out special infrastructural preparation on the ground surface. It is possible to consider the concept of operating the inhabited support “top-down”, excluding the need for motor roads, railways, power plants, residential and industrial premises and engineering infrastructure, thus minimizing the environmental impact at the site of construction of the GPV TLC support.

Two levels of transport communication are planned for each support:

- free movement of people and cargo outside the support, using three modes of transport (Figure 8): for long distances – a high-speed one (speed up to 600 km/h); for short distances – an urban one (speed up to 200 km/h); for journeys outside Earth – a planetary one (in 2 h to orbit at a speed of up to 28,000 km/h (7.9 km/s));
- vertical movement within the support by stairs and uST high-speed vertical elevators.

In order to ensure a flat GPV runway surface, there arises a need to erect supports in terrain with a complicated relief. Consequently, they will have different heights and functionality. Despite these variations, the principles for the operation of inhabited supports remain similar, resembling the development of traditional settlements:

- a clear functional division of the support into residential, engineering, social, recreation, industrial and technical zones;
- the shortest possible transport links between functional zones;
- self-organization within each inhabited support as the basis for the control system of the entire GPV complex.

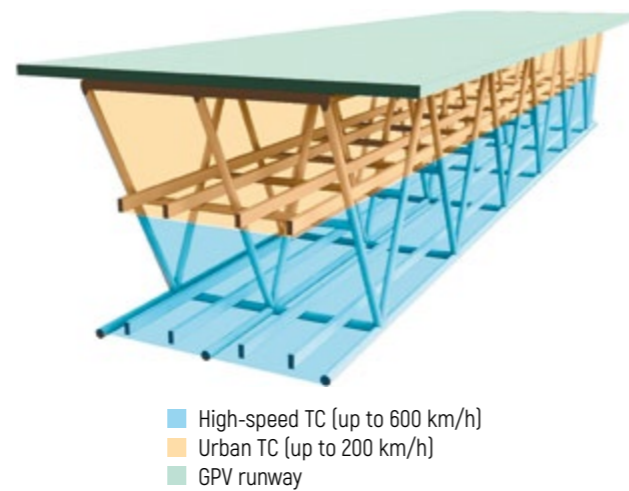

Figure 8 – Distribution of transport complexes (TC) on a truss-type GPV string rail overpass

Dimensional and Planning Solutions of the Inhabited Support

The total volume of the inhabited support with a height of 1–3 km is a truncated cone with a base diameter of 120–360 m and a top diameter of 30–150 m (Figure 9).

The inhabited support includes the GPV station, which also functions as a hub for high-speed and urban transport in the uNet network (Figure 10). The station combines various functions such as passenger boarding and disembarkation, cargo handling, transfer and communication between transport systems. It is located at the top level of the support structure and is designed as an independent unit with vertical and horizontal links. For each direction of transport, safe platforms are provided as well as facilities for loading, unloading, sanitation, waiting and other services.

The middle part of the support consists of alternate blocks of storeys and ventilated spaces (Figure 11). The storeys vary in size depending on their height. The blocks are limited to a maximum of five storeys. The upper level of each block is reserved for landscaping, including lawns, vegetable gardens and fruit trees (Figure 12). The floor areas contain residential, public, social and technical premises. Ventilated spaces are located between the blocks to ensure free aeration and reduce the sailage of the entire support.

The base of the tower (Figure 13) consists of individual high-rise buildings erected next to load-bearing columns and joined together to form a block.

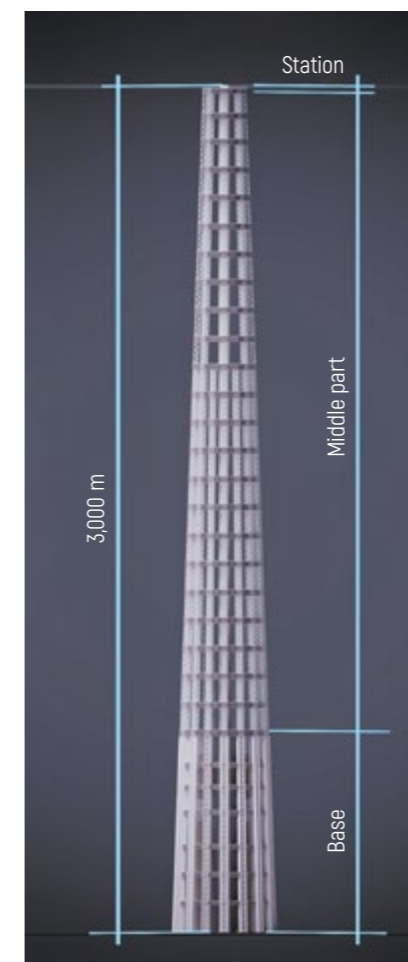

Figure 9 – Vertical zoning of the inhabited support (option)

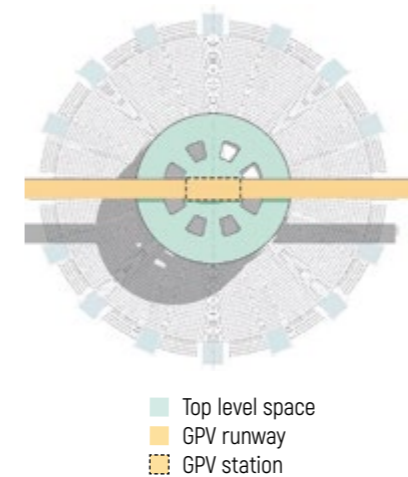

Figure 10 – Diagram of the GPV station at the top of the inhabited support (option)

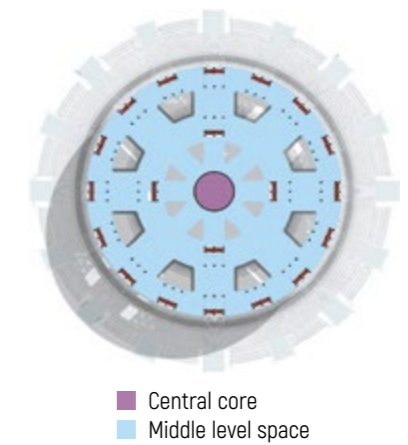

Figure 11 – Diagram of a typical floor in the middle part of the inhabited support (option)

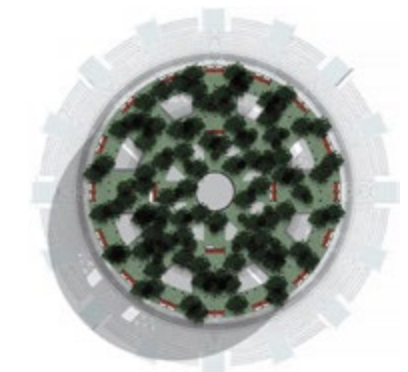

Figure 12 – Diagram of landscaping the roof of tiers in the middle part of the inhabited support (option)

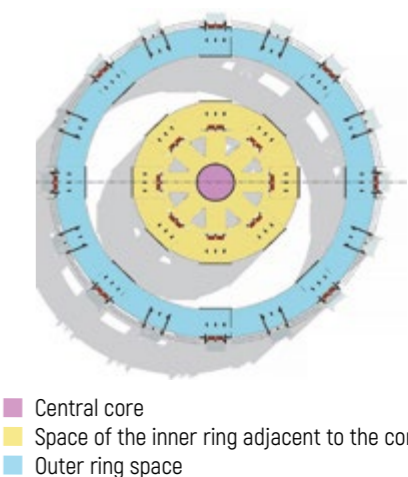

Figure 13 – Diagram of a typical floor in the base of the inhabited support (option)

Technical Parameters of the Inhabited Support

To calculate the technical parameters of the inhabited support, the indicators of the total area and the occupancy capacity of the support are considered.

The total area of the support is calculated as the sum of the areas of all floors and amounts to about 7.3 mln m² for the widest and highest support. For comparison, the data on the housing stock of Minsk in 2017 were used. Thus, according to the information from the Main Statistical Office of Minsk [11], the total area of the housing stock of the Belarusian capital is 44.9 mln m² (population coverage is 22.7 m² per capita).

However, it should be taken into account that the inhabited support will have not only residential zones but also technical, auxiliary, public and production ones. The share of residential premises is supposed to be 3/5 of the total area. So, the housing stock will amount to about 4.4 mln m².

Based on the level of housing provision of 40 m² for each resident, the population of the inhabited support of this size will amount to about 110,000 people. At the same time, it is planned to accommodate not only people involved in the operation of the space industry but also their family members, personnel providing life support services for the support and the GPV TLC. For the purposes of this study, a coefficient of 0.4 is accepted to calculate the number of the support population.

Thus, approximately 40,000 people out of the total number of residents of such a single-industry town will be employed in the space industry. Considering the capacity of each support, it is possible to determine the required quantity of such buildings. According to the calculation made earlier, the space industry will need 50 mln employees. So, the estimated number of inhabited supports is about 1,000 pieces. Since their average height is an order of magnitude lower (about 300 m), approximately 10,000 inhabited supports will be needed. However, the total number of supports required to underpin the GPV equatorial overpass is 21,600 pieces. Thus, almost half of all land supports could be made habitable to provide the space industry with workers.

Taking into account the 8,637 km of length of the GPV equatorial overpass land sections [10], the average distance between the inhabited supports will be about 1 km, which uST urban transport will cover in just a minute. Additional supports for the GPV runway can be designed in a simplified shape – in the form of a main load-bearing core. Subsequently, as the needs grow, it is planned to build floors around it and turn the support into an inhabited one, thus increasing the number of population living in the ELC monotown-supports.

Design Solutions of the Inhabited Support

The implementation of the GPV TLC inhabited support is a complex engineering challenge. Considering the height of the structure (up to 3,000 m), it will be the tallest one in the world. Each such structure is unique, and the labor intensity of its development increases in proportion to its height. For example, more than 400 research teams participated in designing the Commerzbank building (300 m, Germany) [12].

Any high-rise structure is exposed to wind impact, which can easily deflect several meters in different directions, like a swaying tree, without compromising structural integrity (Figure 14). However, such deformations pose a number of problems. One of them is related to the people's comfort in the upper part of the structure. Excessive movements of the GPV TLC support are also dangerous for landing a space vehicle on the platform. Since the GPV has a linear shape (a thin ring about 40,000 km long), a significant shift of the support along with the runway will make the landing difficult.

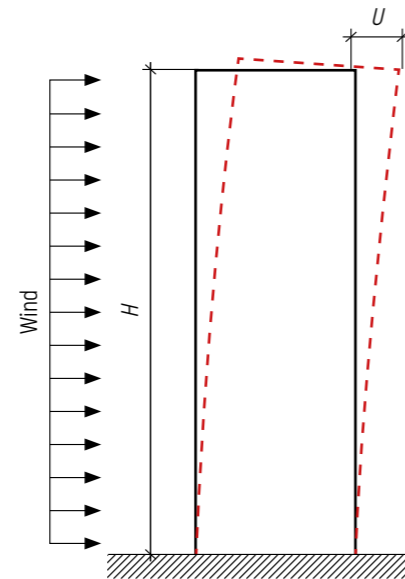

Figure 14 – Diagram of deformation of a high-rise structure due to wind load

Based on physiological requirements and comfort of people staying at height, the horizontal acceleration at the upper floors is limited to 0.08 m/s² [13]. This parameter is achieved by an optimal selection of flexibility and stiffness of the structure. Determination of the balance

between these indicators is another challenge in the design development of ultrahigh structures.

In pursuit of architectural sophistication, many skyscrapers are made in the form of a spiral (Turning Torso, Sweden, Malmö), hyperboloid (Tabung Haji, Malaysia, Kuala Lumpur), arch (Dusit Dubai, UAE, Dubai), square (Taipei 101, Taiwan, Taipei), diagonal (Capital Gate, UAE, Abu Dhabi), strip (Kingdom, China, Shanghai) (Figure 15).

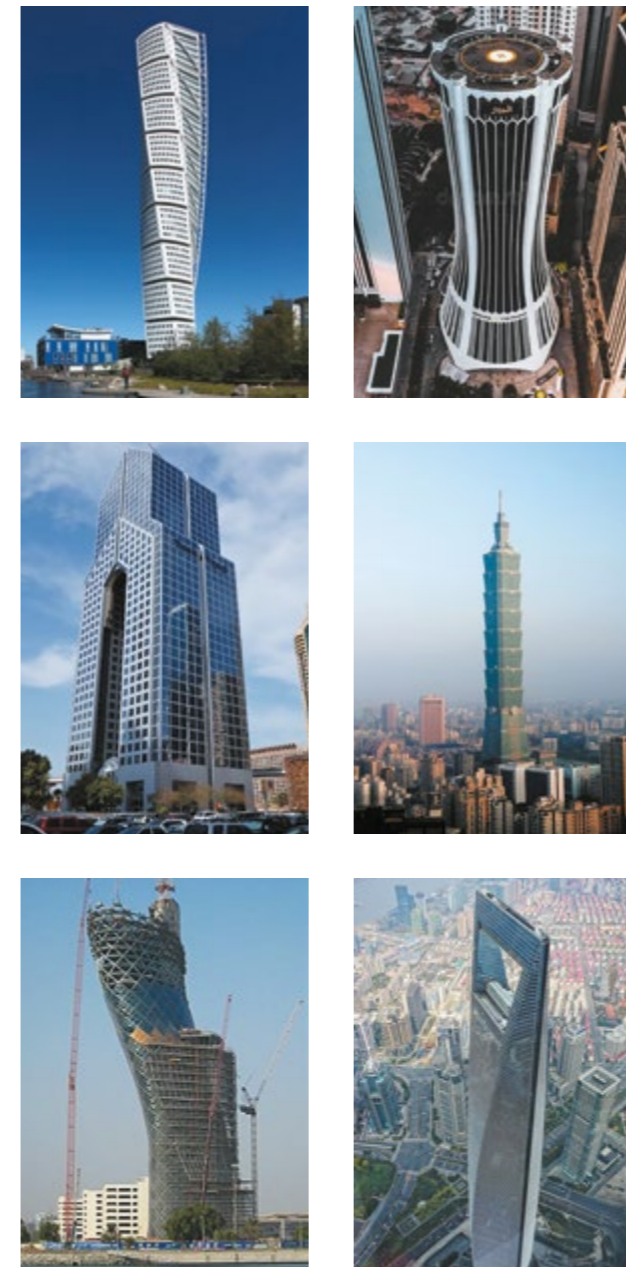

Figure 15 – Architectural diversity of skyscraper shapes

These architectural solutions are not the most acceptable in terms of wind resistance, as these buildings do not have the best aerodynamic qualities, due to which it is necessary to develop cross sections of load-bearing structures. Skyscrapers of the linear city with a height of 300 m are designed in the form of cylinders – a more optimal shape from the point of view of aerodynamics (Figure 16).

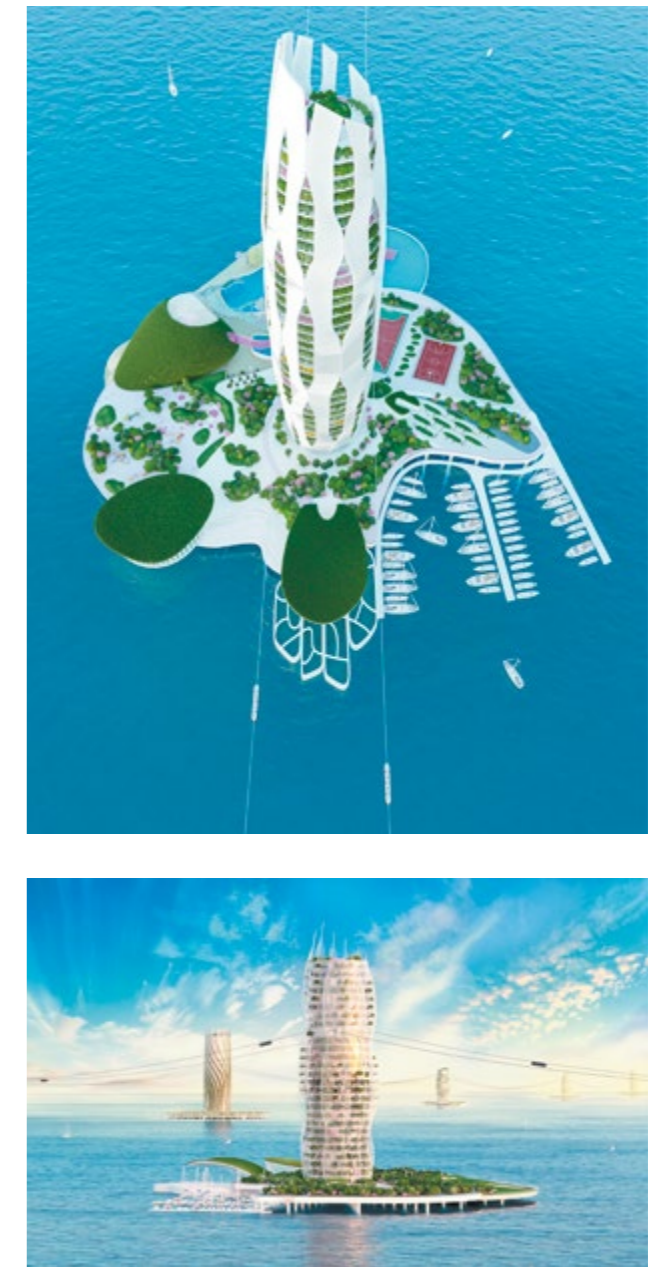

Figure 16 – Skyscrapers of the linear city (visualization) [14]

The inhabited support of the GPV equatorial overpass is planned to be made in the form of a truncated cone. The aerodynamic loads and vertical weight distribution of the building structures require that this configuration is maintained over the entire height. With such a shape of the structure, the wind impact is reduced to the lowest possible values (Figure 17). Thus, from the aerodynamic point of view, a truncated cone is the most optimal shape for the GPV TLC support up to a height of 3,000 m. The absence of projections allows the air to flow around the volume without creating the swirls that appear at the corners of rectangular buildings. This support has many through openings along its height, which make it easier for wind streams to flow around the volume of the structure; hence, the pressure area of the wind load is reduced.

In addition, horizontal shifts of buildings are usually limited to the value $h/500-h/600$ (h – height) [13]. For example, for a 500 m high building, the maximum allowable shift would be 1 m (Table 3).

The peculiarity of the highest inhabited support is that, despite its height (3,000 m), the horizontal shifts will not exceed 4.6 m (1/652), which can guarantee the living comfort of people on the upper floors (Figure 18). This is achieved due to the rational shape. A great advantage is also the fact that each high-rise support is reinforced in the upper part with prestressed (stretched) uST string rail track structures, which are part of the equatorial transport and infrastructure network uNet with longitudinal and transverse string communications. As a result, the structure in one of the directions works not as a cantilever bar but as a post stiffened along the GPV runway and rigidly connected to the base.

The higher is the building, the stronger is the impact of the wind load, which in addition to large displacements causes significant forces in the load-bearing structures. The construction of buildings in the form of an undeveloped thin rod (e.g., 432 Park Avenue, USA, New York (Figure 19)) is also not an optimal solution in terms of structure performance.

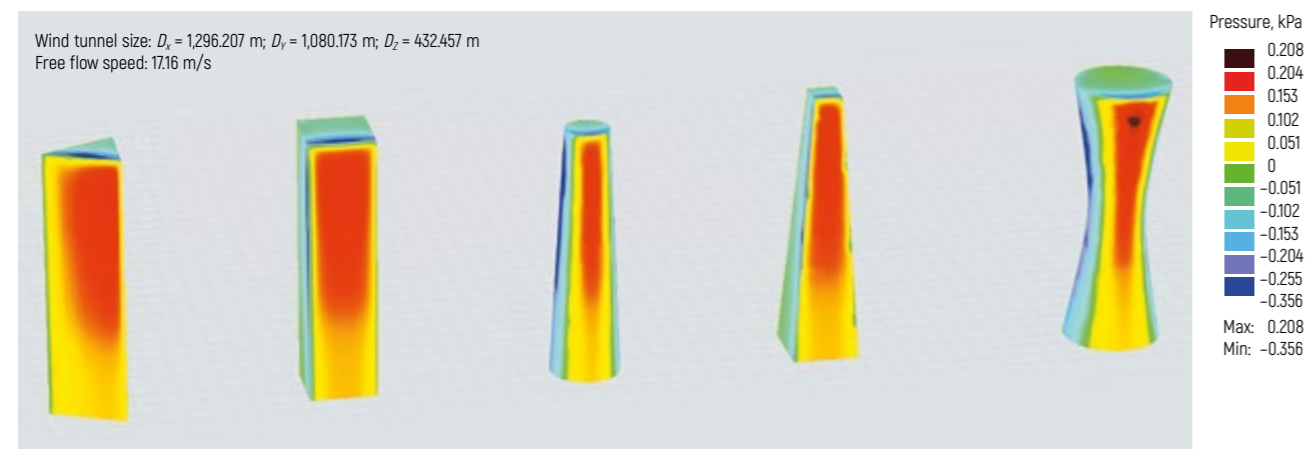

Figure 17 – Modeling results of blow-off of a prism, parallelepiped, cone, pyramid and hyperboloid in a wind tunnel

Table 3 – Maximum horizontal shifts of the upper floors in the world's tallest buildings

Building	Height, m	Horizontal shift, m	Relative shift	Reference
Merdeka 118, Malaysia, Kuala Lumpur	678	1.2	1/456	[15]
Ostankino TV Tower, Russia, Moscow	540	6	1/90	[16]
Burj Khalifa, UAE, Dubai	829	1.5	1/550	[17]
432 Park Avenue, USA, New York	426	1.5	1/284	[17]
Empire State Building, USA, New York	381	0.7	1/540	[17]
GPV TLC support	3,000	4.6	1/652	-

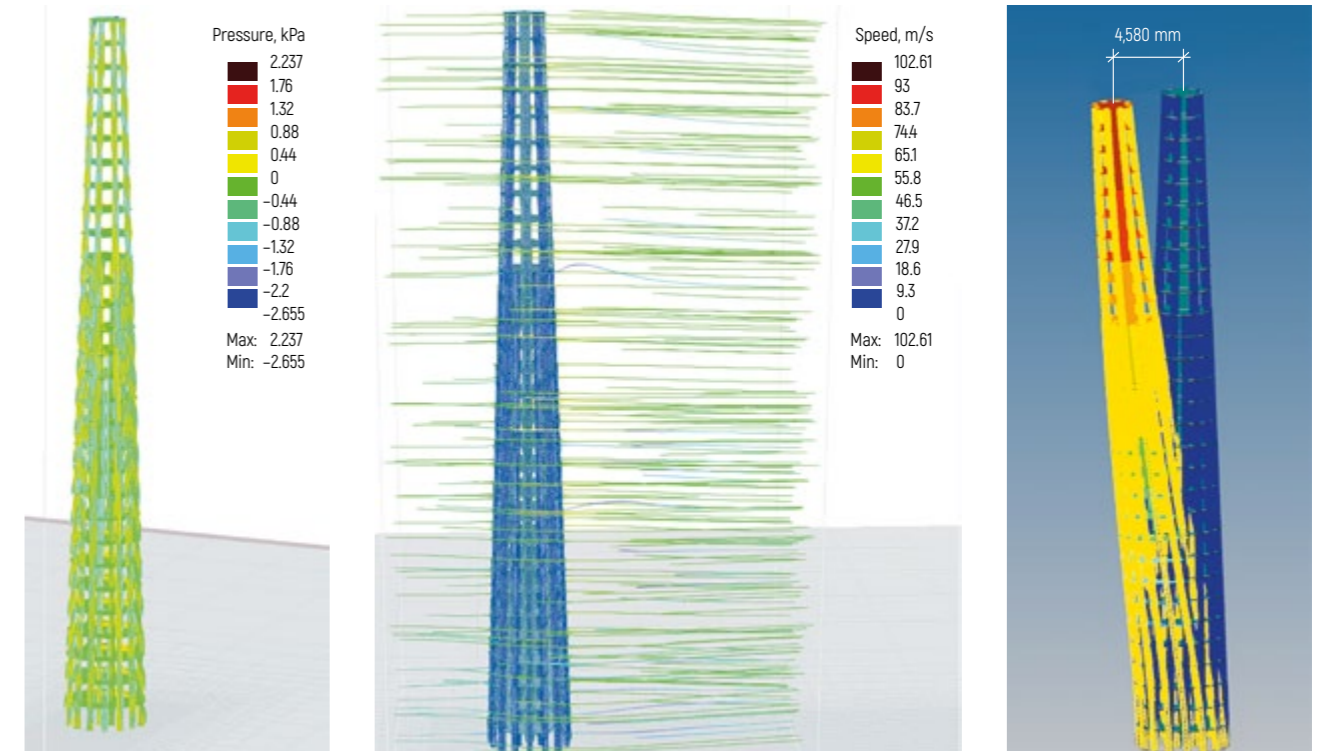

Figure 18 – Modeling of blow-off of the GPV TLC inhabited support in the wind tunnel: horizontal deflections



Figure 19 – Building 432 Park Avenue, USA, New York

The wind causes the building to sway, with the structures experiencing stretching in the wind action plane and compression on the opposite side. It is known that the bending moment at the base of a pinned rod is decomposed into a pair of forces, and the larger the shoulder, the smaller the value of the pair of forces will be, therefore, the smaller the cross sections of the load-bearing structures will be (Figure 20).

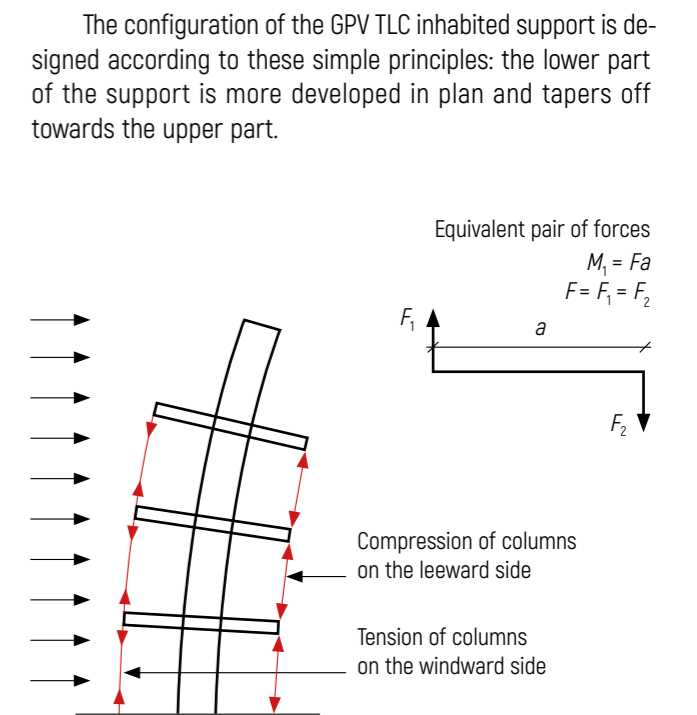

Figure 20 – Diagram for determining the equivalent pair of forces

Table 4 presents the data on bending (overturning) moments at the base of some skyscrapers and the GPV TLC inhabited support. While the need to absorb wind loads requires increased stiffness, seismic effects, on the contrary, dictate an increase in the flexibility of the structure, so that the vibrations are damped by the structure without destroying it. The optimum height to width ratio is between

1 : 8 and 1 : 10. Larger values lead to unacceptable vibrations at the top of the building, and the use of damping elements is mandatory. The width of a 3,000 m high GPV TLC support in one of the versions is 360 m at the bottom and 150 m at the top. The modern design of a reliable ultrahigh GPV TLC support includes: external space trusses (towers), a stiffening core, horizontal rigid disks (outriggers) (Figure 21).

Table 4 - Overturning moment at the foundation base of the GPV TLC support and other skyscrapers [15, 18]

Description	Building	Shanghai World Financial Center	Lotte World Tower	CTF Finance Centre	Merdeka 118	Burj Khalifa	GPV overpass support
Location		China, Shanghai	South Korea, Seoul	China, Guangzhou	Malaysia, Kuala Lumpur	UAE, Dubai	Equator
Height, m		492	55	530	535	828	3,000
Basic wind velocity, m/s		45	43	43	35	45	23
Overturning moment from wind at the foundation base, MN·m		25,000	21,000	37,000	34,000	22,000	54,000

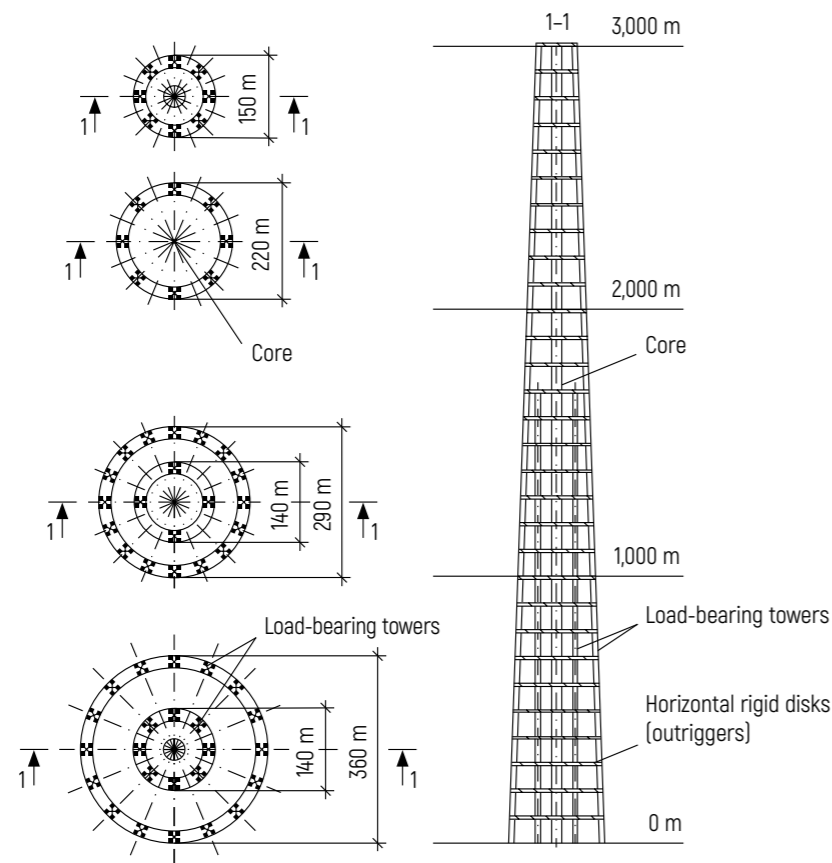

Figure 21 - Load-bearing structures of the GPV TLC ultrahigh inhabited support

The design provides for the pretensioning of high-strength steel ropes from the inside of the reinforced concrete stiffening core, which has significantly increased the stiffness of the support and enhanced the frequency of its own vibrations. In one version, 800 ropes with a diameter of 50 mm are placed inside the core; the total tension is 64,000 tons. This principle was used, in particular, in the construction of the Ostankino Tower in Moscow (Figure 22): due to prestressing of the stem, the horizontal deflection of the building was reduced from 12 m to 6 m.

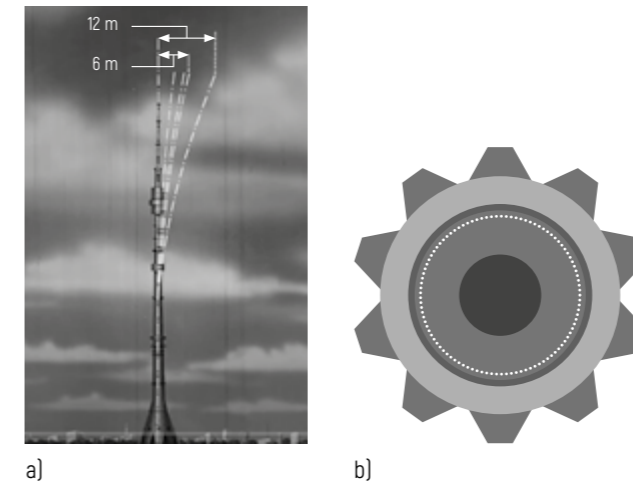

Figure 22 - Ostankino Tower:
a - diagram of movements;
b - prestressing of the stem with ropes [16]

To understand the effect of core prestressing, let us take an example with wooden coils, which are strung like beads on a strong cord (Figure 23). The cord is secured at the top with a knot to prevent it from slipping through the coil. When the cord is stretched, the coils are lined up vertically. The bottom coil can then be tilted any way, but all the coils will keep the tower shape unchanged. The explanation of this effect is as follows: the rotation of one coil relative to its neighbor causes the cord to lengthen. Such deformation requires work to be done. The work increases the potential energy of the cord. However, as it is known, any mechanical system tends to the state that corresponds to the minimum of its potential energy.

The additional stiffness of the ultrahigh support also protects it from earthquakes. Since the building moves in accordance with the horizontal vibrations of the Earth's crust, the frame is neither twisted nor stretched.

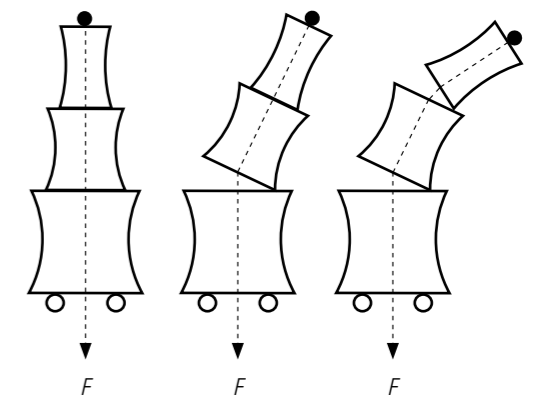

Figure 23 - Operation of cord tensioning on the example of coils [19]

Every 100 m along the height of the support, a 12 m high outrigger floor (for three floors of the building) is constructed. It consists of metal structures acting as a horizontal rigid disk (horizontal trusses). Such elements are a kind of stiffening ring for the skyscraper that keep the shape of the building in the horizontal plane (Figure 24).

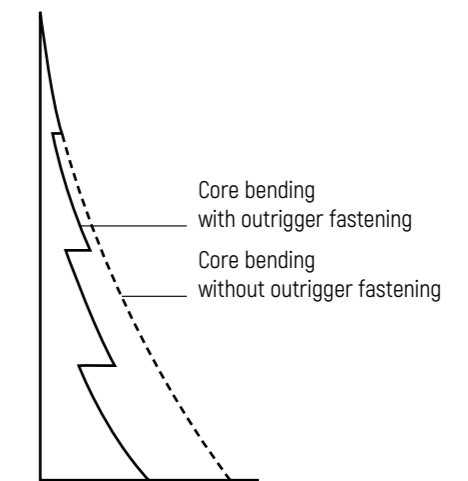

Figure 24 - Epure of moments of the stiffening core with outriggers from the wind impact

O outrigger floors help to distribute the load between the core and columns of the outer spatial truss. In case of an instantaneous destructive effect (e.g., an aircraft impact), the consequences should be minimized. In practice, this means that even if part of the perimeter columns in the GPV overpass supports are destroyed, the outriggers will distribute the load to the remaining stability elements.

Outrigger systems can be horizontal, diagonal, two-storey or without banding trusses or vertical links. The design for each high-rise building is unique and can vary according to its height within the same facility (Figure 25).

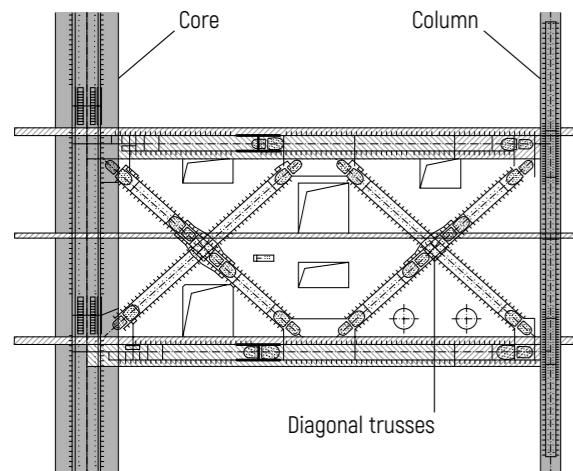

Figure 25 – Internal structure of the horizontal composite outrigger at the public and business complex Lakhta Center, Russia, St. Petersburg. The height of the truss is two storeys (8.4 m) [20]

Structurally, horizontal rigid disks fulfill several functions at once: increase in bending stiffness of the building and resistance to wind loads as well as resistance to progressive collapse.

The use of logical design principles and global experience in construction of high-rise structures allows to create a GPV TLC inhabited support complying with all reliability and serviceability requirements.

Conclusion

The implementation of the global uSpace geocosmic program not only requires the construction of the GPV and its equatorial overpass but also implies the settlement of people in close proximity to the places of labor application, namely the space industry.

The authors have presented an innovative solution – inhabited supports of the GPV overpass. They are made in the form of a truncated cone, which is optimal for structures of such height (up to 3,000 m). The provision of life activity near the workplace will reduce the time spent by employees on “work – home” journeys and will provide an opportunity to work in near space and to live on Earth.

References

1. Unitsky, A. *Historical Background of the SpaceWay Program as the Only Way to Sustainable Development of the Technocratic Civilization* / A. Unitsky // *Non-Rocket Space Industrialization: Problems, Ideas, Projects: Collection of Articles of the II International Scientific and Technical Conference, Maryina Gorka, Jun. 21, 2019* / Astroengineering Technologies LLC; ed. A. Unitsky. – Minsk: Paradox, 2019. – P. 23–29.
2. Babayan, A. *Space Industrialization Is a New Era of Human Development and a Necessary Step to Save the Earth's Biosphere (Economic Justification)* / A. Babayan // *Non-Rocket Space Industrialization: Problems, Ideas, Projects: Collection of Articles of the II International Scientific and Technical Conference, Maryina Gorka, Jun. 21, 2019* / Astroengineering Technologies LLC; ed. A. Unitsky. – Minsk: Paradox, 2019. – P. 103–109.
3. *Employment by Sector* [Electronic resource]. – Mode of access: <https://genderdata.worldbank.org/indicators/sl-empl-zs/?employment=Industry&view=trend/>. – Date of access: 27.07.2023.
4. *Employment Rate* [Electronic resource]. – Mode of access: <https://data.oecd.org/emp/employment-rate.htm>. – Date of access: 27.07.2023.
5. *Working Age Population* [Electronic resource]. – Mode of access: <https://data.oecd.org/pop/working-age-population.htm>. – Date of access: 27.07.2023.
6. *World Population Prospects 2022: Summary of Results* / Department of Economic and Social Affairs, Population Division. – New York: United Nations, 2022. – 48 p.
7. *Monogorod [Monotown]* [Electronic resource]. – Mode of access: <https://www.ru.wikipedia.org/wiki/Монгород>. – Date of access: 30.07.2023.
8. *Что ubilo Detroyt i pochemu vse vdrug zagovorili ob urbanistike? [What Killed Detroit and Why Is Everyone Suddenly Talking About Urbanism?]* [Electronic resource]. – Mode of access: <https://science.theoryandpractice.ru/posts/2593-что-убило-детройт-и-почему-все-вдруг-заговорили-об-urbanistike>. – Date of access: 02.08.2023.
9. *Ekvator [Equator]* [Electronic resource]. – Mode of access: <https://www.ru.wikipedia.org/wiki/Экватор>. – Date of access: 30.07.2023.
10. Unitsky, A. *Equatorial Linear City: Construction Features* / A. Unitsky, M. Davydik // *Non-Rocket Near Space Industrialization: Problems, Ideas, Projects: Collection of Articles*

of the IV International Scientific and Technical Conference, Maryina Gorka, Sep. 18, 2021 / Astroengineering Technologies LLC, Unitsky String Technologies Inc.; ed. A. Unitsky. – Minsk: StroyMediaProject, 2022. – P. 101–115.

11. *Zhilishchnyy fond g. Minska [Housing Stock of the City of Minsk]* [Electronic resource]. – Mode of access: https://www.minsk-city.belstat.gov.by/ofitsialnaya-statistika/sotsialnaya-sfera/zhilischnye-usloviya/godovye-dannye_4/p1/index.php?sphrase_id=1974267. – Date of access: 02.08.2023.
12. Rudenko, A.A. *Innovatsionnyye tekhnologii vozvedeniya vysotnykh zdaniy [Innovative Technologies of Erecting High-Rise Buildings]: Electronic Study and Methodological Guide* / A.A. Rudenko, Ye.A. Ushakova. – Tolyatti: Izdatel'stvo TGU, 2020. – 106 p.
13. *Vysotnyye zdaniya [High-Rise Buildings]: SN 3.02.08-2020*. – Minsk: BelGISS, 2021. – 66 p.
14. Unitsky, A. *The World Engineer: Autobiography* / Anatoli Unitsky. – Minsk: Paradox, 2023. – 496 p.: ill.
15. Ahmad Abdelrazaq – *Constructing Merdeka 118: World's Second-Tallest Building* [Electronic resource]. – Mode of access: https://www.youtube.com/watch?v=a_q-1RUU1rw. – Date of access: 22.06.2023.

16. *Vozvedeniye televizionnoy bashni v Ostankino, 1969 [Erection of a Television Tower in Ostankino, 1969]* [Electronic resource]. – Mode of access: <https://www.youtube.com/watch?v=tQ74kkb7Q4>. – Date of access: 22.06.2023.
17. *Derzhites' krepche: kak shatayutsya bashni i neboskroby [Hold on Tight: How Towers and Skyscrapers Shake]* [Electronic resource]. – Mode of access: <https://www.ria.ru/20170413/408518830.html>. – Date of access: 22.06.2023.
18. Poulos, H.G. *Tall Building Foundations: Design Methods and Applications* [Electronic resource] / H.G. Poulos. – Mode of access: <https://link.springer.com/article/10.1007/s41062-016-0010-2>. – Date of access: 26.06.2023.
19. Dvoryaninov, S.V. *Ostankinskaya telebashnya i... velosipednyy tormoz [Ostankino TV Tower and... a Bicycle Brake]* / S.V. Dvoryaninov // *Potentsial*. – 2017. – No. 11. – P. 37–39.
20. *Mozhet li neboskrob sduť vetrom? [Can a Skyscraper Be Blown Away by the Wind?]* [Electronic resource]. – Mode of access: <https://habr.com/ru/companies/lakhtacenter/articles/399809/>. – Date of access: 30.06.2023.



Hypervelocity Tunnel of the General Planetary Vehicle Equatorial Overpass

A. Unitsky^{1,2}
Dr. of Philosophy
in Information Technologies
(Transport)

A. Shcherbich²

I. Dzyakau²

¹ Astroengineering Technologies LLC,
Minsk, Belarus

² Unitsky String Technologies Inc.,
Minsk, Belarus



The influence of the gas medium on the aerodynamic characteristics of a hypervelocity vehicle moving in a tunnel-type structure is considered. A methodology for aerodynamic calculations has been formed and verified, and a criterion for choosing the ratio of the dimensions of the rolling stock and the inner diameter of the forevacuum tunnel as a component of the equatorial overpass of the General Planetary Vehicle (GPV) has been determined. A method for calculating the maximum possible speed of transport without blocking the flow of the gas medium, depending on the molecular composition of the gas and the ratio of the cross-sectional area (midsection) of the uPod to the passage area of the tunnel internal cross section has been developed. The optimal composition of the gas medium and the preferred cruising speed of the vehicle are proposed. The choice of the fuselage layout diameter value is justified, the values of the forevacuum tunnel inner diameters, which influence the material consumption and overall dimensions of the GPV equatorial overpass, are optimized. A comparative analysis of the energy costs of the hypervelocity uPod and long-haul aviation is carried out, and the economic, social and environmental advantages of tunnel-type transport are presented.

Keywords:

aerodynamics, blocking the flow, equatorial overpass, forevacuum tunnel, gas medium, General Planetary Vehicle (GPV), hypervelocity vehicle.

Introduction

The concept of hypervelocity transport systems is based on criteria that ensure an increase in the speed of transportation and compliance with efficiency and safety indicators. A transport complex with minimal costs for design, construction and operation will be considered efficient. Due to travel at speeds comparable to or higher than air speeds, the working medium of a tunnel can have a major impact on reducing construction and operating costs.

With the development of technologies and the growth of the world economy, there arises the need of humankind to raise the intensity and speed of passenger and cargo transportation. Today, the transport infrastructure is at the limit of its design capabilities [1], and situations that paralyze strategic transport flows are already occurring [2]. Each incident disrupts logistics chains, resulting in passengers being late to connecting flights, and cargo not being delivered on time. Disruption of delivery dates leads to serious financial losses, often significantly exceeding the immediate costs of delivery itself.

According to [3], it is impossible to increase the performance of operating transport systems infinitely. Many of them are already operating at the peak of their capabilities. Mobility in general could be improved by increasing the speed of passengers and cargo movement. This is often not feasible for a whole range of reasons, including safety, design solutions of infrastructure and rolling stock. That is why global business is searching not only for new logistics routes but also for fundamentally new ways of moving to ensure fast, smooth and safe transportation.

One of the most probable solutions to the described problems will be the construction of hypervelocity transport systems [4]. To date, they are a promising method of transportation, guaranteeing high speed and cost-effective traffic [5]. The achievement of financial feasibility of such systems requires the use of a special solutions' set that allows to optimize the parameters and conditions of movement and construction and ensure the uninterrupted operation maintenance. However, there are objects that should necessarily include hypervelocity transport lines in their composition. One of them is the General Planetary Vehicle (GPV) equatorial overpass. Located along the equator, which is 40,076 km long, a hypervelocity route will make it possible to build the Equatorial Linear City, connect countries and continents and establish a reliable and fast cargo and passenger flow necessary for the uninterrupted GPV operation for the purpose of near space industrial exploration.

The movement of rolling stock at transonic velocities involves the consumption of a huge amount of energy. Researchers [6] agree that in order to be economically feasible, transport should move in rarefied air, since the energy required to overcome aerodynamic drag decreases in proportion to the increase in the rarefaction of the medium inside the forevacuum tunnel.

For all the apparent rationality of moving in a tunnel, there is also a significant disadvantage of this technology. As the speed of the rolling stock rises, the velocity of the gas medium increases in the area between the fuselage and the inner wall of the tunnel due to the created narrowing of the tunnel passage cross section. When the speed of the medium flow reaches Mach velocity in this section, there appear forces preventing the further growth of the flow velocity, i.e., the piston effect is observed [7]. This leads to a significant rise in pressure in the forward part of the fuselage and, consequently, to an increase in the energy expenditure required to achieve and maintain the desired high speed.

From the point of view of the financial component of the project designing and transport infrastructure construction, the forevacuum tunnel should be as small in diameter as possible, i.e., the gap between the fuselage and the inner wall of the tunnel should be minimal. However, in this case, the energy consumption to overcome aerodynamic drag even in a rarefied medium will significantly increase and reach the values, at which the feasibility of building a forevacuum infrastructure is canceled out.

To resolve this contradiction, ideas related to the forced removal of the compacted medium, including that with the help of special turbines, are considered [8]. It should be noted that such approach is not optimal, since it implies additional high energy consumption. Besides, the complexity of vehicles increases, their layout volume decreases and the noise level in the passenger compartment rises.

The purpose of this study is to substantiate a fundamentally new approach that solves the existing contradictions of hypervelocity concepts and also makes it possible to reduce energy expenditures and achieve an optimal ratio between the diameters of the hypervelocity uPod and the forevacuum tunnel of the GPV equatorial overpass by replacing air with a more efficient gas medium. For this purpose, it is necessary to identify the main features of alternative gas media in comparison with air, perform aerodynamic calculations and determine the best ratios of diameters (cross-sectional areas) of the hypervelocity uPod fuselage

and the forevacuum tunnel. The obtained data are supposed to be used for a comprehensive comparative analysis of the hypervelocity tunnel advantages as an environmentally friendly alternative to long-haul aviation.

Theoretical Part. Speed of Sound, Flow Blockage Velocity and Drag Force in Gas Media

To optimize the cross-sectional ratio of the forevacuum tunnel and the midsection of the hypervelocity uPod, it is necessary to take into account the impact of the gas medium parameters on the main characteristics of the rolling stock passing through the tunnel.

During acceleration to transonic speeds, the velocity of the air flowing in the cross section between the vehicle and the tunnel can reach the speed of sound long before the vehicle reaches cruising speed. The gas flow passing through the hydraulic or aerodynamic drag associated with a reduced flow cross section into a lower pressure area increases its velocity. If there are subsonic conditions in the forward part of the flow in the direction of travel (before its constriction), the flow velocity increases at the point of constriction (according to the law of conservation of mass). At the same time, the Venturi effect causes the static pressure and hence the density, to drop at the point of constriction. At a certain value of the gas medium velocity, there arise conditions, under which a further decrease in pressure after the constriction does not lead to an increase in the mass flow rate (at constant pressure before the constriction).

For homogeneous gases, the physical point, at which flow blockage under adiabatic conditions is observed, is reached when the linear velocity of the flow reaches the speed of sound or, in other words, when the Mach number value becomes equal to one. The resulting phenomenon, which depends on the speed of sound in a moving medium, is called flow blockage. At its onset, the mass flow rate can increase only if the pressure in the front part of the flow increases. Consequently, for traveling at transonic speeds, it is important to take into account the geometric dimensions of the vehicle and the tunnel.

The aerodynamic characteristics of rolling stock are determined by its speed and can vary significantly depending on the ratio of the vehicle and tunnel dimensions. The indicator of the ratio of the tunnel cross-sectional area to the area of the passage cross section, leading to the phenomenon

of flow blockage for moving at the required speed, was formed by A. Kantrowitz [9].

The critical value of flow blockage at the uPod speed up to 1 Mach is determined by the isentropic limit according to the formula [10]:

$$\frac{A}{A_{pc}} = \frac{1}{M_0} \left(\frac{1 + \frac{\gamma-1}{2} M_0^2}{\frac{\gamma+1}{2}} \right)^{\frac{\gamma+1}{2(\gamma-1)}}, \quad (1)$$

where A – pipeline cross-sectional area, m²;

A_{pc} – passage cross-sectional area, $A_{pc} = A - A_{uPod}$, m²;

M_0 – Mach number;

γ – gas adiabatic index.

Mach number is determined by the formula:

$$M_0 = \frac{v}{v_s}, \quad (2)$$

where v – uPod speed, m/s;

v_s – speed of sound in gas, m/s.

The speed of sound is one of the important parameters of a gas and it depends on its composition, temperature and pressure. It is this speed that determines the rate of pressure transmission in the gas and, therefore, contributes to the diffusion of aerodynamic forces in the tunnel.

The speed of sound is determined by the formula:

$$v_s = \sqrt{\frac{\gamma RT}{M}}, \quad (3)$$

where R – universal gas constant, which is 8.314 J/(mol·K);

T – temperature, K;

M – molar mass, kg/mol.

The Kantrowitz limit is described by the formula (at traveling velocity higher than 1 Mach):

$$\frac{A}{A_{pc}} = \frac{1}{\left(\frac{\gamma-1}{\gamma+1}\right)^{\frac{1}{2}} \left(\frac{2\gamma}{\gamma+1}\right)^{\frac{1}{\gamma-1}}} \times \frac{1}{\left[1 + \frac{2}{\gamma-1} \times \frac{1}{M^2}\right]^{\frac{1}{2}} \left[1 - \frac{\gamma-1}{2\gamma} \times \frac{1}{M^2}\right]^{\frac{1}{\gamma-1}}}. \quad (4)$$

When designing hypervelocity transport systems, it is important to exclude the phenomenon of flow blockage,

because when it occurs, energy consumption to overcome aerodynamic drag increases significantly. The frontal drag force is determined by the formula:

$$F = C_x \frac{\rho v^2}{2} A_v, \quad (5)$$

where C_x – frontal drag coefficient established by full-scale or virtual tests;

ρ – medium density, kg/m³;

v – speed of rolling stock, m/s;

A_v – frontal projection of the cross-sectional area (midsection) of the vehicle, m².

Formula (5) demonstrates that the density of the medium has a great influence on overcoming the frontal drag forces. Due to the design of the forevacuum tunnel, which allows reducing the pressure in it by several orders of magnitude, the frontal drag force can be significantly reduced.

It is important to determine the laws, to which the gas medium obeys, when calculating the transport movement in the medium with reduced pressure. For this purpose, the value of the criterion called Knudsen number [Kn] [11], which characterizes the degree of rarefaction of the gas flow, is estimated.

Depending on this criterion, the method of calculating the motion of the medium at reduced pressure is chosen. If $Kn \ll 1$ (theoretically, $Kn \rightarrow 0$), the basic assumption of hydroaeromechanics about the continuity of the medium is valid, which means that the Euler or Navier-Stokes equations with appropriate boundary conditions can be used in the calculation of the flow [12]. Practically, these methods are valid even at $Kn \leq 10^{-3}$. If $Kn \gg 1$ (theoretically, $Kn \rightarrow \infty$), the aerodynamic characteristics of bodies streamlined by rarefied gas (or flow in vacuum pipelines) should be calculated without considering collisions of molecules among themselves but only their impacts on a solid surface (free molecular flow) [13].

The Kn number is determined by the formula:

$$Kn = \frac{\lambda}{L}, \quad (6)$$

where λ – average free path length of molecules in gas, m;
 L – distinctive flow size (pipeline diameter), m.

The average free path length of molecules in gas is equal to:

$$\lambda = \frac{1}{\sqrt{2} \pi \sigma^2 n}, \quad (7)$$

where σ – molecule diameter, equal for air to 4×10^{-10} m;
 n – concentration of molecules.

The concentration of molecules is determined by the formula:

$$n = \frac{p}{kT}, \quad (8)$$

where p – pressure, Pa;

k – Boltzmann constant, equal to 1.38×10^{-23} J/K;

T – temperature, K.

Substituting formula (8) into (7), the following formula is obtained:

$$\lambda = \frac{kT}{\sqrt{2} \pi \sigma^2 p}. \quad (9)$$

The values of Kn number and mean free path length of air molecules depending on the pressure of the gas medium at the characteristic size of the forevacuum tunnel (diameter 3 m) are presented in Table 1.

Table 1 – Values of Kn number and mean free path length of molecules

Pressure, Pa	Free path length of molecules, m	Kn
101,325	5.6×10^{-8}	1.9×10^{-8}
10,000	5.7×10^{-7}	1.9×10^{-7}
1,000	5.7×10^{-6}	1.9×10^{-6}
100	5.7×10^{-5}	1.9×10^{-5}
10	5.7×10^{-4}	1.9×10^{-4}
1	5.7×10^{-3}	1.9×10^{-3}
0.1	5.7×10^{-2}	1.9×10^{-2}

Table 1 shows that at pressures up to 0.1 Pa, $Kn \ll 1$ ($Kn \rightarrow 0$). Since it is difficult to reach lower pressure in a forevacuum tunnel, it can be concluded that it is fair to use the Euler or Navier-Stokes equations in the flow calculation.

The method described above is applicable for calculations with a reduced pressure in the tunnel – up to 0.1 Pa. The same approach to determination of the calculation methodology is applied for any alternative gas medium.

Research Methods

Analytical Part

To determine the best ratio between the cross section of the forevacuum tunnel and the midsection of the hypervelocity uPod, the following parameters must be calculated based on the characteristics of the gas medium to be used:

- the speed of sound in a gas medium at given values of temperature, pressure and gas composition;
- the rate of flow blockage at given parameters of the gas medium;
- the optimal tunnel diameter considering the obtained calculation results.

The air, oxygen and methane are considered for comparative analysis of flow blockage and relative geometric dimensions of the forevacuum tunnel. Air is chosen as the base gas because it is initially contained in the tunnel.

Alternatives are oxygen and methane; they can be used to run the propulsion system aboard the hypervelocity uPod: oxygen as an oxidizer, methane as a fuel. The advantage of methane is that it is of natural origin, low cost and can be fed into the forevacuum tunnel directly from a gas pipeline. Gases with low molar mass, in particular hydrogen and helium, are also considered. Hydrogen is inapplicable due to its high cost and high explosion hazard grade: even a small amount of air flowing into a tunnel can create an explosive mixture that can completely destroy the transport infrastructure. Helium is an inert gas, but due to its high penetrating capacity, lack of prevalence, difficulty of extraction, and therefore, high price, it is inappropriate as a working medium.

The characteristics of the gases required to perform the comparative calculations are given in Table 2.

Table 2 – Characteristics of the gases under study at atmospheric pressure [14]

Parameter	Air	Methane	Oxygen
Density, kg/m ³	1.27	0.7168	1.429
Adiabatic index γ	1.4	1.32	1.4
Molar mass, kg/mol	0.029	0.016	0.032
Speed of sound in gas, m/s (for $t = 20$ °C)	342.9	448.3	326.5
Mach number for motion at 1,000 km/h	0.81	0.62	0.85

Since the main parameter sought is the inner diameter of the forevacuum tunnel, which ensures the absence of flow blockage, the diameter of the vehicle fuselage with a rounded shape as the initial data has been chosen.

Based on preliminary layouts of the hypervelocity uPod designed by Unitsky String Technologies Inc. (Minsk, Belarus), variants with fuselage diameters of 2 and 2.6 m are identified as promising.

The uPod with a fuselage diameter of 2 m is sufficient for seating two passengers in one row and arranging a central aisle between seats along the entire cabin. In addition, this diameter can also be considered for seating three passengers in one row but without a through center aisle. Certainly, the option with two-seat arrangement is preferable, because in this case the cabin design is considerably simplified and the safety of passengers' access to the vehicle is enhanced, there appears a possibility for quick boarding (disembarkation), movement without discomfort inside the cabin as well as for provision of a restroom. On the other hand, increasing the layout diameter to 2.6 m will allow to accommodate four passengers in one row and provide a through passage in the central part of the cabin.

Both variants have been taken for calculations to obtain the energy efficiency of the hypervelocity transport complex. Undoubtedly, it is necessary to carry out further optimization of layouts, since the midsection area is in direct quadratic dependence on the uPod fuselage diameter.

Having determined the computational fuselage diameters, the formula (1) to calculate the speed value limits of the uPod in the forevacuum tunnel, at which it is possible to move without flow blockage, has been used.

The data for vehicles with diameters of 2 and 2.6 m are displayed in Tables 3 and 4 respectively. The calculations were performed for inner diameters of the forevacuum tunnel from 3 to 12 m with 1 m increment.

The purpose of erecting hypervelocity lines of the GPV equatorial overpass is to provide transportation of cargo and passengers at minimum time and energy expenditures, therefore, the speed range of 900–1,000 km/h (as well as the cruising speed of modern passenger aircraft) is of interest. Using formula (1), let us determine the calculated minimum inner diameters of tunnels, allowing to achieve speeds of 900–1,000 km/h without flow blockage for the uPods with fuselage diameters of 2 m (Table 5) and 2.6 m (Table 6).

In the forevacuum tunnel under project designing at the given gaps between its inner wall and the uPod fuselage, the law of medium continuity preservation will be

observed in the pressure range of 1–101,325 Pa (atmospheric pressure). Consequently, the calculated values of flow blockage speeds from Tables 3–6 are valid practically for the entire assumed range of medium rarefaction inside the tunnel.

As it can be seen from Tables 5 and 6, the smallest tunnel diameter, providing the movement of hypervelocity uPod without flow blockage, is possible when using methane as a filling medium. The most unsuitable of the researched gases is oxygen.

Table 3 – Maximum design speeds of the uPod without flow blockage for a fuselage diameter of 2 m*

Tunnel diameter, m	Tunnel cross-sectional area [A], m ²	Passage cross-sectional area [A _{pc}], m ²	A/A _{pc}	Mach number at flow blockage			Speed at flow blockage, km/h		
				Air	Metnane	Oxygen	Air	Metnane	Oxygen
3	7.07	3.93	1.8	0.35	0.35	0.35	425.9	560	405.4
4	12.57	9.42	1.33	0.5	0.51	0.5	620.9	815	591.1
5	19.63	16.49	1.19	0.6	0.6	0.6	738.2	969.9	702.8
6	28.27	25.13	1.13	0.66	0.67	0.66	817.2	1,073.2	778
7	38.48	35.34	1.09	0.71	0.71	0.71	873.4	1,146.8	831.4
8	50.27	47.12	1.07	0.74	0.74	0.74	913.5	1,202.1	869.6
9	63.62	60.48	1.05	0.77	0.77	0.77	950.6	1,246.7	904.9
10	78.54	75.4	1.04	0.79	0.79	0.79	977.7	1,281.4	930.8
11	95.03	91.89	1.03	0.81	0.81	0.81	999.9	1,310.4	951.9
12	113.1	109.96	1.03	0.83	0.83	0.83	1,018.5	1,334.6	969.5

Table 4 – Maximum design speeds of the uPod without flow blockage for a fuselage diameter of 2.6 m*

Tunnel diameter, m	Tunnel cross-sectional area [A], m ²	Passage cross-sectional area [A _{pc}], m ²	A/A _{pc}	Mach number at flow blockage			Speed at flow blockage, km/h		
				Air	Metnane	Oxygen	Air	Metnane	Oxygen
3	7.07	1.76	4.02	0.15	0.15	0.15	180.1	238.6	171.4
4	12.57	7.26	1.73	0.36	0.36	0.36	445.7	585.8	424.2
5	19.63	14.33	1.37	0.48	0.49	0.48	598.1	786.8	569.4
6	28.27	22.97	1.23	0.57	0.57	0.57	699.3	919	665.7
7	38.48	33.18	1.16	0.63	0.63	0.63	771.9	1,014.1	734.8
8	50.27	44.96	1.12	0.67	0.67	0.67	826.8	1,088.7	787.1
9	63.62	58.31	1.09	0.7	0.71	0.7	869.8	1,141.2	828.1
10	78.54	73.23	1.07	0.73	0.73	0.73	904.6	1,185.7	861.1
11	95.03	89.72	1.06	0.76	0.76	0.76	933.2	1,223.1	888.3
12	113.1	107.79	1.05	0.78	0.78	0.78	957.2	1,254.5	911.2

* The color indicates the options that allow the uPod to reach a speed of 1,000 km/h without flow blockage.

Table 5 – Inner diameters of tunnels providing achievement of travel speeds of hypervelocity uPod with a fuselage diameter of 2 m without flow blockage

uPod speed, km/h	Mach number			Minimum tunnel diameter, m		
	Air	Methane	Oxygen	Air	Methane	Oxygen
900	0.73	0.56	0.77	7.58	4.48	8.84
950	0.77	0.59	0.81	8.99	4.84	10.9
1,000	0.81	0.62	0.85	11	5.25	14.14

Table 6 – Inner diameters of tunnels providing achievement of travel speeds of hypervelocity uPod with a fuselage diameter of 2.6 m without flow blockage

uPod speed, km/h	Mach number			Minimum tunnel diameter, m		
	Air	Methane	Oxygen	Air	Methane	Oxygen
900	0.73	0.56	0.77	9.86	5.83	11.49
950	0.77	0.59	0.81	11.68	6.29	14.16
1,000	0.81	0.62	0.85	14.3	6.83	18.38

Construction of a forevacuum tunnel complex with tunnel diameters in each direction equal to 10 m or more is too costly and economically inexpedient. Guided by the principle of reasonable sufficiency, we will consider a tunnel with an inner diameter of 5 m for a 2 m diameter fuselage and a tunnel with an inner diameter of 6 m for a 2.6 m diameter fuselage as basic and at the same time optimal options for further aerodynamic calculations.

The dynamics of the aerodynamic drag coefficient in the speed range from 0 to 1 Mach should also be taken into account when selecting the gas medium [15]. The calculation of a fuselage model of the hypervelocity uPod, which is promising from the aerodynamic point of view in open airspace, showed a sharp deterioration of the aerodynamic characteristics of the vehicle when it reaches a speed of 0.9 of Mach number (Figure 1).

From the viewpoint of optimizing energy efficiency, the speed of movement in the tunnel should be limited to 0.9 of Mach number. For example, in air medium this limit occurs at a speed of 1,099 km/h, in oxygen – 1,058 km/h, in methane – 1,452 km/h. Even if the phenomenon of gas medium flow blockage is excluded, neither oxygen nor air is able to provide energy efficiency of movement at a speed of 1,100 km/h and more.

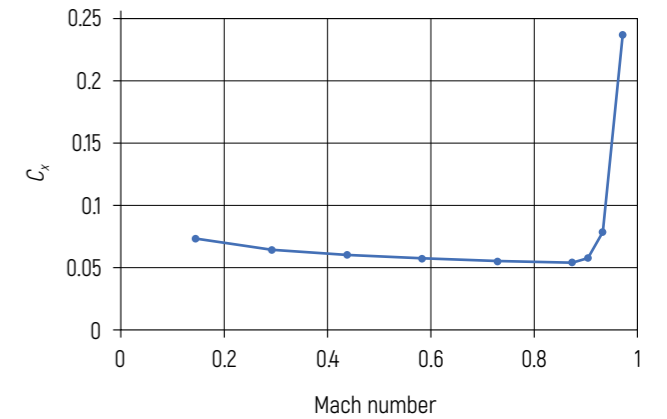

Figure 1 – Diagram of dependence of aerodynamic drag coefficient C_x on Mach number for the hypervelocity uPod when moving in atmospheric air

Verification of Calculated Parameters Using Computer Modeling

In order to verify the calculated parameters of the ratio of cross-sectional areas of the hypervelocity uPod and the forevacuum tunnel, virtual tests were conducted using the ANSYS software package. Initial data: the cruising speed of the uPod is 900 km/h; for a fuselage diameter of 2 m, the inner diameter of the forevacuum tunnel is 5 m; for a fuselage diameter of 2.6 m, the inner diameter of the forevacuum tunnel is 6 m; the length of the uPod is 30 m; the rarefied medium is methane with a pressure of 10,000 Pa (75 mm Hg).

Substantiation of the Choice of Calculation Methodology.

To solve the problem, the *k-ω* SST (Shear-Stress Transport) turbulence model is chosen as a more appropriate one [16].

As a viscous medium, the model of an ideal compressible gas [10] with the dependence of viscosity on temperature according to the Sutherland's formula [11] was considered:

$$P = \rho RT, \quad (10)$$

where *P* – pressure in volume, Pa;
ρ – medium density, kg/m³;
R – gas constant, J/(mol·K);
T – temperature, K.

$$\frac{\mu}{\mu_0} = \left(\frac{T}{T_0} \right)^{\frac{3}{2}} \frac{T_0 + S_{\mu}}{T + S_{\mu}}, \quad (11)$$

where *μ* – medium viscosity, Pa·s;

μ_0 – viscosity reference value, Pa·s;
 T – medium temperature, K;
 T_0 – temperature reference value, K;
 S_μ – Sutherland's constant.

The density-based solver was used as a solver because it is applied to the problem with compressible medium, high flow speeds and low pressure.

Description of the Calculation Model and Boundary Conditions. Based on the initial data, a calculation model was generated (Figure 2).

In modeling the movement processes, a conditionally-reversible calculation method was used, in which the uPod is stationary and the medium is moving.

The following boundary conditions were established:

- the medium inlet is specified by total and static pressure, which in turn determines the inlet flow velocity of 900 km/h;
- the medium outlet with a pressure of 10,000 Pa (75 mm Hg);
- moving wall of the pipe at a speed of 900 km/h.

The initial conditions are 10,000 Pa (75 mm Hg) pressure and 20 °C temperature. To exclude the influence of roughness of internal surfaces of pipe walls on the calculation, frictionless sliding is set.

The finite element model is shown in Figure 3. The number of grid elements is 12,510,335 for a 6 m diameter tunnel and 12,136,532 for a 5 m diameter tunnel.

As it can be seen from Figure 3, the computational grid is formed with a smooth thinning when approaching the fuselage of the uPod as well as at the walls of the forevacuum tunnel. This distribution of computational nodes allows to achieve the value of calculations convergence not less than 10^{-4} for 800–2,000 iterations.



Figure 2 – Calculation model

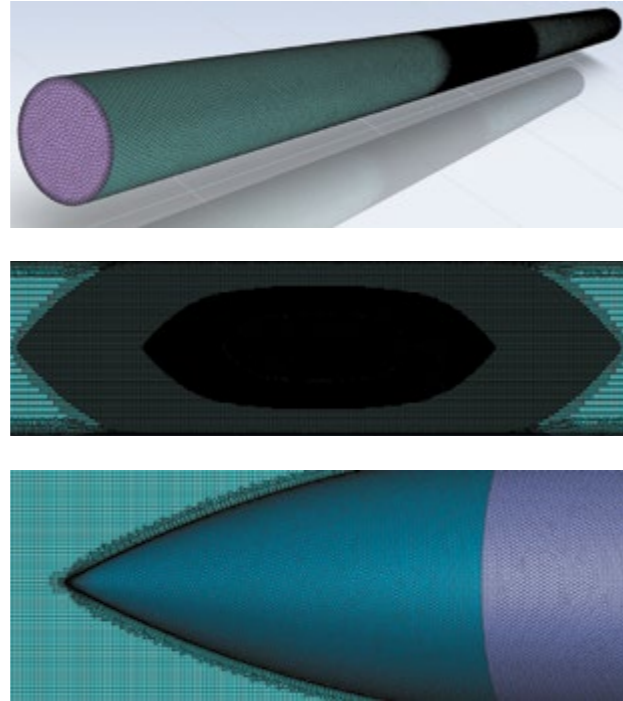

Figure 3 – Finite element model

Results of Mathematical Modeling

Results of Mathematical Modeling for Methane Gas Medium

The results of computer modeling of the hypervelocity uPod motion in a forevacuum tunnel in a methane medium are shown in Figures 4–6.

The images of pressure and density distribution of the medium (Figures 5, 6) correspond to the conditions specified for the calculation and do not contradict the results of research in the field of thermogasdynamics.

As it follows from Figure 4, the maximum speed of the medium is reached between the inner wall of the forevacuum tunnel and the fuselage of the hypervelocity uPod. It is 0.751 of Mach number of the methane gas medium for the uPod with a fuselage diameter of 2 m moving in a tunnel with an inner diameter of 5 m and 0.816 of Mach number for the uPod with a fuselage diameter of 2.6 m moving in a tunnel with an inner diameter of 6 m.

Since the flow speed of the gas medium in the cross section did not exceed 1 Mach, it can be concluded that the flow blockage did not occur, respectively, the subsequent progressive compaction of the medium in the area of the front fairing of the hypervelocity uPod will not occur.

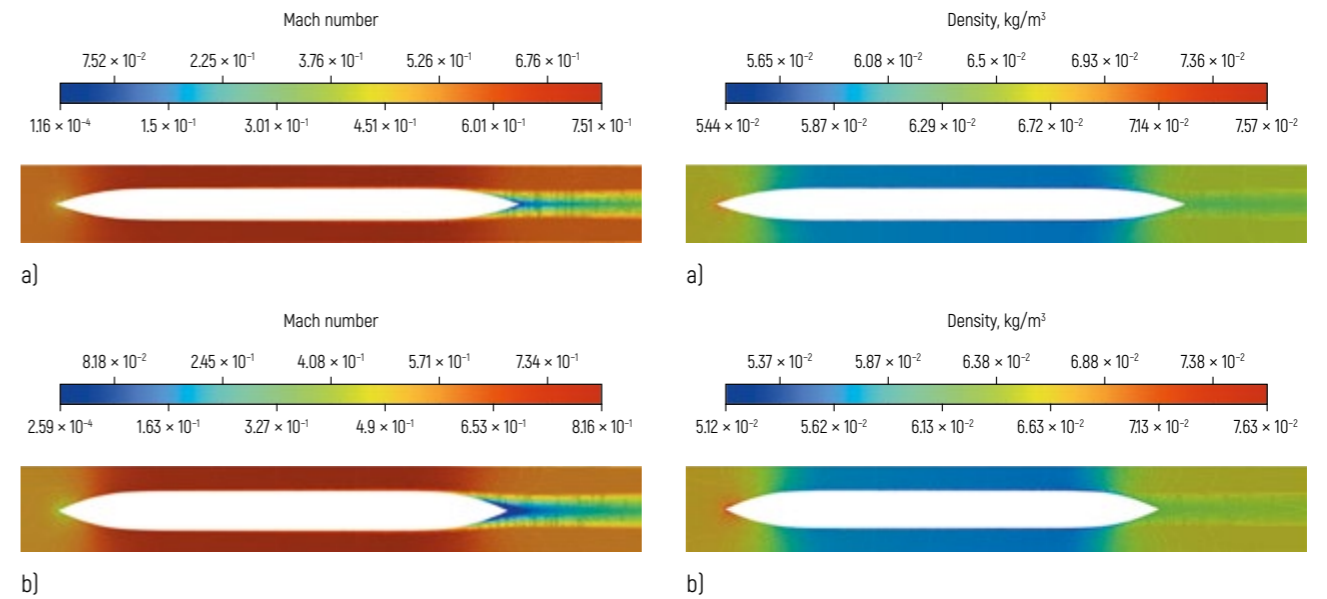

Figure 4 – Distribution of Mach number of methane gas medium in a forevacuum tunnel:
a – for uPod fuselage diameter of 2 m and tunnel inner diameter of 5 m;
b – for uPod fuselage diameter of 2.6 m and tunnel inner diameter of 6 m

Figure 6 – Distribution of methane gas medium density in a forevacuum tunnel:
a – for uPod fuselage diameter of 2 m and tunnel inner diameter of 5 m;
b – for uPod fuselage diameter of 2.6 m and tunnel inner diameter of 6 m

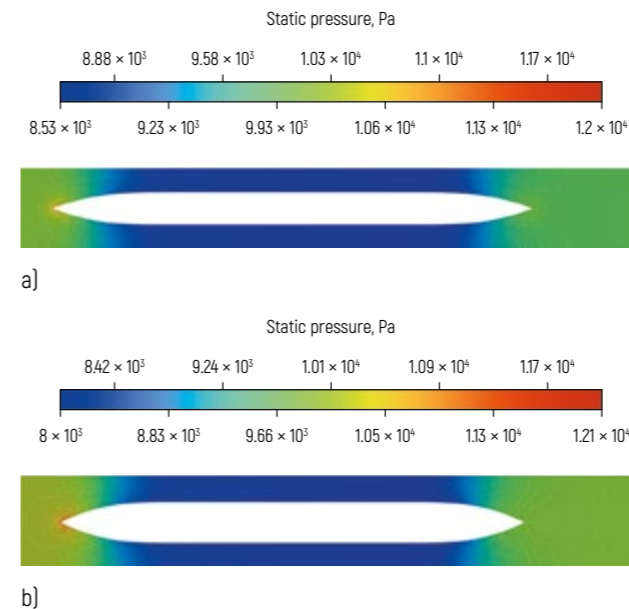

Figure 5 – Distribution of pressure in the volume of methane gas medium:
a – for uPod fuselage diameter of 2 m and tunnel inner diameter of 5 m;
b – for uPod fuselage diameter of 2.6 m and tunnel inner diameter of 6 m

Based on the value of the frontal drag force obtained in the calculation, the total aerodynamic drag coefficient of the uPod was calculated as well as its components on frontal pressure and friction along the entire fuselage surface. As a result, the power required to overcome the total aerodynamic drag in a rarefied methane medium was determined (Table 7).

Table 7 – Aerodynamic characteristics of the uPod when traveling in a forevacuum tunnel at 900 km/h speed in a methane medium at a pressure of 75 mm Hg

uPod fuselage diameter, m	Tunnel inner diameter, m	Frontal drag force F, N	Aerodynamic drag coefficient C_x			Power required to overcome aerodynamic drag, kW
			total	from pressure	from friction	
2	5	1,663	0.257	0.096	0.161	416
2.6	6	2,848	0.26	0.127	0.133	712

Similarly, mathematical modeling was conducted for air and oxygen in order to assess the energy efficiency of the gas used. The principle of constant ratio of the uPod midsection area to the internal cross-sectional area of the forevacuum tunnel was retained.

Results of Mathematical Modeling for Air Gas Medium

The results of the mathematical modeling for the air medium are displayed in Figures 7–9.

As it follows from Figure 7, the maximum speed of the medium is reached between the inner wall of the forevacuum tunnel and the fuselage of the hypervelocity uPod. It is 1.41 of Mach number of the air gas medium for the uPod with a fuselage diameter of 2 m moving in a tunnel with an inner diameter of 5 m and 1.51 of Mach number for the uPod with a fuselage diameter of 2.6 m moving in a tunnel with an inner diameter of 6 m. Since the flow velocity of the gas medium in the cross section exceeded 1 Mach, it can be concluded that gas flow blockage occurs; accordingly, there appears a progressive compaction of the air medium in the area of the front fairing of the hypervelocity uPod.

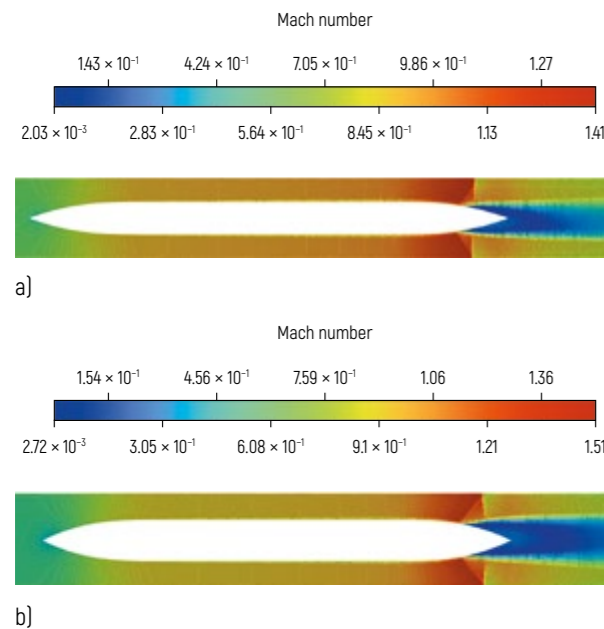

Figure 7 – Distribution of Mach number of air gas medium in a forevacuum tunnel:
a – for uPod fuselage diameter of 2 m and tunnel inner diameter of 5 m;
b – for uPod fuselage diameter of 2.6 m and tunnel inner diameter of 6 m

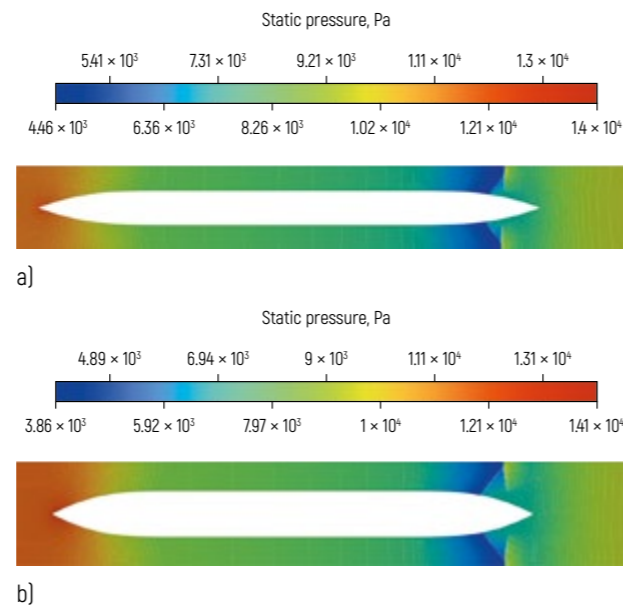

Figure 8 – Distribution of pressure in the volume of air gas medium:
a – for uPod fuselage diameter of 2 m and tunnel inner diameter of 5 m;
b – for uPod fuselage diameter of 2.6 m and tunnel inner diameter of 6 m

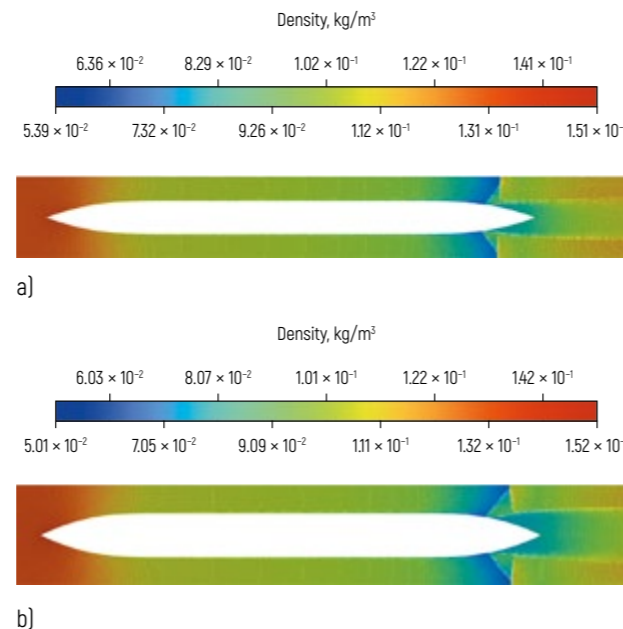

Figure 9 – Distribution of air gas medium density in a forevacuum tunnel:
a – for uPod fuselage diameter of 2 m and tunnel inner diameter of 5 m;
b – for uPod fuselage diameter of 2.6 m and tunnel inner diameter of 6 m

Based on the value of the frontal drag force obtained as a result of the calculation, the total aerodynamic drag coefficient of the uPod and the power required to overcome aerodynamic drag in a rarefied air medium are determined (Table 8).

Table 8 – Aerodynamic characteristics of the uPod when traveling in a forevacuum tunnel at 900 km/h speed in an air medium at a pressure of 75 mm Hg

uPod fuselage diameter, m	Tunnel inner diameter, m	Frontal drag force F, N	Aerodynamic drag coefficient C_x			Power required to overcome aerodynamic drag, kW
			total	from pressure	from friction	
2	5	12,733	1.09	0.95	0.14	3,183
2.6	6	23,805	1.2	1.09	0.11	5,951

The calculation for air medium showed that replacement of methane with air (at the same pressure of 75 mm Hg) increases the power required to overcome aerodynamic drag by about eight times. The main reason for its increase: the air medium has a gas velocity in the cross section between the uPod fuselage and the inner wall of the forevacuum tunnel reached 1 Mach, which led to a progressive increase in pressure in the front fairing area.

An additional factor leading to an increase in drag forces is the molar mass of the gas. Air has a higher molar mass than methane, hence the medium of motion is denser. It should be pointed out that when moving in the air medium in a tunnel of larger diameter, the value of C_x has increased. This increase is due to the strengthening of the ground effect, since the ratio of the cross-sectional area (midsection) of the hypervelocity uPod to the passage area of the tunnel internal cross section has changed by 3 %.

Results of Mathematical Modeling for Oxygen Gas Medium

The simulation results of the hypervelocity uPod movement in oxygen medium are similar to the simulation results for air medium as well as the distribution images of speed, pressure and density of the gas medium.

The maximum speed of the medium is reached between the inner wall of the forevacuum tunnel and the fuselage

of the hypervelocity uPod. It is 1.55 of Mach number of the oxygen gas medium for the uPod with a fuselage diameter of 2 m moving in a tunnel with an inner diameter of 5 m and 1.64 of Mach number for the uPod with a fuselage diameter of 2.6 m moving in a tunnel with an inner diameter of 6 m. Since the flow velocity of the gas medium in the cross section exceeded 1 Mach, it can be concluded that there appears a gas flow blockage; accordingly, there occurs a progressive compaction of the oxygen medium in the area of the front fairing of the hypervelocity uPod.

The total aerodynamic drag coefficient of the uPod and the power required to overcome aerodynamic drag in the oxygen medium were determined based on the value of the frontal drag force obtained as a result of the calculation (Table 9).

Table 9 – Aerodynamic characteristics of the uPod when traveling in a forevacuum tunnel at 900 km/h speed in an oxygen medium at a pressure of 75 mm Hg

uPod fuselage diameter, m	Tunnel inner diameter, m	Frontal drag force F, N	Aerodynamic drag coefficient C_x			Power required to overcome aerodynamic drag, kW
			total	from pressure	from friction	
2	5	17,016	1.32	1.18	0.14	4,254
2.6	6	30,127	1.38	1.27	0.11	7,531

The calculation for oxygen medium showed that replacement of methane with oxygen (at the same pressure of 75 mm Hg) increases the power required to overcome aerodynamic drag by about 10 times. The main reason for the increase: in oxygen, the gas speed in the cross section between the uPod fuselage and the inner wall of the forevacuum tunnel reached 1 Mach, resulting in a progressive increase of pressure in the front fairing area. An additional factor leading to an increase in drag forces is the molar mass of the gas.

Oxygen has a higher molar mass than methane, hence, the medium of motion is denser. It should be pointed out that when moving in the oxygen medium in a tunnel of larger diameter, the value of C_x has increased. This increase is due to the strengthening of the ground effect, since the ratio

of the cross-sectional area (midsection) of the hypervelocity uPod to the passage area of the tunnel internal cross section has changed by 3%.

Assessment of the Energy Efficiency of Aerodynamics in a Methane Tunnel Compared to Long-Haul Aviation

The hypervelocity uPod is unique in terms of speed, comfort and safety when traveling in a forevacuum tunnel with a methane medium. Only an airplane is a similar mode of transport in terms of the set of the abovementioned components. For this reason, the uPod can be compared to modern business jets with fuselage diameters from 1.6 to 2.8 m and fuselage lengths from 25 to 38 m.

Vehicle parameters (Table 10) using the example of one of the most common aircraft series in aviation – Boeing 737 – have been analyzed. There are many versions, so the most popular model for mass passenger flights Boeing 737-800 and a luxury version for business flights Boeing BBJ MAX 9 have been considered.

Since in this study only the power required to overcome aerodynamic drag was determined, the power required to rolling resistance of a steel wheel on the rail and the power consumed for operation of the uPod's internal systems were added for comparative analysis of parameters of power units in the uPods.

Table 10 clearly demonstrates the energy efficiency of the uPod passenger transportation. Despite the fact that

both modes of transport move in a rarefied medium (the uPod – in a methane forevacuum tunnel, the airplane – at an altitude above 10 km), the airplane has an incomparably larger cross-sectional area (including wings), imperfect aerodynamics due to the presence of wings with turboprops installed on them and the tail part of the fuselage. In addition, a significant amount of energy is used to keep the aircraft in the air, while the uPod requires no energy at all to maintain a stable position, as it is supported by steel wheels on the track structure. Together with energy efficiency, the cost of transport should also be taken into account: if the uPod is mass produced, it will not exceed 8 mln USD, which is over 13 times cheaper than Boeing 737-800.

Conclusion

The use of methane as the working medium of the forevacuum tunnel will allow the uPod to move at a speed of 900 km/h and more, whereas energy consumption will be significantly lower than in air or oxygen medium at the same diameter of the forevacuum tunnel.

Replacement of methane gas medium with air medium in a 6 m diameter tunnel will result in 84 times increase of power required to overcome aerodynamics, and in case of replacement with oxygen the required power will increase by 10.6 times. Calculations have established that for the uPod to move at a speed of 900 km/h without flow blockage in a methane medium, the tunnel diameter can be 2.1 times smaller than in an air medium or 2.9 times smaller than in an oxygen medium.

Thus, the use of methane will allow to reduce the overall dimensions and weight per linear meter of the entire transport infrastructure of the GPV equatorial overpass. Lightening of the linear section will lead to a reduction in the material intensity of its other components: supporting towers, foundations, anchoring structures and stations. Significant savings will be achieved when passing through challenging natural areas, such as mountains, ravines and water obstacles.

A comparative assessment of energy efficiency of passenger transportation by the uPod and long-haul aviation showed that transportation of one passenger by the uPod at a speed of 900 km/h requires 9.7 times less power (12.5 kW·h/passenger vs. 121.5 kW·h/passenger) than for an economy-class airplane.

In addition to the obvious aerodynamic advantages, the presence of methane in the forevacuum tube will provide the fuel reserve necessary for the operation of a gas turbine power unit or a compact gas turbine engine that generates electricity for all main and auxiliary systems. Consequently, the uPod must carry oxidizer (oxygen) rather than fuel, as the fuel will be the gas medium of the forevacuum tunnel. As it is consumed, methane will be fed in the needed amount from one end of the tunnel, and combustion products (H₂O and CO₂) will be discharged from its other end. At the same travel speeds as in aviation, a methane tunnel is environmentally cleaner and safer, because the more environmentally friendly fuel (methane) will be burned in an isolated and enclosed tunnel volume. Toxic aviation kerosene, and in much larger relative quantities, is burned in an airplane turbine in the most vulnerable lower layers of the stratosphere, creating an inversion trail and destroying the planet's protective ozone layer.

In addition, transport safety will be significantly improved, as the movement of the uPod in the tunnel is not affected by negative external natural, climatic and other impacts (rain, snow, hail, icing, fog, dust storm, wind, clouds, birds, lightning strike, etc.) as well as technical factors caused by design features of the vehicle or human errors (engine stalled, fuel ran out, landing gear failed, landing past the runway occurred, insufficient runway length, tire burst, collision with a snowplow or other machinery, etc.).

Further research is planned to focus on finding the preferred pressure of the gas medium, determining the optimal parameters of the forevacuum tunnel and ways to use methane as an energy source for the power unit mounted on the chassis of the hypervelocity uPod.

References

1. *Unitsky, A.E. Transportnyye sistemy "vtorogo urovnya": sovremennoye sostoyaniye i perspektivy razvitiya [Transport Systems of the Second Level: Current State and Prospects of Development] / A.E. Unitsky, S.V. Artyushevskiy, D.I. Bochkarov // Gornaya mekhanika i mashinostroyeniye. – 2022. – No. 4. – P. 39–56.*
2. *Sonkar, A. Spaceborne SAR-Based Detection of Ships in Suez Gulf to Analyze the Maritime Traffic Jam Caused Due to the Blockage of Egypt's Suez Canal / A. Sonkar, S. Kumar, N. Kumar // Sustainability. – 2023. – Vol. 15. – 9706.*
3. *Unitsky, A.E. Tekhnosfera 2.1 – perezagruzka zemnoy industrii na kosmicheskiy vektor razvitiya [Technosphere 2.1 – Rebooting Earth's Industry to the Cosmic Vector of Development] / A.E. Unitsky // Bezzaketnaya industrializatsiya blizhnego kosmosa: problemy, idei, proyekty: Collection of Articles of the III International Scientific and Technical Conference, Maryina Gorka, Sep. 12, 2020 / Astroengineering Technologies LLC, Unitsky String Technologies Inc.; ed. A.E. Unitsky. – Minsk: SroyMediaProyekt, 2021. – P. 36–73.*
4. *Transportnaya nedelya – 2022 [Transport Week 2022] // Mir transporta. – 2022. – Vol. 20, No. 6 (103). – P. 36–55.*
5. *Yavuz, M.N. Comparison of Conventional High Speed Railway, Maglev and Hyperloop Transportation Systems / M.N. Yavuz, Z. Öztürk // International Advanced Researches and Engineering Journal. – 2021. – Vol. 5, iss. 1. – P. 113–122.*
6. *Impact of Vacuum Degree on the Aerodynamics of a High-Speed Train Capsule Running in a Tube / Y. Sui [et al.] // International Journal of Heat and Fluid Flow. – 2021. – Vol. 88. – 108752.*
7. *Optimal Setting of Air Shafts for Subway Tunnel Based on Piston Effect / C. Chen [et al.] // China Railway Science. – 2015. – Vol. 6. – P. 70–77.*
8. *Bizzozero, M. Aerodynamic Study of a Hyperloop Pod Equipped with Compressor to Overcome the Kantrowitz Limit / M. Bizzozero, Y. Sato, M.A. Sayed // Journal of Wind Engineering and Industrial Aerodynamics. – 2021. – Vol. 218. – 104784.*
9. *Ota, M. New Frontier of Engineering and Science Fields Pried by Arthur R. Kantrowitz / M. Ota // The Proceedings of Mechanical Engineering Congress, Japan. – 2016. – Vol. 2016. – S2010105.*
10. *Anderson, J.D. Fundamentals of Aerodynamics / J.D. Anderson. – New York: McGraw-Hill Education, 2016. – 1154 p.*

Table 10 – Comparative characteristics of the uPods and popular aircraft models used in long-haul aviation

Parameter	uPod uMach-2*	uPod uMach-2.6*	Boeing 737-800	Boeing BBJ MAX 9
Cabin length, m	20	20	29.9	32.7
Cabin width, m	1.8	2.3	3.54	3.18
Passenger capacity, persons	46	80	189	50
Cruising speed, km/h	900	900	842	842
Power unit capacity at cruising speed, kW	650	1,000	22,900	22,900
Power consumed per one passenger, kW·h/passenger	14.3	12.5	121.5	458.4
Estimated cost, mln USD	6	8	106.1	128.9

* The uMach-2 model corresponds to the uPod with a fuselage diameter of 2 m, the uMach-2.6 model corresponds to a uPod with a fuselage diameter of 2.6 m.

11. Kogan, M.N. *Dinamika razrezhonnogo gaza. Kineticheskaya teoriya [Dynamics of Rarefied Gas. Kinetic Theory]* / M.N. Kogan. – Moscow: Nauka, 1967. – 440 p.
12. Ganeshan, K. *Finite Element Discrete Boltzmann Method for High Knudsen Number Flows [Electronic resource]* / K. Ganeshan, D. Williams. – Mode of access: https://www.researchgate.net/publication/347965068_A_finite_element_discrete_boltzmann_method_for_high_knudsen_number_flows. – Date of access: 20.09.2023.
13. *Knudsen Number Sensitivity to Pressure Drop in a Nanoscale Membrane [Electronic resource]* / M.M. Ramalan [et al.]. – Mode of access: https://www.researchgate.net/publication/367336464_Knudsen_Number_Sensitivity_to_Pressure_Drop_in_a_Nanoscale_Membrane. – Date of access: 20.09.2023.
14. Landau, L.D. *Mekhanika sploshnykh sred [Mechanics of Continuous Medium]* / L.D. Landau, Ye.M. Lifshits. – 2nd ed., revised and supplemented. – Moscow: Gosudarstvennoye izdatel'stvo tekhniko-teoreticheskoy literatury, 1953. – 788 p.
15. *Post Flight Aerodynamic Analysis of the Experimental Vehicle PRORA USV 1 [Electronic resource]* / G. Rufolo [et al.] // 15th AIAA International Space Planes and Hypersonic Systems and Technologies Conference, Dayton, Ohio, 28 Apr. – 1 May 2008. – Reston: American Institute of Aeronautics and Astronautics, Inc., 2008. – Mode of access: https://www.researchgate.net/publication/260861667_Post_Flight_Aerodynamic_Analysis_of_the_Experimental_Vehicle_PRORA_USV_1. – Date of access: 20.09.2023.
16. *Numerical Analysis of Aerodynamic Characteristics of Hyperloop System* / J.S. Oh [et al.] // *Energies*. – 2019. – Vol. 12, iss. 3. – 518.

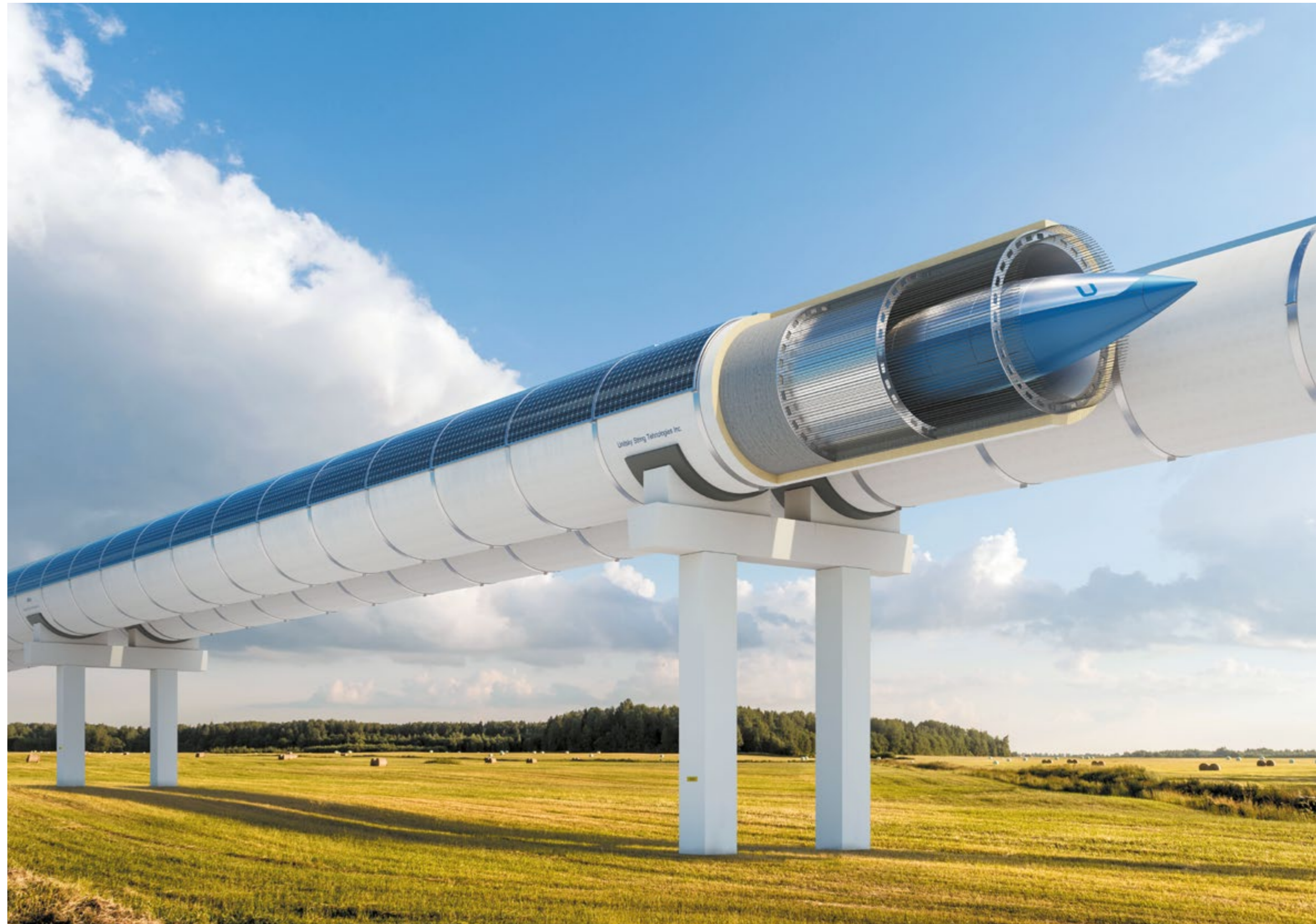

Metal Foam Based Protection of the General Planetary Vehicle Body Against Meteoroids

A. Unitsky^{1,2}
Dr. of Philosophy
in Information Technologies
(Transport)

V. Ausianka²

¹ Astroengineering Technologies LLC,
Minsk, Belarus

² Unitsky String Technologies Inc.,
Minsk, Belarus



The high level of human activity in space has resulted in the contamination of the near-Earth environment, that is dangerous in the case of new spacecraft launch. The annual increase of their size and quantity in orbit only exacerbates the existing problem. Today, the spacecraft construction includes special shields to protect them against space debris. This article presents results of the numerical modeling of the General Planetary Vehicle (GPV) protection against impact of meteoroid and technogenic particles. The modeling has been carried out in ANSYS/LS-DYNA program with the use of combined approach, including Lagrange method and smoothed particle hydrodynamics (SPH). To obtain a more valid assessment, the model of open cell structure of the main energy-absorbing element made of foam aluminum is performed with detailed study of the geometry considering the size of cells and pores as well as fiber thickness. On the basis of the performed modeling, the option of the shield protecting the GPV body against particles up to 5 mm is provided.

Keywords:

finite element method, General Planetary Vehicle (GPV), high-speed impacts, numerical modeling, protection against meteoroids, smoothed particle hydrodynamics (SPH).

Introduction

For successful and long-term operation of the General Planetary Vehicle (GPV) [1], it is necessary to pay attention as early as at the designing stage to the protection of the body from the high-speed impact effect of meteoroids and anthropogenic debris, the amount of which is constantly growing in Earth's orbits.

The options of GPV body protection in case of collision with various space debris fragments are considered in [2]. Thus, to prevent damage from meteoroids of 5 mm in size, composite protection is proposed, which includes:

- a barrier, that is two rows of steel mesh with a cell gap of 1 mm;
- the main energy-absorbing element, that is foam aluminum with a structure of 40 pores per inch (40 ppi) enclosed between aluminum plates (1 mm thick front one and 2 mm thick rear one).

At the same time, it is shown that about 48 mm of foam aluminum is needed to stop a meteoroid having a diameter of 5 mm and moving at a speed of 8 km/s. All elements of the protection structure are represented by volumetric finite elements (FEs), and the Lagrange method is chosen for modeling. This formulation is simplified and can be used at the initial stages of modeling, when it is required to conduct an evaluative comparative analysis of different body protection design options within a limited time frame.

The modeling of foam aluminum by the continuum method does not take into account the processes of propagation, re-reflection and superposition of shock waves in the lintels of the material, which introduces a significant error in the calculation results. In addition, the continuum model does not include pores, therefore, small fragments cannot reach the rear wall unhindered, thus reducing the load on it. In order to obtain the most realistic behavior of foam materials in a high-speed collision, it is necessary to use a model that adequately enough reflects the foam microstructure.

Consequently, in this article it is proposed the application of a model that has an increased level of detailing the open cell structure of foam aluminum.

Making a Foam Aluminum Model

An example of Duocell foam aluminum sample from ERG Aerospace, which has open pores [3], is shown in Figure 1. The spatial structure of foam aluminum is characterized

by a minimum fiber surface [4] and can be described by Kelvin or Weaire-Phelan cells. The Kelvin cells represent a tetrakaidekahedron consisting of eight facets of regular hexagonal shape and six square facets (Figure 2a). The Weaire-Phelan foam differs from the Kelvin structure in that it utilizes two types of cells having equal volume: a pyriothedron and a tetrakaidekahedron (Figure 2b).

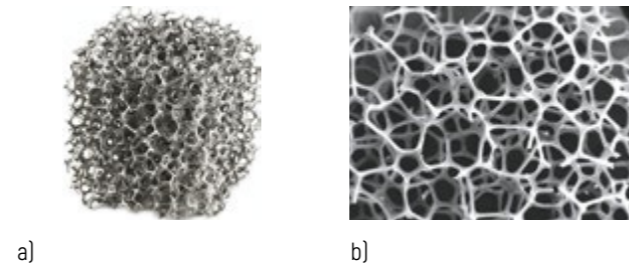

Figure 1 – Duocell foam aluminum with 40 ppi porosity: a – sample; b – microscope view

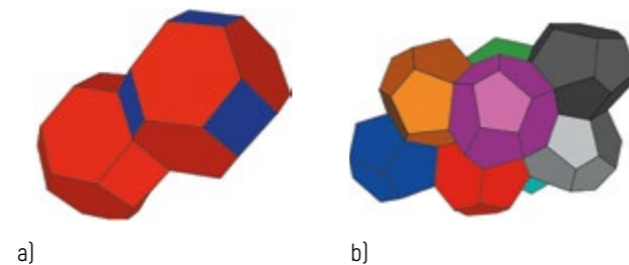

Figure 2 – Foam structure: a – Kelvin foam cells; b – Weaire-Phelan foam cells

The surface area of the Weaire-Phelan structure is 0.3% smaller than that of the Kelvin structure, but the Kelvin cell is easier to construct and scale. Therefore, the geometric model of foam based on Kelvin cells was used for the research.

The foam structure is characterized by three main parameters: cell size d_c , pore diameter d_p and average fiber (lintel) size t , (Figure 3). The formation of the geometrical model of the foam is performed by subtracting a sphere from a tetrakaidekahedron. The diameter of the sphere d_s is set in such a way as to provide the necessary pore and cell sizes.

The size and shape of the foam aluminum cell lintel determine the strength of the composite material: under static compression, the load is transmitted through the fiber,

and under high-speed dynamic loading, shock waves spread through the fibers. The real lintel is inhomogeneous in thickness, its cross section is an open shell (Figure 4). In modeling, the lintel is constructed as a volumetric body. According to [5], this approach does not introduce a significant error in the accuracy of the results.

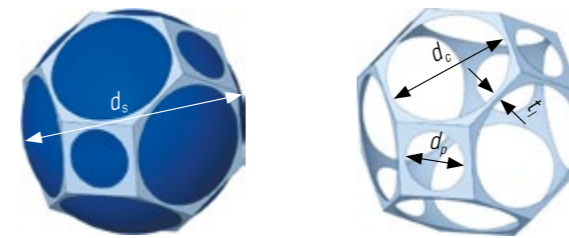

Figure 3 – Geometrical model of foam

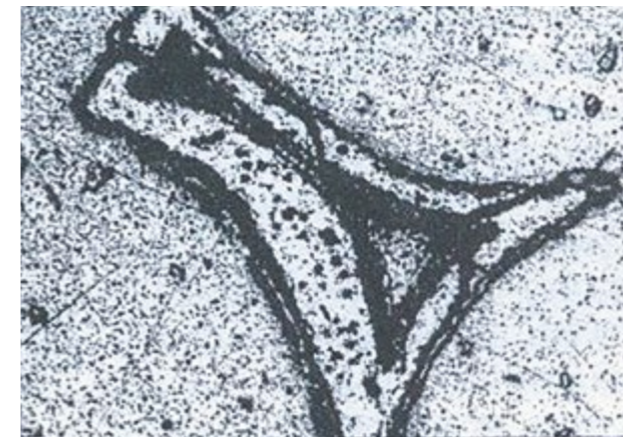

Figure 4 – Cross section of the foam aluminum lintel

The parameter that has the greatest effect on the mechanical strength of foam aluminum in modeling high-speed interaction with an obstacle is the porosity P , which reflects the amount of material in the composite [5]:

$$P = 1 - \frac{\rho}{\rho_s},$$

where P – porosity;

ρ – foam material density;

ρ_s – density of the foam material (aluminum).

The geometrical characteristics of the foam aluminum structure having different number of pores per unit length and relative density of 6–8% are summarized in Table 1 [6].

Table 1 – Geometrical characteristics of foam aluminum structure

Porosity, ppi	Cell size, mm	Pore diameter, mm	Fiber thickness, mm
10	3.95	2.33	0.382
20	3.28	1.78	0.329
40	2.63	1.59	0.251

HEX volumetric eight-node elements are used to construct the mesh. The size of the foam structure fibers is adjusted by scaling the internal edges of the FE model relatively to the center of the cell. Next, an array of the required size is constructed from the FE model of a single foam cell. The final view of the foam aluminum model with 40 ppi porosity is shown in Figure 5.

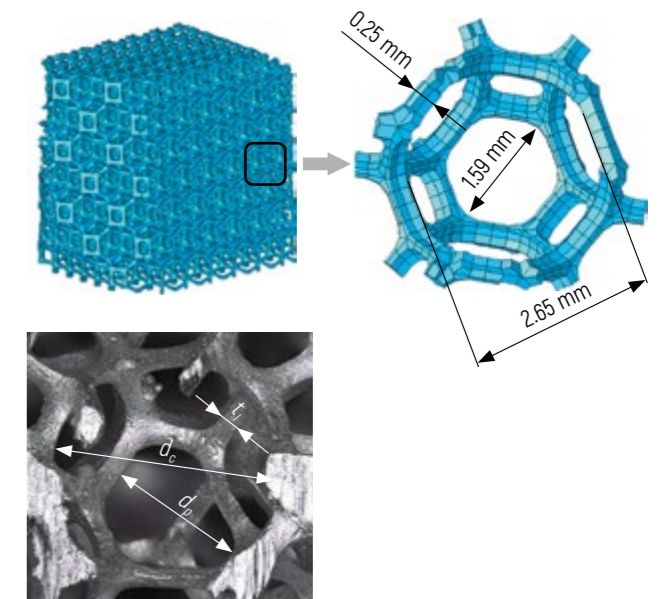

Figure 5 – Finite element model of foam aluminum with 40 ppi porosity

Verification of the Foam Aluminum Model

In computer modeling of complex physical processes, a mandatory stage is the verification of the developed computational model, for which it is proposed to use data from field experiments [6] that were conducted by a group of NASA scientists at the White Sands test site, which is part of the Johnson Space Center. The tests were carried out

on a two-stage light-gas accelerator (Figure 6) with a caliber of 0.5 inch, allowing to accelerate projectiles up to a velocity of 8.5 km/s.



Figure 6 – General view of the light-gas accelerator

Technogenic space debris are fragments of failed spacecraft, the main material of which is aluminum alloys. At the same time, about 90 % of meteorites reaching the Earth's surface are of stone meteorite group type – chondrites [7]. According to [8], the density of chondrites is about 3 g/cm³, which approximately corresponds to the density of aluminum alloys. Consequently, a sphere made of 2017-T4 aluminum alloy (density 2.78 g/cm³) was used as a puncher for field tests.

From the catalog of field tests of the Hypervelocity Impact Technology Center (USA), experiment number HITF-08263 was selected, which is the closest in terms of the interaction speed of the puncher (6.52 km/s) to the puncher speed of the computational experiment (8 km/s). The front and rear panels of the protective structure were made of 6061-T6 aluminum alloy sheets having thicknesses of 0.254 mm and 0.508 mm respectively. The gap between the panels was filled with foam aluminum with a porosity of 40 ppi, the relative density of which is about 7 %.

The diagram of the field experiment and the corresponding computational model developed in ANSYS/LS-DYNA package is shown in Figure 7.

The main material parameters of the Johnson-Cook model and the Mie-Grüneisen equation of state [9] used in the computational model are summarized in Table 2.

In the process of numerical experiments, the location of the foam material model relatively to the direction of motion of the puncher was noted to be of significant importance.

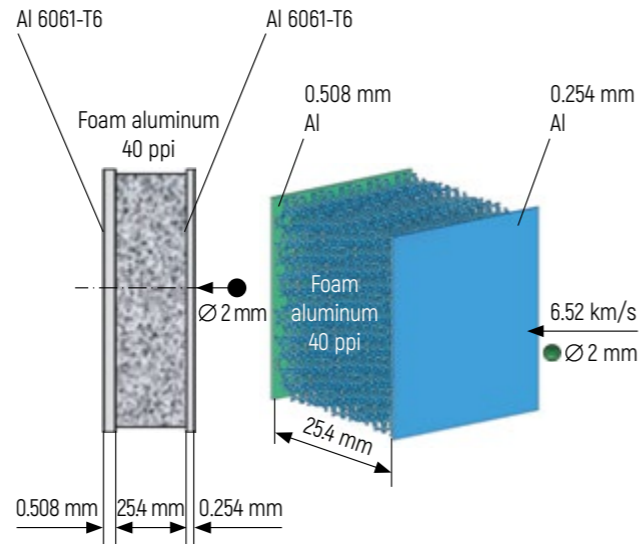

Figure 7 – Diagram and model of the HITF-08263 experiment on penetration of the protective panel

Table 2 – Material parameters of the Johnson-Cook model and the Mie-Grüneisen equation of state

Parameter, unit of measurement	2017-T4 aluminum alloy	6061-T6 aluminum alloy
Johnson-Cook model		
Density, kg/m ³	2,780	2,703
Poisson's ratio	0.33	0.33
Modulus of elasticity, MPa	73,100	70,000
Yield strength, MPa	369	324
Strain hardening modulus, MPa	684	114
Strain hardening index	0.73	0.42
Coefficient for strain rate	0.0083	0.002
Damage accumulation parameter 1	9	9
Damage accumulation parameters 2-5	0	0
Mie-Grüneisen equation of state		
Curve slope coefficient C	5,328	5,240
Curve slope coefficient S_1	1.338	14
Coefficient γ	2	1.97

When constructing the array of cells, the structure of the foam material is formed in an ordered manner along the axes of copying elements, which should be taken into account in modeling. Thus, when the puncher moves along the normal to the hexagonal facet of the tetrakaidekahedron (Figure 8a), areas (tunnels) appear in the model, within which fragments of the puncher and destroyed foam aluminum can freely reach the rear wall of the protective structure, and fragments moving at a small angle to the normal of the facet, reflecting from the fibers of the cells, return to the tunnel. A similar situation, but to a lesser extent, is observed when the square facet of the tetrakaidekahedron is positioned normal to the direction of motion (Figure 8b). As can be seen from Figure 1, the arrangement of the fibers of the real foam material cells is arbitrary, so the model should be turned by the angle at which there will be no gaps in the structure (Figure 8c).

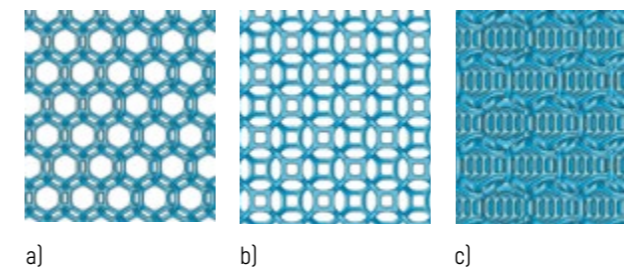

Figure 8 – Location of the foam aluminum model cells in relation to the direction of puncher motion: a – located lengthwise; b – turned by 90°; c – turned by an angle that excludes gaps in the structure

Verification of the model is carried out by comparing the results of the field experiment and numerical modeling. In the field experiment, the front panel is penetrated and the foam aluminum destruction is about 80 % of the material thickness (Figure 9). The rear wall has bulges and a puncture of less than 1 mm.

Figure 10 shows the results of the modeling: the front panel is penetrated, and the size of the hole is 5–6 times more than the size of the puncher; the rear wall of the protective structure remained practically undamaged, only individual dents and bulges are observed.

As can be seen from Figures 9 and 10, the results of numerical modeling and field experiment correspond, which indicates the adequacy of the developed model and the possibility of its application for further research of the GPV body protective shield.

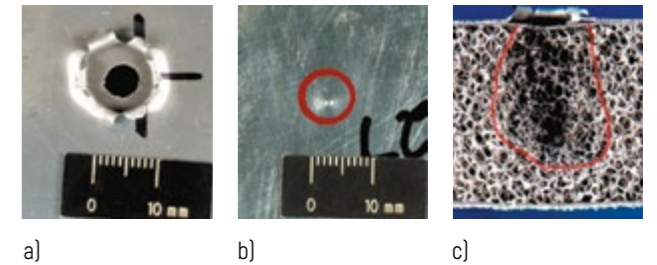

Figure 9 – Results of the HITF-08263 field experiment on penetration of the protective panel: a – front wall; b – rear wall; c – foam aluminum

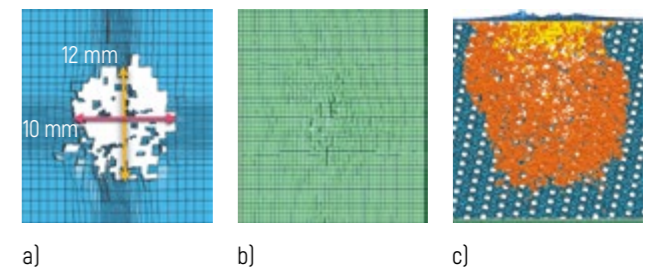

Figure 10 – Results of the computational experiment on penetration of the protective panel: a – front wall; b – rear wall; c – foam aluminum

Description of the GPV Body Protection Model Against Meteoroids of 5 mm Size

In order to reduce the mass of protective shields, a metal mesh is often used as an outer layer. An example is the protection of the functional cargo unit at the International Space Station [10].

In [11], various options of mesh anti-meteoroid shields were studied. Based on the calculations and field experiments, the researchers noted a significant improvement in the protective properties of mesh shields characterized by a cascade arrangement of corrugated meshes compared to conventional meshes of the same mass. According to the conclusions presented in [11], the protection design described in [2] has been modified. Two rows of corrugated mesh (45° angle) with different cell size are proposed as a barrier for the anti-meteoroid protection under development. The first layer of protection is a coarse mesh (1.8 mm pitch, 1 mm gap, 0.8 mm wire diameter); the second layer of barrier protection is a fine mesh (0.9 mm pitch, 0.4 mm gap, 0.5 mm wire diameter). The height of the corrugation is 5 mm.

The calculations were performed through the ANSYS/LS-DYNA software package. Due to the presence of large deformations and damages in the model, a meshless calculation method was chosen, the main task of which is to solve integral equations or partial differential equations without the use of reference to the nodes of the FE mesh. The most popular methods for calculating a high-speed impact with destruction are smoothed particle hydrodynamics (SPH) [12] and smoothed particle Galerkin (SPG) methods [13]. The latter method was developed later. It is successfully applied for modeling the destruction of plastic and low-plastic materials and also allows to cope with the problems of tensile instability that are inherent in the SPH method [14]. However, as the experience of solving anti-meteoroid protection problems [15, 16] has shown, the SPG method is less accurate than FE modeling by the Lagrange method together with the SPH method.

Thus, the authors of this research have chosen the Lagrange and SPH methods to model the protection of the GPV body from meteoroids. The Johnson-Cook model with the Mie-Grüneisen equation of state are taken to describe the behavior of materials. The average size of the FE mesh of the foam aluminum model is 0.12 mm. The SPH method, especially for fine element partitioning, requires significant computational cost, therefore, two planes of symmetry (XY and YZ) are used in the model to increase the calculation efficiency. The general view of the computational model of the protective shield (with symmetry display enabled) is shown in Figure 11.

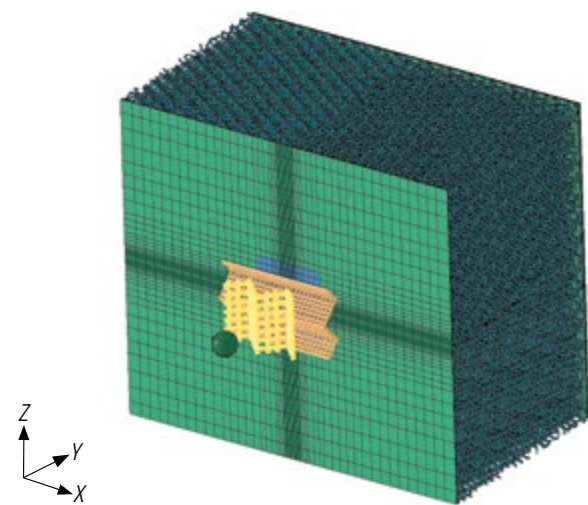

Figure 11 – Computational model of the GPV body protective structure

The thickness of the front plate made of 6061-T6 aluminum alloy is 1 mm, the thickness of the rear wall is 2 mm. A layer of foam aluminum with porosity of 40 ppi and thickness of 45 mm is assumed as the main energy-absorbing material.

Results of Numerical Modeling of the GPV Body Protection

The results of modeling the penetration of the GPV body anti-meteoroid protection by a sphere with a diameter of 5 mm and an initial velocity of 8 km/s are shown in Figures 12–15. For clarity, the foam aluminum elements destroyed during the calculation process are returned into the model and marked in brown (Figure 12).

When hit by a spherical puncher, the width of the foam panel fracture zone in its wide part is approximately four times larger than the size of the puncher (Figure 12). The foam material is destroyed by more than 90 % along the direction of meteoroid motion. The size of the hole in the front wall model is 28.9 mm and 50.3 mm in different projections (Figure 13). This index may be smaller when the panel model is partitioned in detail into FEs.

Figure 14 shows the moment of penetration of two rows of corrugated mesh by an aluminum sphere. The second row has greater damage than the first one. This is explained by the fact that in the process of passing through the first row of the mesh, the aluminum sphere deforms and increases in diameter.

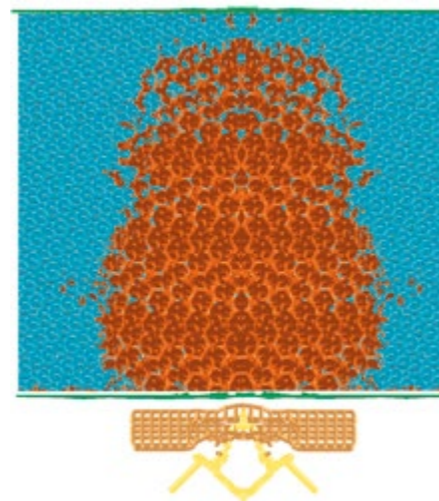

Figure 12 – Results of modeling the GPV body protective structure against a 5 mm meteoroid

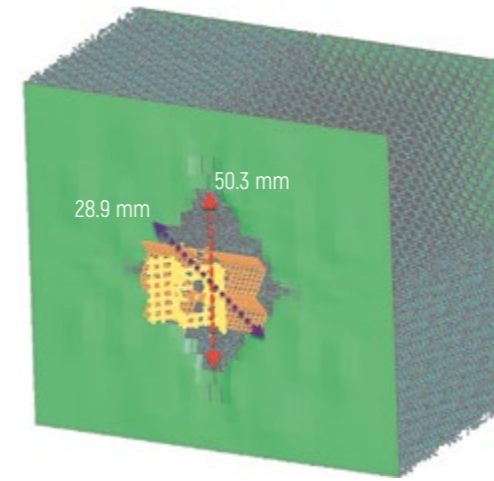

Figure 13 – Destruction of the front panel of the protective structure

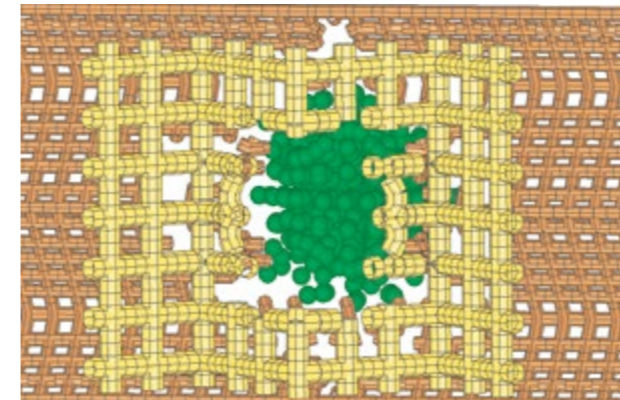

Figure 14 – Destruction of the mesh barrier of the protective structure

Figure 15 shows a graph of the change in velocity of the aluminum sphere during the passage of the anti-meteoroid protection, where an irregular decrease in velocity can be observed.

A reducing from 8 to 7 km/s is recorded when the puncher passes the first mesh barrier (Figure 15, I). The velocity drop continues when passing the second mesh barrier (Figure 15, II). The puncher then hits the outer sheet of aluminum (Figure 15, III). Next, there is a gradual decrease in the velocity of the puncher as it traverses the foam aluminum layer (Figure 15, IV). The entire process of the meteoroid passing through the protective shield until it comes to a complete stop takes 22 μ s.

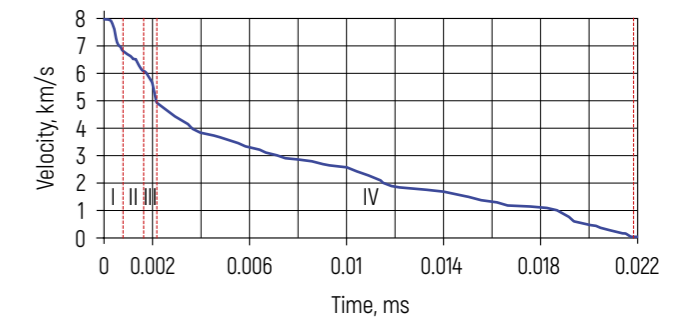

Figure 15 – Graph of the puncher velocity as it passes through the protective structure

The main mass of fragments formed in the process of destroying the protective structure is stopped by foam aluminum (Figure 12). However, some fragments of the destroyed parts of the protection reach the rear wall, which is deformed but not destroyed because the velocity and mass of the particles are insufficient (Figure 16).

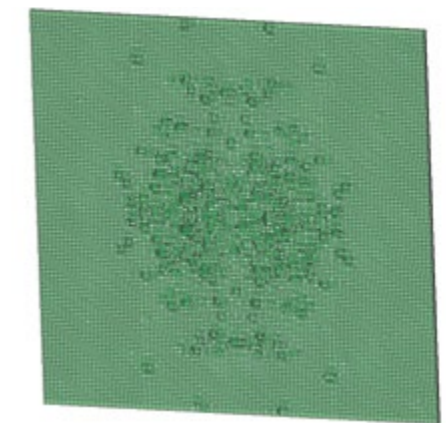

Figure 16 – Damage to the rear panel of the protective structure

Conclusion

This article presents the results of numerical modeling of the GPV body protection against meteoroids of 5 mm in size. Foam aluminum with a porosity of 40 ppi was taken as the main energy-absorbing material. Its model was made with an increased level of structure detailing on the basis of Kelvin cells. Modeling was carried out with the joint application of the SPH method and the finite element Lagrange method. The results of the experiment, performed in the ANSYS/LS-DYNA program, showed that by using two

rows of corrugated metal mesh with different cell size as an external barrier, the total thickness of the anti-meteoroid protection can be reduced by 5 mm compared to the model proposed in [2].

In addition to the improved protective properties, corrugated meshes are quite technologically advanced in terms of manufacturing and installation. Moreover, this construction is characterized by optimal rigidity, which is necessary for retaining the shape and the ability to be attached to the GPV body. Filling the space of corrugations with foam and the presence of limiting surfaces allow to minimize the release into the environment of fragments and debris formed during an impact, which can minimize the contamination of near-Earth space.

As a promising direction for further work to improve the protection of the GPV body from meteoroid impact, the authors consider the use of multilayer spaced barriers made of para-aramid braided fibers.

References

1. Unitsky, A. *String Transport Systems: On Earth and in Space* / A. Unitsky. – Silakrogs: PNB Print, 2019. – 560 p.
2. Unitsky, A. *Protection of the General Planetary Vehicle from Meteoroids and Space Garbage* / A. Unitsky, S. Pronkevich, V. Ausianka // *Non-Rocket Near Space Industrialization: Problems, Ideas, Projects: Collection of Articles of the IV International Scientific and Technical Conference, Maryina Gorka, Sep. 18, 2021 / Astroengineering Technologies LLC, Unitsky String Technologies Inc.; ed. A. Unitsky. – Minsk: StroyMediaProject, 2022. – P. 205–211.*
3. Veale, P.J. *Investigation of the Behavior of Open Cell Aluminum Foam* [Electronic resource] / P.J. Veale. – Mode of access: <https://scholarworks.umass.edu/cgi/viewcontent.cgi?article=1527&context=theses>. – Date of access: 14.07.2023.
4. Mukhamediyev, Sh.A. *Emul'sii i peny: stroyeniye, polucheniye i ustoychivost'* [Emulsions and Foams: Structure, Production and Stability] / Sh.A. Mukhamediyev, V.A. Vas'kina // *Masla i zhiry. – 2008. – No. 10. – P. 22–26.*
5. *Prognozirovaniye fiziko-mekhanicheskikh svoystv VPYAM na osnove strukturnogo modelirovaniya* [Prediction of Physicomechanical Properties of High-Porous Permeable Cell Materials on the Basis of Structural Modeling] / L.D. Sirotenko [et al.] // *Vestnik PNIPU. Mashinostroyeniye, materialovedeniye. – 2010. – Vol. 12, No. 1. – P. 17–29.*
6. *Hypervelocity Impact Performance of Open Cell Foam Core Sandwich Panel Structures* [Electronic resource] / S. Ryan [et al.]. – Mode of access: https://www.researchgate.net/publication/292756529_Hypervelocity_impact_performance_of_open_cell_foam_core_sandwich_panel_structures. – Date of access: 14.07.2023.
7. *Dodd, R.T. Meteorites, a Petrologic-Chemical Synthesis* / R.T. Dodd. – Cambridge: Cambridge University Press, 1981. – 368 p.
8. *Vzaimosvyaz' sostava, struktury i mekhanicheskikh svoystv H5 khondritov na primere NWA 12370 i Pultusk* [Interrelation of Composition, Structure and Mechanical Properties of H5 Chondrites on the Example of NWA 12370 and Pultusk] / V.A. Voropayev [et al.] // *Astronomicheskiiy vestnik. – 2021. – Vol. 55, No. 5. – P. 412–426.*
9. *Aslebagh, R. Hypervelocity Impact on Satellite Sandwich Structures: Development of Simulation Model and Investigation of Projectile Shape and Honeycomb Core Effects* [Electronic resource] / R. Aslebagh. – Mode of access: <https://scholar.uwindsor.ca/cgi/viewcontent.cgi?article=9594&context=etd>. – Date of access: 14.07.2023.
10. *Testirovaniye prototipa zashchity kosmicheskogo apparata ot meteoroidov i chastits orbital'nogo musora* [Testing of a Prototype of Spacecraft Protection Against Meteoroids and Orbital Debris Particles] / L.N. Bezrukov [et al.] // *Mekhanika kompozitsionnykh materialov i konstruktsiy. – 2014. – No. 4. – P. 646–662.*
11. *Ekspiermental'noye issledovaniye stoykosti gofirovannykh setochnykh protivometeornykh ekranov* [Experimental Study of the Resistance of Corrugated Mesh Micrometeoroid/Orbital Debris Shields] / D.B. Dobritza [et al.] // *Vestnik NPO im. S.A. Lavochnika. – 2021. – No. 1 (51). – P. 24–32.*
12. *He, Q.-G. Finite Elements-Smoothed Particle Hydrodynamics Adaptive Method in Simulation Debris Cloud* / Q.-G. He, X. Chen, J.-F. Chen // *Acta Astronautica. – 2020. – Vol. 175. – P. 99–117.*
13. *Wu, Y. Parametric and Convergence Studies of the Smoothed Particle Galerkin (SPG) Method in Semi-Brittle and Ductile Material Failure Analyses* [Electronic resource] / Y. Wu, C.T. Wu, W. Hu. – Mode of access: https://76a9305a-74cf-458e-a064-09a42b4305e9.filesusr.com/ugd/157719_ef08fdf50b964ce581cdf3c7be6ee12d.pdf. – Date of access: 14.07.2023.
14. *Smoothed Particle Galerkin Method with a Momentum-Consistent Smoothing Algorithm for Coupled Thermal-Structural Analysis* [Electronic resource] / X. Pan [et al.]. – Mode of access: https://76a9305a-74cf-458e-a064-09a42b4305e9.filesusr.com/ugd/157719_3c0fa3b6630b4a9caadf36fff25008ee.pdf. – Date of access: 14.07.2023.

[b4305e9.filesusr.com/ugd/157719_3c0fa3b6630b4a9caadf36fff25008ee.pdf](https://76a9305a-74cf-458e-a064-09a42b4305e9.filesusr.com/ugd/157719_3c0fa3b6630b4a9caadf36fff25008ee.pdf). – Date of access: 14.07.2023.

15. *NASA ACC Hight Energy Dynamics Impact Methodology and Outcomes* [Electronic resource] / K.J. Hunziker [et al.]. – Mode of access: <https://ntrs.nasa.gov/api/citations/>

[20180004407/downloads/20180004407.pdf](https://ntrs.nasa.gov/api/citations/20180004407/downloads/20180004407.pdf). – Date of access: 14.07.2023.

16. *Study on Numerical Simulation Methods for Hypervelocity Impact on Large-Scale Complex Spacecraft Structures* / Y. Zhang [et al.] // *Aerospace. – 2022. – Vol. 9 (1), iss. 12. – P. 1–42.*

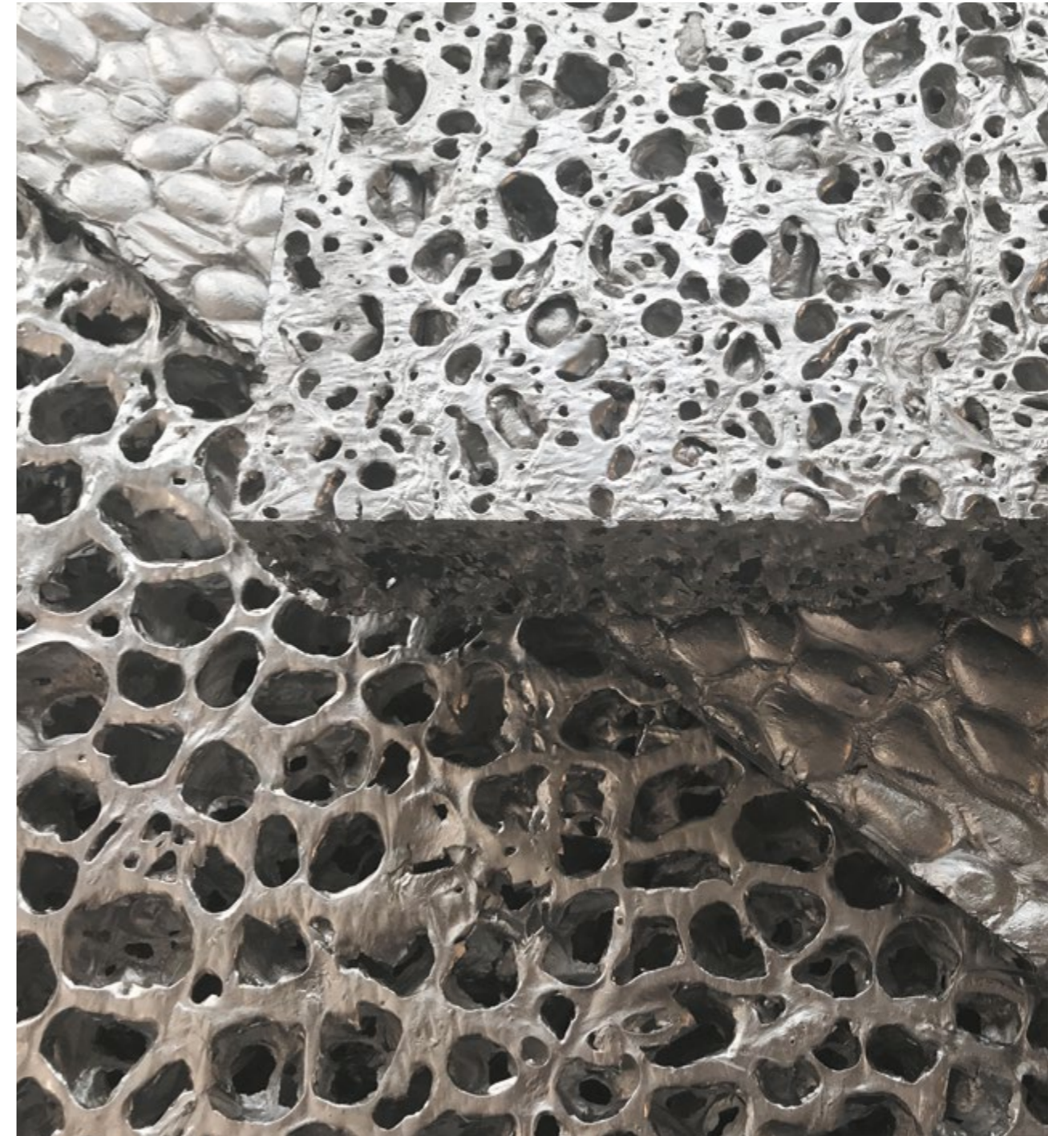

UDC 661.961

Use of Hydrogen-Containing Substances for Delivery of Building Materials to Near-Earth Orbit

A. Baravik¹
Ph.D. in Engineering Sciences

V. Garanin²
Ph.D. in Engineering Sciences

¹ Belarus State Economic University,
Minsk, Belarus

² Unitsky String Technologies Inc.,
Minsk, Belarus



H₂

”

There is an analysis of the possibilities of applying the most common hydrogen-containing substances for the delivery of basic building materials to space. Special attention is paid to the mechanism for obtaining energy from the raw materials being transported and intended for construction in near-Earth orbit. In particular, there is a study of the possibilities of using secondary substances of hydrogen production to build large objects in outer space. The energy component has not been assessed, that indicates the first phase of the proposed research in the logistics relevant to the delivery of building materials from Earth to orbit.

Keywords:

ammonia, carbon, construction, hydrogen, method of production, nitrogen, oxygen, space conditions, storage, transportation, water.

Introduction

The construction and operation of large objects in space, for example, the Industrial Space Necklace "Orbit" (ISN "Orbit") [1], will require the use of a huge amount of building materials in the future. Since it is currently not possible to assume that they will be mined on asteroids or other cosmic objects, such materials are mainly planned to be delivered from Earth. This will require significant resources and entail an additional burden on the environment due to the need to create part of the production facilities on our planet.

Obtaining the final materials in space for construction from the "semifinished products" available on Earth (natural gas and water are considered as such) will reduce the harmful effects on nature as well as the cost of erecting objects by using space production conditions (vacuum and solar energy). Moreover, work on creation space shipyards in near-Earth orbit [2] is already underway.

Features of Building Materials Delivery into Space from Earth

The main idea of the study is to substantiate the creation of conditions not only for the delivery of raw materials necessary for the construction of space objects but also for its application in the performance of delivery work. To achieve this goal, materials obtained with the release of energy that can be spent on their ascent into space are suited best. First of all, attention should be paid to such substances as carbon, which is widely used on Earth as the main element in building materials (nanotubes, steels, polymer-type materials) [3], and hydrogen serving as an energy source (hydrogen power engineering). The diagram of obtaining building materials in space is shown in Figure 1.

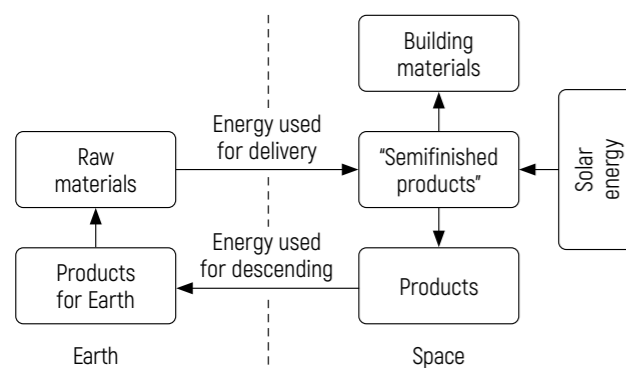
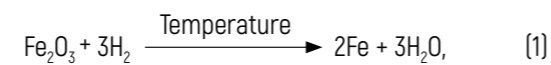

Figure 1 – Diagram of obtaining building materials in space

An assessment of the Earth and space capabilities shows that today our planet hosts large reserves of various metal oxides, methane (CH₄) and water (H₂O), which can be used as raw materials to produce, for example, steels, glass and carbon-based synthetic materials. In space, in turn, there are large reserves of solar energy and unique vacuum conditions that fits to create building materials directly on space objects.

Steels, consisting mainly of iron and carbon as well as a small number of alloying elements, are widely used in the construction. To deliver iron (Fe) into space, it is proposed to apply its oxides (Fe₂O₃) and to carry out the following chemical reactions in orbit or on Earth (requires additional economic study):



On their basis, it is possible to additionally obtain such a building material as alumina.

In order to determine the possibility of implementing the processes presented in Figure 1, the options for using the abovementioned raw materials in terms of chemical reactions were considered, and the number one issue discovered is the usage and storing hydrogen as a substance that is most involved in energy exchange during the delivery of building materials. To do this, it is necessary to evaluate the existing technologies for obtaining and transporting hydrogen on Earth in relation to its applying in orbit to meet the demand for materials and energy during the construction and operation of space objects.

Common Hydrogen-Containing Materials on Earth

The most common natural hydrogen-containing materials on Earth include water (H₂O) and natural gas (CH₄), where energy is stored in the form of chemical bonds with H₂. There is practically no free (molecular) hydrogen on our planet. A small amount of this gas is present in the upper layers of the atmosphere, where it is formed mainly by the decay of water vapor molecules due to them absorbing solar radiation. A large amount of hydrogen is found on Earth in a chemically bound form. Its main compound is the water of oceans, seas, lakes, glaciers, rivers, etc. In addition, elemental hydrogen is present in the form of ions in various acids

as well as in the form of atoms in organic compounds with covalent bonds (natural gas, oil, petroleum products, alcohols, esters, proteins, carbohydrates, fats, etc.).

Free hydrogen is used as an intermediate product:

- in the production of ammonia, nitric acid, nitrogen and complex fertilizers, explosives;
- in the processes of hydrocracking of petroleum products and hydrogenation (for example, unsaturated fats in the production of margarine);
- in various low-tonnage science-intensive industries, such as the electronic, electrical, glass, pharmaceutical and food ones;
- in biotechnologies;
- in the smelting of metals and alloys of high purity;
- in the synthesis of chemically highly active substances, etc.

However, molecular hydrogen is rarely used as an energy carrier for energy production (for example, as fuel in internal combustion engines (ICE) and hydrogen burners, in electrochemical fuel cells). The main reason for the limited application of primary hydrogen is that it is practically non-existing in the pure free state, therefore H₂ is obtained with the expenditure of energy or raw materials (or both).

In nature, molecular hydrogen is primarily as a part of natural gas (depending on the type of gas, the content of this substance varies from fractions of a percent to several percent) and, as a rule, is burned together with other gas components. At the same time, gas processing plants are being built and operated in many countries (for example, the Amur Gas Processing Plant in Russia), where natural gas is divided into components, including the production of molecular hydrogen.

Thus, free H₂ is widely used as a technological raw material in industry, but there are serious difficulties with its receipt, transportation and storage, which is the main factor limited application.

Currently the prospects for obtaining and using H₂ as a secondary energy carrier have been determined (for example, in hydrogen batteries with excess electrical energy as well as fuel in various ICEs that do not require massive and expensive fuel cells unlike electric batteries). However, it is not possible to switch to hydrogen energy completely due to the natural ways of energy storage on Earth, namely photosynthesis in green plants, where carbon and oxygen are involved:

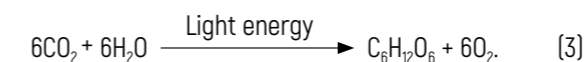

In addition, there are no serious grounds for the prevailing use of hydrogen as a final source of energy considering the prospects for the development of nuclear, solar, wind, hydraulic and thermal energy with access to electric energy at the end of the energy chain, which is considered more convenient and preferable on Earth [4]. This is primarily due to a significant decrease in the overall efficiency factor of energy chains with hydrogen compared to chains with other primary energy carriers.

The core process of obtaining energy (Q) when using H₂ as an energy carrier is described by a well-known generalized chemical reaction [5]:

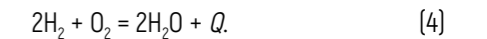

The main advantage of this process is its eco-friendliness, since the starting substances and reaction products are environmentally friendly if pure oxygen is used as an oxidizer (in reaction with air, a certain amount of very toxic nitrogen oxides (NO₂, NO) and other harmful substances are formed because of the presence of other gases, dust and organic compounds). In addition, hydrogen has a high calorific value per unit mass. Its specific heat of combustion is equal to 141 MJ/kg (in comparison, this indicator for methane is 50.2 MJ/kg, and it's even less for other fuels). For this reason, there are broad prospects for applying hydrogen as a secondary energy carrier accumulating a large amount of energy with a relatively insignificant mass involved.

For H₂ production it is especially rational to use superfluous energy that left after any process and cannot be simply and cheaply saved, which is proposed to be taken into account during the ascent of hydrogen-containing materials into near-Earth orbit. It is well known that the generated electric energy is mainly consumed immediately after its production at power plants, and the operation of a huge fleet of electric batteries storing excess energy (for example, generated at night at a nuclear power plant and not in demand by consumers) is economically costly and technologically complex. In space conditions, where volumes have less influence on the choice of the method of energy transportation and storage, hydrogen turns out to be a more promising substance compared to other gases (for example, methane).

Free H₂ is obtained in different ways, where oxygen and hydrogen play an important role [6].

1. Electrochemical decomposition of water with the help of electrical energy, which is possible with the use of catalysts.

With this method, an electrochemical reaction takes place, written by a generalized equation:

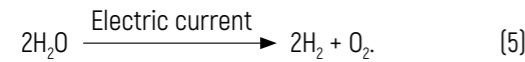

There are many variants of technical execution of such a technological process. In most cases we see the use of electrolyzers, i.e., pools with electrolytes (aqueous solutions of acids or alkalis), where the anode and cathode are being immersed under electric voltage. There are circuits with semidry electrolytes as well.

2. Thermal chemical reactions at high temperatures, often in the presence of special catalysts. Theoretically, the thermal decomposition of water is possible by the following reaction:

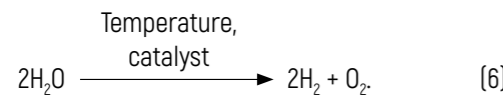

This process requires special catalysts and high temperatures, and its energy efficiency is quite low, therefore, in practice, such technology is rarely used on Earth.

3. Steam treatment of coal, implemented in special gas generators, where water vapor is passed over a white-hot layer of coke (coal heated without oxygen access). In this case, due to the high temperature, hydrogen atoms in water are replaced by carbon atoms under the following reaction:

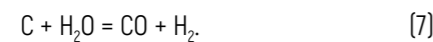

A mixture of carbon monoxide and hydrogen is separated and sometimes used as fuel without separation. It is not rational due to the release of carbon dioxide (CO₂) into the atmosphere, which can be excluded in space and used to produce carbon by implementing an endothermic reaction:

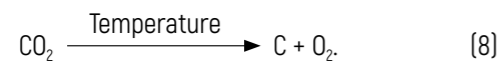

4. Steam conversion of methane [7]. This process takes place at a high temperature (about 1,000 °C). In this case, methane interacts with water vapor, carbon dioxide or a mixture of water vapor and carbon dioxide in the presence of a nickel-based

catalyst with additives of magnesium oxides, aluminum and other metals:

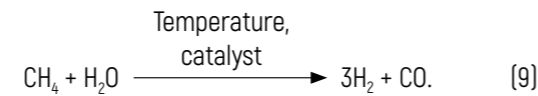

The main reforming reaction proceeds according to the diagram shown in Figure 2.

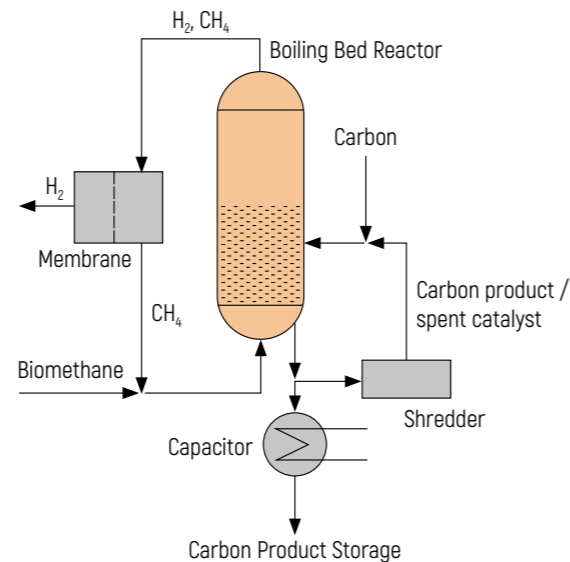
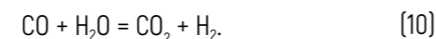

Figure 2 - Diagram of methane pyrolysis with a carbon catalyst

The resulting mixture of hydrogen and carbon monoxide must then be additionally treated with water vapor, which makes it possible to turn toxic carbon monoxide into relatively harmless carbon dioxide and increase the yield of hydrogen:



Stages and equipment of steam conversion:

- 1) hydrogenation of raw materials on a cobalt-molybdenum catalyst in a tubular apparatus and absorption of hydrogen sulfide;
- 2) preliminary reforming;
- 3) convection reforming in the pipes of the specially designed furnace filled with a nickel catalyst, which is deposited on an aluminum substrate. The heat required for the process

is supplied through the walls of pipes heated from the outside by burning another part of the natural gas;

4) conversion of the released CO into CO₂ in the tubular apparatus shown in Figure 2;

5) purification of product hydrogen in the block of short-cycle adsorption.

In terms of energy costs, steam treatment of coal and steam conversion of methane are the lowest cost technologies (much more efficient than the electrolysis of water and hydroelectrolytes). However, these processes leave a carbon footprint in the form of carbon dioxide, which it is advisable to capture and convert into a building material [8] [3].

There is a major drawback in this technology – it needs oxygen in chemical reactions. Herewith, there are already existing industrial methods when a reaction occurs under the influence of high temperatures and using an alloy of bismuth and nickel:

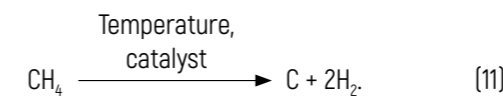

The yield of free molecular H₂ in such a scheme is almost half that of the steam conversion of methane. In this case, there is no greenhouse gas footprint in the form of gaseous CO₂, and solid carbon can be relatively easily separated from hydrogen and applied in other industries, for example, in the production of carbon fiber, graphene, carbon tubes, etc. Moreover, these materials are successfully used in the construction of various structures, including those built in space.

At the same time, these technologies require the energy needed to lift carbon into space, and here it is advantageous to consider the usual reaction of methane combustion with the formation of water and carbon dioxide (in space conditions it is better to divide it into carbon and oxygen):

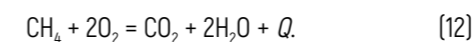

Thus, when free hydrogen is obtained, in addition to costs of energy which can be taken in space, substances are formed that participate in the synthesis of carbon-containing materials (carbon fiber, graphene, steel, etc.) for their subsequent use in space conditions.

Existing Hydrogen Transportation and Storage Technologies

The above chemical reactions occur with the formation of substances such as hydrogen, oxygen and carbon, which have their own characteristics of transportation and storage. It should be look hydrogen due to the special problems in this regard.

To date, molecular H₂ is accumulated, stored and transported in gaseous or liquid form. The density of liquid hydrogen (LH) is 70 kg/m³; the freezing point is 14.01 K (-259.14 °C); the boiling point is 20.28 K (-252.87 °C).

It is obvious that the density of LH is much higher than of the molecular one in the gaseous state (at a pressure of 1 atm and a temperature of 0 °C, it is 0.09 kg/m³). Therefore, LH is much preferable to the gaseous one of compact storage and use.

LH is a colorless, odorless liquid that becomes an explosive substance when mixed with air (its ignition coefficient is 4–75 %). LH needs cryogenic storage technology, including special heat-insulated containers and pipelines requiring special handling, which is typical for all cryogenic technologies. In this regard LH is close to liquid oxygen but assumes great caution because of the fire hazard. Even when containers with thermal insulation are applied, the substance is difficult to contain at a low temperature necessary for its preservation in a liquid state (it usually evaporates at a rate of up to 1% per day [7]). Under atmospheric pressure LH has a narrow temperature stability indicator – only 7 °C, which creates certain difficulties during its storage.

Despite all the disadvantages, LH is a common component of fuel used for the reactive acceleration of launch vehicles and spacecrafts. Due to the relatively low density and high specific heat of combustion, the mass of this substance in the rocket is relatively small, therefore, the mass of the payload transported into space is higher than in rockets running on other types of fuel.

In most liquid rocket engines, hydrogen is used for regenerative cooling of the nozzle and other parts of the engine before it is mixed with an oxidizer and burned to obtain thrust. LH can serve as a coolant (it is used as a refrigerant not only in rocket technology [8]). It is another advantage of it. Modern engines with H₂/O₂ components consume a hydrogen-enriched fuel mixture, which leads to a certain amount of unburned H₂ in the exhaust. In addition to increasing the specific impulse of the engine by reducing the molecular weight of the jet stream, the application of LH also reduces the erosion of the nozzle and combustion chamber.

However, in other areas, the need to create cryogenic storage conditions and the low density of LH are the factors that constrain its use. Only by 2009 it was possible to make an entirely hydrogen launch vehicle (Delta IV). To date, LH is used either on the upper stages of rockets or on boosters, which perform a significant part of the work on launching the payload into space while being in a vacuum. It indicates that application the substance in space is more advantageous compared to the Earth's atmosphere. As one of the measures to increase the density of this type of fuel, there are proposals to use sludge-like hydrogen, i.e., a semi-frozen form of liquid fuels.

An increase in density, and hence in compactness, can also be achieved by compressing and cooling molecular hydrogen gas. In addition, it does not require any cryogenic equipment and technology. Therefore, most of the Earth's ICEs and gas turbines operate on compressed hydrogen gas and its mixture with other combustible gases.

On Earth, salt caves are the most common method of storing hydrogen gas, as it is almost never polluted with impurities there and is never lost. There is research to develop a technology for storing H₂ using metal hydrides [9]. The second natural reservoir for hydrogen is depleted layers of natural gas or oil deposits and aquifers. They are bigger than salt caves, but the hydrogen in them gets dirty because it reacts with rocks, microorganisms and liquids.

Compressed hydrogen (at a pressure of 700 bar, i.e., approximately 690 atm) has only 15 % of the energy density (the amount of energy per unit volume) of gasoline, which means that storing an equivalent amount of fuel (for example, at a hydrogen gas station) requires seven times more area. For this reason, for transportation and storage hydrogen is mixed with ammonia (NH₃), which has a higher density. Such a mixture requires less space, which allows transporting a significant amount of the substance without increasing the storage volume. However, additional costs are needed for conversion and reconversion. In turn, ammonia can be produced using the following reaction:

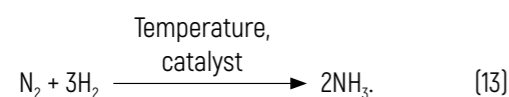

Thus, significant energy costs go to the liquefaction of hydrogen and the production of various mixtures. In the compression and cooling cycles, about 25–35 % of its mass is lost. The same operation on natural gas requires only 10 % of the mass. To partially solve this problem, hydrogen is mixed with other substances for transportation in liquid form.

The main contenders for the role of "fellow travelers" of H₂, as mentioned above, are ammonia and liquid organic hydrogen carriers (for example, methylcyclohexane (C₇H₁₄)). In order to mix hydrogen with ammonia it will be need 7–18 % of the energy from the supply volume. The same amount of H₂ is lost when it is released from this mixture. However, ammonia is liquefied at a temperature of –33 °C and contains 1.7 times more hydrogen per cubic meter, so it is cheaper to transport an ammonia-hydrogen mixture than pure H₂. This method of transportation is already widely used in practice [10]. Similarly, hydrogen can be incorporated into a liquid organic carrier. In this case, 35–40 % of H₂ is spent on conversion and reconversion. Some liquid organic hydrogen carriers may be incombustible, which makes transportation safer [11].

Due to the widespread use of pipeline transportation of natural gas, these highways are also promising for the movement of hydrogen [12]. However, not all of them are suitable for pumping it: pipes made of low-strength steel lose their usability because of the contact with H₂ (this process is called hydrogen embrittlement). When mixed with ammonia or natural gas, embrittlement is significantly reduced.

In some countries, H₂ is delivered by sea. So far, the production of tankers for the transportation of hydrogen is not introduced en masse. The first such vessel, named Suiso Frontier, was built by Kawasaki Heavy Industries and launched in December 2019 in Kobe (Japan) [13]. In March 2020, a reservoir with a volume of 1,250 m³, capable of transporting the substance in a liquefied state, was installed on the tanker.

Thus, the presented information indicates that it is rational to use free hydrogen immediately in the places of its production due to high transportation costs and storage difficulties on Earth. In space, these processes are easier to implement due to the presence of vacuum and ultralow temperatures (the designs of storage tanks for H₂ are simplified). It is complementing the conclusion that hydrogen as an energy source should be mainly used in space conditions. To improve the safety of transportation H₂ should be include in various mixtures with liquids that will be able to provide free hydrogen and various kinds of building materials after their processing.

Prospects for the Space Use of Hydrogen

Based on the presented data, a scheme for the transfer of basic substances to space for construction is proposed. The compiled diagram (Figure 3) shows the turnover of elements during the delivery of materials from Earth to orbit.

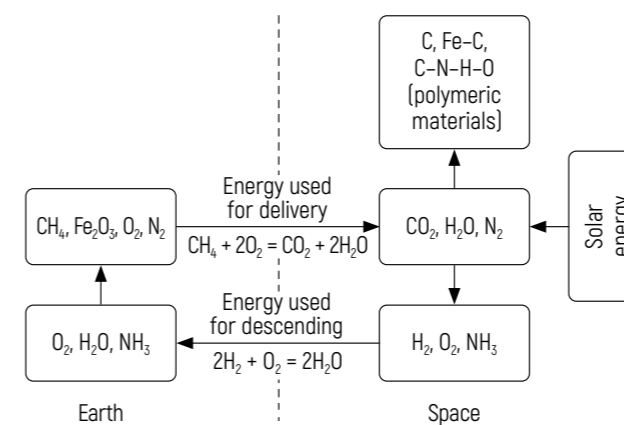

Figure 3 – Diagram of basic materials turnover

This figure does not reflect energy balances but demonstrates only the general mechanisms of the substances' turnover. Hydrogen, which is capable of accumulating a significant amount of energy per unit mass, should be primarily singled out among them.

When we talk about the construction of space objects, in addition to the use of raw materials located on Earth, attention should be paid to what is already available outside of it.

As is known, space has large reserves of hydrogen and hydrogen-containing substances (in the Solar System, for example, on Jupiter with its moons and Venus) [14]. It has been established that huge volumes of hydrogen, methane, ammonia and water are concentrated in the bowels of Jupiter and its atmosphere. There is a mass of water, sulfuric acid and ammonia in the Venus atmosphere. Space is full of moving comets and emissions of solar matter containing a lot of hydrogen. In these cases, all these objects should serve for extraction of substances.

Based on the above, the use of hydrogen is seen primarily as follows.

1. On the Moon you can build cities covered with hermetic domes. They will keep the atmosphere suitable for life. Substances under the dome will circulate in the regeneration mode. The primary energy for these cities will be solar panels grouped into special stations, which are described in [15]. The main energy will be electrical, while its excess will be used to produce H₂. Hydrogen will be a fuel for ICEs of vehicles traveling on the Moon away from charging power stations and conducting construction, extraction of fossil raw materials, etc.

This substance will be also used in other technologies described above. In the cold lunar atmosphere, it will be less

labor-intensive to energetically liquefy H₂. Hydrogen-containing and other raw materials can be transported from Earth, Jupiter, Venus, etc.

2. The use of LH involves the creation of special places on near-Earth orbital stations (for example, the ISN "Orbit") for its production, accumulation, storage and refueling of interplanetary spacecraft for manned and unmanned exploration of deeper space, primarily the Solar System depths. Even water can be carried as an effective load when transported from Earth to such a station (you do not need to waste energy to get H₂). There is an option of LH transportation using hydrogen-oxygen engines, where both fuel and cargo are the same, thus reducing the cost of transportation.

At the near-Earth station, numerous solar panels convert solar energy in the process of water electrochemical decomposition to produce hydrogen. The space cold will help to liquefy H₂ cheaply. Later volumetric tanks located in the shadow of solar panels (so that they are not heated) will be filled with this H₂. Interplanetary ships will approach the station, refuel with LH (the mass of the refueled ship is at least 95 % hydrogen; its engine, living and office premises, equipment, systems and life support materials, crew is no more than 5 %). The ship's engine is both nuclear and plasmic. A nuclear reactor emits a lot of energy, which is used to heat H₂ to many tens of thousands of degrees. Hydrogen is ionized to the plasma state; its ions are accelerated by the powerful electromagnetic fields of the engine superconductors, which are especially effective in cold space. The outflow rate of hydrogen ions from the nozzle of a plasma engine is an order of magnitude higher than the outflow rate of combustion products of conventional rocket jet engines. Therefore, the compact plasma engine creates tremendous thrust, making the interplanetary ship accelerating quickly and flying to the target at a speed of thousands of kilometers per second. In the result, the flight time is drastically reduced.

It should be noted that in the operation of space transport, we desire to avoid the use of jet propulsion, which leads to the loss of substances, including ionized hydrogen, as much as possible. The laws of conservation of momentum and energy allow us to look for ways to control vehicles in places of acceleration, deceleration and maneuvering. The application of the principle that the acceleration of one body leads to the deceleration of another contributes to the development of the concept of cost-free interaction of bodies in space. This principle, in particular, is implemented in the General Planetary Vehicle [16], which provides for lifting cargo into near-Earth orbit without the use of jet propulsion.

Conclusion

Pure hydrogen, due to problems with its transportation and storage as well as low specific gravity, is more promising for use in space than on Earth. The use of H₂ in the conditions of our planet can be considered as part of the main application in outer space.

If we look at accumulating energy obtained during various chemical processes, it is more efficient to use the substance that is available on Earth mainly in hydrogen-containing materials.

When pure H₂ is used as an energy carrier in order to increase the specific capacity (per unit volume) of stored energy, then its form should be liquid or slush.

It is easier to provide storage and transportation of LH in space, since it is less energy- and labor-intensive to maintain ultralow temperatures in vacuum conditions. To date, it is better to transport hydrogen to Earth together with other substances including it, for example, ammonia.

The production of H₂ from hydrogen-containing raw materials (natural gas, water) can serve as the basis for the delivery of materials that are in a bound form and are necessary for the construction of the ISN "Orbit".

It is proposed to use natural gas and metal oxides, which are available in large quantities on Earth, to transport steels, cast iron and various polymers into space.

For further industrial space exploration, the development of technologies for the use of secondary products formed during the release of molecular hydrogen seems promising. These substances are planned to be used for the production of materials that can be applied in the construction of various cosmic objects then, including the ISN "Orbit".

References

1. Unitsky, A. *String Transport Systems: On Earth and in Space* / A. Unitsky. – Silakrogs: PNB Print, 2019. – 560 p.
2. *Novyy etap v osvoyenii dal'nego kosmosa. Rossiya nachala stroit' orbital'nuyu kosmicheskuyu verf' [New Stage in the Exploration of Deep Space. Russia Has Begun to Build an Orbital Space Shipyard]* [Electronic resource]. – Mode of access: https://dzen.ru/a/YNneFDGagp1a2D-FZ?utm_referer=www.google.com. – Date of access: 12.07.2023.
3. Rudenkov, A.S. *Uglerodnyye nanotrubki: klassifikatsiya, osobennosti sinteza, metody issledovaniya, oblasti primeneniya [Carbon Nanotubes: Classification, Features of Synthesis, Research Methods and Applications]* / A.S. Rudenkov,

M.A. Yarmolenko // *Problemy fiziki, matematikii tekhniki*. – 2019. – No. 2 [39]. – P. 7–14.

4. Solodova, N.L. *Vodorod kak perspektivnyy energonositel'. Sovremennyye metody polucheniya vodoroda [Hydrogen as a Promising Energy Carrier. Modern Methods of Hydrogen Production]* / N.L. Solodova, R.R. Minigulov, Ye.A. Yemel'yanycheva // *Vestnik Kazanskogo tekhnologicheskogo universiteta*. – 2015. – No. 3. – P. 137–140.
5. Gelfand, B.Ye. *Vodorod: parametry goreniya i vzryva [Hydrogen: Parameters of Burning and Explosion]* / B.Ye. Gelfand, O.Ye. Popov, B.B. Chayvanov. – Moscow: Fizmatlit, 2008. – 288 p.
6. *Proizvodstvo vodoroda iz organicheskogo syr'ya [Production of Hydrogen from Organic Raw Materials]* / M.F. Krotov [et al.] // *Energiya: ekonomika, tekhnika, ekologiya*. – 2011. – No. 11. – P. 2–10.
7. *Khraneniye vodoroda [Hydrogen Storage]* [Electronic resource]. – Mode of access: http://newchemistry.ru/letter.php?n_id=1381. – Date of access: 12.07.2023.
8. Unitsky, A. *Justification for the Possibility of Hydrogen Use as a Refrigerant in Hypervelocity Vehicles* / A. Unitsky, V. Garanin, V. Yanchuk // *Non-Rocket Near Space Industrialization: Problems, Ideas, Projects: Collection of Articles of the V International Scientific and Technical Conference, Maryina Gorka, Sep. 23–24, 2022* / Astroengineering Technologies LLC, Unitsky String Technologies Inc.; ed. A. Unitsky. – Minsk: StroyMediaProject, 2023. – P. 64–73.
9. Tarasov, B.P. *Problema khraneniya vodoroda i perspektivy ispol'zovaniya gidridov dlya akkumulirovaniya vodoroda [Problem of Hydrogen Storage and Prospects for the Use of Hydrides for Hydrogen Storage]* / B.P. Tarasov, M.V. Lototskiy, V.A. Yartys' // *Zhurnal Rossiyskogo khimicheskogo obshchestva im. D.I. Mendeleyeva*. – 2006. – Vol. L, No. 6. – P. 34–48.
10. Alekseyeva, O.K. *Transportirovka vodoroda [Transportation of Hydrogen]* / O.K. Alekseyeva, S.I. Kozlov, V.N. Fateyev // *Transport na alternativnom toplive*. – 2011. – No. 3 [21]. – P. 18–24.
11. *Hydrogenious LOHC Technologies* [Electronic resource]. – Mode of access: https://www.youtube.com/channel/UCgUKTg8YF9m_NfqWL_TvLJA. – Date of access: 12.05.2023.
12. *Nadozhnost' i bezopasnost' magistral'nogo truboprovodnogo transporta [Reliability and Safety of Trunk Pipeline Transport]: Collection of Abstracts of the VIII International*

Scientific and Technical Conference, Novopolotsk, Nov. 25–28, 2014 / Polotsk State University; ed. V.K. Lipsky. – Novopolotsk: PGU, 2014. – 168 p.

13. *Kawasaki postroila pervyy v mire tanker dlya perevozki vodoroda [Kawasaki Has Built the World's First Hydrogen Tanker]* [Electronic resource]. – Mode of access: <https://neftegaz.ru/news/Suda-i-sudostroenie/681764-kawasaki-sozdala-pervyy-v-mire-tanker-dlya-perevozki-vodoroda/>. – Date of access: 12.05.2023.
14. Basilevsky, A.T. *The Surface of Venus* / A.T. Basilevsky, J.W. Head // *Reports on Progress in Physics*. – 2003. – Vol. 66, No. 10. – P. 1699–1734.

15. Kozhanova, E. *Space-Based Solar Power Plants as Elements of a Distributed Power System* / E. Kozhanova, Sh. Meignan // *Non-Rocket Near Space Industrialization: Problems, Ideas, Projects: Collection of Articles of the IV International Scientific and Technical Conference, Maryina Gorka, Sep. 18, 2021* / Astroengineering Technologies LLC, Unitsky String Technologies Inc.; ed. A. Unitsky. – Minsk: StroyMediaProject, 2022. – P. 231–245.
16. Unitsky, A.E. *Strunnyye transportnyye sistemy: na Zemle i v Kosmose [String Transport Systems: On Earth and in Space]* / A.E. Unitsky. – Minsk: Bielaruskaja navuka, 2017. – 342 p.: ill.



Possibility of Using Liquid Hydrogen Simultaneously as a Refrigerant and a Source of Energy for Cosmic Vehicles

A. Unitsky^{1,2}
Dr. of Philosophy
in Information Technologies
(Transport)

V. Garanin²
Ph.D. in Engineering Sciences

V. Yanchuk^{2,3}

¹ Astroengineering Technologies LLC,
Minsk, Belarus

² Unitsky String Technologies Inc.,
Minsk, Belarus

³ Belarusian National
Technical University,
Minsk, Belarus



The article presents calculated data on the possibility of using hydrogen as a refrigerant and energy source for cosmic vehicles operating on the lines of the Industrial Space Necklace "Orbit" (ISN "Orbit"). This gas has a high value of specific heat capacity and thermal conductivity and is also involved in the generation of electrical energy in hydrogen fuel cells. Currently, the main obstacles to the use of hydrogen are its unsafe operation as well as difficulties with transportation due to its low density. Free hydrogen (in the form of H_2) in the liquid phase partially solves these problems. In this connection, the article considers the use of cryogenic tanks that act simultaneously as tanks and evaporators, in which hydrogen is not only transported but is also vaporized due to the installation of an additional heat exchanger into the cryogenic tank. The authors emphasize the analysis of the generated cooling power of tanks for transportation of liquid hydrogen when refrigerants (helium, methane, propane, butane, etc.) are used in the secondary circuit.

Keywords:

circuit, Dewar vessel, heat capacity, hydrogen, Industrial Space Necklace "Orbit" (ISN "Orbit"), liquid, refrigerant, safety.

Introduction

The concept of a hypervelocity vehicle [1] provides for its operation in a forevacuum or at low pressure, where heat transfer is possible only by radiation. In vacuum, there are no medium resistance forces, which creates ideal parameters from the point of view of kinematics for the motion of transport – a vacuum vehicle (VV). However, in this case it has to operate completely autonomously, including in the field of energy exchange. Any thermal energy that cannot be used for its intended purpose in the VV must be diverted (under normal conditions it diffuses into the environment), which requires the introduction of special systems. When converting energy from one type to another, there are always losses in the form of heat (characterized by the conversion efficiency factor). Useful utilization of waste (excess) heat flows can be provided by means of appropriate devices – heat accumulators (utilizers). The lower is the total efficiency factor of energy conversion, the more excess heat has to be utilized and the greater is the load on heat utilization systems in the VV.

In this article, the load on the heat utilization system is estimated depending on the efficiency factor of conversion of chemical energy of gases into electrical energy in fuel cells (FC). The research method is based on the calculation of balance equations for the VV cooling system.

Utilization of Thermal Energy in Space

Functioning of the General Planetary Vehicle (GPV) will take place partially in space, i.e., in vacuum conditions [2], which will cause problems with energy conversion required for acceleration and deceleration of the belt flywheels, the total mass of which can reach 38 mln tons [3].

Having taken into account that the efficiency factor of all transformations in the system of linear electric motors at the stages of the GPV ascent and descent can be $\eta = 0.973$ [3], the amount of heat released during the acceleration/deceleration of the flywheels, based on the law of energy conservation, can reach the equivalent of more than 100 mln kW·h of energy. It is reasonable to accumulate all the thermal energy obtained for further consumption, thus not affecting the Earth's atmosphere. Hence, the use of cryogenic hydrogen may be relevant in this case.

The study of the issue of utilization of heat exchange in outer space only by means of radiant heat exchange has shown that due to the variable operating conditions of space

objects it is impossible to completely solve the problem of providing the thermal mode only by applying coatings with certain radiation characteristics [4]. The automation system installed on board the VV, which, if necessary, should utilize the excess heat using only internal resources, will make it possible to cope with this task.

In confirmation of the above, in a spacecraft with heat-producing equipment located in unsealed compartments, liquid heat carriers circulating in the pipelines of liquid circuits are used to transfer a large amount of heat to an isolated radiation surface or to remove (supply) heat from high-power sources with high specific heat release density [4]. If the temperature of the circulating heat carrier is maintained within the specified limits, it, in addition to heat transfer, will also stabilize the temperature of the elements that have a direct thermal contact with it. Thus, devices that need cooling are installed on temperature controlled boards through which the heat carrier is circulated. In some cases, it is fed directly into the devices to cool heat-stressed elements. Hydrocarbons, organosilicon liquids, freons, aqueous solutions of ethylene glycol, water and others are used as heat carriers.

As a rule, thermal management equipment (TME) is a set of various devices that regulate external and internal heat exchange of a spacecraft. Typically, TME systems include:

- complex of means of active regulation of thermal processes, called a thermal management system (TMS);
- passive thermal control devices (PTCD).

TMS includes ventilation equipment, a liquid circuit with heat exchange devices and means of heat flow control, active means of regulating radiant heat exchange, etc. PTCD are structural elements that ensure specified parameters of heat exchange with radiation and heat conductivity (thermal control coatings, various kinds of thermal insulation and heat protection, thermal bridges and thermal resistances).

In addition, there are technologies to divert heat in space using hyperthermal conductive panels whose operation is similar to heat pipes (Figure 1) [5].

The presented idea is based on the use of phase transition features of special liquids on the solar and shadow sides of spacecraft. Due to capillary forces of the fuse, the liquid constantly returns to the place of heat input.

The application of thermal batteries for diversion of short-term heat flows of increased power (SHFIP) is considered in [6] (Figure 2).

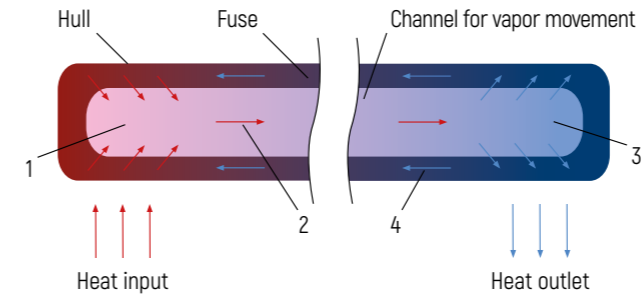

Figure 1 – Diagram of operation of hyperthermal conductive panels.

Stages of the thermal cycle:

- 1 – liquid evaporation and heat absorption;
- 2 – vapor movement to the cold section;
- 3 – vapor condensation and heat release;
- 4 – liquid movement to the hot section

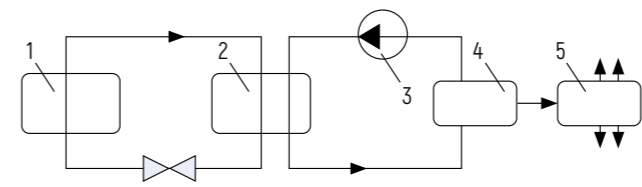

Figure 2 – Circuit diagram of the use of thermal batteries:

- 1 – source of SHFIP; 2 – heat exchanger;
- 3 – pump; 4 – reservoir with working body;
- 5 – evaporative emitter

Substances that can be involved in heat utilization systems with the use of working body discharge are presented in [6]. Water is the most preferred liquid. Four groups of substances are also proposed to be applied as heat storage material: paraffins, fatty acids, salt hydrates and a number of metal compounds.

This article focuses primarily not only on heat utilization systems but also on systems that function simultaneously as waste heat exchangers and energy sources, which will be additionally emphasized later.

In [7] indicates the possibility of using hydrogen in unpiloted aerial vehicles (UAVs). In particular, the electric power plant for UAV motors includes a FC and a high-pressure hydrogen battery. The hydrogen battery is in the form of multicapillary objects located inside hollow structural elements of the UAV. In this case, hydrogen acts as a fuel and also as a lifting gas in the hull structure.

The amount of energy to be accumulated in the enclosed space depending on the FC efficiency factor is presented in a mathematical substantiation. The abovementioned review of some literature sources has shown that it is more

convenient to utilize the excess heat, which is received by the VV from external or internal energy sources, with the help of special liquid or gaseous heat storage materials [8].

Mathematical Substantiation of Using Hydrogen for Heat Utilization in Space

Here are mathematical calculations showing the possibility of using hydrogen (as the cleanest energy source in space) as an energy source and heat storage material.

Based on [9], the chemical reaction of oxygen and hydrogen (in moles) occurs with the release of heat:

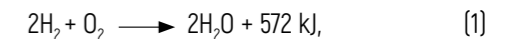

i.e., when 4 g of hydrogen interacts with 32 g of oxygen, 36 g of water is formed and 572 kJ of energy is released.

Taking into account the FC efficiency factor, the hydrogen consumption G_{H_2} (kg/s) required to obtain the power P (kW) of electrical energy will be expressed by the following dependency:

$$G_{\text{H}_2} = \frac{0.004P}{572\eta}. \quad (2)$$

Therefore, the oxygen consumption G_{O_2} (kg/s) and the water formation rate $G_{\text{H}_2\text{O}}$ (kg/s) will be expressed by the following dependencies:

$$G_{\text{O}_2} = \frac{0.032P}{572\eta}, \quad (3)$$

$$G_{\text{H}_2\text{O}} = \frac{0.036P}{572\eta}. \quad (4)$$

According to [10], the most widespread FCs have an efficiency factor of about 40 %, which, based on the above calculations, makes it possible to determine the amount of substances involved in the process of generating electrical energy.

A vehicle with a travel time of 0.5 h between the final destinations, carrying six passengers, and the mechanical power of the electric motor P_{mech} is equal to 100 kW with a mechanical efficiency factor of 90 % ($\eta_{\text{mech}} = 0.9$) has been considered as an example. Electrical energy is supplied to the electric motor from the converter, which is, in particular, a hydrogen FC, having an electrical efficiency factor of 40 % ($\eta_{\text{FC}} = 0.4$). The power of heat emission of one passenger at rest P_r is 0.1 kW. The power of heat emission of onboard equipment without taking into account the motor is taken as 1 %

of the electric power of FC, i.e., $P_{x1} = 0,01P/\eta_{mech}$. This diagram is described in [11] and presented in Figure 3.

For the generated FC power of 111 kW at $\eta_{FC} = 0,4$ the consumption of hydrogen and oxygen per second and the amount of water obtained will be: $G_{H_2} = 1,94$ g/s; $G_{O_2} = 15,54$ g/s; $G_{H_2O} = 17,48$ g/s.

As the FC efficiency factor increases, these values will decrease (Figure 4).

According to [11], the diagram of the heat utilizer with the use of cryogenic liquids is shown in Figure 5. The process of liquid hydrogen boiling is proposed to be carried out directly in Dewar vessels, which are applied for its transportation. The enclosed secondary circuit with a refrigerant having the temperature of transition to the solid phase below the boiling point of liquid hydrogen (helium can be used as such a refrigerant, which does not transition to the solid phase at the temperatures of liquid hydrogen), provides flow circulation and heat supply for boiling directly into the Dewar vessel. As the liquid hydrogen boils, its level decreases and the working part of the liquid immersion circuit decreases.

Secondary circuits with flows of heated air or other refrigerants from the vehicle interior, motors and other elements that need to be cooled can be connected to this circuit for heat exchange. The use of secondary circuits will make it possible to effectively prepare the refrigerants circulating in them (for example, to separate the water contained in the cooled air, which can clog the secondary circuit when it freezes).

The gaseous hydrogen obtained as a result of boiling in the Dewar vessel enters the supply system of the hydrogen FC. This system can be supplied with gaseous hydrogen from a separate tank or from the main line in which the VV moves.

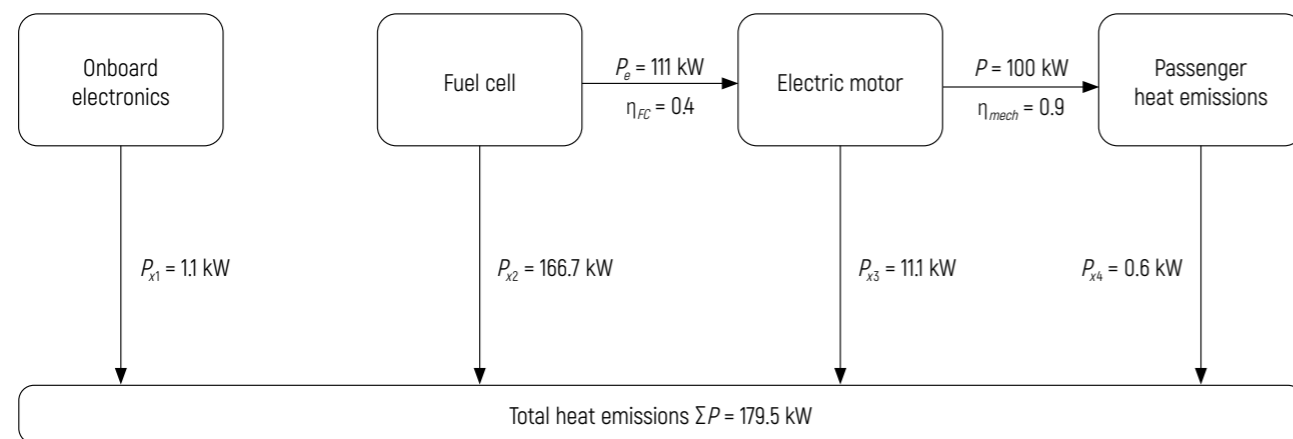

Figure 3 - Structure of thermal power formation

This solution contributes to power generation irrespective of the presence of gaseous hydrogen in the environment where the VV is operating.

The following parameters of refrigerants are set (Figure 6): at the inlet to the FC the temperature of hydrogen and oxygen for the reaction t_r is equal to 20 °C; the temperature of liquid hydrogen and oxygen in cryogenic tanks will be respectively: $t_{H_2} = -253$ °C; $t_{O_2} = -183$ °C.

Based on Figure 3, the total heat output to be utilized is determined by the following dependency:

$$\Sigma P = NP_r + P \left(\frac{1}{\eta_{mech} \eta_{FC}} - 1 + \frac{0,01}{\eta_{mech}} \right). \quad (5)$$

Since for generation of 1 kW·h of electric power according to (2) an ideal FC needs hydrogen with mass m , equal to 25.17 g, the consumption of hydrogen G_{H_2} (kg/s) and oxygen G_{O_2} (kg/s) for creation of electric power P (kW) will be determined by the following dependencies:

$$G_{H_2} = \frac{mP}{3,600 \eta_{FC} \eta_{mech}}, \quad (6)$$

$$G_{O_2} = 8G_{H_2}. \quad (7)$$

The volume of liquid hydrogen V_{H_2} (m³) required for the VV operation during the time τ (h) will be expressed by the following regularity:

$$V_{H_2} = \frac{3,600G_{H_2}\tau}{\rho_{H_2}}, \quad (8)$$

where ρ_{H_2} – density of liquid hydrogen, kg/m³ ($\rho_{H_2} = 71$ kg/m³).

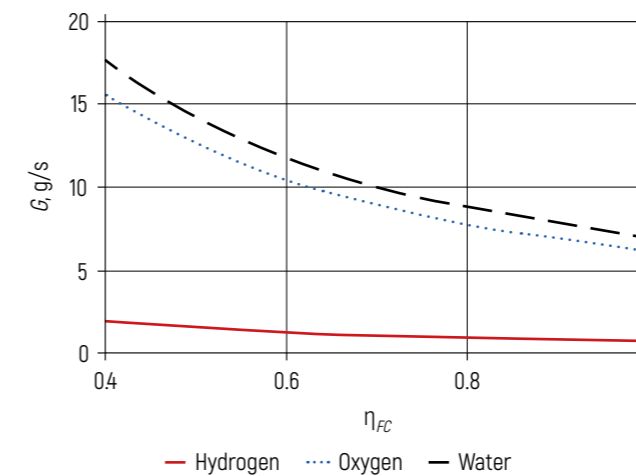

Figure 4 - Consumption of substances depending on the FC efficiency factor

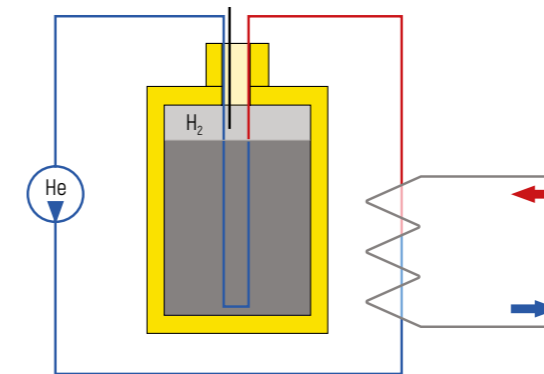

Figure 5 - Diagram of the heat utilizer with the use of liquid gas

The required volume of liquid oxygen V_{O_2} (m³) will be expressed by the following dependency:

$$V_{O_2} = \frac{3,600G_{O_2}\tau}{\rho_{O_2}}, \quad (9)$$

where ρ_{O_2} – density of liquid oxygen, kg/m³ ($\rho_{O_2} = 1,140$ kg/m³).

The thermal power required to vaporize the specified consumption of hydrogen and oxygen will be P_1 and P_3 (kW) respectively:

$$P_1 = \frac{G_{H_2} r_{H_2}}{1,000}, \quad (10)$$

$$P_3 = \frac{G_{O_2} r_{O_2}}{1,000}, \quad (11)$$

where r_{H_2} – heat of hydrogen vaporization, J/kg ($r_{H_2} = 460,500$ J/kg); r_{O_2} – heat of oxygen vaporization, J/kg ($r_{O_2} = 214,000$ J/kg).

The heat power required to heat hydrogen and oxygen to their reaction temperature t_r , will be P_2 and P_4 (kW) respectively:

$$P_2 = G_{H_2} (i_{r(H_2)} - i_{-253(H_2)}), \quad (12)$$

$$P_4 = G_{O_2} (i_{r(O_2)} - i_{-183(O_2)}), \quad (13)$$

where $i_{r(H_2)}$ – specific mass enthalpy of hydrogen at t_r , J/kg ($i_{r(H_2)} = 3,899,700$ J/kg);

$i_{r(O_2)}$ – specific mass enthalpy of oxygen at t_r , J/kg ($i_{r(O_2)} = 400,000$ J/kg).

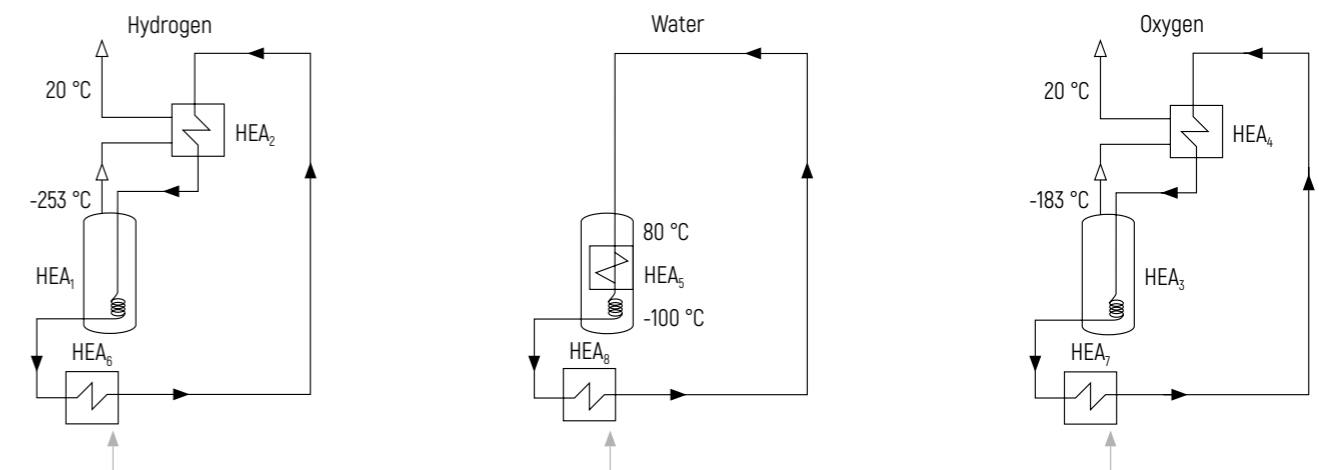

Figure 6 - Temperature of refrigerants in the circuits: HEA₁–HEA₆ – heat-exchange apparatus cooling the secondary circuit; HEA₇–HEA₁₂ – heat-exchange apparatus heating the secondary circuit

Substituting the values into dependences (4)–(13), it can be noted that the spent volume of liquid hydrogen and oxygen will be insufficient to utilize the heat generated during the VV operation (Figure 1). Taking into account the FC efficiency factor (40–100 %), it is possible to utilize only 7.7–43 % of the total heat with the help of liquid hydrogen and oxygen, which is primarily due to high energy losses during transformations in the electric part of the rolling stock. Consequently, further work in the direction of using hydrogen in the VV is inextricably linked with increasing of the FC efficiency factor as well as with reducing losses on the conversion of energy spent on motion.

Thermal Balance of Fuel Cell Operation

Other substances can be used to utilize the excess thermal energy, since the hydrogen and oxygen applied for the VV motion, as calculations show, are insufficient. According to [5], supercooled ice is used as an additional heat storage material, which can be formed in cosmic conditions from water using, for example, hyperthermal conductive panels.

The temperature to which water must be heated is 80 °C, and the temperature of supercooled ice is -100 °C (Figure 7).

Based on the thermal balance (released, consumed and extra thermal energy), the ice consumption required to accumulate the extra thermal energy G_i (kg/s), taking into account a 15 % reserve, will be as follows:

$$G_i = \frac{1,150(\Sigma P - P_1 - P_2 - P_3 - P_4)}{c_i(0 - t_i) + j_i + c_w t_{H_2O}}, \quad (14)$$

where c_i – heat capacity of ice, J/(kg·°C) [$c_i = 2,100$ J/(kg·°C)];
 j_i – heat of ice melting, J/kg [$j_i = 333,500$ J/kg];
 c_w – heat capacity of water, J/(kg·°C) [$c_w = 4,200$ J/(kg·°C)].

Based on the abovementioned dependencies, the diagram of the thermal balance of the hydrogen motor is presented (Figure 7).

The analysis of dependencies shows that the considered system at 100 % FC efficiency factor forms 7.2 kW of excess energy power, which is produced mainly due to mechanical losses, as about 10 % of electric motors power goes into heat. The calculations are presented in the Table.

The mechanical efficiency factor of the motor at $\eta_{mech} = 0.97$ allows to refuse the use of an additional heat accumulator (ice) when using an ideal FC ($\eta_{FC} = 1$).

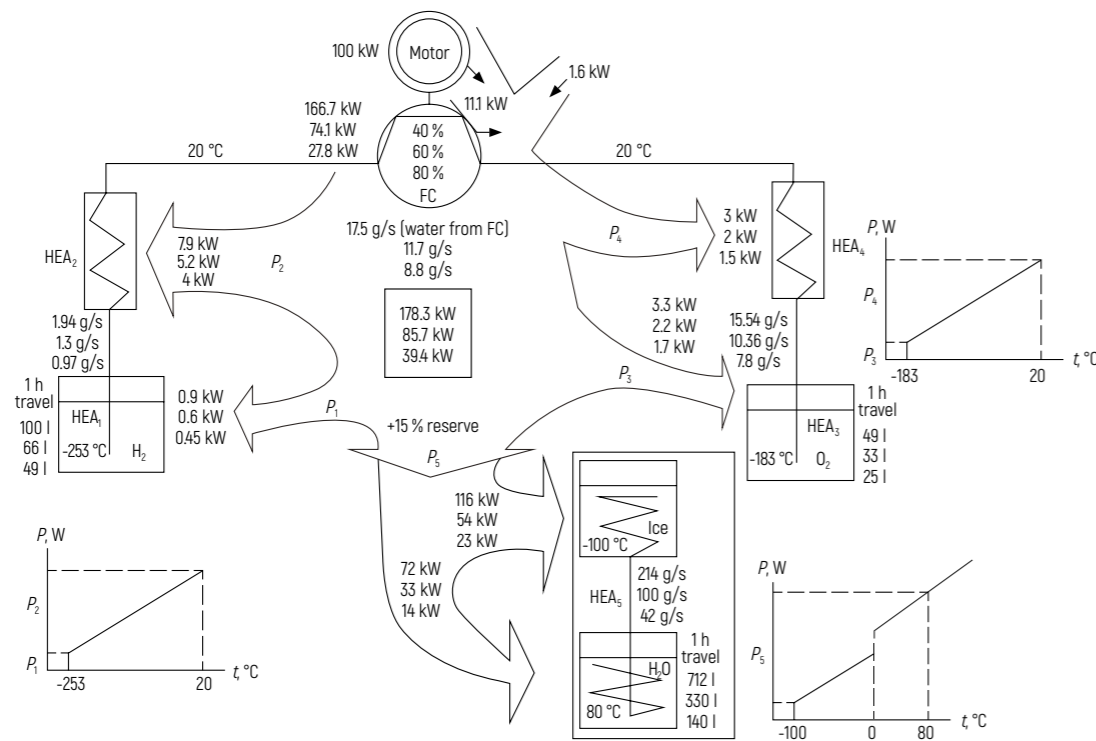

Figure 7 – Diagram of the thermal balance of the hydrogen motor heat utilizer depending on the FC efficiency factor

Table – Calculation of refrigerants power

Index	FC efficiency factor (η)						
	0.4	0.5	0.6	0.7	0.8	0.9	1
Electric motor power, kW	100						
Mechanical efficiency factor of electric motor	0.9						
Hydrogen consumption for FC at 100 % efficiency factor, g/kW·h	25.17						
Actual hydrogen consumption for FC, g/kW·h	62.925	50.34	41.95	35.95714	31.4625	27.96667	25.17
Hydrogen consumption for FC (by chemical reaction), g/s	1.94	1.55	1.29	1.11	0.97	0.86	0.78
Number of passengers, person	6						
Power of onboard electronics, kW	1.111111						
Thermal energy to be utilized, kW	179.4889	123.9333	86.8963	60.44127	40.6	25.1679	12.82222
Thermal energy absorbed during hydrogen evaporation, kJ/kg	461						
Thermal energy absorbed when hydrogen is heated in the range of 20–293 K, kJ/kg	3,438.7						
Total thermal energy absorbed by hydrogen, kJ/kg	3,899.7						
Refrigerating power of hydrogen heat exchangers, kW	7.6	6.1	5	4.3	3.8	3.4	3
Oxygen consumption for FC (by chemical reaction), g/s	15.53704	12.42963	10.35802	8.878307	7.768519	6.90535	6.214815
Volume of thermal energy absorbed during evaporation and heating of oxygen, kJ/kg	400						
Refrigerating power of oxygen heat exchangers, kW	6.2	5	4.1	3.6	3.1	2.8	2.5
Refrigerating power of the ice accumulator, kW	165.7	112.9	77.7	52.6	33.7	19	7.3
Final temperature of water formed from melted ice, °C	80						
Volume of thermal energy absorbed during heating and melting of ice from -100 °C to 0 °C, kJ/kg	479						
Heat capacity of ice, kJ/(kg·K)	4.2						
Volume of thermal energy absorbed during heating and melting of ice, heating of water, kJ/kg	815						
Weight of ice required for the ice accumulator, kg/s (g/s)	0.203 (203)	0.139 (139)	0.095 (95)	0.064 (64)	0.041 (41)	0.023 (23)	0.009 (9)
Water release, g/s	17.47917	13.98333	11.65278	9.988095	8.739583	7.768519	6.991667
Oxygen release, g/s	15.53704	12.42963	10.35802	8.878307	7.768519	6.90535	6.214815

Determination of Operation Parameters of Hydrogen Heat Utilizer

The case when only liquid hydrogen will act as a utilizer of excess energy is considered. Let us determine its quantity required for the abovementioned conditions. The diagram of the heat exchanger is shown in Figure 8.

In the proposed heat utilization option, the extra energy is used to heat liquid hydrogen before feeding into the hydrogen FC from a temperature $t_{H_1} = -253$ °C, at which the evaporator tank HEA₁ with liquid hydrogen is installed on the vehicle, to a temperature $t_{H_2} = 20$ °C, at which gaseous hydrogen is fed into the hydrogen FC.

A Dewar vessel of size SK-40 and nominal volume $V_D = 40$ l is taken as the evaporator tank HEA₂ and the following parameters of the heater of the coil heat exchanger placed in the evaporator tank are set:

- diameter of tube turn in the coil heat exchanger, mm ($d_{turn} = 60$ mm);
- number of turns ($n = 20$);
- turn pitch, mm ($a = 8$ mm);
- external diameter of the heat exchanger tube, mm ($d_2 = 4$ mm).

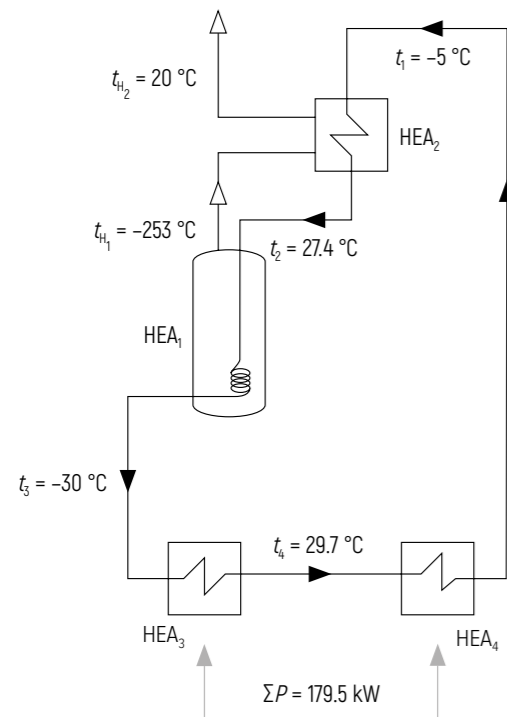

Figure 8 – Diagram of hydrogen heat utilizer

The total power of heat utilized in HEA₃ and HEA₄ ΣP is equal to 179.5 kW (the sum of $P_3 = P_{x1} + P_{x4} = 1.7$ kW – thermal power released by passengers and electronic equipment; $P_4 = P_{x2} + P_{x3} = 177.8$ kW – thermal power released by power electrical equipment).

Based on the conditions of providing the liquid phase of the refrigerant, we assume the following refrigerant temperatures in the secondary circuit:

- between heat exchangers HEA₂ and HEA₄: $t_1 = -5$ °C;
- between the evaporator tank HEA₁ and heat exchanger HEA₃: $t_3 = -30$ °C.

The temperature t_2 between the evaporator tank HEA₁ and the heat exchanger HEA₂ is determined from the ratio of thermal power:

$$t_2 = \frac{i_{r(H_2)} t_3 + r_{H_2} t_1}{i_{r(H_2)} + r_{H_2}}, \quad (15)$$

$$t_2 = \frac{3,899,700 \times (-30) + 460,500 \times (-5)}{3,899,700 + 460,500} = -27.4 \text{ °C.}$$

The temperature t_4 between heat exchangers HEA₃ and HEA₄ is determined from the ratio of thermal power:

$$t_4 = \frac{P_3 t_1 + P_4 t_3}{P_3 + P_4}, \quad (16)$$

$$t_4 = \frac{1.7 \times (-5) + 177.8 \times (-30)}{1.7 + 177.8} = -29.8 \text{ °C.}$$

The mass consumption of the secondary circuit refrigerant G_{ref} (kg/s):

$$G_{ref} = \frac{\Sigma P}{c_{ref}(t_1 - t_3)}, \quad (17)$$

where c_{ref} – refrigerant heat capacity, J/(kg·°C).

A similar equation for the mass consumption of hydrogen G_{H_2} (kg/s) taking into account (17) will have the following look:

$$G_{H_2} = \frac{G_{ref} c_{ref}(t_2 - t_3)}{r_{H_2}} = \frac{\Sigma P(t_2 - t_3)}{r_{H_2}(t_1 - t_3)}, \quad (18)$$

$$G_{H_2} = \frac{179,500 \times (-27.4 - (-30))}{460,500 \times (-5 - (-30))} = 0.041 \text{ kg/s} = 41 \text{ g/s.}$$

On the basis of dependences (10) and (12) the power consumption for boiling and heating of hydrogen will be: $P_1 = 21.2$ kW; $P_2 = 158.3$ kW.

On this basis, the heat exchange area f (m²) is determined:

$$f = \sqrt{a^2 + \pi^2 d_{turn}^2} \times n \pi d_2, \quad (19)$$

$$f = \sqrt{0.008^2 + \pi^2 0.06^2} \times 20 \pi \times 0.004 = 0.047 \text{ m}^2.$$

The heat transfer coefficient K taking into account the provision of turbulent forced motion of the refrigerant (helium) in the liquid phase in the secondary circuit (liquid flow velocity of 2 m/s at the 3 mm inner diameter of the tubes) can be taken equal to 400 W/(m²·K) [according to recommendations [12]].

The thermal power of one evaporator tank (Dewar vessel) P_D (kW) in this case will be as follows:

$$P_D = 0.001 K f \frac{(t_2 - t_{H_2}) - (t_3 - t_{H_2})}{\ln \left(\frac{t_2 - t_{H_2}}{t_3 - t_{H_2}} \right)}, \quad (20)$$

$$P_D = 0.001 \times 400 \times 0.047 \frac{(-27.4 - (-252.9)) - (-30 - (-252.9))}{\ln \left(\frac{-27.4 - (-252.9)}{-30 - (-252.9)} \right)} = 4.21 \text{ kW.}$$

According to the diagram shown in Figure 8, the refrigerant of the secondary circuit should have a liquid aggregate state in all four points, i.e., it is possible to use liquids having a temperature range of $-5... -30$ °C.

Based on the thermal balance, to utilize the thermal energy with a power of 179.5 kW $P_1/P_D = 21.2/4.21$, i.e., five Dewar vessels with a total production of m_{H_2} (kg) of hydrogen over a transport travel time of 0.5 h would be required:

$$m_{H_2} = 3,600 G_{H_2} \tau, \quad (21)$$

$$m_{H_2} = 3,600 \times 0.041 \times 0.5 = 73.8 \text{ kg.}$$

Conclusion

The presented calculations allow to conclude that, depending on the FC efficiency factor, it is possible to accumulate (utilize) by means of liquid hydrogen and oxygen not more than 43 % of the total thermal energy due to high conversion losses in electric parts of transport. By increasing the FC efficiency factor as well as reducing other conversion losses of energy (e.g., energy used for transport motion), the energy utilization efficiency index will improve – it will approach 100 %.

The analysis of dependencies demonstrates that at 100 % FC efficiency factor the considered transport generates 7.2 kW of discharge heat power, which is generated mainly due to mechanical losses (10 % of power is transferred into thermal energy during transformations). Only at 97 % efficiency factor of the mechanical part of the motor we can talk about a complete refusal from the use of an additional cold accumulator (at 100 % FC efficiency factor).

In addition, it can be asserted that the increase of hydrogen heat utilizer power is more influenced by the heat exchange area (which is limited by the dimensions of cryogenic vessels) than by the change in the characteristics of the liquid refrigerant of the secondary circuit. For this reason, the design of vessels, in which it is supposed to both transport liquid hydrogen and provide heat exchange, should be done taking into account the need to maximize the area of heat exchange elements (for example, installing heat exchangers on the walls and bottom of the vessels used).

Thus, the results of research show the possibility of using hydrogen as an energy carrier and refrigerant simultaneously, while the choice of parameters of the heat storage system should be carried out depending on the operating modes of the orbital transport, providing a full-fledged functioning in vacuum conditions of the ISN "Orbit", which will become in the future one of the grandiose artificial constructs of humankind in near-Earth space.

References

1. *Unitsky, A. String Transport Systems: On Earth and in Space / A. Unitsky. – Silakrogs: PNB Print, 2019. – 560 p.*
2. *Unitsky, A.E. Ispol'zovaniye vodoroda v kosmose: proshloye, nastoyashcheye, budushcheye [Use of Hydrogen in Outer Space: Past, Present and Future] / A.E. Unitsky, V.V. Vasilevich, V.L. Looksha // Bezraketnaya industrializatsiya blizhnego kosmosa: problemy, idei, proyekty: Collection of Articles of the III International Scientific and Technical Conference, Maryina Gorka, Sep. 12, 2020 / Astroengineering Technologies LLC, Unitsky String Technologies Inc.; ed. A.E. Unitsky. – Minsk: StroyMediaProyekt, 2021. – P. 206–219.*
3. *Unitsky, A. Creating a Mathematical Model of the General Planetary Vehicle Accelerating Flywheels, Passing the Atmosphere, Going into Orbit / A. Unitsky, R. Sharshov, A. Abakumov // Non-Rocket Space Industrialization: Problems, Ideas, Projects: Collection of Articles of the II International Scientific and Technical Conference,*

Maryina Gorka, Jun. 21, 2019 / Astroengineering Technologies LLC; ed. A. Unitsky. – Minsk: Paradox, 2019. – P. 77–83.

4. Tsaplin, S.V. *Teploobmen v kosmose [Heat Transfer in Space]: Study Guide* / S.V. Tsaplin, S.A. Bolychev, A.Ye. Romanov. – Samara: Izdatel'stvo Samarskogo universiteta, 2018. – 92 p.
5. *Kogda v kosmose zharko [When It Is Hot in Space] [Electronic resource]*. – Mode of access: <https://scfh.ru/papers/kogda-v-kosmose-zharko/>. – Date of access: 30.04.2023.
6. Kukhtin, A.V. *Prakticheskiye rekomendatsii po razrabotke sistemy obespecheniya teplovogo rezhima kosmicheskogo apparata [Practical Recommendations of the Spacecraft Thermal Control System Development]* / A.V. Kukhtin, A.M. Denisov, T.Yu. Devyatkina // *Izvestiya TulGU. Tekhnicheskiye nauki*. – 2018. – Iss. 11. – P. 113–123.
7. Denisov, Ye.I. *Akkumulyator vodoroda na osnove kapillyarnykh i mul'tikapillyarnykh struktur dlya energeticheskoy ustanovki bespilotnykh letatel'nykh apparatov [Hydrogen Accumulator on the Basis of Capillary and Multicapillary Structures for a Power Plant of Unpiloted Aerial Vehicles]: Patent RU 185 789 U1 / Ye.I. Denisov*. – Published 19.12.2018.
8. Raab, G. *Sistema utilizatsii otkhodyashchego tepla dvigatelya vnutrennego sgoraniya s ustroystvom zashchity ot zamerzaniya [A System for Utilization of Waste Heat from an Internal Combustion Engine with a Freeze Protection Device]: Patent RU 2 469 204 C2 / G. Raab*. – Published 10.12.2012.
9. Gelfand, B.Ye. *Vodorod: parametry goreniya i vzryva [Hydrogen: Combustion and Explosion Parameters]* / B.Ye. Gelfand, O.Ye. Popov, B.B. Chayvanov. – Moscow: Fizmatlit, 2008. – 284 p.
10. *Fuel Cell Membranes – Pros and Cons* / E. Ogungbemi [et al.] // *Energy*. – 2019. – No. 172. – P. 155–172.
11. Unitsky, A. *Justification for the Possibility of Hydrogen Use as a Refrigerant in Hypervelocity Vehicles* / A. Unitsky, V. Garanin, V. Yanchuk // *Non-Rocket Near Space Industrialization: Problems, Ideas, Projects: Collection of Articles of the V International Scientific and Technical Conference, Maryina Gorka, Sep. 23–24, 2022* / Astroengineering Technologies LLC, Unitsky String Technologies Inc.; ed. A. Unitsky. – Minsk: StroyMediaProject, 2023. – P. 64–73.
12. *Osnovnyye protsessy i apparaty khimicheskoy tekhnologii [Basic Processes and Apparatuses of Chemical Technology]: Design Guide* / ed. Yu.I. Dytnevskiy. – Moscow: Khimiya, 1983. – 272 p.

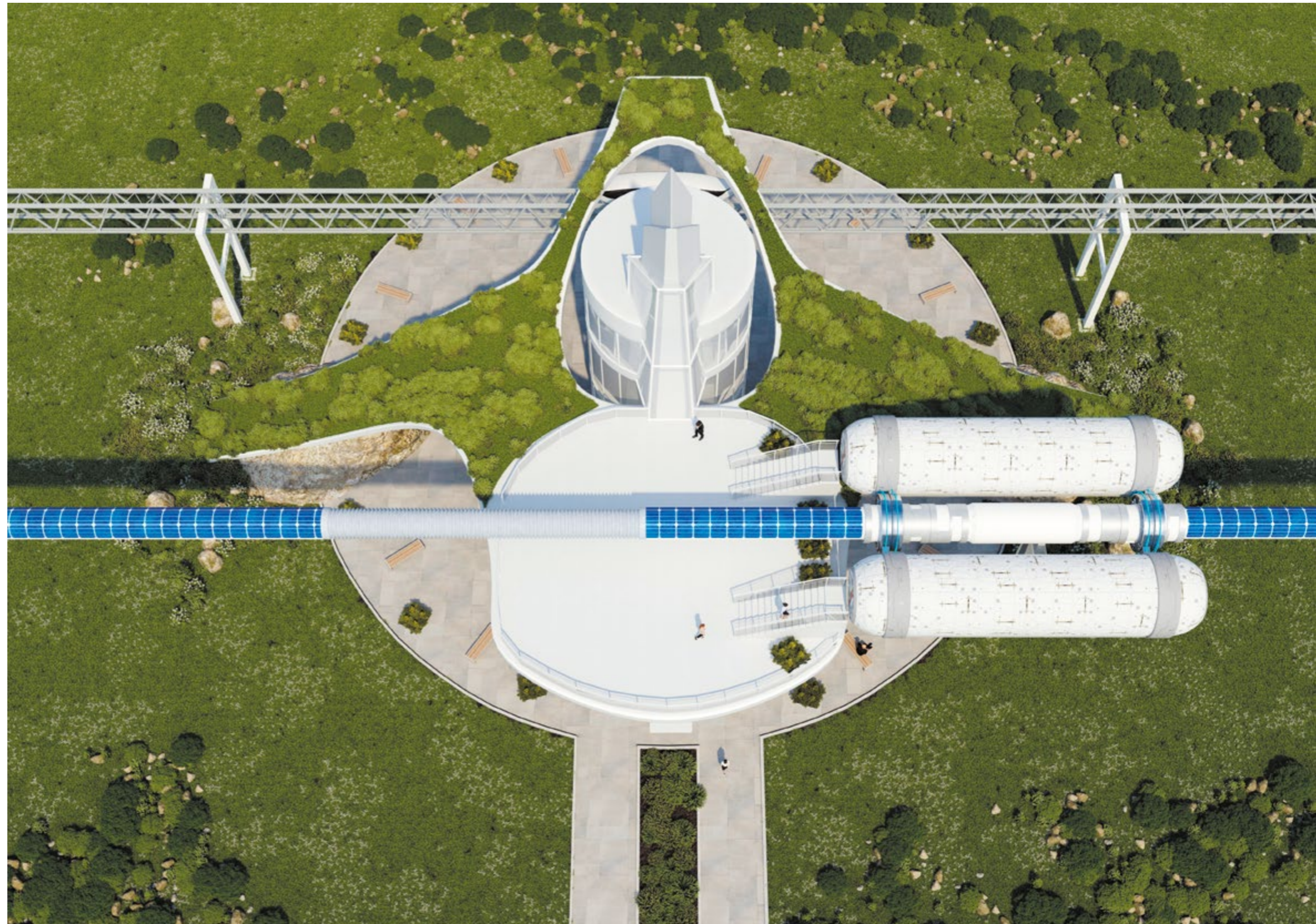



UDC 67.02

Technology of the Construction Material Production Using Household Appliances Waste

E. Zimina
Ph.D. in Engineering Sciences

N. Ulyanova
Ph.D. in Engineering Sciences

Vitebsk State
Technological University,
Vitebsk, Belarus

”

A technological scheme for concrete production with added glass chips obtained from household appliances is proposed in the article. This concrete is planned to be used for construction of the General Planetary Vehicle (GPV) takeoff and landing overpass encircling Earth in the equatorial plane. Recycling of failed glass appliances containing heavy metal ions is performed considering analysis of glasses from the TV kinescopes and identification of their chemical composition. The authors offer a technological process to prepare kinescope glass waste for production of construction materials, as well as a device for grinding glass into small size fraction that is necessary to provide optimal composition of concrete mix.

Keywords:

construction materials, equatorial overpass, glass, household appliances waste, innovative materials, kinescopes, recyclable materials.

Introduction

One of the fundamental directions of the global uSpace geocosmic program, focused on the non-rocket near space industrialization, is the construction of such a large-scale facility as the General Planetary Vehicle (GPV) overpass, which is a takeoff, landing, power and communication complex of the overpass type for geocosmic transportation, located along the equator and having a length of 40,076 km [1, 2]. Erection of this structure requires significant material costs, most of which are expenses for construction materials. In order to solve the issue of creating economical and environmentally friendly innovative materials, it is proposed to use a closed cycle (recycling) technology to process household waste accumulated by modern society.

E-waste is one of the main sources of environmental pollution, but it can be considered as a secondary resource as it contains valuable components. Hence, their reuse is not only an important element in the overall waste management structure but is also of interest in terms of material and resource potential.

Disposal of old equipment prevents the problem of buying a more modern and upgraded model or replacing one that has fallen into disuse. People often do not know what to do in this case with old household appliances. Proper organization of this process allows to solve many issues, including economic and environmental ones. From economic point of view, the disposal of household appliances is beneficial because it provides an opportunity to reuse materials in industrial production, in addition, some types of equipment contain a certain amount of precious metals. Moreover, plumbicon-type kinescopes and other glass devices contain heavy metal ions: lead, barium, strontium [3].

The main tasks of recycling production are collection, storage, transportation, sorting, neutralization, recycling or disposal of material. It has been established that the processes of decomposition and oxidation of metals lead to an extremely negative impact on all living organisms and the state of the soil; materials of low quality are often used in the manufacture of electronic circuits, and their decomposition results in a huge amount of poisonous toxic substances getting into the ground; the decay period of plastics can be up to 50 years, depending on the size of devices.

Problems of Recycling Household Appliances Waste

The growth of e-waste volumes is due to the increasing use of electronic equipment, shorter lifetimes and few repair

options. According to The Global E-waste Monitor, it can be noted that in 2019 the volume of e-waste in the world amounted to 53.6 mln tons (excluding solar panels), or about 7 kg per capita [4].

Expert V. Forthy from the United Nations University reports that Asia produced the largest amount of waste – 24.9 mln tons. Next come North and South America (13.1 mln tons), Europe (12 mln tons). The list is completed by Africa and Oceania (2.9 and 0.7 mln tons respectively). On a per capita basis, the data are as follows: Europe (16.2 kg) and Oceania (16.1 kg) lead the way. Asia (5.6 kg) ranks second to last [4, 5]. The volumes of e-waste production in different years are presented in Figure 1.

Today, the global growth of e-waste exceeds the rate of collection and recycling. Statistics show that the highest rate of waste collection is observed in Europe (45–48 %), where the Directive 2012/19/EU of the European Parliament and the Council on Waste Electrical and Electronic Equipment (WEEE) is in force. It defines the norms for recycling and recovery of WEEE [4].

The Republic of Belarus has adopted a legal act of general validity – the Law of July 20, 2007 No. 271-Z “On Waste Management”. At the same time, the sector of collection and recycling of e-waste is much better developed than in other European countries. Facilities for collection and acceptance of recyclable materials have been opened on the territory of the country, private collectors are working. In addition, e-waste is accepted in repair shops and service centers. In 2019, 23,000 tons of e-waste were collected in the Republic of Belarus [6].

In the framework of the international forum on waste management (The WEEE Forum), scientists noted that the volume of waste from gadgets around the world is growing rapidly. By 2030, this figure will reach 74.7 mln tons. Based on forecasts, by 2050 it may reach 120 mln tons, which is explained by the ever-increasing number of people who buy electronic products [5].

According to experts, the population will continue to throw away lamp and kinescope models of TV receivers until 2025 [7]. TV sets (kinescope, plasma and liquid crystal), personal computers and other devices have become widespread among e-waste in recent decades. The accumulation of such scrap is due to the fact that today the equipment is rapidly becoming obsolete.

The main environmental hazard is lead oxide, which is a component of kinescope glasses. Its amount in one kinescope depends on the size of the device and may vary from 0.5 to 2.9 kg.

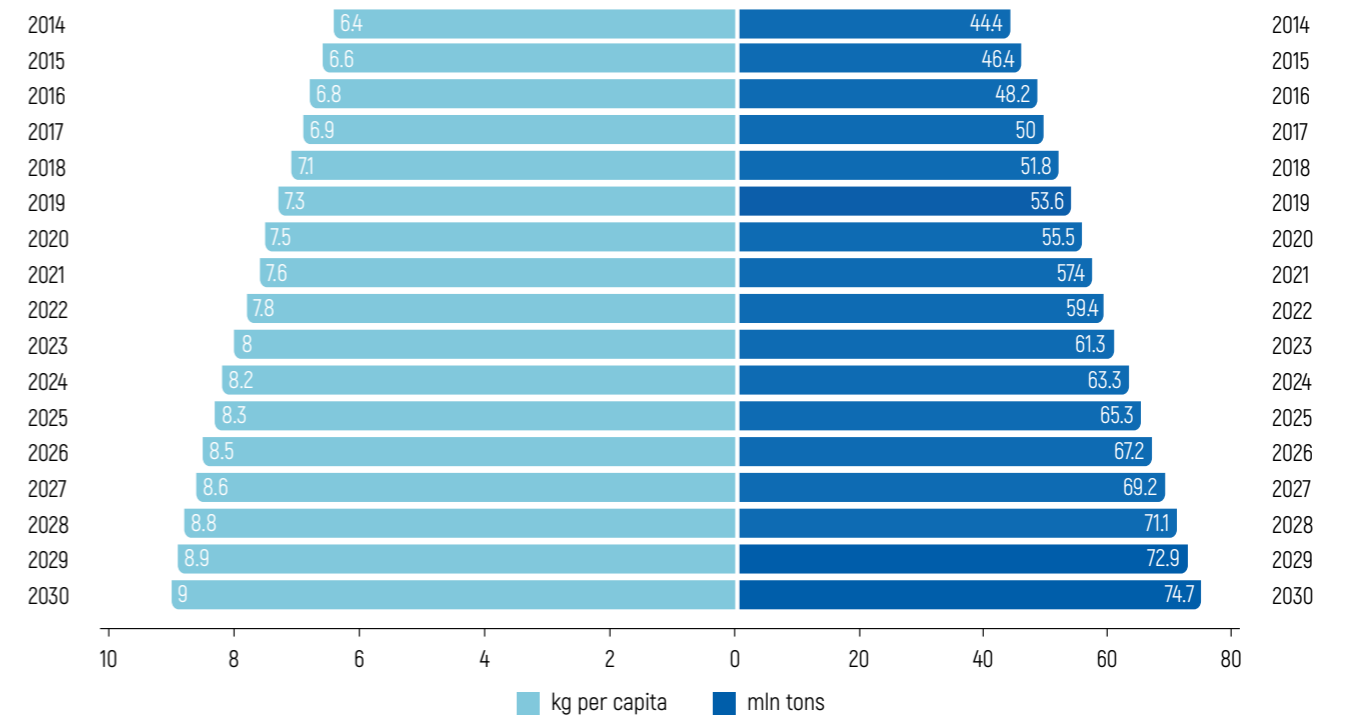

Figure 1 – E-waste volumes in 2014–2030 (future projections do not take into account economic consequences related to the COVID-19 crisis)

A peculiarity of the glass under study is that lead ions are relatively easily leached from the mass and released into the environment. For example, in case of improper processing of glasses containing heavy metals, leaching of lead ions may occur under the effect of organic acids, which are formed at the landfill for household waste. Glass cement is the most easily leached of all lead-containing components of the kinescope. Lead, like its compounds, is a toxicant with a pronounced cumulative effect, causing changes in the nervous system, blood and blood vessels. This fact implies the need for proper treatment of such glasses.

Thus, the researchers were posed with a task to develop a technological process of glass preparation for the purpose of its further application. TV kinescopes are chosen as the object. They are currently not used due to their complex composition, which is an acute problem for recycling enterprises.

Let us consider the components of the kinescope (Figure 2). On average, 87 % of its mass is glass of three grades, which includes strontium, barium and lead.

Four layers are applied to the inner surface of the screen. The first one is a carbon coating with various additives of surfactants. The second one creates a coating of luminophors, on which the third layer – a wax-like one – is applied to smooth

and protect the surface. The aluminum coating is the fourth layer, necessary to increase brightness. The inside of the kinescope cone has a layer of iron oxide and the outside has a layer of graphite. The screen and the kinescope cone are joined together using glass cement.

After disposal of the other parts, only the kinescope remains and needs to be separated into cone and screen due to their different chemical composition, which is important for their subsequent recycling.

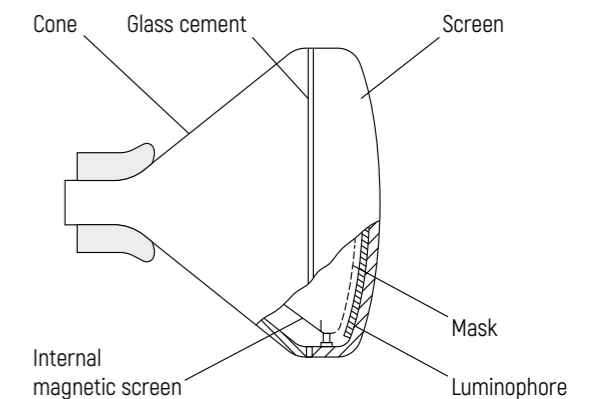

Figure 2 – Components of the kinescope

To determine the chemical composition of glass, the authors analyzed samples taken from the coating of kinescope glass. The methodology for determining the content of the main chemical components is set out in GOST 32362-2013 "Inorganic Glass and Glass Crystalline Materials. Determination of Chemical Composition. General Requirements for Methods of Determining the Content of the Main Chemical Components". The results of the study are presented in Table 1.

Table 2 shows the average chemical composition of kinescope glasses (the composition may vary depending on the TV manufacturer).

Analyzing the data of Tables 1 and 2, we can conclude: the presented samples do not correspond by 100 % to any chemical composition of glass specified in literature sources. This may be due to inaccurate splitting of kinescope glass by its types at the enterprise.

When glass is split, two of its types can be obtained – barium-strontium glass and lead glass.

Barium-strontium glass is used in the production of construction materials due to the low leachability of barium and strontium ions, the concentration of which does not exceed permissible standards.

The only and most common method of lead glass recycling is to use it as a recyclable material for lead production (flux is partially replaced by lead glass in metallurgical smelting furnaces). Alternative disposal methods are also proposed, which generally boil down to the idea of using glass to make building materials or as an additive in bricks, concrete, cement, decorative tiles, etc. Such materials with increased lead glass content may be suitable for protection against X-ray radiation. Lead glass is also needed in the ceramic industry to create leaching resistant glazes.

The main disadvantage of building materials with additives of crude lead glass is a decrease in their mechanical properties. In addition, it is found that the concentration of lead ions in most cases exceeds permissible standards.

In the Republic of Belarus, glass waste is used as a substitute for quartz sand in the production of construction materials, ceramic tiles, etc.

Thus, secondary application of kinescopes is allowed, but there is a need for their splitting, cleaning and recycling, which is possible only if there is special equipment at the enterprises for their disposal. That is why it is suggested that glass should be crushed and purified from harmful substances for further recycling and use.

Table 1 – Results of laboratory determination of the glass chemical composition, %

Substance	Chemical formula	Sample No. 1	Sample No. 2
Silicon oxide (silica)	SiO ₂	61.9	26.3
Aluminum oxide	Al ₂ O ₃	2.6	1.3
Lead oxide	PbO	6.6	38
Zinc oxide	ZnO	0.1	0.5
Sodium oxide	Na ₂ O	5.5	6
Potassium oxide	K ₂ O	7	8
Calcium oxide	CaO	0.5	1.9
Iron oxide	Fe ₂ O ₃	0.1	0.1
Strontium oxide	SrO	6	8.1
Barium oxide	BaO	9	9
Other oxides	-	0.7	0.8

Table 2 – Average chemical composition of kinescope glasses, %

Substance	Chemical formula	Screen and cone (black-white TV)	Lead-containing screen	Screen	Cone	CRT glass	Glass cement
Silicon oxide	SiO ₂	65	44.2	62	52	33.7	2
Aluminum oxide	Al ₂ O ₃	3	1.5	2.2	4	1.8	-
Lead oxide	PbO	4	4.2	-	22	39.4	75
Zinc oxide	ZnO	0.1	0.5	0.3	-	-	11
Sodium oxide	Na ₂ O	7	6	8	6.8	5.6	-
Potassium oxide	K ₂ O	7	11.5	7	7.8	8.6	-
Calcium oxide	CaO	0.5	2.5	0.5	3.8	4.3	-
Magnesium oxide	MgO	-	0.2	0.2	1.8	1.4	-
Iron oxide	Fe ₂ O ₃	0.1	0.1	0.08	0.1	1	-
Strontium oxide	SrO	1	16.8	8	0.5	0.2	-
Barium oxide	BaO	11	10.9	10	1	-	2
Boron oxide	B ₂ O ₃	-	-	-	-	3.5	9
Other oxides	-	1.3	1.6	1.72	0.2	0.5	1

Technological Process of Glass Grinding

After sorting from plastic, the glass goes to the crushing area to be split into coarse fractions using hammer crushers.

Piece sizes of the first grade glass scrap should be 10-50 mm. In the batch of glass scrap it is allowed to contain the pieces with the size over 50 mm – not more than 5 %; with the size less than 10 mm – not more than 1 %. The size of pieces of the second grade glass scrap is not standardized, the weight of pieces – not more than 2 kg.

Due to the fact that the fraction of pieces in the batch after the first crushing is heterogeneous, it is necessary to continue further crushing to homogeneity – grinding. For this purpose, it is proposed to use a rotary crusher (the authors' own development), the layout of which is shown in Figure 3.

The rotors are gears rotating towards each other at the same speed.

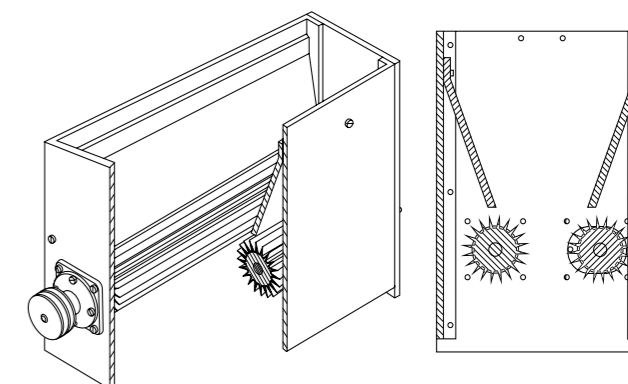

Figure 3 – Rotary crusher

The glass mass is fed to the rotors via an inclined chute and is directed into the gap between them by the friction force arising from contact with the surface of the rotors.

The glass is crushed to homogeneous fractions due to friction forces and impact loads.

Let us consider the condition of pulling the glass into the gap (Figure 4). The following forces act on the material: G – gravity force of the material, N ; N_1 , N_2 – reaction forces of the rotors, N ; T_1 , T_2 – friction forces of the material on the surface of the rotors, N . The values α_1 , α_2 – angles of mass capture by the rotors – depend on the angle of inclination of the shaft walls and the distance between the plates; v – linear speed of rotation.

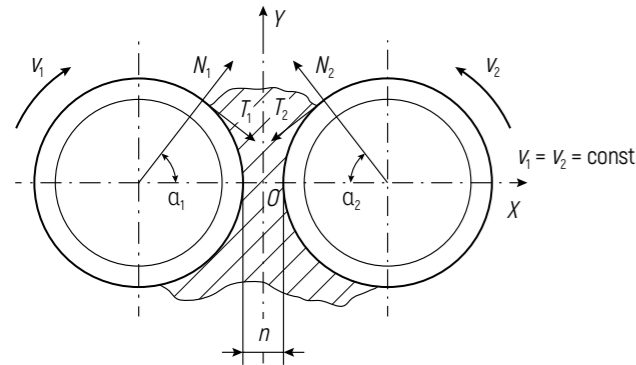

Figure 4 – Diagram of pulling the material with rollers

The material undergoes in the gradually narrowing space increasing deformation, stretching and compressive stresses, which are increased by the rotation of the rotors.

The friction forces are determined from the following dependencies:

$$T_1 = T_2 = N_1 f_1 = N_2 f_2 = N_1 \operatorname{tg} \beta_1 = N_2 \operatorname{tg} \beta_2, \quad (1)$$

where f_1 , f_2 – friction coefficients of material against the rotors surface;

β_1 , β_2 – friction angles of material against the rotors surface, °.

The values β_1 , β_2 depend on the viscosity of the glass mass.

Let us make an equilibrium equation of the force projection magnitude on the OX axis; we assume that the center of coordinates is in the middle of the gap:

$$F = G - N_1 \sin \alpha_1 + N_2 \sin \alpha_2 + T_1 \cos \alpha_1 + T_2 \cos \alpha_2, \quad (2)$$

where F – the force of pulling the material into the gap, N .

Substituting the values of T_1 , T_2 , we obtain:

$$F = G - N_1 (\sin \alpha_1 + \cos \alpha_1 \operatorname{tg} \beta_1) - N_2 (\sin \alpha_2 + \cos \alpha_2 \operatorname{tg} \beta_2). \quad (3)$$

If we assume that

$$\alpha = \alpha_1 = \alpha_2 \text{ and } \beta = \beta_1 = \beta_2, \quad (4)$$

the force of drawing the material into the gap between the rotors is equal to:

$$F = G - 2N (\sin \alpha + \cos \alpha \operatorname{tg} \beta). \quad (5)$$

Then the mass of glass pulling by rotors at $G = mg$ is:

$$m = \frac{F + 2N (\sin \alpha + \cos \alpha \operatorname{tg} \beta)}{g}, \text{ kg.} \quad (6)$$

The performance of the device and the particle size at the outlet depend on the distance n between the distributing rotors:

$$P = \frac{60}{1,000} \rho S_g V_{shaft}, \text{ kg/s,} \quad (7)$$

where ρ – product density, kg/m^3 ;

S_g – area of the gap between the distributing rotors, m^2 ;

V_{shaft} – rotation speed of distributing rotors, m/s .

$$S_g = bn, \quad (8)$$

where b – length of distributing rotors, m .

The grinding process produces chips of a homogeneous fraction of 0.4–5 mm, which must then be chemically treated.

Technological Process of Glass Purification from Harmful Impurities

Cleaning from Luminophors

After separation of fractions, the obtained glass powder is treated for 10–30 min with a detergent solution, which is an aqueous hydrochloric acid solution (concentration 0.01–0.9 of the total mass). The luminophore settled down to the bottom of the container is rinsed, dried, sifted and sent for reuse. As a result of treatment of the glass scrap with aqueous acid solution there occurs separation

of luminophore from glass surface; the utilized luminophore does not differ from the initially used luminophore by granulometric composition and light-technical properties. Then the glass scrap is rinsed with water to clean the glass from traces of luminophore and mineral acid. Thus, the output is a mixture of two types of glass – lead glass and barium-strontium glass.

Cleaning from Lead

To date, the only and most widespread method of lead glass recycling is its use as a recyclable material for lead production. For this purpose, metallurgical smelting furnaces are applied, in which flux is partially replaced with lead glass. The furnace is heated with the help of electricity, and lead glass (chips up to 3 mm in size), precrushed and mixed with the melt of oxysulfate paste, is used as a raw material. After the reduction process at 1,200 °C, the output is lead granules and glass.

The second way to clean glass from lead particles is its special chemical treatment, the essence of which is the preliminary leaching of this substance. The extraction process is usually carried out with nitric acid for 1 h, then the crushed glass is rinsed and dried. The products of leaching are then sent to a chemical plant for further processing, and the resulting glass chips can be used in building materials.

Production of Concrete Using Purified Glass Scrap

Concrete containing fillers in the form of glass chips is superior to the traditional construction mix. The main advantages of glass concrete are:

- reduced weight (main fillers are cement, glass fiber (glass), sand);
- increased strength (glass-filled composite is characterized by resistance to deformations, and the parameters of impact resistance exceed the characteristics of concrete mortar by 15 times);
- extended area of application and a wide range of manufactured products;
- a significant number of possible additives that have a versatile effect on the characteristics of the resulting building materials.

However, incorrect proportions of components significantly reduce the strength of glass concrete.

Dosing of Concrete Mixture Components

The degree of homogeneity of the mixture is an indicator of mixing efficiency. According to the definition previously adopted in the domestic literature, the intensity of the mixing device (also known as mixing intensity) is characterized by the following values:

- the time of achieving a specific technological result at a constant rotational frequency or the rotational frequency (peripheral speed of mixing blades) of the mixing mechanism at a constant process duration;
- the power used for mixing, applied per volume unit or weight of the material to be mixed.

The building of concrete structures requires technological equipment that guarantees the production of concrete mixtures with the required properties and concrete with the specified design characteristics.

When selecting the technological equipment according to specific types of concrete and peculiarities of the applied technology, it is necessary to be guided by the following provisions.

The following items are used in the technology realized by the premixing method:

- serial mixing equipment of domestic production;
- spiral-vortex mixers;
- bar-screw mixers;
- imported mixers of premixing.

Serial technological equipment for the manufacture of conventional reinforced concrete structures can be used for vibro-compaction of concrete mixtures, including with tightening weight and vacuumization.

The technology of preliminary blending the mixtures (premixing) with subsequent compaction through various technological methods is recommended for mass production of precast concrete structures in factory conditions with a relatively small nomenclature of products and significant production volumes.

When implementing the technology of manufacturing concrete structures by premixing method, it is necessary to consider the peculiarities of arrangement of embedded parts in them.

The technological diagram of the pilot line for the production of concrete sheet elements with the addition of glass chips is presented in Figure 5.

An experiment was conducted in order to determine the optimal mixture composition using kinescope glass waste.

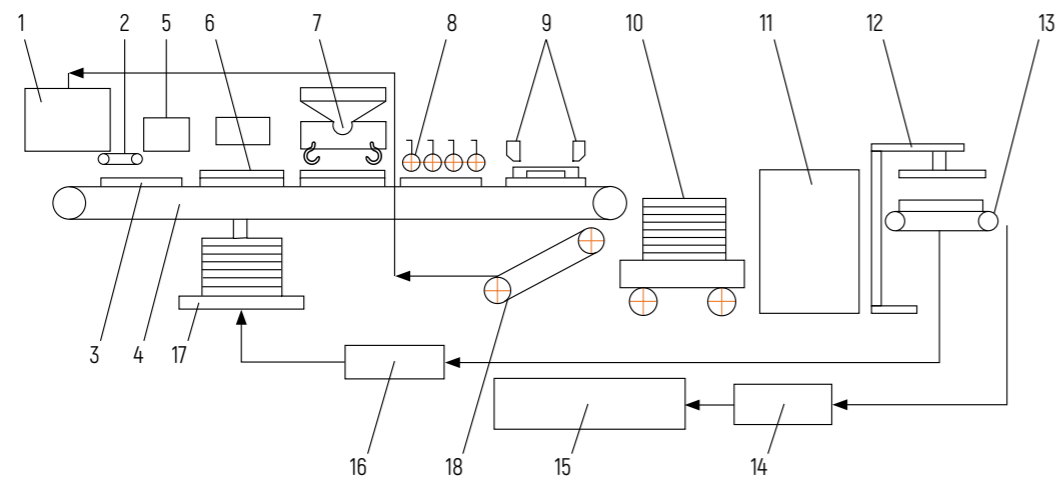

Figure 5 – Technological diagram of the pilot line for the production of glass concrete sheet elements:
 1 – mixing unit; 2 – feeder-doser; 3 – mixture laying pallet; 4 – product molding conveyor; 5 – leveler; 6 – product molding pallet; 7 – tip-over device;
 8 – vibration rollers; 9 – clippers; 10 – cart; 11 – prehardening chamber; 12 – demoulder; 13 – conveyor; 14 – wet hardening conveyor;
 15 – finished product warehouse; 16 – pallet cleaning and lubrication station; 17 – relocater; 18 – mobile feed conveyor for primary materials

The initial volume composition of the concrete mixture: one part – cement, 2.6 parts – sand, 4.5 parts – crushed stone. In our case, glass chips were additionally added to the mixture – 0.4–1.2 parts of the resulting mass of the mortar. The ratio of introduced sand and glass chips is proportional but not more than 2.6 parts. The composition of mixtures made for the study is presented in Table 3.

According to the state standard, concrete mixtures are characterized by the following technological quality indicators: workability, average density, delamination, porosity, temperature, time stability of properties, volume of air involved. During testing, the quality of the mixture is determined by its shrinkage and air pore content, while the quality of the hardened mixture is assessed by the values of compressive strength

limit after 28 days. In addition, the weight of the samples after storing is measured. The finished material must acquire the design strength by a certain date and have the necessary properties according to the purpose of the manufactured structure: water resistance, frost resistance, density and others.

To obtain high quality products, it is necessary that the concrete mixture has a consistency that corresponds to the methods of its placement and compaction. The consistency of the mixture is evaluated by its mobility or stiffness. The mobility of the mixture is its ability to spread under its own weight. To determine this parameter, a cone is used, which is filled with the mixture layer by layer in three steps, compacting it by rodding [Figure 6] [8].

Table 3 – Composition of mixtures for the study

Sample	Composition, parts			
	Cement	Crushed stone	Sand	Glass chips
No. 1	1	4.5	2.6	-
No. 2	1	4.5	2.2	0.4
No. 3	1	4.5	1.8	0.8
No. 4	1	4.5	1.4	1.2

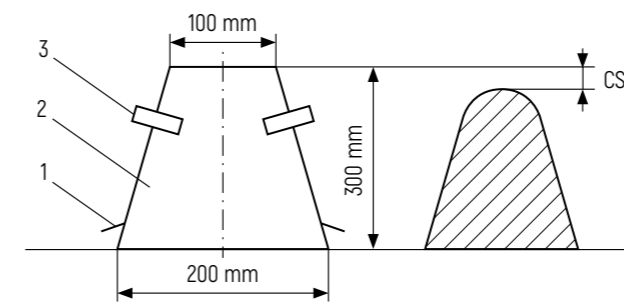

Figure 6 – Determination of mixture workability by cone sediment:
 1 – supports; 2 – cone; 3 – handles; CS – cone sediment

Table 4 shows the normative and experimental values of cone sediment and the grade of the mixture meeting these values. The grade indicates the mobility of the mixture when paving: P1, P2, P3 – low-mobility; P4, P5 – with high mobility.

Table 4 – Normative and experimental values of cone sediment

Sample	Sample cone sediment, cm	Normative index of cone sediment for different grades, cm				
		P1	P2	P3	P4	P5
		1–4	5–9	10–15	16–20	Above 20
No. 1	10			+		
No. 2	10			+		
No. 3	11			+		
No. 4	12			+		

Table 5 – Experimental parameters of samples

Sample	Weight, g		Destructive load, kN	
	before storing	after storing	before storing	after storing
No. 1	2,360	2,300	112	158
No. 2	2,340	2,280	124	164
No. 3	2,335	2,214	118	160
No. 4	2,320	2,200	108	142

According to the obtained data, the experimental mixtures correspond to P3. It means that all samples are of low-mobility type, i.e., their consistency is thick. Mixtures of such grades should be used for the construction of monolithic structures. When filling them, vibrators must be employed.

Class (grade) of concrete is characterized by its strength, which is determined by compression of samples with a rib of 150 mm, made of the working mixture after their hardening for 28 days in normal conditions. Normal conditions of hardening of the material are considered to be relative humidity of 90–100 % and temperature $[20 \pm 2] ^\circ\text{C}$. High air humidity is necessary to avoid evaporation of water from the mixture, which can lead to termination of hardening. The hardening of the material accelerates with a rise in temperature and slows down with its fall. The experimental parameters of samples are presented in Table 5.

It should be noted that the samples with the introduction of glass chips slightly decreased in weight but increased in strength. However, in case of adding chips in the ratio with sand almost 50/50, the strength decreased.

The economic effect of the technology under consideration is to increase the strength of concrete mixtures and expand the scope of using kinescope glass waste.

The test results (Table 6) showed that the samples with the addition of glass waste in terms of strength correspond to concrete of C₁₀ grade according to STB 1544-2005 "Structural Heavy Concrete. Technical Conditions". The strength of the samples increased by 0.6–2.7 MPa (4.8–21.6 %).

Thus, the use of glass waste in concrete products will increase the compressive strength of concrete, which will allow saving cement and sand (with the same strength indicators of the structure). In addition, thanks to the proposed technology, the repair-free period will increase, which is especially important in the construction of such a large-scale facility as the GPV equatorial launch overpass.

Conclusion

E-waste recycling is not only a significant element in the overall waste management structure but is also of interest in terms of material and resource potential. It is noted that e-waste is a significant source of environmental pollution, however, it can be considered as a secondary resource as it contains valuable components. One of such components is glasses used for optical application, TV kinescopes, monitor screens, which have a complex composition for their further recycling.

This article presents a technological process for the preparation of glass waste from kinescopes for the production of reinforced building materials – by the method of mixing and vibration.

A device for grinding glass into a fine fraction, providing its uniform mixing with concrete mortar, is proposed, and the optimal composition of the concrete mortar is determined.

Table 6 – Results of tests on samples

Standardized strength and density characteristics of concrete			Sample characteristics			Test results			
Concrete strength class	Required strength at sample testing, MPa	Specified delivery strength, MPa	Weight, g	Dimensions, cm	Average density, kg/m ³	Destructive load, kN	Sample strength, MPa	Sample strength deviation	
								MPa	%
C ₁₀	12.9	9	2,360	10 × 10 × 10	2,360,000	112	10.7	-2.2	-17.3
			2,300		2,300,000	158	15	+2.1	+16.6
			2,340		2,340,000	124	11.8	-1.1	-8.5
			2,280		2,280,000	164	15.6	+2.7	+21.6
			2,335		2,335,000	118	11.2	-1.7	-12.9
			2,214		2,214,000	160	15.2	+2.3	+18.1
			2,320		2,320,000	108	10.3	-2.6	-20.3
			2,200		2,200,000	142	13.5	+0.6	+4.8

It was found that concrete structures produced from mixtures of new formulations have an advantage over conventional ones – the compressive strength increases by 0.6–2.7 MPa (4.8–21.6 %).

The use of the considered technology, assuming the introduction of a stabilizing additive in concrete, will reduce material costs for the production of the GPV launch overpass and at the same time improve the strength characteristics of the object to be erected.

References

1. *Non-Rocket Near Space Industrialization: Problems, Ideas, Projects: Collection of Articles of the V International Scientific and Technical Conference, Maryina Gorka, Sep. 23–24, 2022 / Astroengineering Technologies LLC, Unitsky String Technologies Inc.; ed. A. Unitsky. – Minsk: StroyMediaProject, 2023. – 320 p.*
2. *Unitsky, A. The Engineer: Autobiography / Anatoli Unitsky. – Minsk, 2020. – 400 p.: ill.*
3. *Yel'yashkevich, S.A. Televizory 3 USTsT, 4 USTsT, 5 USTsT. Ustroystvo, regulirovka, remont [TV Sets 3 USCT, 4 USCT, 5 USCT. Device, Adjustment, Repair] / S.A. Yel'yashkevich, A.Ye. Peskin. – Moscow: Simvol-R, 1993. – 223 p.*
4. *The Global E-waste Monitor 2020. Quantities, Flows and the Circular Economy Potential [Electronic resource] /*

V. Forti [et al.]. – Mode of access: <https://www.tadviser.ru/images/3/3f/The-Global-E-waste-Monitor-2020-Quantities-flows-and-the-circular-economy-potential.pdf>. – Date of access: 08.04.2023.

5. *10 faktov ob elektronnom musore [10 Facts About E-waste] [Electronic resource]. – Mode of access: <https://plus-one.ru/ecology/2021/04/20/10-faktov-ob-elektronnom-musore>. – Date of access: 08.04.2023.*
6. *"Otnositel'no progressivno". Vyshe! doklad OON po elektronnomu musoru, tam yest' i pro Belarus' ["Relatively Progressive". The UN Report on E-waste Has Been Released, and It Includes Belarus As Well] [Electronic resource]. – Mode of access: <http://wasteinfo.by/news/otnositelno-progressivno-vyshe!-doklad-oon-po-elektronnomu-musoru-tam-est-i-pro-belarus>. – Date of access: 08.04.2023.*
7. *Utilizatsiya televizorov [Disposal of TV Sets] [Electronic resource]. – Mode of access: <https://musor.moscow/%20blog/utilizatsiya-televizorov/>. – Date of access: 08.04.2023.*
8. *Zimina, A.L. Analiz vozmozhnosti ispol'zovaniya otkhodov logkoy promyshlennosti v proizvodstve materialov stroitel'nogo naznacheniya [Analysis of Light Industry Waste for the Production of Clothing Materials for Construction Purpose] / A.L. Zimina // Vestnik Vitebskogo gosudarstvennogo tekhnologicheskogo universiteta. – 2016. – No. 2 [31]. – P. 39–46.*



Options for Use of Electrohydraulic Discharge Equipment in the Conditions of Human Habitation in Space

A. Unitsky^{1,2}

Dr. of Philosophy
in Information Technologies
(Transport)

N. Pershai²

Ph.D. in Engineering Sciences

S. Arnaut²

Ph.D. in Engineering Sciences

¹ Astroengineering Technologies LLC,
Minsk, Belarus

² Unitsky String Technologies Inc.,
Minsk, Belarus



Technological solutions for the use of electrohydraulic discharge equipment (EHDE) in the conditions of human habitation in space are considered to ensure the environmental safety of enclosed ecosystems. The proposed technological schemes are based on experimental data obtained on the UniThorr EHDE developed by the employees of Unitsky String Technologies Inc. The results of grinding brown coal through the electrohydraulic effect are presented (for the production of potting soils in order to increase soil fertility) as well as the technology of disinfection in a closed-loop system of water disposal and water consumption, including the preparation of recycled water for growing aquaculture (using the example of fish) in the artificially created environment of the EcoCosmoHouse (ECH).

Keywords:

aquaculture, brown coal, EcoCosmoHouse (ECH), electrohydraulic discharge equipment (EHDE), electrohydraulic effect, electrohydraulic shock, grinding of natural materials, Industrial Space Necklace "Orbit" (ISN "Orbit"), potting soil, water disinfection.

Introduction

The development of enclosed ecosystems dates back to the very beginning of space exploration by human. This kind of research have begun more than 60 years ago and continues to this day, actively gaining momentum. This is due, firstly, to the increased interest not only of the world's states but also of private companies in space exploration, and secondly, to the aggravation of global problems of our time, shortage of human and natural resources, climatic disasters, wars, overpopulation of the planet, etc. [1, 2].

Engineer A. Unitsky has developed a concept for the construction of the Industrial Space Necklace "Orbit" (ISN "Orbit"). This is a multi-orbital transport, infrastructure and industrial-residential complex covering the planet in the equator plane and serving the Earth's humanity. It will become a functional analog of the Equatorial Linear City, a kind of a foothold in case of various cosmic threats, including meteorites, as well as a technological platform for deep space exploration [1-3].

The structure of ISN "Orbit" presumes the construction of EcoCosmoHouses (ECHs), which are enclosed ecosystems of biospheric type, where all residents should be provided with balanced nutrition and quality drinking water [4-7]. In such an environment, the need to create enclosed systems becomes acute. They should be characterized by full cycles of self-supply of people with all necessary things: food, water, oxygen, etc.

The ECH functioning technologies should support comfortable conditions for the stay of people. In particular, the following are mandatory:

- constant supply of sufficient oxygen to residents;
- comprehensive air purification from harmful impurities;
- humidity control;
- control of compartment tightness;
- detection and extinguishing of fires;
- delivery and storage of water, its regeneration and purification;
- food supply, including food storage, food waste processing;
- hygienic control and sanitation [8].

The process of creating a full-fledged, fully autonomous and enclosed ecosystem is very complicated, and no 100 % successful experiments of this kind have been reported to date [9-11].

When developing enclosed ecosystems, it is necessary to give preference to equipment and technologies, the operation principle of which is based on the use of electric power.

This is due to the fact that there is an inexhaustible source of solar energy in outer space that can be converted into electrical energy, which does not require the delivery of natural fossils from Earth [12]. Consequently, an electrohydraulic discharge equipment (EHDE) in Earth's orbit will be a good alternative to the traditional and widely used equipment applied on our planet. It should be noted that the arrangement of a human settlement in space makes it difficult to deliver any cargo from Earth, therefore, the most preferable technologies are those that imply the possibility of creating an enclosed cycle with a full autonomy.

The use of EHDE in industry is quite diverse [13]. There are more than 35 known directions of application of the unit in such spheres as mechanical engineering, mineral extraction, construction, mining engineering, medicine, agriculture, ecology, power engineering as well as for crushing of glass sludge, ferromagnets, vegetable waste, peat, precious stones, nonmetallic and other materials, ore beneficiation, extraction of residual minerals from dumps, destruction of various objects (rocks, reinforced concrete structures, foundations, ice, frozen rocks), mechanic activation of construction materials, mixing solutions, cleaning surfaces, water disinfection, increasing soil fertility, etc.

A good alternative to traditional methods of grinding and disinfection in the process of creating enclosed systems intended for implementation in ECH can be the use of EHDE. The principle of its functioning is based on the electrohydraulic effect (Yutkin effect), the essence of which is the conversion of electrical energy into mechanical one with a high efficiency factor. It occurs due to the fact that a specially formed pulse electric discharge flows inside the liquid volume. Around its zone, ultrahigh pulse pressures appear; they are capable of doing mechanical work and are accompanied by a complex of physical and chemical phenomena [13].

One of the main advantages of the introduction of electrohydraulic discharge technology in the conditions of cosmic life is environmental friendliness, which is dictated by the absence of additional introduction of chemicals, formation of by-products.

The purpose of this work is to investigate possible ways of using the EHDE during long-term stay of people in the enclosed ecosystem of the ECH. Due to the fact that there are a lot of directions of the EHDE application, three of them were chosen related to the provision of food and water to the residents.

The first direction is the use of the unit for grinding of natural materials, in particular, brown coal as a component

of light potting soil intended for growing plants in the ECH [14, 15]. In [13, 16], the authors propose to add waste and plant residues after grinding as nutrients into soil in space conditions. Within the framework of this direction, it is planned to expand research on the shredding of natural materials using the EHDE.

The second direction is disinfection of water after wastewater treatment, which, depending on its quality, can be applied for domestic and technological needs, irrigation of plants, etc. [17, 18].

The third direction is the use in closed-type installations for aquaculture, in particular, fish cultivation [19, 20].

According to the set goal, the following tasks were tackled:

- determination of the impact of different parameters of the EHDE operation on the grinding of natural materials on the example of brown coal as a component of potting soil intended for plant cultivation;
- determination of the effect of electrohydraulic shock on the death of microorganisms and algae in the circuits of purification and treatment of drinking and waste water as well as in enclosed systems of fish cultivation.

Modifications to the traditional schemes for obtaining potting soil, wastewater and fisheries water treatment are proposed based on the results achieved.

Description of the UniThorr EHDE Operation

The study was carried out on the UniThorr EHDE (Figure 1) created by the employees of Unitsky String Technologies Inc. (Minsk, Belarus). The main components of the unit are the pulse current generator and the working chamber. The latter is a container with a treated material, process fluid as well as negative and positive electrodes inside.

A simplified wiring diagram of the UniThorr EHDE is shown in Figure 2.

The unit functions as follows. A capacitor battery is charged from a high-voltage transformer through a rectifier and a charging resistor. When the required voltage is reached, voltage is applied to the positive electrode located in the working chamber via an air gap. Closure of the discharge gap is accomplished by a spark breakdown in the liquid between the positive and negative electrodes located inside the working chamber. The negative electrode is a metal plate embedded in the bottom of the chamber; the positive electrode is a dielectric pencil with a metal rod inside.

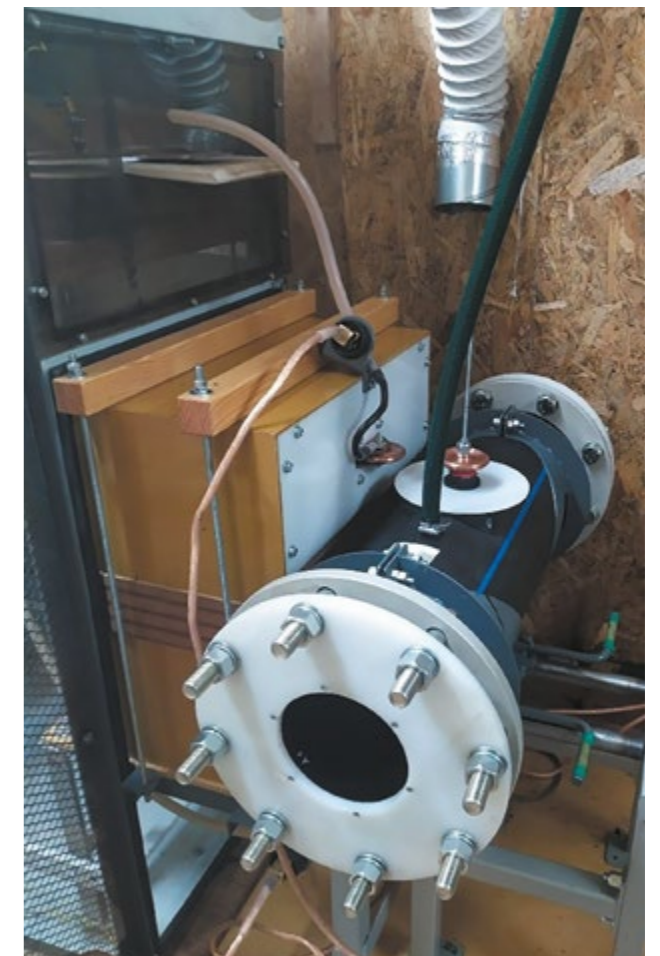

Figure 1 - The UniThorr EHDE

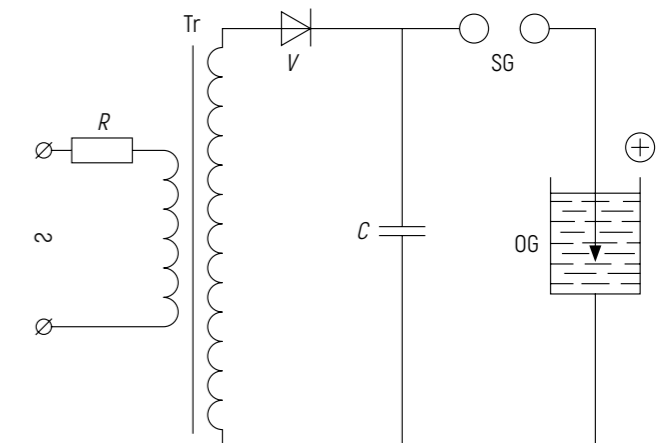

Figure 2 - A simplified wiring diagram of the UniThorr EHDE:
R - charging resistor; Tr - transformer; V - rectifier;
SG - shaping spark gap; OG - operating spark gap;
C - operating capacitance of condenser

Application of the UniThorr EHDE to Obtain a Light Potting Soil Component

For a wholesome and qualitative stay of people in the ECH it is necessary to provide them with a balanced diet. It means that it should be obligatory to provide for the possibility of plant food in the enclosed ecosystems. Various technologies of plant cultivation under the conditions of outer space are being developed for this purpose. Experiments are described in [15], and the composition of light potting soil was selected for the ECH using UniTerra ameliorant-soil improver created on the basis of brown coal processing [21]. In addition, UniTerra contains humic substances and soil microorganisms. All these components are considered to be important factors for the formation of highly fertile soil [15].

The scheme of processing solid food waste to cultivate plant products is presented in [16]. In this process, the mandatory stage is their dispersion, i.e., crushing of solid particles (plant residues, sewage sludge, food waste, excrements, etc.) in a liquid medium. The EHDE can act as a dispersant here, but it is necessary to select technological modes of operation of the unit, which is planned to be carried out during further research.

The authors of this article studied the impact of electrohydraulic shock on brown coal grinding, determined the main parameters of the crushing process in order to select the optimal technological modes of operation of the EHDE.

One of the advantages of the unit application for brown coal grinding in liquid medium is that the electrohydraulic impact (slurry treatment) leads to an increase in nitrogen content, improves the solubility of chemical substances, converts them into a form digestible for plants; the resulting slurry can additionally serve as a nutrient solution [13, 22].

Brown coal of B1 grade from two deposits (Russian and Kazakhstani) was used for the research. The range of initial fraction was 0–50 mm. Tap water was applied as a working fluid. Its volume in the discharge chamber depended on the ratio of coal and water as well as on the mass of loading.

Brown coal in the form of coal-water suspension was placed in the working chamber and processed for a certain time (up to 60 min). After a preset interval (2–10 min) sampling selection was carried out. A granulometric analysis of samples by sieve method was conducted according to [23]. The method of laser diffraction with the help of the Malvern Mastersizer 3000 was used for quantitative estimation of smaller particles.

The conducted studies showed efficient crushing of brown coal within 5–10 min depending on the nature of raw materials and the mass of loading (Figure 3).

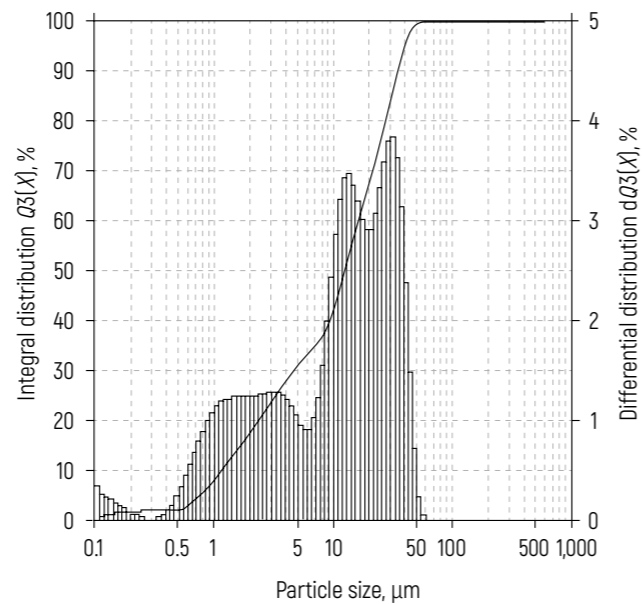

Figure 3 – Integral and differential distribution of brown coal particles after grinding at the UniThorr EHDE for 10 min

It was found that treatment for more than 10 min does not lead to a significant increase in the proportion of particles smaller than 100 μm. This is probably due to the fact that during prolonged exposure in discrete chambers two opposite processes occur – grinding and coagulation. The process of coagulation will be excluded at crushing in the chamber of continuous mode of the EHDE operation with the withdrawal of suspension with particles less than 250 μm.

Micrographs of grinded brown coal (Figure 4) show homogeneity of particles with fraction sizes less than 100 μm, inclusions of mineral content are visible. The increase of processing time of fractionated feedstock (fraction of 3–5 mm) leads to obtaining particles of more uniform and rounded shape.

Further studies of the structure and chemical composition of brown coal samples were carried out by the method of scanning electron microscopy with an electron-probe X-ray fluorescence energy dispersive chemical analysis (scanning electron microscope JSM-5610LV with chemical analysis system JED-2201, JEOL, Japan).

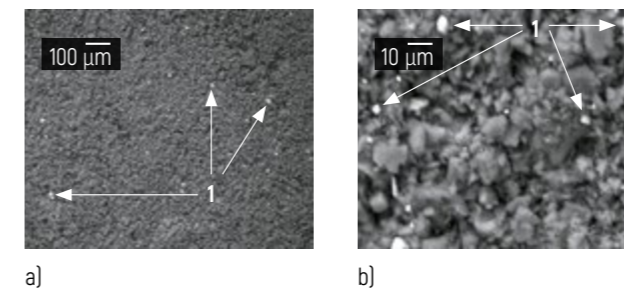

Figure 4 – Electron-microscopic images of brown coal sample structure (initial fraction of 3–5 mm) with particle size less than 100 μm after grinding for 10 min: a – 100 times magnification; b – 1,000 times magnification; 1 – inclusions of mineral content

When using initial unfractionated brown coal (fraction of 0–50 mm), deterioration of grinding quality is observed even when increasing the grinding time up to 15 min, and the particles have a more elongated shape and high heterogeneity of composition (Figure 5).

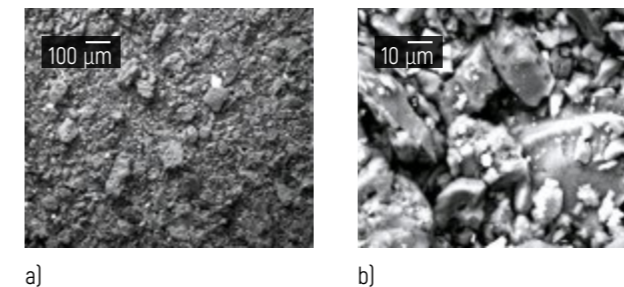

Figure 5 – Electron-microscopic images of brown coal sample structure (initial fraction of 0–50 mm) after grinding for 15 min: a – 100 times magnification; b – 1,000 times magnification

Studies have shown that there are no significant differences between the results of grinding of coal fraction with particle sizes of 3–5 mm and 7–50 mm. In this regard, the experiments were conducted with the initial coal fraction of 7–50 mm, since the particles of larger size are destroyed quickly enough and further grinding occurs at the same rate as for the fraction of 3–5 mm.

In addition, it is experimentally confirmed that at the beginning stage of treatment of the physical and chemical properties of coal influence the operation of the unit and require adjusting the technological process taking into account the specifics of the initial material. However, the final result

of grinding after the adjustment of EHDE parameters is identical. This suggests that the setting of the unit should be carried out for a particular raw material and corrected only when its features change. The choice of the operating mode of the EHDE is primarily determined by the specific electrical conductivity of the coal-water suspension, which depends on the content of water-soluble mineral substances in brown coal (Figure 6).

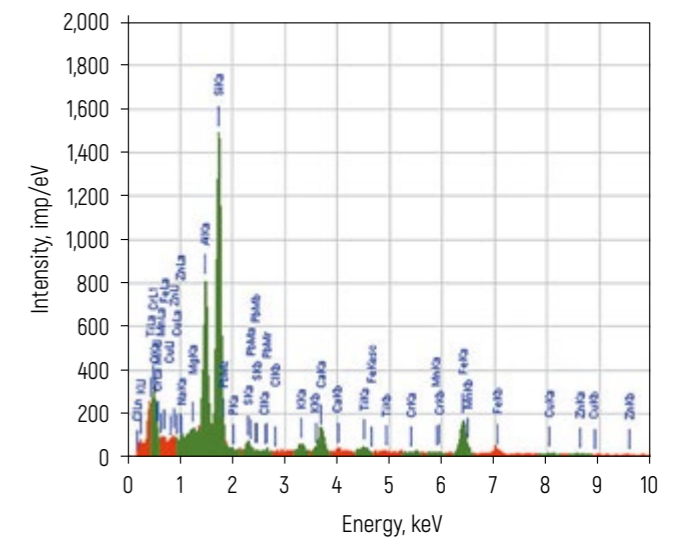

Figure 6 – The result of electron-probe chemical analysis of brown coal ash residue

The increase in specific electrical conductivity causes deterioration of the pulse quality, i.e., the appearance of the so-called idle discharge, and leads to a decrease in the efficiency factor of the unit due to the fact that the useful work of the pulse goes not to crushing of the material but to heating of the working medium.

It was experimentally determined that during the operation of the EHDE specific electrical conductivity increases due to the transition of water-soluble mineral components of raw materials into an aqueous solution (e.g., ash content of the Kazakhstani brown coal decreases by up to 40 % depending on the processing time) (Table). In addition, grinding of brown coal at the EHDE to produce fertilizers by alkaline extraction of humic acids (HA) leads to an increase in the total yield of humic substances by 18–27 %, which is most likely due to the breakage of chemical bonds during grinding and growth in their lability. At the same time, the mass fraction of fulvic acids (FA) increases in comparison with HA.

Table – The change of brown coal parameters after processing at the UniThorr EHDE

Raw material	Processing time, min	Number of pulses, pcs	Ash content, %	Mass fraction of humic substances, %		
				Total	HA	FA
Brown coal (Russia)	0	0	12.6 ± 0.6	29.3	16.9	12.4
	3	180	8.3 ± 0.4	34.4	19.3	15.1
	6	360	7.9 ± 0.4	33.4	18.2	15.2
	12	720	7.4 ± 0.4	35.8	20.5	15.3
Brown coal (Kazakhstan)	0	0	3.6 ± 0.2	29.6	13.4	16.2
	3	180	3.3 ± 0.2	32.2	15.9	16.3
	6	360	3.5 ± 0.2	40.8	16.6	24.2
	12	720	3.5 ± 0.2	38.9	15.3	23.6

The increase in the yield of humic substances and water-soluble salts will favorably affect the features of the potting soil because these components are necessary for plant growth and development [14, 15, 24].

Based on the obtained information, the requirements to the initial raw material were drawn up. Depending on its features, the optimal operating modes of the EHDE were selected.

The general technological scheme of brown coal grinding as a component of potting soils is presented in Figure 7. At the same time, as it was mentioned above, an organic component of substrates in enclosed systems can be used from plant residues, sewage sludge, food waste, etc.

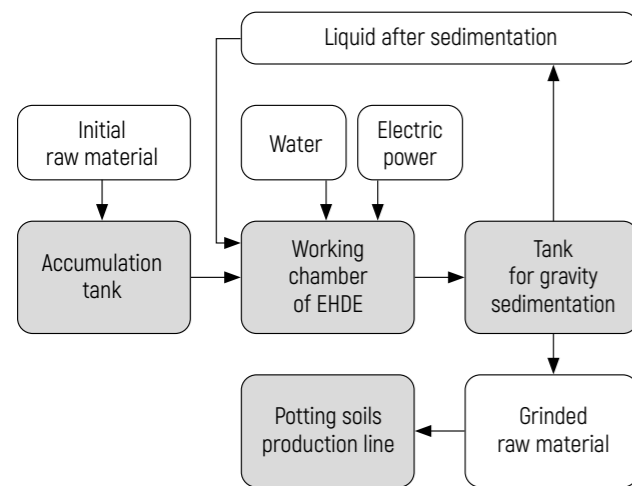

Figure 7 – Scheme of brown coal grinding as a component of potting soils

The initial material (brown coal or other organic raw material) is collected in an accumulation tank, then after adjusting/setting the necessary parameters of the EHDE is directed to the working chamber. A fresh portion of water and a part of the liquid after sedimentation of the grinded mass is also added here. During the operation of the unit, the fine fraction of the grinded mass enters through the upper pipe the tank for gravity sedimentation (as an option – sedimentation under the action of centrifugal force in the hydrocyclone), where part of the water is discharged into an intermediate tank, then pumped back to the EHDE for grinding. The sludge after sedimentation is pumped out and fed to the technological line of potting soils production. All parameters of the equipment operation are determined based on the line capacity and features of raw materials.

Application of the UniThorr EHDE for Water Disinfection

Water is one of the most important components of the human body, without which existence is impossible. That is why the issue of providing people with safe drinking water that meets the most stringent hygienic requirements and standards [3–5] is the key one in enclosed ecosystems, along with nutrition and respiration. Under such conditions, the need to create an efficient closed-loop system of water disposal, water treatment and subsequent supply of quality drinking water to the ECH inhabitants is acutely realized [6, 7].

Electrical cleaning methods seem to be the most promising. Their essence lies in the conversion of electrical energy into other types of energy affecting the object of treatment. A good alternative to traditional disinfection methods in the process of creating a closed-loop purification system will be the use of EHDE.

An electrohydraulic shock in water caused by electric impulses of short duration (a few microseconds) but high instantaneous power (50–1,000 MW) leads to the appearance of active free radicals, atomic oxygen and hydrogen, compounds of nitrogen and simple amino acids. The process is facilitated by air and gases dissolved in water. Microbial flora, primarily bacterial, is actively killed in this process, which is associated with ultrasonic, ultraviolet and X-ray radiation of the discharge channel plasma as well as with the powerful oxidizing effect of atomic oxygen [25].

When water is disinfected by an electrohydraulic shock, a complex of factors, depending on the microbe species/strain, leads to the death of microorganisms. The liquid treated in this way acquires bactericidal properties that are stable over time. Studies on the effect of electrohydraulic shock on various microorganisms, including the intestinal bacterium group, the main representative of which is *Escherichia coli* [18, 25], are described in [26, 27]. In view of the above, it can be concluded that the use of this method is relevant for water disinfection.

In the present work, the gram-positive spore-forming soil bacterium *Bacillus subtilis* (*B. subtilis*) strain G BKM B-911, or hay bacillus, taken from the own microorganism bank of the laboratory of the Biotechnology Department of Unitsky String Technologies Inc. was chosen as an object of study [3, 25].

The choice of the object of research is dictated by the fact that, on the one hand, this strain is an indicator test culture for determining the effectiveness of sterilization. On the other hand, spore-forming bacteria can remain dormant for a long time under unfavorable conditions, which allows them to survive and disperse more efficiently. Spores are characterized by a low level of metabolic activity, are distinguished by an unusually high heat resistance, preserving viability at boiling for several hours, as well as by an increased resistance to ultraviolet radiation and mechanical impact.

Aged 3–4-day-old cultures were used for the experiment, which were subjected to an electrohydraulic shock. Water sampling before and after the impact was performed by an aseptic method. Repetition rate of each sample was equal to three. Planting on the surface of dense agarized medium was carried out by the Koch method; the cultures

were incubated on nutrient agar and counting of the grown colonies was performed [28]. The degree of water disinfection was judged by the change in the number of colony-forming units (CFU), which was expressed as the total microbial count (TMC).

The obtained results showed that disinfection occurs quite intensively, and the rate of the process is proportional to the number of pulses causing electrohydraulic shocks. It was found that the residual value of TMC at the initial concentration of microorganisms 3×10^4 CFU/ml is less than 50 CFU/ml, which meets the requirements of SanPiN 10-124 [29] to the quality of drinking water by this indicator. The most intensive disinfection effect is observed at treatment time of up to 10 min, and during the initial 6–10 s of the EHDE operation up to 94 % of microorganisms are eliminated (Figure 8).

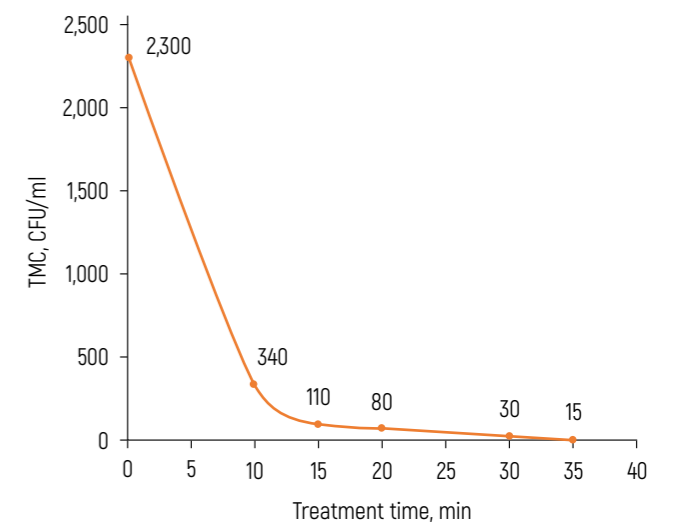

Figure 8 – Influence of treatment time on TMC at an initial microorganism concentration of 3×10^4 CFU/ml

This subject is researched and described in more detail in [25].

When arranging water disinfection in the ECH, the installation on the ISS is offered for consideration as an example of a really existing water purification system in space conditions. The technology including distillation and iodization [30] is implemented here, which needs to be improved and finalized. The recovery system provides clean water for astronauts by utilizing urine, condensate moisture in the living quarters appeared from crew sweat, breathing and hygiene as well as water from the air recovery system.

To regenerate water from atmospheric moisture condensate, a sorption-catalytic method is applied, followed by mineralization, conservation with silver and pasteurization of purified water. The urine treatment unit is designed to obtain 87 % of water from crew urine. Water is extracted by distillation with sorption-catalytic purification. The distillate is combined with condensate and processed using a water treatment unit that recovers 100 % of this liquid. As a result, the total water recovery is about 93.5 % [31]. Regeneration of sanitary-hygienic water is carried out by filtration with subsequent sorption additional cleaning.

Iodization as a disinfection method is suitable only for small-scale individual installations; it has a number of disadvantages, including changes in iodine concentration during operation, impossibility of accurate dosing into running water and lack of control of iodine concentration. Studies show that iodization is optimal against bacteria and viruses and not efficient enough against microbial toxins and phenolic compounds. Another limitation on the spread of this method is the appearance of a specific odor when iodine is dissolved in water.

Instead of iodization unit it is proposed to use the EHDE, the effectiveness of which has been confirmed experimentally. A short period of exposure corresponding to a sharp drop in the TMC value is considered economically advantageous. Thus, the proposed technology of water disinfection is reduced to its periodic stepwise electrohydraulic treatment in the device, the layout of which is shown in Figure 9. The total energy expenditure in this case does not exceed $0.5 \text{ kW} \cdot \text{h}/\text{m}^3$ and correlates with the literature data [13].

The EHDE for water purification is designed as a pipe with pairs of positive and negative electrodes embedded in bushings running through its walls. The positive electrodes must be insulated and the negative electrodes can be part of the pipe itself. Each pair of electrodes will be fed from an independent discharge circuit.

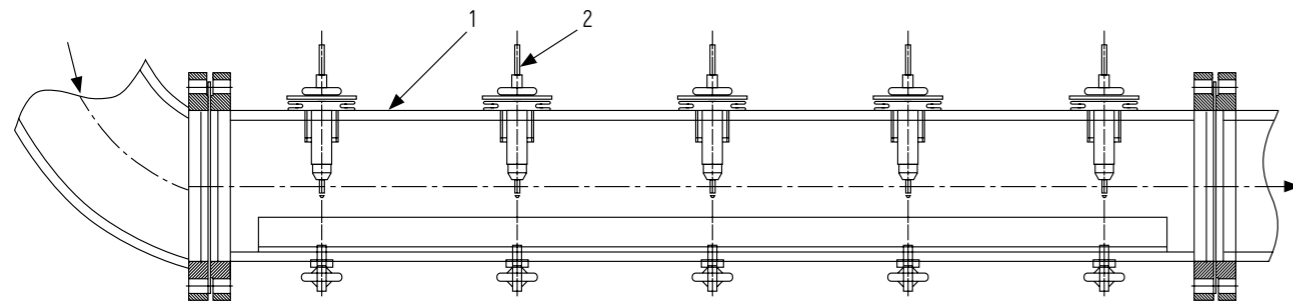

Figure 9 – Electrohydraulic device for water purification and disinfection: 1 – flow chamber; 2 – electrode

The principle of the EHDE operation for water purification is as follows. The disinfected liquid is uninterruptedly pumped into the EHDE and continues its movement inside the flow chamber made in the form of a pipe. Its body is equipped with several pairs of dischargers (the number is determined based on the capacity of the unit, the volume of liquid and the degree of its contamination), the electrodes of which are passed into the dielectric through the wall of the body. Electrohydraulic shocks disinfect the liquid in the flow at a certain time interval. The rate of disinfection is proportional to the energy of the pulses. The simplicity of the EHDE design facilitates the possibility of automation and adjustment of the purification processes as well as allows the creation of compact units of any capacity.

Application of the UniThorr EHDE in Fish Farming

When considering the issue of human habitation in space, special attention should be paid to development of aquaculture as a mandatory activity in enclosed space of the ECH. There are not many options to satisfy the need of its residents for food containing animal protein due to the complexity of animal breeding, limited areas and resources – water, food, oxygen. Fish is worth considering as a source of animal protein. In terms of nutritional qualities, it is not inferior to meat, and in terms of digestibility it even surpasses it. Thus, the protein content of fish is in the range of 13–23 %.

Today, the level of biotechnological capabilities of growing different aquaculture objects allows their production in closed-loop water supply units [32–35]. This provides significant water savings, which is a key point in the conditions of space with a sharp limitation of resources. Due to the circulation system, the unit is filled with water once and then only periodically recharged, and this requires only 4–6 % of water from the volume of the unit [36].

The classical diagram of a closed-loop water supply system for aquaculture growing in fish farms is presented in Figure 10. The required water quality in it is ensured by the functioning of biofilters. In general, the system includes mechanical, biological in biofilters and ultraviolet treatment.

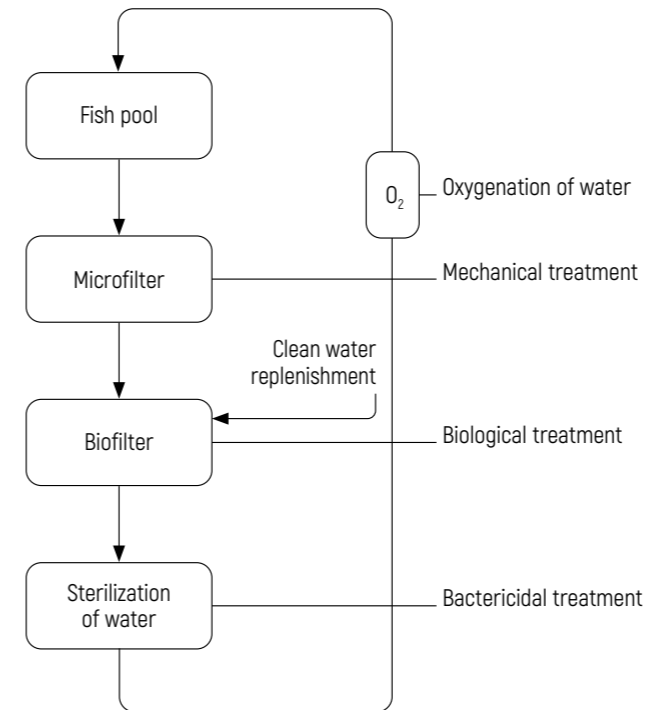

Figure 10 – Structure of the fishery recirculation system

At the first stage, the water collected from all fish pools in the storage tank is purified from mechanical suspension, i.e., from fish feces and feed residues. The equipment for this stage can be hydrocyclones, drum filters, etc. The accumulated sludge is removed and transferred to recycling. A hydrocyclone cleans the water from coarse suspended solids, while a drum filter cleans it from fine suspended solids.

At the second stage, water is purified in biofilters from dissolved impurities that cannot be captured by mechanical filters. Water from the drum filter is piped to the biofilter, which is a tank with diffusers at the bottom. These are supplied with air for constant aeration. The water tank also contains a plastic load for aeration. Bacteria grow on the load and process the dissolved substances. After the biofilter, the treated water is taken away by pumps. Specificity of biofilter functioning is conditioned by the use

of colonies of living organisms: it is required to observe a favorable temperature mode for them, to maintain a certain humidity, to ensure that the bacteria receive all the necessary nutrients for life and growth.

The third stage is disinfection of water with the help of ultraviolet light from pathogenic microorganisms and bacteria. Next, the water is fed to the oxygenator, where it is saturated with pure oxygen. This is an important purification stage: the water is mixed here with oxygen under pressure and then fed back into the pools.

The key problem of water pollution in fish farms is the active reproduction of microscopic algae, which brings about the appearance of toxic substances, rotting products, reduction of the amount of dissolved oxygen, thereby resulting in the death of fish if the treatment system is not operating well enough. The main representatives of microalgae that cause water blooms are cyanobacteria.

The peculiarity of fishery water treatment in closed-cycle installations is that it does not require achieving a complete bacterial semination of the circulating liquid. This is due to the fact that growing fish in a sterile environment reduces their immunity. The optimum level of water purification should be 70–75 %.

As described above, the UniThorr EHDE showed good results in disinfection of water from bacteria. In [37] there is information on the application of electrohydraulic shock for water treatment of fishery complexes, which gave the prerequisites for studying its effect on the quality of water containing microalgae. In addition, the replacement of biofilters at the EHDE will simplify the maintenance and control of the equipment due to the absence of the need to support specialized conditions during its operation. At the same time, no regeneration is required and no by-products of treatment are generated, while the occupied areas are smaller.

Associations of soil green microalgae *Chlamydomonadales*, *Chlorococcales*, *Ulothrichales*, *Desmidiiales*, taken from the own microorganism bank of the laboratory of the Biotechnology Department of Unitsky String Technologies Inc. were selected as objects of this study [3].

Electrohydraulic shock was applied to the tried-and-tested inoculum cultivated in liquid medium for 14 days. Water sampling was performed by the aseptic method. The repetition rate of each sample was three. Planting on the surface of a dense agarized medium was carried out by the Koch method, incubation was carried out on light racks under illumination for 12 h, then counting of the grown colonies on algae nutrient medium was performed. The cell growth time on the nutrient medium was 10–12 days.

Taking into account the data obtained, a definite regularity between the treatment time and the total cell count (TCC) of algae can be seen (Figure 11). Initially, during the first minute of the EHDE operation, there is a sharp drop in TCC from 2×10^4 to 2×10^2 CFU/ml. Then, the decrease in TCC value continues more gradually from 250 to 30 CFU/ml. After 5 min of treating water with microalgae, the dependence of TCC on exposure time reaches a plateau and changes weakly over the next 25 min. The residual concentration of microalgae after 30 min of the EHDE operation is 5 CFU/ml.

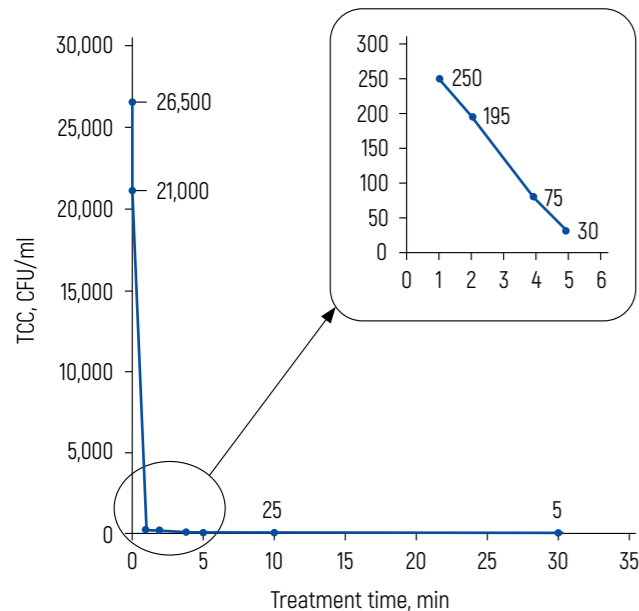

Figure 11 – The effect of treatment time on TCC of microalgae

The results of the conducted experiments show that the use of electrohydraulic shock allows to reduce biological contamination, not bringing water to a sterile state, but decreases bacterization of recycled water to a value that provides comfortable conditions for cultivation of farmed fish at different stages of growing.

The complex character of electrohydraulic shock is especially important in the purification of waters containing a wide range of microorganisms. In this regard lake water sampled in the Aquarelle EcoPark (Maryina Gorka, Belarus) was also studied. The artificial reservoir located there was chosen as a prototype of an enclosed aquatic ecosystem.

The data obtained (Figure 12) are identical to the results from the treatment of water contaminated with *B. subtilis* (Figure 8) and microalgae (Figure 11).

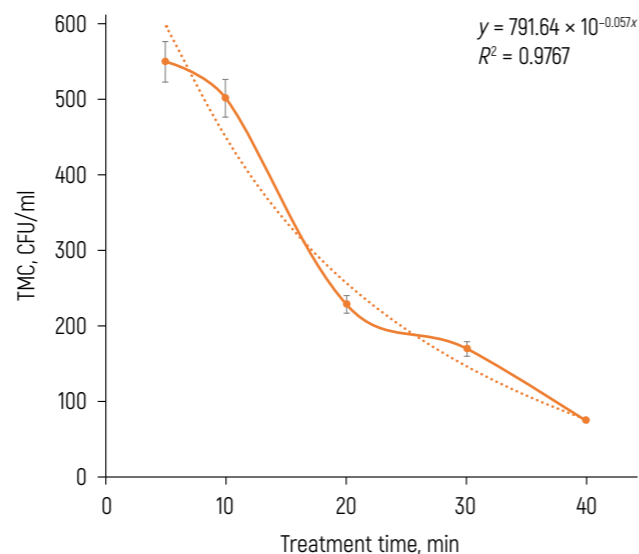

Figure 12 – The effect of treatment time on TMC of lake water

The residual TMC value after treatment at the UniThorr EHDE is higher than that for water contaminated with bacteria and algae and amounted to 75 CFU/ml. This is due to the higher initial TMC value.

Figure 13 shows the modernized general diagram of water purification with the application of electrohydraulic shock in closed-loop water supply installations at fish complexes.

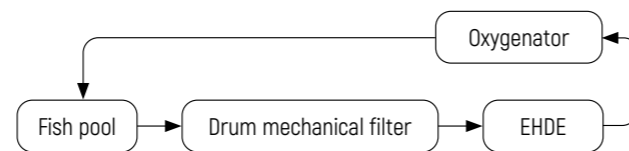

Figure 13 – Water purification diagram for a fish farming

Operating concept of the system is that the water is initially purified from coarse and fine impurities, then supplied under gravity to an electrohydraulic shock treatment unit in a continuous mode (this principle is described above for the water disinfection system). After treatment, the water undergoes disinfection quality control and, if the required standards are met, is fed to the next stage of preparation before entering the pool with aquaculture. If the water quality does not meet any of the indicators, it is returned to the EHDE inlet for re-treatment. The operating parameters of the equipment are selected individually for each aquaculture complex.

Conclusion

The present article reflects the problems of limited resources in the conditions of human habitation in enclosed ecosystems in space. Several variants of the EHDE application have been considered and tested, taking into account their further use in the ISN "Orbit", and the advantages of the electrohydraulic effect have been shown. The proposed solutions are supported by studies conducted in 2020–2023 at the experimental UniThorr EHDE designed by the employees of Unitsky String Technologies Inc.

The feasibility of utilizing the unit has been researched:

- for grinding brown coal as a potting soils component for the purpose of cultivating plant food under cosmic conditions;
- for disinfection of drinking and waste water and purification of water intended for fish farming in closed-loop systems (on the example of water artificially contaminated with *B. subtilis* bacterium strain and soil green microalgae *Chlamydomonadales*, *Chlorococcales*, *Ulothrichales*, *Desmidiiales* as well as native lake water).

The obtained results confirm high efficiency of this method and, accordingly, the feasibility of using the EHDE in the schemes of closed-loop cycle of water consumption and water disposal, waste utilization, production of potting soils for plant cultivation in residential clusters of the ISN "Orbit".

Further research will be aimed at increasing the efficiency of the EHDE operation and improving its structural elements as well as at solving the issue of creating a full cycle of water consumption and water disposal under the ECH conditions.

References

1. Unitsky, A.E. *Strunnyye transportnyye sistemy: na Zemle i v Kosmose [String Transport Systems: On Earth and in Space]* / A.E. Unitsky. – Gomel: Infotribo, 1995. – 337 p.: ill.
2. Unitsky, A. *String Transport Systems: On Earth and in Space* / A. Unitsky. – Silakrogs: PNB Print, 2019. – 560 p.
3. Unitsky, A. *Soil and Soil Microorganisms in EcoCosmo-House Biosphere* / A. Unitsky, E. Solovyova, N. Zyl // *Non-Rocket Space Industrialization: Problems, Ideas, Projects: Collection of Articles of the II International Scientific and Technical Conference, Maryina Gorka, Jun. 21, 2019* / Astroengineering Technologies LLC; ed. A. Unitsky. – Minsk: Paradox, 2019. – P. 179–183.
4. Unitsky, A. *Creating of a Mathematical Model of the General Planetary Vehicle: Accelerating Flywheels, Passing the Atmosphere, Going into Orbit* / A. Unitsky, R. Sharshov, A. Abakumov // *Non-Rocket Space Industrialization: Problems, Ideas, Projects: Collection of Articles of the II International Scientific and Technical Conference, Maryina Gorka, Jun. 21, 2019* / Astroengineering Technologies LLC; ed. A. Unitsky. – Minsk: Paradox, 2019. – P. 77–83.
5. *Bezraketnaya industrializatsiya blizhnego kosmosa: problema, idei, proyekty [Non-Rocket Near Space Industrialization: Problems, Ideas, Projects]: Collection of Articles of the III International Scientific and Technical Conference, Maryina Gorka, Sep. 12, 2020* / Astroengineering Technologies LLC, Unitsky String Technologies Inc.; ed. A.E. Unitsky. – Minsk: StroyMediaProyekt, 2021. – 516 p.
6. Unitsky, A. *The Engineer: Autobiography* / Anatoli Unitsky. – Minsk, 2020. – 400 p.: ill.
7. Unitsky, A. *System Foundations of Non-Rocket Near Space Industrialization: Problems, Ideas, Projects* / ed. A. Unitsky. – Minsk: Gradient, 2021. – 568 p.
8. *Sovremennyye sistemy zhizneobespecheniya korablya [Modern Systems of Ship's Life Support] [Electronic resource]*. – Mode of access: <https://sovkos.ru/cosmicheskie-apparaty/sovremennyye-sistemy-zhizneobespecheniya-korablya.html>. – Date of access: 11.06.2023.
9. *Pod kupolom: istoriya razvitiya zamknutykh ekosistem – ot razrabotok SSSR do sovremennogo Kitaya [Under the Dome: History of Enclosed Ecosystems – From the Soviet Union's Developments to Modern China] [Electronic resource]*. – Mode of access: <https://vc.ru/future/50469-pod-kupolom-istoriya-razvitiya-zamknutykh-ekosistem-ot-razrabotok-sssr-do-sovremennogo-kitaya>. – Date of access: 10.06.2023.
10. *Rasteniya v kosmose. Chto i kak vyrashchivayut na MKS [Plants in Space. What and How They Grow on the ISS] [Electronic resource]*. – Mode of access: <https://aogarden.ru/news/rasteniya-v-kosmose-cto-vyrashchivayut-na-mks/>. – Date of access: 11.06.2023.
11. *Istoriya iskusstvennykh biosfer: zachem nuzhna kosmicheskaya teplitsa [History of Artificial Biospheres: Why a Cosmic Greenhouse Is Needed] [Electronic resource]*. – Mode of access: <https://theoryandpractice.ru/posts/7613-biosphere>. – Date of access: 15.06.2023.
12. *Kosmicheskaya solnechnaya energetika i perspektivy razvitiya alternativnoy energetiki na orbite [Space Solar Power Industry and Prospects for the Development*

- of an Alternative Power Industry in Orbit] [Electronic resource]. – Mode of access: <https://maxpolyakov.com/ru/kosmicheskaya-solnechnaya-energetika-kak-vid-alternativnogo-istochnika-energii/>. – Date of access: 15.06.2023.
13. Yutkin, L.A. *Elektrogidravlicheskiy effekt i yego primeneniye v promyshlennosti* [Electrohydraulic Effect and Its Application in Industry] / L.A. Yutkin. – Leningrad: Mashinostroyeniye, 1986. – 253 p.
 14. *Prospective Compositions and Methods for the Production of Light Potting Soils for the EcoCosmoHouse* / A. Unitsky [et al.] // *Non-Rocket Near Space Industrialization: Problems, Ideas, Projects: Collection of Articles of the V International Scientific and Technical Conference, Maryina Gorka, Sep. 23–24, 2022* / Astroengineering Technologies LLC, Unitsky String Technologies Inc.; ed. A. Unitsky. – Minsk: StroyMediaProject, 2023. – P. 248–259.
 15. *Razrabotka sostava pochvogrunta dlya zamknutoy ekosistemy v kosmicheskom prostranstve* [Developing Potting Soil Composition for Enclosed Ecosystem in Outer Space] / A.E. Unitsky [et al.] // *Bezraketnaya industrializatsiya blizhnego kosmosa: problemy, idei, proyekty: Collection of Articles of the III International Scientific and Technical Conference, Maryina Gorka, Sep. 12, 2020* / Astroengineering Technologies LLC, Unitsky String Technologies Inc.; ed. A.E. Unitsky. – Minsk: StroyMediaProyekt, 2021. – P. 412–423.
 16. Unitsky, A. *The Use of Roofs of Multi-Purpose Buildings for Allocation of Greenhouses: Specifics and Optimal Solutions* / A. Unitsky, M. Davydik, N. Zyl // *Non-Rocket Near Space Industrialization: Problems, Ideas, Projects: Collection of Articles of the V International Scientific and Technical Conference, Maryina Gorka, Sep. 23–24, 2022* / Astroengineering Technologies LLC, Unitsky String Technologies Inc.; ed. A. Unitsky. – Minsk: StroyMediaProject, 2023. – P. 136–151.
 17. Golovko, A.N. *Perspektivy ispol'zovaniya elektricheskikh metodov dlya ochistki zhidkikh organicheskikh otkhodov zhitovnovodstva* [Prospects of Using Electrical Methods for Cleaning Liquid Organic Wastes of Livestock Farming] / A.N. Golovko, A.M. Bondarenko // *Vestnik agrarnoy nauki Dona*. – 2018. – No. 1 (41). – P. 52–57.
 18. *Escherichia Coli Disinfection by Electrohydraulic Discharges* / W.K. Ching [et al.] // *Environmental Science & Technology*. – 2021. – Vol. 35 (20). – P. 4139–4144.
 19. *Rukovodstvo po akvakul'ture v ustanovkakh zamknutogo vodosnabzheniya* [Guideline for Aquaculture in Closed-Loop Water Supply Installations] [Electronic resource]. – Mode of access: <http://aquacultura.org/upload/files/pdf/library-5.pdf>. – Date of access: 15.06.2023.
 20. *Ekologicheskiy spravochnik dlya rybovodnoy promyshlennosti Severo-Zapada Rossii* [Environmental Manual for the Fish Farming Industry of North-West Russia] [Electronic resource]. – Mode of access: <https://barenzevo.arktifiksh.com/akvakultura-barentseva-morya/ekologicheskij/6-2-tehnologicheskie-metody>. – Date of access: 15.06.2023.
 21. *Meliorant-pochvouluchshitel "Gumus UniTerra". Tekhnicheskiye usloviya* [Ameliorant-Soil Improver "Humus UniTerra". Technical Specifications]: TU BY 691935133.002-2019. – Introduced 19.03.2019. – Minsk: Gosstandart: Belorusskiy gosudarstvennyy institut standartizatsii i sertifikatsii, 2019. – 12 p.
 22. Musenko, A.A. *Provedeniye issledovaniy po vliyaniyu EG obrabotannoy vody na rost i razvitiye rasteniy* [Carrying Out the Research on the Influence of Electrohydraulic Treated Water on the Growth of Plants] / A.A. Musenko, A.A. Belov // *Vestnik agrarnoy nauki Dona*. – 2020. – No. 3 (51). – P. 54–60.
 23. *Toplivo tvordoye. Sitovyy metod opredeleniya granulometricheskogo sostava* [Solid Fuel. Sieve Method for Determination of Granulometric Composition]: GOST 2093-82 [Electronic resource]. – Mode of access: <https://internet-law.ru/gosts/gost/29876/>. – Date of access: 15.06.2023.
 24. *Fertility and Physico-Chemical Indicators of Light "Space" Potting Soils for EcoCosmoHouse* / A. Unitsky [et al.] // *Non-Rocket Near Space Industrialization: Problems, Ideas, Projects: Collection of Articles of the IV International Scientific and Technical Conference, Maryina Gorka, Sep. 18, 2021* / Astroengineering Technologies LLC, Unitsky String Technologies Inc.; ed. A. Unitsky. – Minsk: StroyMediaProject, 2022. – P. 309–326.
 25. *The Use of the Electrohydraulic Effect for the Disinfection of Wastewater in the Conditions of Human Habitation in Space* / A. Unitsky [et al.] // *Non-Rocket Near Space Industrialization: Problems, Ideas, Projects: Collection of Articles of the V International Scientific and Technical Conference, Maryina Gorka, Sep. 23–24, 2022* / Astroengineering Technologies LLC, Unitsky String Technologies Inc.; ed. A. Unitsky. – Minsk: StroyMediaProject, 2023. – P. 152–161.
 26. Belov, A.A. *Razrabotka laboratornoy elektrogidravlicheskoj ustanovki dlya obezrazhivaniya vody* [Design of a Laboratory Electro-Hydraulic Installation for Water Disinfection] / A.A. Belov // *Elektrotekhnologii i elektrooborudovaniye v APK*. – 2020. – Vol. 67, No. 2 (39). – P. 3–7.
 27. *Provedeniye eksperimenta po obezrazhivaniyu vody obrabotkoy vysokovol'tnymi razryadami* [Conducting the Experiment on Water Disinfection by Treating with High-Voltage Discharges] / A.A. Belov [et al.] // *Vestnik NGIEI*. – 2019. – No. 8 (99). – P. 34–43.
 28. Kontsevaya, I.I. *Mikrobiologiya: fiziologicheskiye gruppy bakteriy* [Microbiology: Physiological Groups of Bacteria]: Practical Manual / I.I. Kontsevaya. – Chernigov: Desna Poligraf, 2017. – 40 p.
 29. *Pit'yevaya voda. Gigiyenicheskiye trebovaniya k kachestvu vody tsentralizovannykh sistem pit'yevogo vodosnabzheniya. Kontrol' kachestva* [Drinking Water. Hygienic Requirements for Water Quality of Centralized Drinking Water Supply Systems. Quality Control]: SanPiN 10-124 RB 99. – Introduced 01.01.2000. – Minsk: Gosstandart: Belorusskiy gosudarstvennyy institut standartizatsii i sertifikatsii, 2000. – 112 p.
 30. Dolina, L.F. *Ochistka stochnykh vod v usloviyakh kosmosa* [Wastewater Purification in Space Conditions] / L.F. Dolina, Yu.A. Zhdan, D.A. Dolina // *Nauka ta progres transportu*. – 2020. – No. 2 (86). – P. 7–15.
 31. *Novaya sistema ochistki vody budet rabotat' ne tol'ko na MKS, no i na Lune* [New Water Purification System Will Work Not Only at the ISS But Also on the Moon] [Electronic resource]. – Mode of access: https://hightech.fm/2021/03/02/new-brine-processor?is_ajax=1. – Date of access: 15.06.2023.
 32. *Elements of Circular Technologies in Aquaculture on the Waters of Energy Facilities* [Electronic resource] / M. Kalaida [et al.]. – Mode of access: https://www.researchgate.net/publication/353241991_Elements_of_circular_technologies_in_aquaculture_on_the_waters_of_energy_facilities. – Date of access: 15.06.2023.
 33. *Sovershenstvovaniye biotekhnologii vyrashchivaniya somov* [Siluroidea] – *Silurus glanis L., Clarias gariepinus, Pangasius sutchi na vodakh ob'ektov energetiki* [Improvement of Biotechnology of Growing Somas [Siluroidea] – *Silurus glanis L., Clarias gariepinus, Pangasius sutchi in the Water of Power Objects*] / M.L. Kalayda [et al.] // *Aktual'nyye voprosy sel'skokhozyaystvennoy biologii*. – 2021. – No. 2 (20). – P. 39–51.
 34. Piganov, Ye.S. *Iskusstvennoye vosproizvodstvo afrikanskogo klariyevogo soma na baze kafedry "Vodnyye bioresursy i akvakul'tura"* [Artificial Reproduction of African Sharptooth Catfish at the Department "Aquatic Bioresources and Aquaculture"] [Electronic resource] / Ye.S. Piganov, M.F. Khamitova, M.L. Kalayda. – Mode of access: https://www.elibrary.ru/download/elibrary_43986244_86910836.pdf. – Date of access: 15.06.2023.
 35. *Voda i zhizn' na Marse* [Water and Life on Mars] [Electronic resource]. – Mode of access: https://elibrary.ru/download/elibrary_23244541_92556435.pdf. – Date of access: 14.06.2023.
 36. Ibragimova, G.D. *Akvakul'tura kak perspektivnaya kosmicheskaya biotekhnologiya* [Aquaculture as a Promising Space Biotechnology] [Electronic resource] / G.D. Ibragimova // *Tinchurinskiye chteniya – 2022 "Energetika i tsifrovaya transformatsiya": International Youth Scientific Conference, Kazan, Apr. 27–29, 2022*. – Vol. 2. – Mode of access: https://www.elibrary.ru/download/elibrary_49190352_15822427.pdf. – Date of access: 11.06.2023.
 37. *Obezrazhivaniye vod v ustanovkakh zamknutogo vodosnabzheniya* [Water Disinfection in Closed-Loop Water Supply Installations] [Electronic resource]. – Mode of access: <https://xn--80aaheadwcbnhcvmjd3ae6a0t.xn--p1ai/tech/voda/obez>. – Date of access: 12.06.2023.

Technological Systems for Cultivating Plants in the EcoCosmoHouse

A. Unitsky^{1,2}
Dr. of Philosophy
in Information Technologies
(Transport)

N. Zyl²

D. Konyok²

M. Parfenchik²

¹ Astroengineering Technologies LLC,
Minsk, Belarus

² Unitsky String Technologies Inc.,
Minsk, Belarus



Technologies for cultivating plants on an orbital station, applicable in creating an enclosed ecosystem of the EcoCosmoHouse (ECH), are considered. Existing units and substrates used for growing crops in near-Earth orbit are described as well as methods for providing nutrient solutions and fertile soil. Promising areas for the manufacturing technology development for plant products on space stations and ships intended for long-term human stay are proposed. The novelty of the study lies in the fact that the ECH identifies zones of recreational and intensive plant cultivation. For the recreational zone, it is planned to choose a highly effective method which involves the application of light potting soils developed on the basis of uTerra biohumus and allowing to create a natural environment at the orbital station. For intensive cultivation of green and vegetable crops as well as for breeding plants to obtain secondary metabolites, it is proposed to use foamed nutrient solutions prepared from uTerra complex organic fertilizer. In addition, the issue of protecting plants from diseases and pests is analyzed.

Keywords:

EcoCosmoHouse (ECH), enclosed ecosystem, growing plants on space stations, humus, humusponics, light potting soil, plant growing, soil, soil microorganisms.

Introduction

At present, the space industry is actively developing. The growth of the world space market is about 9% per year [1]. A significant amount of modern research is focused on the creation of space stations that assume a long stay of a human being with a minimal supply of foodstuffs from the outside [2]. As a rule, such stations are made in the form of residential complexes, where it is possible to cultivate plant products by means of aeroponics and hydroponics.

One of the main tasks of developing this direction is to design a large-volume space station that will provide its residents not only with fresh plant products but also with other foodstuffs and components necessary for psychological comfort during work and recreation. Such a space station is the EcoCosmoHouse (ECH) [3].

The ECH is an infrastructural solution for a long-term and comfortable accommodation of residents in near-Earth orbit. It is planned to create conditions for any long stay of people at the ECH, who will be provided with everything they need for a full-quality life: organic products for a healthy balanced diet, clean air, artificial gravity, sufficient area for work, recreation and physical activity, safety of living and a favorable subtropical microclimate.

Providing humans with a nutritious organic diet is one of the key components of the biotechnologies developed for the ECH functioning. At the same time, plant food is needed not only for humans but also for animals bred for foodstuff manufacturing.

While striving for a minimal but sufficient volume, all production areas in the ECH, including those intended for plant cultivation, should be as compact as possible but without compromising the quality of life. Meanwhile, it is necessary to take into account not only the provision of the ECH residents with healthy food needed for the full functioning of the human body but also another aspect. When staying in an isolated space for a long time, the issues of psychological health come to the forefront [4]. Consequently, in addition to a high-quality and cost-effective production of plant foodstuffs in enclosed ecosystems, it is necessary to provide ways of spending leisure time. According to astronauts' feedback, one of the fascinating variants of this activity is caring for plants [5].

Methods of Plant Cultivation on Space Stations

Food production systems in space represent the latest achievements of science in the field of agriculture, biology and robotics.

Such devices of the Oasis-1 series (Figure 1) were first commissioned in 1971 at the Salyut-1 orbital station, where cosmonauts conducted experiments on growing flax, leek, common onion and Chinese cabbage [6].

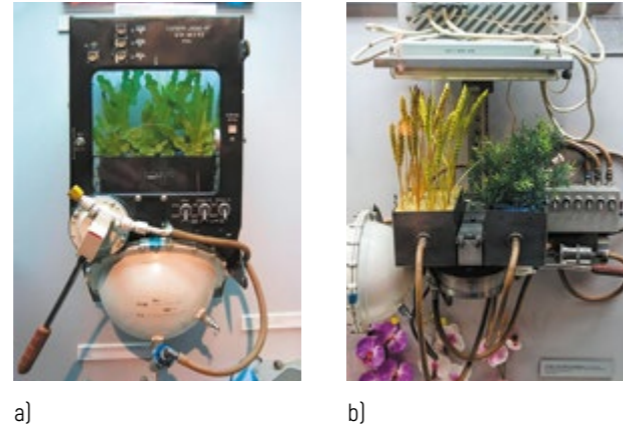

Figure 1 – Oasis unit: a – Oasis-1M; b – Oasis-1A [6]

In 2014, the Veggie system (Figure 2) was launched, which was designed not only for experiments with plants under microgravity conditions but also for food production [7].

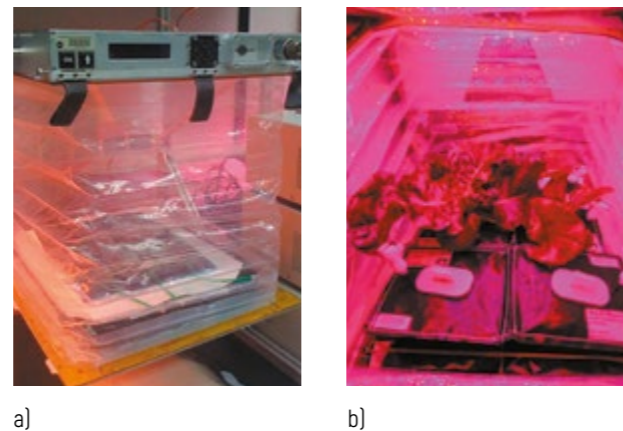

Figure 2 – Veggie vegetable growing system: a – terrestrial prototype before the launch [8]; b – Veg-03 version in operation [9]

This type of apparatus is produced prefabricated for easy transportation. For example, when in the assembled state, the Veggie structure makes up 10% of the volume in operational condition.

Space micro-greenhouses have the following basic components: body, irrigation and plant nutrition system, lighting system, capillary mat or substrate for plants. The occupied area in modern units is about 0.2 m².

A specialized LED panel with red, blue and green LEDs is used as illumination, which is able to provide plants with more than 300 μmol/(m²·s) of illumination. The illuminance values in different systems are given in Table 1 [7].

Table 1 – Lighting systems in the units designed for plant cultivation at space stations

Unit	Type of lamps	Light intensity, μmol/(m ² ·s)	Additional information
Oasis-1	Fluorescent lamp	50–68	–
Oasis-1M	Fluorescent lamp	50–68	–
Oasis-1AM	Fluorescent lamp	50–68	–
Oasis-1A	Fluorescent lamp	170–350	Separation of lamps and germination module allows to adjust the distance between lamps and leaves
Vazon	Without additional lighting	Without additional lighting	Cabin light was used to illuminate the plants
Malachite	Presumably a fluorescent lamp	No information	–
Biogravistat/Magnetobiostat	Without additional lighting	Without additional lighting	Closed compartment for studying germination and early root development
Svetoblock	Fluorescent lamp	No information	–
Phyton	No information	No information	At first the cabin light was used, later a separate lighting system was added
Svet	Fluorescent lamp	≈216 (12,000 lx)	LED lamp (red, blue, green)
Plant Growth Unit	Fluorescent lamp	30–75	–
Plant Growth Facility	Fluorescent lamp	>220	–
Astroculture	LED lamps (red, blue)	Red: 0–450 Blue: 0–50	–
Plant Generic Bioprocessing Apparatus	Fluorescent lamp	>350	–
Advanced Astroculture	LED lamps (red, blue)	Red: 0–550 Blue: 0–70	–
Biomass Production System	Fluorescent lamp	50–350	Adjustable in increments of 5 μmol/(m ² ·s)
Lada	Fluorescent lamp	250	–
European Modular Cultivation System	LED lamps (infrared, white)	No information	–
Plant Experiment Unit	LED lamps (red, blue)	110	Ratio of red and blue LEDs is 3 : 1
Advanced Biological Research System	LED lamps (red, blue, green, white)	300	–
Veggie	LED lamps (red, blue, green)	>300	–

The data in Table 1 show: just like in terrestrial agriculture, the use of LED sources with a combination of red, blue and green illumination is most justified due to their high energy efficiency (about 30 $\mu\text{mol}/(\text{m}^2 \cdot \text{s})$ at a distance of 20 cm per 1 W of power consumption), long service life (50,000 h and more), ease of operation [10].

The unit body protects the plants from unfavorable environment and maintains high humidity in the cabin. The folding design allows adjusting the distance between the lighting system and the capillary mat or substrate serving for germination of the root system and delivery of nutrients. Thus, taking care of plants, supplying them with water and nutrient solution does not take much time for astronauts [11, 12].

The crops obtained from these systems are used as a supplementary food for the crew of the International Space Station (ISS). During the experiments at the Veggie units, the grown products are treated in accordance with the requirements of NASA's microbiological standards, which are responsible for food quality. As a result of the sanitization, the number of microorganisms is reduced by 99 %. However, such disinfection would be unnecessary in enclosed ecosystems on a larger scale, as it is difficult to imagine a complete sterilization of products in mass manufacture. In addition, microorganisms are an important part of the biosphere and are essential to build an enclosed ecosystem.

In February 2023, the first crops of tomatoes were obtained on the ISS using the Veg-05 unit of the Veggie series, designed for the production of vegetables (Figure 3). Prior to this, a crop of peppers was grown at the Plant Habitat-04 unit in 2021 (Figure 4).



Figure 3 – Dwarf tomatoes grown at the ISS using the VEG-05 unit [13]



Figure 4 – Crop of peppers obtained at the ISS using the Plant Habitat-04 unit [5]

The modern agriculture arranged on orbital piloted stations already makes it possible to provide astronauts with a small amount of fresh greens. In order to obtain a significant volume of plant products, which is needed at least 400 g per day per person, it is necessary to develop the technology of plant cultivation in such ecosystems as the ECH, which implies circulation of substances and supplying of the residents with all required food.

Promising Directions of Developing the Technology of Growing Plant Products in Space

Allocation of Recreational Zone and Zone for Intensive Growing of Plant Products

The recreational zone involves the cultivation of crops that are optimally suited for greenhouse-type structures. Using technologies that allow, on the one hand, to maintain a comfortable and aesthetically attractive environment for humans and, on the other hand, to obtain valuable nutritious and medicinal materials [14], it is possible to plant trees, shrubs, some vegetable and fruit crops, medicinal herbs in the ECH on open areas intended for recreation. It is known that caring for plants can relieve stress and provide psychological comfort.

To create green areas in the ECH, it is assumed to use a substrate specially developed for such structures and having the following features: durability, low density, ability to retain moisture, the content of macro- and microelements necessary for plant nutrition, the availability of conditions favorable for the life of small soil animals and microorganisms.

Obtaining plant products in specially equipped units can be referred to intensive manufacturing, which involves the cultivation of large volumes of green crops, low-growing vegetable, berry, fruit, aromatic and medicinal plants.

Some green and vegetable crops are planned to be planted in specially equipped vegetariums built by analogy with earthly automated complexes used in traditional horticulture. Examples of such devices are the Veg-04, Lada and Lada-2 micro-greenhouses, where experiments on growing soybeans, barley, duckweed, peas, potatoes and dwarf wheat are conducted.

Maintaining a favorable temperature, optimal humidity and increased concentration of carbon dioxide helps to raise the rate of harvesting and improve its quality. It is proposed to separate biotechnological complexes out of the main volume of the ECH premises, where a controlled microclimate and the necessary composition of the gaseous environment will be created. It is possible to maintain carbon dioxide concentration in the range of 2,000–4,000 ppm for plants in the intensive production zone and 300–1,000 ppm in the recreational zone by means of absorption or gas filters. On the one hand, this approach will provide more efficient photosynthesis processes (by 15–20 %) and lower rates of intensive production, on the other hand, the gaseous environment of the main ECH volume will be optimal for humans, animals and plants.

The cultivation of algae and microalgae in bioreactors is a promising direction for biomanufacturing of plant products in enclosed ecosystems. In this case, it is proposed to emphasize compact cultivation of red seaweeds and laminaria.

Microalgae can be used as a source of valuable proteins, vitamins and other micronutrients. Despite the fact that most of them have a specific taste and odor, according to some data [15], 3–4 g of chlorella biomass per day (300–400 g of one percent suspension) is sufficient for humans. Thus, chlorella and other microalgae can be applied as a biologically active additive to the diet focused on antioxidant and immunostimulating effects [16].

Humusoponics: Use of Liquid Humus Containing Microbiota Instead of Pure Hydroponics

When selecting materials to be sent to a space station, special attention is paid to their microbiological purity. The level of complexity in meeting such high requirements will be proportional to the size of enclosed ecosystems to be created.

Table 2 provides a description of the artificial and natural materials that were used in the space vegetariums.

Table 2 – Nutrient delivery systems used in plant cultivation units at space stations [7, 17]

Unit	Method of plant nutrition
1	2
Oasis-1	Ion exchange resin
Oasis-1M	Fibrous ion exchange resin
Oasis-1AM	Fabric ion exchange medium
Oasis-1A	Ion exchange resin; root zone aeration system
Vazon	Fabric bag filled with ion exchange resin
Malachite	Ion exchange resin
Biogravistat/Magnetobiostat	Various materials depending on the type of experiment
Svetoblock	Nutrient medium based on agar (other media were used later)
Phyton	1.5 % agarized nutrient medium
Svet	Zeolite (1–2 mm particle size) with mineral fertilizers of prolonged action; nutrient solution supply system
Plant Growth Unit	Mineral base of different composition
Plant Growth Facility	Mineral base of different composition

End of Table 2

1	2
Astroculture	Porous tubes in mineral matrix for nutrient solution supply
Plant Generic Bioprocessing Apparatus	Agar, soil or nutrient substrate in gas-permeable polypropylene bags that can be connected to the water pipeline
Advanced Astroculture	Porous tubes in mineral matrix for nutrient solution supply
Biomass Production System	Porous tubes in mineral matrix for nutrient solution supply
Lada	Zeolite (1–2 mm particle size) with mineral fertilizers of prolonged action; nutrient solution supply system
European Modular Cultivation System	Reservoir with water designed to deliver nutrients
Plant Experiment Unit	Mineral wool; integrated pipe system for supplying nutrient solution
Chinese Space Greenhouse	Vermiculite with prolonged-acting mineral fertilizers
Advanced Biological Research System	Granulated substrate with peat mixture and prolonged-acting mineral fertilizers and/or supply of nutrients in the form of aerosol
Veggie	Granulated substrate with peat mixture and prolonged-acting mineral fertilizers; manual supply of water and nutrients

Thus, the first space units (1970–1980) designed for plant cultivation had utilized substrates (ion exchange resins and agarized media) that were more difficult to manufacture than those, which are used today. This difference can be explained by the desire to obtain a homogeneous substrate characterized by fully controlled parameters. Over time, such compositions were abandoned and the analogs of terrestrial complex potting soils based on mineral fillers were exploited.

In most cases, neutral materials (natural or artificial) that do not contain nutrients are applied, and a mixture of mineral components is supplied as a nutrient solution. Similar systems are used in the cultivation of plants on an industrial scale. The advantages of this technology include stability of operation of such complexes and high yields; however, the quality and taste of fruits becomes worse and ability of plants to resist pests and diseases decreases, since crops do not receive sufficient micro-, ultramicroelements and biologically active substances present in the soil as a result of activity of agronomically valuable microorganisms. Plants also create symbiosis with microorganisms and build complex systems of interaction [18]. In the human intestine alone, the volume of bacterial genetic information is 100 times larger than his own [19]. When using uTerra organic plant fertilizer, created by Unitsky String Technologies Inc. together with the Unitsky's Farm Enterprise [20], it is possible to implement the humusponics – a technology of biomanufacturing

of plant products, where humates as well as agronomically valuable soil microorganisms, which play an important role in the biosphere circulation, will be applied.

Application of Foamed Nutrient Solutions

Both in conditions of artificial gravity and weightlessness, it is proposed to cultivate plants with the help of foamed organic nutrient solutions containing the whole complex of macro-, micro- and ultramicroelements made on the basis of uTerra complex organic fertilizer. The use of foam will allow to effectively supply greenery with nutrients, reduce the probability of root overdrying, ensure complete wetting of the root system with nutrient solutions. The equipment for the production of organic foam substrates, which is one of the variants of implementing humusponics technology, can be insensitive to mechanical contamination and clogging of nozzles, tubes and filters with biofilms, because in such a design there are no nozzles spraying nutrient solutions and filters for their fine cleaning. The nutrient solution may have mechanical inclusions, which are pulverized when foam is created.

At present, there are methods of plant breeding using hydroponic technologies, which include nozzles that create foam. The advantage of such systems compared to classical hydroponics is that the foam hitting the roots is not retained

by the outer layer but penetrates deeper [21]. Among the disadvantages, a more complex composition and higher requirements for nozzles can be mentioned. When obtaining foam by other methods, i.e., not by spraying from nozzles but, for example, by mixing with air by means of a rotating working body, it is possible to get rid of this disadvantage.

Application of Light Potting Soils Developed on the Basis of Perlite

The choice of nutrient mixture, in which it is planned to breed plants in the ECH recreational zone, largely determines not only the quality of plant products obtained but also the stability of the entire ecosystem. It is economically reasonable to use a substrate with a minimum mass, which will fulfill all the functions of terrestrial soil, i.e., contain the necessary number and variety of nutritional elements and microorganisms, and small soil animals should also develop in it.

Light potting soils are a relatively new type of substrates utilized in modern agriculture due to a number of advantages, including low specific weight, high aeration of the root system, high moisture capacity, ease of use, relatively low cost. Light potting soils consist of:

- light mineral fillers;
- mineral sources of macro-, micro- and ultramicroelements;
- humus;
- organic part, which includes communities of thousands of species of agronomically valuable microorganisms.

Figure 5 shows variants of light potting soils researched by Unitsky String Technologies Inc., which have uTerra biohumus concentration from 2.5 to 15 %.



Figure 5 – Experiment to determine the optimal concentration of uTerra biohumus in a light potting soil developed on the basis of perlite

This experiment is still ongoing, and the preliminary conclusion can be done that, when growing lettuce, the optimum concentration of uTerra biohumus is 7.5 to 12.5 %, which is used together with uTerra liquid fertilizer. Further research is also planned to analyze physiological indices, aboveground and belowground biomass and quality of plant produce.

Until now, agricultural, ornamental and medicinal crops have been mainly cultivated in soil or substrates specially selected by their composition [22]. In terms of the number of mobile forms of elements required for plant nutrition, light potting soils are not inferior to their denser analogs: they have controlled indicators of nutritional content and can be used for growing vegetables, fruits and medicinal herbs, like substrates created on the basis of zeolite that were applied in experiments with the Svet unit. The disadvantages of light potting soils include the need for careful selection of composition, control of its condition, a greater cost than that of potting soils obtained only from natural materials and not undergoing additional treatment.

For the ECH, light potting soils should serve as a base on which it is planned to grow a wide range of crops, where people and animals will move and the process of organic waste treatment by agronomically valuable soil microorganisms will take place. In the study focused on light potting soils [23], the issue of optimal arrangement of plant products cultivation on the ECH territory is solved.

Biological and Physical Methods of Plant Pest and Disease Control

Plant pests are not planned to be specifically imported into enclosed ecosystems, but they can enter the ECH even with the most careful inspection of planting material. This occurs because fungal spores, bacteria and eggs of insect pests are able to pass a microbiological control.

Agricultural machines that conduct laser treatment of seedlings from weeds have now been developed and are being used for pest control. To ensure healthy growth of green plants, it is suggested, if necessary, to apply primarily physical methods of control that affect pests by means of temperature, light, controlled atmosphere, pressure, ozone generators or plasma [24]. Agricultural drones can be utilized as delivery vehicles for specialized equipment. In the future, with the development of robotics, the methods of physical protection of plants from pests and diseases can be significantly improved by introducing microrobots.

In addition to controlling the conditions of cultivation, biological complex immunomodulators based on chitosan and vanillin as well as preparations derived from natural

sources, can be used for fighting with root rot and other diseases affecting the internal part of plant organisms [25, 26]. They do not require special precaution measures, unlike chemical means, and simultaneously with the protective effect they increase the vegetation rate of plants.

Conclusion

The building of such an engineering system as the ECH requires the development of new high-tech methods of growing plant products. The existing technologies make it possible to breed in space some plant species for food use. Numerous experiments have not revealed any significant obstacles to receiving a large-scale amount of vegetables, fruits and green crops of high-quality nutrient composition beyond Earth; a rich crop can be harvested even in weightlessness under fully artificial light. The current research on studying vegetative processes on orbital stations is mostly experimental in nature and helps to determine the peculiarities of plant breeding under spacecraft conditions. In the future, there will be a need for systems that can produce organic food to ensure a healthy diet for humans during their long stays in enclosed ecosystems, such as the ECH. The development of biotechnologies in space will make it possible to obtain the required amount of plant food, ensuring a subsequent recycling of the organic waste generated. An orbital station with energy supplied from the outside can provide humans with everything they need. Its creation is a difficult but realizable task, as Earth is, in fact, also a large spaceship with its own ecosystem established over billions of years of evolution.

These directions of development of plant obtaining technology in the ECH, if further elaborated, can bring about solutions applicable to biotechnological production in enclosed ecosystems with a comprehensive approach.

References

1. Arkhipova, T.V. *Mirovyye trendy v kosmicheskoy sfere i perspektivy ustoychivogo razvitiya kosmicheskoy otrasli Rossii [World Space Trends and Prospects for Sustainable Development of the Space Industry in Russia]* / T.V. Arkhipova // *Vestnik Altayskoy akademii ekonomiki i prava.* – 2020. – No. 10, pt. 3. – P. 263–268.
2. Sergeev, A.S. *Sovremennyye razrabotki aerokosmicheskoy otrasli dlya realizatsii kosmicheskikh ekspeditsiy [Modern Developments in Aerospace Industry for the Realization*

of Space Expeditions] / A.S. Sergeev, A.Sh. Asadullin, A.A. Trifonov // *Internauka.* – 2018. – No. 19 [53], pt. 1. – P. 82–85.

3. Unitsky, A. *Features of Design of a Residential Space Cluster "EcoCosmoHouse" – Mission, Goals, Purpose* / A. Unitsky // *Non-Rocket Space Industrialization: Problems, Ideas, Projects: Collection of Articles of the II International Scientific and Technical Conference, Maryina Gorka, Jun. 21, 2019 / Astroengineering Technologies LLC; ed. A. Unitsky.* – Minsk: Paradox, 2019. – P. 51–57.
4. Yerakhovets, N. *Principles of Building a Healthy Environment for Human Life, Work, Development and Recreation in EcoCosmoHouse / N. Yerakhovets // Non-Rocket Space Industrialization: Problems, Ideas, Projects: Collection of Articles of the II International Scientific and Technical Conference, Maryina Gorka, Jun. 21, 2019 / Astroengineering Technologies LLC; ed. A. Unitsky.* – Minsk: Paradox, 2019. – P. 139–143.
5. Costa, J. *NASA's Second Pepper Harvest Sets Record on Space Station [Electronic resource]* / J. Costa. – Mode of access: <https://www.nasa.gov/feature/nasa-s-second-pepper-harvest-sets-record-on-space-station>. – Date of access: 11.06.2023.
6. Harvey, B. *Russian Space Probes: Scientific Discoveries and Future Missions* / B. Harvey, O. Zakutnyaya. – New York [et al.]: Springer, 2011. – 514 p.: ill.
7. *Review and Analysis of Over 40 Years of Space Plant Growth Systems* / P. Zabel [et al.] // *Life Sciences in Space Research.* – 2016. – Vol. 10. – P. 1–16.
8. *Sowing the Seeds for Space-Based Agriculture – Part 2 [Electronic resource].* – Mode of access: https://blogs.nasa.gov/ISS_Science_Blog/2013/09/18/sowing-the-seeds-for-space-based-agriculture-part-2/. – Date of access: 09.07.2023.
9. *Veggie (VEG) – ISS Plant-Growth Facility [Electronic resource].* – Mode of access: <https://spaceflight101.com/iss/veggie/>. – Date of access: 05.07.2023.
10. *Determination of Key Parameters of Service Lighting for Plants* / A. Unitsky [et al.] // *Non-Rocket Near Space Industrialization: Problems, Ideas, Projects: Collection of Articles of the V International Scientific and Technical Conference, Maryina Gorka, Sep. 23–24, 2022 / Astroengineering Technologies LLC, Unitsky String Technologies Inc.; ed. A. Unitsky.* – Minsk: StroyMediaProject, 2023. – P. 170–177.
11. *A Low Equivalent System Mass Plant Growth Unit for Space Exploration [Electronic resource]* / R.C. Morrow [et al.] // *35th International Conference on Environmental Systems,*

Rome, Jul. 11–14, 2005. – Mode of access: <https://www.sae.org/publications/technical-papers/content/2005-01-2843/preview/>. – Date of access: 05.07.2023.

12. *Operational Evaluation of VEGGIE Food Production System in the Habitat Demonstration Unit [Electronic resource]* / G. Stutte [et al.] // *41st International Conference on Environmental Systems, Portland, Jul. 17–21, 2011.* – Mode of access: <https://ntrs.nasa.gov/api/citations/20110014431/downloads/20110014431.pdf>. – Date of access: 05.07.2023.
13. *Cawley, J. NASA Teams Persevere Through Plant Challenges in Space [Electronic resource]* / J. Cawley. – Mode of access: <https://www.nasa.gov/feature/nasa-teams-persevere-through-plant-challenges-in-space>. – Date of access: 29.06.2023.
14. *Shakhno, K. Medicinal Plants for EcoCosmoHouse: Selection, Growing Conditions, Scope of Application* / K. Shakhno, N. Zyl // *Non-Rocket Near Space Industrialization: Problems, Ideas, Projects: Collection of Articles of the IV International Scientific and Technical Conference, Maryina Gorka, Sep. 18, 2021 / Astroengineering Technologies LLC, Unitsky String Technologies Inc.; ed. A. Unitsky.* – Minsk: StroyMediaProject, 2022. – P. 281–289.
15. *Razrabotka tekhnologicheskikh podkhodov k polucheniyu al'ternativnogo biotopliva iz vodorosley [Development of Technological Approaches to Obtaining Alternative Biofuel from Algae]* / V.V. Zabolotskikh [et al.] // *Akademicheskii vestnik ELPIT.* – 2019. – Vol. 4, No. 1 (7). – P. 12–38.
16. *Shalygo, N. Meditsinskiye aspekty al'gologii [Medical Aspects of Algology]* / N. Shalygo // *Nauka i innovatsii.* – 2018. – Vol. 2 [180]. – P. 20–23.
17. *Perspektivy primeneniya kosmicheskikh oranzheriy v komplekse sistem zhizneobespecheniya kosmonavtov v usloviyakh lunnoy orbital'noy stantsii, lunnoy bazy i mezhplanetnykh transportnykh korably [Prospects for Using Space Greenhouses as a Part of a Suite of Crew Life Support Systems of a Lunar Orbital Station, a Lunar Base and Interplanetary Transfer Vehicles]* / Yu.A. Berkovich [et al.] // *Kosmicheskaya tekhnika i tekhnologii.* – 2019. – No. 2 [25]. – P. 37–54.
18. *An Overview of Plant-Autochthonous Microorganisms and Fermented Vegetable Foods* / S. Torres [et al.] // *Food Science and Human Wellness.* – 2020. – Vol. 9, iss. 2. – P. 112–123.
19. *Mikrobiom i mikrobiota mochi: sovremennyye predstavleniya i gendernyye osobennosti [Microbiome and Urine Microbiota: Modern Concepts and Gender Features]* /

M.N. Slesarevskaya [et al.] // *Urologicheskiye vedomosti.* – 2022. – Vol. 12, No. 2. – P. 157–165.

20. *Produktsiya uTerra [uTerra Products] [Electronic resource].* – Mode of access: <https://uterra.by/products/>. – Date of access: 03.08.2023.
21. *Samsonov, G.P. Vyrashchivaniye rasteniy s pomoshch'yu aeroponnoy tekhnologii [Growing Plants Using Aeroponic Technology]* / G.P. Samsonov, D.N. Algazin // *Biotekhnologii v sel'skom khozyaystve, promyshlennosti i meditsine: Collection of Materials of the Regional Scientific and Practical Conference of Young Scientists, Omsk, Apr. 25, 2017 / Foundation for Assistance to Small Innovative Enterprises in Science and Technology [et al.].* – Omsk: FGBOU VO Omskiy GAU, 2017. – P. 118–123.
22. *Comparison Between Growing Plants in Hydroponic System and Soil Based System [Electronic resource]* / R. Gashgari [et al.] // *Proceedings of the 4th World Congress on Mechanical, Chemical, and Material Engineering, Madrid, Aug. 16–18, 2018.* – Mode of access: https://avestia.com/MCM2018_Proceedings/files/paper/ICMIE/ICMIE_131.pdf. – Date of access: 29.06.2023.
23. *Prospective Compositions and Methods for the Production of Light Potting Soils for the EcoCosmoHouse* / A. Unitsky [et al.] // *Non-Rocket Near Space Industrialization: Problems, Ideas, Projects: Collection of Articles of the V International Scientific and Technical Conference, Maryina Gorka, Sep. 23–24, 2022 / Astroengineering Technologies LLC, Unitsky String Technologies Inc.; ed. A. Unitsky.* – Minsk: StroyMediaProject, 2023. – P. 248–259.
24. *Antoshin, I.V. Fizicheskiye metody zashchity sel'skokhozyaystvennoy produktsii pri khraneni [Physical Methods of Protection of Agricultural Products During Storage]* / I.V. Antoshin, V.B. Poyda // *Iniitsiativy molodykh – nauke i proizvodstvu: Collection of Articles of the III All-Russian Scientific and Practical Conference for Young Scientists and Students, Penza, Jun. 20–21, 2022 / PSAU; eds. O.N. Kukharev, A.V. Nosov.* – Penza: PGAU, 2022. – P. 15–18.
25. *A Simplified Synthetic Community Rescues Astragalus mongholicus from Root Rot Disease by Activating Plant-Induced Systemic Resistance* / Z. Li [et al.] // *Microbiome.* – 2021. – Vol. 9 [217]. – P. 1–20.
26. *Innovatsionnyye gibridnyye immunomodulyatory rasteniy na osnove khitozana i bioaktivnykh antioksidantov i prooksidantov [Novel Hybrid Modulators of Plant Immune Responses Based on Chitosan and Bioactive Antioxidants and Pro-Oxidants]* / Ye.V. Popova [et al.] // *Sel'skokhozyaystvennaya biologiya.* – 2021. – Vol. 56, No. 1. – P. 158–170.



UDC 631.812.2:631.872:631.878

Humusoponics as a Method of Growing Agricultural Products in the EcoCosmoHouse Conditions

A. Unitsky^{1,2}
Dr. of Philosophy
in Information Technologies
(Transport)

A. Shereshovets²

V. Karnei²

¹ Astroengineering Technologies LLC,
Minsk, Belarus

² Unitsky String Technologies Inc.,
Minsk, Belarus



Humusoponics is considered as a modern plant cultivation technology which involves the production of organic food without the use of soil, an alternative technology to well-known methods (hydroponics, aeroponics, etc.). The results of an experiment on growing lettuce and mustard greens in a nutrient solution containing additives of various components of natural origin – an aqueous extract from uTerra biohumus and uTerra liquid fertilizer – are presented. The possibilities of using this method for obtaining agricultural plants under the EcoCosmoHouse (ECH) conditions have been studied. An analysis of the concentration influence of nutritional supplements on yield, growth rate of green mass and the number of useful elements in grown crops was carried out. The positive effect of uTerra biohumus and uTerra liquid fertilizer on plant growth and development has been confirmed.

Keywords:

biohumus, EcoCosmoHouse (ECH), humusoponics, new technologies, plant cultivation methods.

Introduction

In the modern world, there is a tendency to improve the available methods of plant cultivation. Research into these methods will help to optimize the human habitat under the EcoCosmoHouse (ECH) conditions and continue progress in this advanced area of civilizational development.

As a result of widespread degradation of agricultural soils, the quality of plant products is decreasing and their taste is deteriorating. At the same time, climate change and limited available land resources are jeopardizing traditional methods of cultivating food crops. The continuous growth of the world's population leads to a natural need for an increase in the quantity of food products. In this context, methods of plant cultivation without the use of natural fertile soil are becoming more and more relevant and popular [1, 2].

This article reveals the concept of "humusponics", which implies the application of a nutrient solution with the addition of biohumus. In contrast to aeroponic and hydroponic methods of plant production, humusponics involves the supply of crops with a full range of nutrients from organic and mineral raw materials, the use of associations of thousands of species of agronomically valuable soil microorganisms. The novelty of the present study lies in the introduction of an organic fertilizer based on humic acids and brown coal as one of the components of liquid nutrient medium in the process of growing lettuce and mustard greens.

The main components of the solution intended for plant cultivation without natural soil are uTerra biohumus and uTerra liquid organic fertilizer. These fertilizers are produced in Unitsky's Farm Enterprise by a special technology using agronomically valuable associations of soil aerobic and anaerobic microorganisms, organic additives, including honey and beekeeping products, waste plant products, droppings, manure, etc. [3].

Thus, this article considers promising methods of plant cultivation and their advantages; analyzes modifications of hydroponics solutions; describes the experience of using nutrient medium containing uTerra biohumus extract and uTerra liquid organic fertilizer.

Hydroponics

Let us analyze the specifics of hydroponics [4, 5]. It is a technology of growing crops, in which the roots are immersed in a nutrient solution saturated with all the necessary

macro- and microelements for the complete growth and development of plants. The main advantages of hydroponics include:

- maximizing the exploitation of available space. In contrast to the traditional method of agricultural production, hydroponics allows growing food in vertical systems or on shelves in several tiers, which contributes to the efficient use of limited space and makes it possible to harvest more crops per area unit [6, 7];
- water savings. In hydroponic systems, water is recycled and reapplied, unlike traditional irrigation, which significantly reduces water consumption;
- nutrient control. In hydroponic systems, plants consume more nutrients from the solutions than they would be able to get from the soil. This ensures optimum conditions for crop development and increased yields;
- reduced pesticide content. Closed hydroponics systems can be more protected from pests, which reduces the need for chemical plant protection agents;
- maximum utilization of nutrients. In hydroponics, nutrients are fed directly into the solution, allowing the plant roots to absorb them more efficiently. This significantly reduces the need for fertilizers and decreases pollution of soil and water bodies from chemical substances;
- increased crop yields. Thanks to hydroponics, plants are cultivated under favorable conditions (optimal light, temperature, humidity; access to nutrients), resulting in higher yields and reducing the need to develop new lands for agricultural use;
- saving land area. Hydroponic systems can be deployed vertically or on the roofs of buildings, which is more efficient in densely populated or space-constrained urban areas.

Providing a number of advantages and prospects for productive agriculture, hydroponics plays an important role in the modern world [8].

With the population growth and urbanization, more and more people are moving to cities, which limits access to land plots for traditional agriculture. Hydroponics offers a solution that will make it possible to grow food crops in vertical farms, on the roofs of buildings or even inside containers. This method will contribute to providing a local and sustainable source of food for urban population.

Thanks to this technology, the land unsuitable for traditional agriculture (deserts, highlands or contaminated areas) is used for plant cultivation. This opens up new prospects for agricultural production in regions where it was previously impossible.

In hydroponic systems, the optimal conditions for plants are created at any time of the year, which helps to solve the problem of seasonality and ensure a stable food supply, regardless of climatic conditions in a particular region.

This method allows to control the environment by excluding the use of pesticides and chemical fertilizers, which can have a negative impact on human health. Consequently, the population will receive safe, environmentally friendly and nutritious food products.

Hydroponics is the subject of active research in the field of agriculture. Scientists and engineers are constantly working to develop new technologies and systems to improve efficiency, sustainability and resource savings. Innovations consist in creating upgraded nutrient control systems, automating the growing process, using alternative energy sources, etc. [9, 10].

Methods of Cultivating Plants Using Hydroponics

There exist different hydroponics systems (hydroponic units) that can be used to cultivate plants without the soil. The most common and efficient ones are presented below (Figure 1) [11].

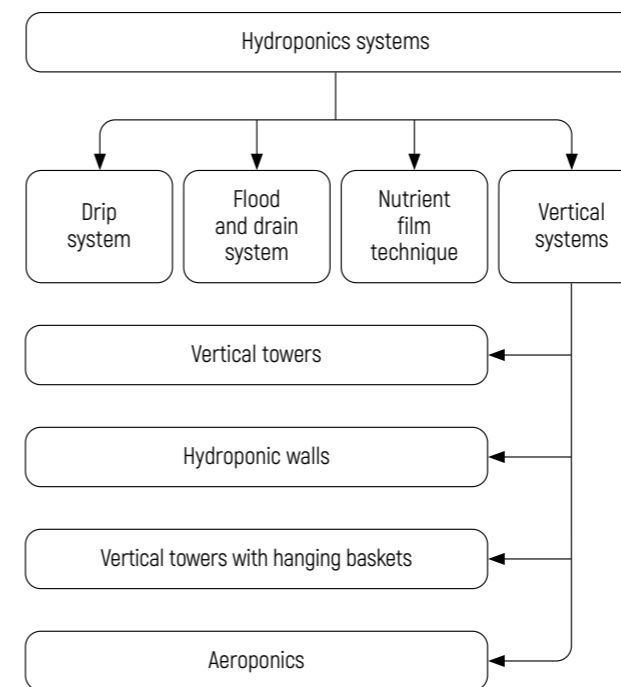

Figure 1 – Methods of cultivating plants using hydroponics

Drip System

It is one of the most popular and simple options. The nutrient solution is delivered to the roots of the plants through tubes with drip emitters, providing them with the necessary nutrients. The system allows a precise control of the amount and regularity of the solution supply and is usually used for growing small and medium-sized crops.

Flood and Drain System

It is based on cyclic flooding and draining of the nutrient solution. Plants are placed in containers or trays that are periodically filled with a nutrient solution and then it is drained back into the tank. This creates cycles of humidity and dryness, allowing the roots to receive nutrients and oxygen in optimal amount. The system is widely used for a variety of plant species, including fruits, vegetables and herbs.

Nutrient Film Technique

Another efficient variant of hydroponics. The nutrient solution circulates continuously in thin film channels through which the roots are laid. The plants receive nutrients from the moving stream. The system provides an optimal nutrition for the roots and is often used for growing greens, salads and herbs.

Vertical Systems

They allow to make optimal use of vertical space and cultivate plants on several levels. Some of the popular systems of this type are presented below:

- vertical towers consist of several levels and each of them provides for planting holes. The nutrient solution is fed from above and passes through the roots, then it is collected and circulated again. Vertical towers utilize space efficiently and make it possible to cultivate a large number of plants in a limited area;
- hydroponic walls involve bedding plants on a vertical surface; they can be located in special modules or panels with planting holes. The nutrient solution is fed from above and passes through the roots, then it is collected and re-circulated. Hydroponic walls are ideal for use indoors and on the facades of buildings;
- vertical towers with hanging baskets in which plants are located. The baskets contain a substrate to hold the roots and allow the crops to grow vertically. The nutrient solution is delivered to the roots through a system of drip emitters or nozzles;

- aeroponics is an upgraded system of hydroponics. Plants are cultivated in the air without the use of a substrate, their roots are immersed in a mist or a fine mist of the nutrient solution that is constantly maintained. The technology provides a high oxygen accessibility for roots and an efficient plant nutrition [12, 13].

Some systems may be homemade, assembled with available materials, while others may be commercial ones, specially designed for hydroponic growing in vertical beds. Each of these systems has its own advantages and specifics. The choice depends on the needs, the space available and the types of plants to be cultivated.

Biohumus in Hydroponic Systems

uTerra biohumus is an organic fertilizer formed in the process of decomposition of relict and modern organic materials under the influence of soil microorganisms and a breed of earthworm *Lumbricus* uTerra, capable of eating brown coal, specially developed at the Unitsky's Farm Enterprise. This article presents the results of the experiment with the biohumus extract, which is obtained by a special technology using an inoculate taken from the world Bank of soils (created at the Unitsky's Farm Enterprise from samples of natural fertile lands, untouched by plow, delivered to Belarus from all continents of the planet – from more than 100 regions of the world). The most important criteria in choosing uTerra biohumus as a component for the hydroponic solution were its beneficial properties as well as the presence of nutrients and biological activity [14].

Humus contains a significant amount of substances necessary for plant growth and development – nitrogen, phosphorus, potassium and microelements. They are slowly released into the soil and become available for absorption by the roots. This helps to maintain a nutrient balance and soil fertility.

Humus is a source of nutrition and habitat for aerobic and anaerobic microorganisms (bacteria, fungi, protozoa) that play an important role in the soil ecosystem. The microorganisms present in humus decompose organic substances, releasing nutrients and creating favorable conditions for plants. In addition, such microorganisms help to fight pathogenic bacteria and fungi, preventing diseases of plantations [15].

Research on development, improvement and analysis of nutrient media for plant cultivation under the ECH conditions is carried out in the Biotechnology Department

of Unitsky String Technologies Inc. (Minsk, Belarus). New solution compositions for an alternative method of manufacturing plant products according to the concept by engineer A. Unitsky [16] are presented below.

Conducting the Experiment

Consumption of greens is an important part of a healthy and balanced lifestyle. Fresh greens (lettuce, dill, parsley, mustard, etc.) are a useful product and contain a number of essential elements and nutrients. It is worth noting that its properties can differ depending on the variety, method of cultivation and cooking.

Lettuce (*Lactuca sativa* L.) of Lattuga variety and charlock mustard (*Sinapis arvensis* L.) of Muravushka variety were chosen as the object of research. This decision is due to their economic and agronomic value as well as fast maturation time.

Lettuce and mustard seedlings were placed in 200 ml containers filled with a nutrient solution (Figures 2, 3).



Figure 2 – Setting up the experiment (lettuce)



Figure 3 – Setting up the experiment (mustard)

Five nutrient solutions were used for comparison. They had a common main base of microelements (Murashige-Skoog medium) and additives of uTerra organic fertilizer in different concentrations as well as a mineral supplement and the extract of uTerra biohumus in different amounts. The extract was obtained by infusing biohumus and water in a ratio of 1 : 2 for seven days. The composition of the standard nutrient medium (control), which is the basis for all experimental solutions, is presented in Table 1.

Table 1 – Components of the Murashige-Skoog medium

Component	Content, mg/l
NH ₄ NO ₃	825
KNO ₃	9,500
KH ₂ PO ₄	85
MgSO ₄ · 7H ₂ O	185
CaCl ₂ · 2H ₂ O	220
FeSO ₄ · 7H ₂ O	13.9
Na ₂ EDTA	18.65
MnSO ₄ · 4H ₂ O	11.15
H ₃ BO ₃	3.1
ZnSO ₄ · 7H ₂ O	4.3
KI	0.41
Na ₂ MoO ₄ · 2H ₂ O	0.12
CuSO ₄ · 5H ₂ O	0.012
CoCl ₂ · 6H ₂ O	0.012

Compositions of nutrient solutions used in the experiment:

- 1) standard solution (control);
- 2) standard solution + 5 % of uTerra biohumus extract;
- 3) standard solution + 10 % of uTerra biohumus extract;
- 4) standard solution + uTerra liquid fertilizer 1 : 500;
- 5) standard solution + uTerra liquid fertilizer 1 : 1,000.

The research conditions were kept constant throughout:

- humidity 50–55 %;
- temperature 22–24 °C;
- illumination 100 μmol/s/m at a distance of 40 cm;
- light wavelength 340–780 nm.

Weekly measurements of vegetative (green) mass growth were made during the experiment.

Main Results of the Experiment

The positive effect of biohumus extract and uTerra fertilizer on the growth and development of lettuce and mustard greens can be noted (Figures 4, 5).



Figure 4 – Lettuce grown by the humusoponics method



Figure 5 – Mustard grown by the humusoponics method

Table 2 shows the numerical result of seedling growth measurement for three weeks of the experiment. The first measurement was made five days after transferring the plants to the hydroponic solution.

Table 2 – Crop growth rates, cm

Composition of nutrient medium	Lettuce			Mustard		
	Day 5	Day 13	Day 21	Day 5	Day 13	Day 21
Standard solution (control)	5.3	9.8	14.2	5.5	15.5	26
Standard solution + 5 % of uTerra biohumus extract	8	13	15.5	5.9	16.5	20.6
Standard solution + 10 % of uTerra biohumus extract	8.1	13.1	15.4	6.3	19.3	23.8
Standard solution + uTerra liquid fertilizer 1 : 500	7.7	14.6	17.8	4.9	16.1	25.2
Standard solution + uTerra liquid fertilizer 1 : 1,000	6.1	9.1	17.3	5.2	16.4	25.2

Figure 6 shows a diagram of lettuce growth on different compositions of nutrient medium over 21 days. The first measurement was made five days after transferring seedlings to the hydroponic solution. The greatest impact on the growth rate of lettuce was made by the composition of nutrient medium "standard solution + uTerra liquid fertilizer 1 : 500"; excellent results were shown by "standard solution + 5 % of uTerra biohumus extract" and "standard solution + 10 % of uTerra biohumus extract". As it can be seen from the diagram, in the period of appearance of three true leaves (day 13) the lettuce on the nutrient medium "standard solution + uTerra liquid fertilizer 1 : 500" began an active growth and reached the best indicator by the end of the experiment.

Figure 7 shows a diagram of mustard growth on different nutrient media compositions over a period of 21 days. The first measurement was made five days after transferring the seedlings to the hydroponic solution.

Upon completion of the experiment with mustard, it is seen that a slight lag in growth is noted on the nutrient composition "standard solution + 5 % of uTerra biohumus extract", the other compositions showed approximately the same result on the 21st day of observation. It follows from the experiment that lettuce and mustard respond differently to additives in nutrient solutions. It can be concluded that so as to maximize yield, it is necessary to study the concentrations of nutrients for various crops in more detail.

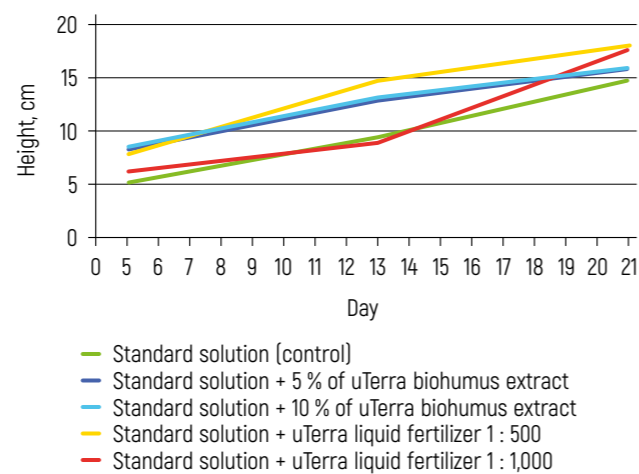

Figure 6 – Lettuce growth over 21 days

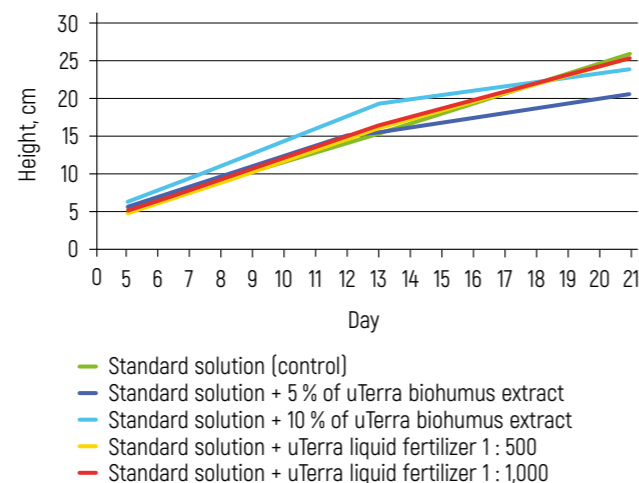

Figure 7 – Mustard growth over 21 days

Table 3 shows the weight of lettuce and mustard plants gained on different nutrient media upon completion of the experiment.

As it can be seen from the data in Table 3, the greatest vegetative mass is gained by the lettuce grown on the nutrient composition "standard solution + uTerra liquid fertilizer 1 : 500": the increase in green mass is three times compared to the control. The second place is occupied by the medium "standard solution + 10 % of uTerra biohumus extract": 2.5 times increase compared to the control.

The mustard grown on the nutrient composition "standard solution (control)" has the smallest green mass. The other variants of the experiment have shown results with a slight difference: about 1.5 times more compared to the control.

Table 3 – Vegetative mass of plants upon completion of the experiment, g

Composition of nutrient medium	Lettuce	Mustard
Standard solution (control)	22.55	21.17
Standard solution + 5 % of uTerra biohumus extract	48.77	26.84
Standard solution + 10 % of uTerra biohumus extract	62.58	26.82
Standard solution + uTerra liquid fertilizer 1 : 500	70.62	30.79
Standard solution + uTerra liquid fertilizer 1 : 1,000	31.03	30.9

Analysis of Chemical Elements

The content of useful minerals for humans, such as calcium and potassium, in lettuce and mustard greens was analyzed in the described experiment. Calcium is the main structural component of bone tissue, it supports a stable cardiac activity, participates in blood clotting processes. Potassium plays an important role in intracellular metabolism, it is involved in muscle function; calcium ions are responsible for the conduction of nerve excitation to the muscles.

Table 4 shows the results of determining the amount of potassium and calcium in the green mass of lettuce and mustard grown using different nutrient solutions. To perform this task, the method of flame photometry on BWB XP Plus Flame Photometers was applied.

Table 4 – Potassium and calcium content in plants, mg/100 g

Composition of nutrient medium	Potassium		Calcium	
	Lettuce	Mustard	Lettuce	Mustard
Standard solution (control)	6,779	7,954	629	730
Standard solution + 5 % of uTerra biohumus extract	7,380	8,462	731	904
Standard solution + 10 % of uTerra biohumus extract	7,863	8,751	710	967
Standard solution + uTerra liquid fertilizer 1 : 500	7,102	8,135	588	820
Standard solution + uTerra liquid fertilizer 1 : 1,000	7,169	8,269	608	830

It is evident from Table 4 that the highest amount of potassium and calcium was observed in the green mass of lettuce and mustard grown on nutrient compositions "standard solution + 5 % of uTerra biohumus extract" and "standard solution + 10 % of uTerra biohumus extract". Compared to the control, the potassium content in lettuce increased on average by 12.5 %, and calcium content – by 14.5 %. Potassium index in mustard has increased on average by 8 %, and calcium – by 24 %. This contributes to improve the nutritional value of crops and active growth of vegetative mass.

An increase in the amount of calcium and potassium in the plants was also recorded when using the nutrient medium with uTerra liquid organic fertilizer. This means that these minerals contained in the initial extract of uTerra biohumus and uTerra fertilizer are in available form for plants and are easily absorbed by them.

Conclusion

The extract from uTerra biohumus as an additive for a nutrient solution in alternative methods of plant cultivation had a positive effect on their development; its use led to an increase in the growth performance rates of lettuce and mustard in relation to the control.

It was revealed that the greatest amount of calcium and potassium minerals useful for humans is present in lettuce and mustard grown on nutrient medium containing biohumus extract.

Vegetative mass formation was best affected by the addition of uTerra liquid organic fertilizer to the nutrient solution. The highest growth was obtained when it was added in concentrations of 1 : 500 and 1 : 1,000. The experimental samples, for which uTerra biohumus extract was used, showed good results in green mass increase. Thus, these natural additives can be considered as an optimal component for the nutrient medium of the alternative method of plant cultivation.

It has been established in the course of the study: different concentrations of biological additives have different effects on the growth at various stages of the plant development. A more detailed study of the concentrations of the involved fertilizers and the rate of nutrient uptake by crops is required to ensure an efficient supply of additives into the standard solution.

Summarizing the above, it is possible to draw a conclusion: the method presented in this work shows the prospects of plant cultivation not only on mineral salts but also using solutions of organic and mineral substances as well as valuable soil microorganisms.

The main emphasis in the construction of the ECH technological platform is put on improving public health and creating a comfortable environment for a long-term human residence. Various means – tools, methods, technologies, etc. – are required in an enclosed ecosystem of the terrestrial biospheric type to maintain life activities. The application of humusponics as a method of obtaining an organic product together with other environmentally friendly biotechnological solutions will allow the ECH residents to maintain autonomy in providing a wholesome organic food under space conditions.

References

1. Yamov, P.S. *Gidroponika [Hydroponics]* / P.S. Yamov // *Aktual'nyye voprosy nauki i khozyaystva: novyye vyzovy i resheniya: Collection of Materials of the LV Student Scientific and Practical Conference, Tyumen, Mar. 17–19, 2021.* – Tyumen: GAU Severnogo Zaural'ya, 2021. – P. 743–746.
2. Boltovskiy, S.N. *Plyusy i minusy gidroponiki [Pros and Cons of Hydroponics]* / S.N. Boltovskiy, S.R. Baymukhambetov, Ye.V. Demchuk // *Novaya nauka: sovremennoye sostoyaniye i puti razvitiya.* – 2016. – No. 12-4. – P. 46–48.
3. *Pochvennyy eliksir universal'nyy uTerra [uTerra Universal Soil Elixir]* [Electronic resource]. – Mode of access: <https://uterra.by/>. – Date of access: 01.06.2023.
4. Karpukhin, M.Yu. *Avtomatizirovannyye gidroponnyye sistemy dlya siti-fermerstva [Automated Hydroponic Systems for City Farming]* / M.Yu. Karpukhin // *Agrarnoye obrazovaniye i nauka.* – 2022. – No. 1. – P. 2.
5. Voronina, M.V. *Ispol'zovaniye metodov gidroponiki v sel'skom khozyaystve [Use of Hydroponics Techniques in Agriculture]* / M.V. Voronina // *Nauchnoye obespecheniye agropromyshlennogo kompleksa: Collection of Articles Based on Materials of the XII All-Russian Conference of Young Scientists, Krasnodar, Feb. 5–8, 2019.* – Krasnodar: Kubanskiy GAU, 2019. – P. 219–220.
6. *Hydroponics as an Advanced Technique for Vegetable Production: An Overview* / N. Sharma [et al.] // *Journal of Soil and Water Conservation.* – 2018. – Vol. 17, iss. 4. – P. 364–371.
7. Sardare, M.D. *A Review on Plant Without Soil – Hydroponics* / M.D. Sardare, S.V. Admane // *International Journal of Research in Engineering and Technology.* – 2013. – Vol. 2, iss. 3. – P. 299–304.
8. *Texier, W. Hydroponics for Everyone. All About Home Horticulture* / W. Texier. – Paris: Mama Editions, 2015. – 336 p.
9. *Tekhnologii budushchego v ovoshchevodstve zashchishchyonnogo grunta: mnogoyarusnaya uzkostellazhnaya gidroponika [Technologies of the Future in Greenhouse Vegetable Production: Multicircle Hydroponics on Narrow Banches]* / T.I. Balashova [et al.] // *Vestnik OrelGAU.* – 2017. – No. 3 (66). – P. 71–74.
10. *Kuryleva, N.V. Gidroponika kak metod vyrashchivaniya zelonykh kul'tur [Hydroponics – a Method of Growing Greens]* / N.V. Kuryleva, A.V. Yurina // *Molodozh' i nauka.* – 2016. – No. 5. – P. 69.
11. *Yur'yeva, Ye.V. Gidroponika i akvaponika kak sovremennyye metody vyrashchivaniya rasteniy i ryby [Hydroponics and Aquaponics as Modern Methods of Growing Plants and Fish]* / Ye.V. Yur'yeva // *Sostoyaniye i puti razvitiya akvakul'tury v Rossiyskoy Federatsii v svete importozameshcheniya i obespecheniya proizvodstvennoy bezopasnosti strany: Materials of the National Scientific and Practical Conference, Saratov, Oct. 4–5, 2016.* – Saratov: Nauchnaya kniga, 2016. – P. 146–150.
12. *Jones, J.B. Jr. Complete Guide for Growing Plants Hydroponically* / J.B. Jones Jr. – Boca Raton: CRC Press, 2014. – 223 p.
13. *Design, Construction and Testing of IoT Based Automated Indoor Vertical Hydroponics Farming Test-Bed in Qatar* / M.E.H. Chowdhury [et al.] // *Sensors.* – 2020. – Vol. 20, iss. 19. – P. 5637.
14. *Piskaeva, A.I. Analysis of Influence of Biohumus on the Basis of Consortium of Effective Microorganisms on the Productivity of Winter Wheat* / A.I. Piskaeva // *Foods and Raw Materials.* – 2017. – Vol. 5, iss. 1. – P. 90–99.
15. *Unitsky, A. EcoCosmoHouse as a Space for the Conservation of Species Diversity of Tropical and Subtropical Flora* / A. Unitsky, V. Pavlovsky, D. Feofanov // *Non-Rocket Space Industrialization: Problems, Ideas, Projects: Collection of Articles of the II International Scientific and Technical Conference, Maryina Gorka, Jun. 21, 2019* / *Astroengineering Technologies LLC*; ed. A. Unitsky. – Minsk: Paradox, 2019. – P. 153–157.
16. *Unitsky, A.E. Programma perezagruzki ekonomiki Soyuznogo gosudarstva Rossii i Belarusi na biosfernyy put' tsivilizatsionnogo razvitiya [Program for Resetting the Economy of the Union State of Russia and Belarus to the Biospheric Way of Civilizational Development]* / A.E. Unitsky. – Minsk, 2022. – 208 p.





UDC 629.78:581.54

Comparative Characteristics of Modern Technologies of Plant Cultivation in Near Space Conditions

A. Unitsky^{1,2,3}
Dr. of Philosophy
in Information Technologies
(Transport)

I. Demenskaya³

A. Kushnirenka^{2,3}

¹ Astroengineering Technologies LLC,
Minsk, Belarus

² Unitsky String Technologies Inc.,
Minsk, Belarus

³ Unitsky's Farm Enterprise,
Maryina Gorka, Belarus



The authors have reviewed several technologies of crop production in near space and identified factors that influence the possibility of its introduction in microgravity and limited space. There is an analysis of the significance of microgravity for the full development of crops. The article describes the technologies proposed by A. Unitsky for breeding plants in near space and the prospects of using these new methods, including for desert gardening. There is also review of the experimental results conducted on the territory of the Unitsky's Farm Enterprise. Also further stages of organic agriculture development on Earth as well as of its application on the Industrial Space Necklace "Orbit" are shown.

Keywords:

desert gardening technology, International Space Station (ISS), magnetism, plants in space, space greenhouse, Sustainable-BioTech, Sustainable Biosphere Cluster (SBC), uGreen technological platform, uTerra.

Introduction

Plant cultivation technologies in near space can utilize a variety of scientific and engineering methods that can achieve results under conditions of weightlessness and increased cosmic radiation.

One of the main common technologies is hydroponics, a method of growing crops in water to which minerals and nutrients are added. In space, hydroponic systems provide plants with the necessary nutrition and water as well as insulation and place for cultivation. To deliver sufficient light and heat to plants, special lighting and heating systems are used, in particular LED lamps that mimic natural sunlight. In addition, special methods are used to create optimal conditions for plant cultivation in near-Earth space. The International Space Station (ISS), for example, has a closed-loop system: all waste is treated and recycled into new sources of food and water for plants [1]. Biologists and astronaut engineers continue to propose new technologies to improve the process of plant cultivation in space and increase yields and product quality.

At present, the topic under consideration is extensively addressed in open information sources. According to data from the Google Scholar, there are over 4 mln publications directly or indirectly related to issues of crop production in space; a patent search yielded more than 1,000 works on this topic [2]. In addition to review articles and patents, the National Aeronautics and Space Administration (NASA) regularly publishes studies on cultivation technologies, conducting experiments both on Earth and in space [3].

We can identify four key research areas that characterize the technology of plant cultivation on orbital stations.

1. Creating devices for growing crops in confined space.

Structurally, these units represent a multifunctional device, greenhouse, rack, box and module. Their main purpose is to facilitate plant production. An example of such a device implemented as a module is the operational vegetable cultivation system Veggie [4]. The project has been active since 2014 and is currently utilized on board the ISS.

2. Development of systems and methods to ensure plant cultivation under conditions of microgravity, limited illumination level and the influence of cosmic radiation. Such systems include:

- artificial soil;
- air conditioning and refrigeration;
- plant fixation;
- artificial lighting;
- crop growth and development control;

- capture and redistribution of CO₂;
- provision of water and mineral nutrition elements;
- automated and robotic monitoring systems.

In particular, an example of a solution to the problem of the gravity effect on crop growth is a patent registered in 2023 for a magnetic device that has a space inside that encompasses the base of the plant and allows it to grow along a vertical axis. Magnetic elements surround the crop in such a way as to create a rotating magnetic field to enhance growth [5].

3. Analysis of plant behavior involving their study at the cellular level in weightlessness; conducting related experiments.

The need for such experiments is due to the environmental effects. Cells behave differently in space than they do on Earth, because the fluids in which they exist move differently in microgravity. So, it is necessary to understand how signals pass between cells, how cells differentiate or divide, grow or metabolize, and what changes are observed in the tissue that consists of them [3]. Research in this area includes experiments on the ISS to cultivate plants in enclosed systems to produce fresh fruits and vegetables. The experiment uses soil microbes to decompose organic material, while the cultures receive substances necessary for growth and development [1].

4. Elaboration of landscaping methods. Thanks to the accumulated experience as a result of experiments and observations, it was possible to create a common system – space greenhouses, a flowering garden. To date, this concept is still at the research stage and has no practical application in near-Earth orbit.

Greenhouses in space are of interest for studying the effects of microgravity and radiation on plants as well as for testing life support systems in long-term missions of spacecraft and various space objects. In addition, such greenhouses may have practical applications in the future when humans begin to colonize other planets. They will need plants to supply food and oxygen and also to create atmosphere on these planets. However, building greenhouses in space is not a trivial task, which requires the development of special technologies and methods of plant cultivation in microgravity and strong radiation [1].

Since the four research areas reviewed reflect changes in human perceptions of plant cultivation technologies in near-Earth orbit, the objectives of this publication are:

- to analyze the current state of crop production technologies used in near space; estimate how present techniques

for creating microbiological preparations and string greenhouses can add to the human understanding of farming in orbit, including how the gained knowledge will enable these technologies to be used when cultivating plants in the extreme conditions of Earth's tropical climate;

- to consider the potential of biosphere technologies to address energy, environmental and other problems effectively, touching upon the practical issue of gardening the Earth's deserts; assess what steps have already been taken towards this objective;

• to forecast the evolution of plant cultivation technologies in orbit; to describe the constraints and formulate proposals for the development of plant cultivation in artificial and extreme environmental conditions, considering current trends; to present the prospects of the project focused on the creation of a biosphere cluster in the UAE.

When preparing the publication, we have tested the use of artificial intelligence (ChatGPT), developed by OpenAI company, for wide coverage of a significant amount of accumulated knowledge in the study area and accelerating the solution of problems in creating a favorable environment for human habitation on Earth and in space.

Prerequisites for Development of Principal Technological Directions of Plant Cultivation in Near Space Conditions

The problems of plant cultivation in extreme conditions on Earth and in orbit (in weightlessness, at high and low temperatures, etc.) are becoming more and more relevant in science and practice and are forming a whole industry. The main trend is the creation of crop production technologies in artificial environment taking into account various factors of the surrounding environment. Every day we find confirmation of this in media publications.

Some examples of the development of such technologies are the watermelon growing experiment completed in 2023 at the Antarctic Vostok Station, in which they applied soilless technology (panoponics) [6], and the harvest of dwarf tomatoes grown on the ISS using the Veggie system (as part of the VEG-05 study) and delivered by an astronaut from the UAE for further analysis at the John F. Kennedy Space Center in Florida [3].

These examples are responses to the challenges facing humanity in the current century. The main factors and drivers

steering the plant cultivation industry forward in Earth's orbit and in extreme agricultural conditions:

- growth of the Earth's population and, consequently, questions about the impact of human activities on the planet and its ability to support life for people and other species [7];
- a focus on achieving food security. Globally, the number of chronically undernourished people exceeded 821 mln in 2018, up from 777 mln three years earlier; 10 of 13 largest food crises in the world are caused by conflict; 60 % of hungry people live in conflict zones [8];
- degradation of land and agricultural areas as a result of excessive use of fertilizers and agrochemicals as well as due to wind and water erosion and construction of highways. The UN reports that up to 12 mln ha of agricultural areas are lost annually due to land degradation, which is 0.2 % of the area of such lands in the world [9];
- slowdown in the global economic growth, which affects developing countries the most and contributes to an increase in the number of hungry people [10];
- local trends related to the development of new areas and territories – on Earth or in outer space [11].

Understanding the above trends, A. Unitsky formulated the thesis: "The biosphere of the planet is our home. More precisely, one large bed-sitting room, which does not even have partition walls" [11].

Characteristic of Modern Technologies of Plant Cultivation in Near Space Conditions

We propose to characterize the evolution of ideas in near space plant cultivation through several aspects:

- stages of technology development life cycle;
- factor model of technology development.

The approach to the study of technology evolution with regard to the evaluation of the industrial life cycle stages was used by many authors of scientific articles [12]. Based on this approach, it is possible to identify the main stages of technological development of crop production in Earth's orbit, which are presented in detail by the team of scientists of the Yu. A. Gagarin Research & Test Cosmonaut Training Center [13]. They managed to trace the development of the technology from the moment the ideas of involving biological elements in the life support systems of piloted spacecraft started in 1895, associated with such names

as K. Tsiolkovsky [14] and F. Tsander, to 1999, when experiments were carried out on the Russian segment of the ISS in the Lada greenhouse. Table 1 shows the stages of development of near space plant cultivation technologies.

Each next stage of technology evolution is associated with the identification and resolution of new problems to overcome the influence of external environmental factors to ensure the possibility of plant cultivation in artificial conditions, including near space. To analyze the impact of such factors on the development of the crop cultivation process in near-Earth space, we propose to use the Ishikawa diagram [15].

In its structure, the main goal of the EcoCosmoHouse project – long-term comfortable human habitation outside the Earth – should be considered as the problem to be solved, which is aimed at the development of plant cultivation technology in near space (Figure 1) [15].

A set of factors influencing the development of plant cultivation technologies in an artificially created environment (in Earth orbit) has been formed during more than 100 years of space exploration. The key ones are:

- microgravity: affects the growth of crops and leads to negative changes in their shape, structure and function;

- radiation: is a serious threat to plants that can cause mutations and DNA damage;

- lack of growing conditions: in the absence of fertile soil, crops must be grown in special containers equipped with artificial lighting and irrigation systems;

- duration of space missions: exploration of Mars, other planets and space objects may require the production of plants over a long period of time;

- limited volume: crops must be grown in a small place of the space station or capsule, which may constrain their number, size and weight characteristics [1].

Below is a fragment of the factors' classification of the plant cultivation process in space (Table 2). This classification is a system of consecutive divisions, which are made in terms of influencing attributes. The factors are grouped so that their position allows us to judge their properties. The final result of the classification is easy to interpret because it is given schematically in the table.

For additional analysis, as the parameter to be studied, we consider the environmental factors such as microgravity and confined space conditions and how they affect plant cultivation.

Table 1 – Characteristics of the development stages of plant cultivation technologies in near space conditions

Stage	Duration	Main results
1. Cultivation concept formation	1895–1950	The vision and role of biotechnological elements in spacecraft life support systems were formulated. The concept of plant cultivation in Earth's orbit was born
2. Start of experiments	1951–1962	The first seeds were delivered to near-Earth orbit. Microgravity influence on bioobjects was studied
3. Confirmation of a number of hypotheses	1962–1988	Scientific and practical experiments on cultivation of crops in near-Earth orbit using various types of installations based on hydroponics have been carried out. The possibility of ontogenetic development and reproduction of plants was confirmed, which determined their use as food by astronauts
4. Beginning of the greenhouse concept development	1988–1999	Genetic consequences of crop cultivation in a number of generations on board the Russian segment of the ISS were revealed. Transition to the concept of creating greenhouses for plant cultivation on a permanent basis was made
5. Development of greenhouse-type technologies	From 2000 to present	Automatic and semiautomatic greenhouse technologies of plant growing have been developed. The number of crops used for cultivation in microgravity conditions has been expanded. An idea of the possibility of creating greenhouses for long piloted expeditions and building them in outer space was formed

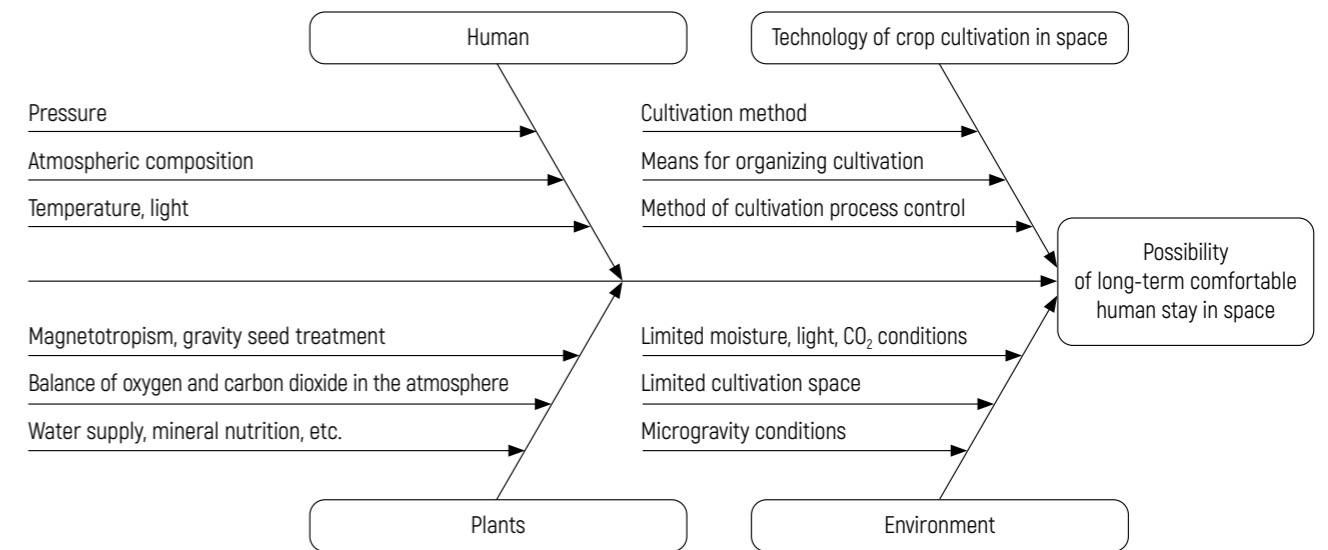

Figure 1 – Ishikawa diagram: factors influencing the development of the technological process of plant cultivation in near space conditions

Table 2 – Fragment of classification of factors of plant cultivation process in the conditions of microgravity and confined space [16–18]

Parameter	2 nd level factor	Factor effect assurance			
		Technology of plant cultivation in space (T)	Human	Plants	Environment
Microgravity conditions	Means for organizing cultivation	Use of a spherical planting surface	Improving the management and control of plant habitats	Selection of crops for cultivation and seed preparation	Increased planting area and luminous flux
	Cultivation method	Root module with capillary-porous insert for planting with passive water supply	Substrate humidity controller with feedback sensor for human control of the parameter	Providing a system of humidification and aeration of the plant root area	Liquid gel form with selected nutrient medium
	Cultivation process control method	Control of water and nutrient medium supply process with a microcontroller (start and duration of irrigation)	Control of consumables and power supply availability	Control of growth rate; plant height and root system measurement	Control of ambient air temperature and humidity as well as CO ₂ concentration
Confined space for cultivation	Means for organizing cultivation	Installation weight – up to 8 kg, power – 115 W	Providing irrigation with a tank	Seeds are either prepared on Earth or obtained in space	Height for crop growth – up to 50 cm
	Cultivation method	Teflon coated cushion containing planting medium as well as fertilizer granules	Visual control	Ovaries without flowers, ripening time – less than 28 days	Selected lighting spectrum of red, blue, green colors
	Cultivation process control method	Semiautomatic system	Availability of power and lighting switches for the system	Absorption of the solution by the root system	Metal frame designed for fixing

Publications between 2010 and 2023 have been devoted to the study of the microgravity effects [19–21]. The team of authors [22] gives a review of the literature data on the intensity of the gravity impact on plants. The object of their research is the study of the crop interaction with a constant component – Earth's geomagnetic field. In addition, they provide information on three main types of magnetotropism, and in particular on the physiological reaction of a growing organ bending under the impact of permanent magnetic poles. Their description is given and the conclusion that magnetic fields of various intensity contribute to the growth and development of different types of crops is formulated. The significance of magnetic field and gravitational factor is considerable for a number of reasons:

- without gravity, plants cannot orient themselves in space and properly direct their growth;
- gravity affects the distribution of growth hormones, which determines the shape and size of the crop: they are synthesized in greater amounts at the top of the plant than at the bottom, which ensures upward growth;
- gravity affects root development – they grow in the direction of gravitational force, which allows plants to become stronger in the soil and get the nutrients and water they need;
- some crops, such as maize, can change the direction of their growth under the effect of gravity. This is due to a special spherical cell that reacts to changes in the position of the plant [1].

Thus, gravity plays an important role in the life of crops and determines their shape, growth and development. In our opinion, the key aspects that will be crucial in the evolution of crop production technologies in a space greenhouse will be:

- minimizing the function of human control of plant condition and transferring it to an automatic system;
- availability of specially selected nutrient agrobiological medium, which is the best for various crops, contributing to their protection from negative environmental impact as well as to the building of an immune system for a genetically developed generation, which would guarantee reproduction in space;
- reduction of plant cultivation installations to a size close to the root system environment, which will allow such devices to be assembled into a single greenhouse;
- increasing the role of the space agronomist, who should correctly select crops, nutrient media, creating proper starting conditions for plant cultivation in space.

However, further human impact on their growth will be minimal and will be reduced only to the function of system monitoring and crop development;

- special design solutions for the arrangement of plants, their root system, nutrient medium supply devices and light, observing the requirements of low energy consumption.

Thus, in more than 100 years, humankind has made significant progress in the study of near space crop production technologies. At the same time, going from the general to the particular, they have been largely divided by scientific groups and corporations. Further development of technologies is possible due to the processes of integration of world experience to solve a single task – creation of the world's first space greenhouse. This mission could be entrusted to the International Organic Farming Association, which is proposed to be established in the UAE.

Realizing the trends in the evolution of plant cultivation technologies in near space conditions, A. Unitsky on the basis of the Unitsky's Farm Enterprise together with the world engineering school of Unitsky String Technologies Inc. developed a comprehensive agro-biotechnological engineering system called Sustainable-BioTech, combining innovative engineering, agro-, bio- and soil-forming technologies.

This system includes the following key stages:

- use of relict raw materials of organic origin such as brown coal and oil shale as the main source of macro-, micro- and ultramicroelements (included in the composition of ancient living organisms), prepared with the use of technological conversion stages until it is possible to extract humic substances (humic acid salts);
- addition of any modern raw materials of organic origin: grass, peat, sawdust, manure, household waste, sewage;
- final processing of the obtained multicomponent mixture into living fertile humus in bioreactors with associations of thousands of particular selected species of agronomically valuable soil microorganisms that enter into symbiosis with plants grown on this humus.

Such microorganisms are taken in a special way from the world soil cluster (Figure 2). It is located in Maryina Gorka, Belarus, in the territory of Unitsky's Farm Enterprise. The cluster is a set of fertile soils, untouched by the plow, collected in more than 100 regions from all continents of the planet. As a result, each kilogram of organic biohumus contains up to 10 tln useful bacteria of thousands of species, providing nutrients to plants, and exactly in the amount they need for effective vital activity.



Figure 2 – World soil cluster, Unitsky's Farm Enterprise, 2023

Honey and other beekeeping products containing a complex of vitamins, amino acids, organic acids, enzymes and minerals (macro-, micro- and ultramicroelements) are included as additional nutrition for these microorganisms during their reproduction and cultivation. These and other useful (therapeutic and even healing) components, then produced by soil microorganisms, which form a symbiosis with the root system of plants, are transferred into organic food produced on such bio-soil. The concentration of agronomically valuable soil microorganisms in 1 l of uTerra organic complex plant nutrition, obtained by the above technology, is not less than 1 tln colony-forming units (Figure 3).

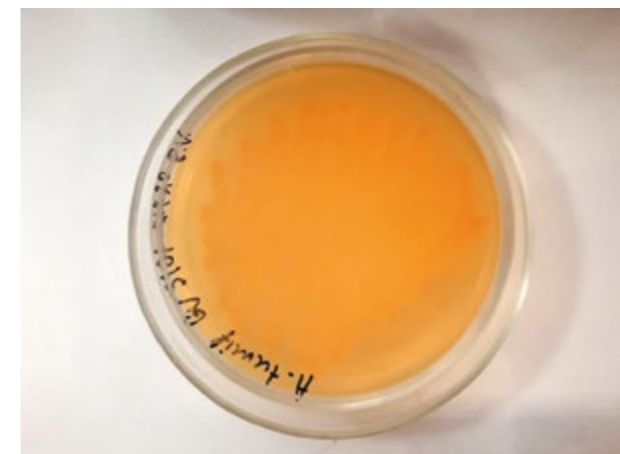

Figure 3 – Association of microorganisms isolated from the world Bank of fertile, untilled soils by the Biotechnology Department of Unitsky String Technologies Inc., 2023

The crumbly biohumus for uTerra production is created as a result of vital activity of the earthworm species *Lumbricus* uTerra specially bred by Unitsky's Farm Enterprise (Figure 4), which is able to eat not only modern organic matter but also relict raw materials of organic origin – brown coal and oil shale.



Figure 4 – Earthworm species *Lumbricus* uTerra bred by Unitsky's Farm Enterprise, 2023

A unique component of the agro-biotechnological part of the Sustainable-BioTech system is elicitors that accelerate the process of delivery of nutrient elements required for plants. The formed basis is used to obtain:

- uTerra – a unique composition of liquid organic complex fertilizer for plants;
- uTerra Oasis – a soil elixir adapted to hot climates.

The engineering part of the system provides the necessary temperature and other effects on the initial components, while preserving the value of each of its elements.

Thanks to carefully selected (within a narrow range of parameters) equipment operation modes, ingredient and fractional composition, concentration of components, values of hydrogen indicator pH and other process modes, optimal conditions are created for maintaining the balance between sources of macro-, micro- and ultramicroelements and maintaining a working environment for associations of thousands of species of agronomically valuable soil microorganisms. The synergy of microelements and biotechnological modes of obtaining a product determines the enhanced effect on the immune system of crops, contributing to their healthy growth and development. The applied process equipment, its volumes, used materials and process modes

ensure production and economic efficiency of the entire complex agro-biotechnological engineering system Sustainable-BioTech. As a result of its implementation in the territory of Unitsky's Farm Enterprise, the yield of vegetable, berry, green and other crops increased by 20–35 %. The result is visualized in Figure 5.

Unitsky's Farm Enterprise is a working model of the uGreen technological platform created by farmer A. Unitsky [23–25], focused on the possibility of using available developments for cultivating plants in space and gardening deserts on Earth. The experience of restoring low fertile and degraded soils on the territory of the farm (former tank range) using the Sustainable-BioTech system can also be applied in the ongoing international programs for the restoration and conservation of fertile lands.

Implementation of this system is also possible in the UAE by organizing Sustainable Biosphere Cluster (SBC) (Figure 6) as a center of competence in gardening deserts.

SBC will be the basis for the implementation of the uGreen technological platform in hot tropical climates, an environment with negative impact factors (e.g., high temperature) affecting plant cultivation. The essence of the platform is organic farming in a new logic of recreating and intensifying natural biosphere processes by directly borrowing and using natural soil ecosystems with their microflora, microfauna and biogeocenosis as well as in the logic of a complete refusal to use any synthetic chemicals (fertilizers and plant protection products), gene modification technologies and other elements of conventional intensive farming.

In order to establish the processes of integration of uGreen technological platform into agricultural turnover, we propose to establish SBC as a biotechnological engineering and scientific platform to facilitate the testing of the world's accumulated knowledge in the field of extreme agriculture, in order to create the first space greenhouse as well as to participate in international programs, including:

- Great Green Wall (Africa). Proposed by the African Union to stop soil degradation and organize 8,000 km long green belts across Africa [26];
- Great Green Wall (China) (the Three-North Shelter Forest Program). Supports the adjustment of groundwater to provide conditions for crop growth in China's desert regions [27];
- Middle East Green Initiative. The project, promoted by Saudi Arabia, aims to reduce carbon dioxide emissions in the region. It envisages increasing the green cover by planting more than 50 bln trees in the Middle East and restoring 200 mln ha of degraded land [28].



Figure 5 – Vegetables, berries, greens grown with uTerra fertilizer, 2023



Figure 6 – SBC territory: experimental greenhouse in a hot climate (visualization)

Conclusion

Consideration of the evolution stages of plant cultivation technologies in near space conditions and compilation of a multifactor model of this process allow predicting further development and improvement of these technologies with their full materialization on Earth – in gardening deserts. The first practical experience of solving the global problem, implemented in Belarus, confirmed the possibility of organic farming and achieving actual results. The next step in this direction is the creation of SBC in the UAE.

The establishment of SBC will help to create food production using organic feeds to nourish plants in the tropics and deserts. Having ensured the safety of organic food production on Earth in extreme natural and climatic conditions, it is possible to prepare technologies for their application in near space – in the ECH.

Due to the importance of the cost factor in the transportation of nutrient soil medium for the implementation of the most economical way of growing crops in near-Earth space, while creating SBC the principles of economic efficiency are taken into account.

To analyze the negative factors of plant cultivation in near space, we plan to study the effect of complex fertilizers containing humic acid salts on the presence of heavy metals and radionuclides in plant products. The results of the research will provide an opportunity to finalize these fertilizers and use them for step-by-step restoration of fertility of technogenically contaminated soils on the planet, including radiation impact.

References

1. ChatGPT: Online AI Chatbot [Electronic resource]. – Mode of access: <https://chatgpt.org/>. – Date of access: 01.06.2023.
2. PATENTSCOPE [Electronic resource]. – Mode of access: <https://patentscope.wipo.int/search/ru/search.jsf>. – Date of access: 01.06.2023.
3. How to Grow Plants in Space [Electronic resource]. – Mode of access: <https://www.nasa.gov/podcasts/curious-universe/how-to-grow-plants-in-space/>. – Date of access: 01.06.2023.
4. Zolotukhina, D.A. Avtomatizirovannyye sistemy vyrashchivaniya rasteniy v usloviyakh kosmicheskogo polota [Automated Systems for Growing Plants in Space Flight Conditions] [Electronic resource] / D.A. Zolotukhina. – Mode of access: <https://cyberleninka.ru/article/n/avtomatizirovannyye-sistemy-vyrashchivaniya-rasteniy-v-usloviyah-kosmicheskogo-polota>. – Date of access: 11.09.2023.
5. Magnetic Device and Method for Growing Plants [Electronic resource]: Patent US11612109 / W.R.D. Wimaladharm. – Published 28.03.2023. – Mode of access: https://patentscope.wipo.int/search/ru/detail.jsf?docId=US394127949&_cid=P21-LQYVY8-35909-1. – Date of access: 01.06.2023.
6. Na antarkticheskoy stantsii "Vostok" vyrastili arbuzy [Watermelons Grew at the Antarctic Vostok Station] [Electronic resource]. – Mode of access: <https://www.aari.ru/press-center/news/novosti-aari/ambuzy>. – Date of access: 31.07.2023.
7. Na ekologii skazyvayetsya ne stol'ko rost chislennosti naseleniya, skol'ko rost dokhodov [Environment is Affected Not So Much by Population Growth as by Income Growth] [Electronic resource]. – Mode of access: <https://news.un.org/ru/story/2022/02/1418822>. – Date of access: 11.07.2023.
8. Fact Sheet: Hunger and Conflict [Electronic resource]. – Mode of access: https://docs.wfp.org/api/documents/WFP0000105972/download/?_ga=2.126346895.364624701.1700740337-582051363.1700740337. – Date of access: 31.07.2023.
9. Every Year, 12 Million Hectares of Productive Land Lost, Secretary-General Tells Desertification Forum, Calls for Scaled-Up Restoration Efforts, Smart Policies [Electronic resource]. – Mode of access: <https://press.un.org/en/2019/sgsm19680.doc.htm>. – Date of access: 31.07.2023.
10. UNCTAD Calls for a Bold International Economic Agenda to Avert Another Lost Decade for Developing Countries [Electronic resource]. – Mode of access: <https://unctad.org/news/unctad-calls-bold-international-economic-agenda-avert-another-lost-decade-developing-countries>. – Date of access: 31.07.2023.
11. Non-Rocket Space Industrialization: Problems, Ideas, Projects: Collection of Articles of the II International Scientific and Technical Conference, Maryina Gorka, Jun. 21, 2019 / Astroengineering Technologies LLC; ed. A. Unitsky. – Minsk: Paradox, 2019. – 240 p.
12. McGahan, A.M. Context, Technology and Strategy: Forging New Perspectives on the Industry Life Cycle / A.M. McGahan, N. Argyres, J.A.C. Baum // Business Strategy over the Industry Life Cycle. – 2004. – Vol. 21. – P. 1–21.
13. Kryuchkov, B.I. Biotekhnicheskkiye sistemy zhizneobespecheniya dlya ekipazhey pilotiruyemykh kosmicheskikh kompleksov [Biotechnical Life Support Systems for Crews of Manned Space Complexes] / B.I. Kryuchkov, V.M. Usov,

- Ye.V. Popova // *Vozdushno-kosmicheskaya sfera*. – 2020. – No. 3 (104). – P. 82–89.
14. Tsiolkovskiy, K.E. *Vne Zemli [Outside the Earth] [Electronic resource]* / K.E. Tsiolkovskiy. – Mode of access: <https://www.tsiolkovsky.org/wp-content/uploads/2021/09/280-tsiolkovsky-sbornik-vne-zemli-2008.pdf>. – Date of access: 31.07.2023.
 15. Grishina, T.G. *Opredeleniye faktorov, vliyayushchikh na tekhnologicheskii protsess [Identifying the Factors That Affects Technological Process]* / T.G. Grishina, A.N. Feofanov, G.V. Yudin // *Mezhdunarodnyy nauchno-issledovatel'skiy zhurnal*. – 2016. – No. 7, pt. 4. – P. 14–17.
 16. Yemel'yanov, A.Yu. *Issledovaniye faktorov tekhnologicheskogo razvitiya predpriyatiy [Study of Factors Technological Development of Enterprises]* / A.Yu. Yemel'yanov, T.A. Petrushka // *Problemy ekonomiki i menedzhmenta*. – 2013. – No. 11 (27). – P. 13–21.
 17. *Kosmicheskiye oranzheri: nastoyashcheye i budushcheye [Space Greenhouses: Present and Future]* / Yu. Berkovich [et al.]. – Moscow: Slovo, 2005. – 368 p.
 18. *Veggie [Electronic resource]*. – Mode of access: https://www.nasa.gov/wp-content/uploads/2019/04/veggie_fact_sheet_508.pdf. – Date of access: 31.07.2023.
 19. Bogatina, N.I. *Vliyaniye elektricheskikh poley na rasteniya [Influence of Electric Fields on Plants]* / N.I. Bogatina, N.V. Sheykina // *Uchonyye zapiski Tavricheskogo natsional'nogo universiteta im. V.I. Vernadskogo*. – 2011. – Vol. 24 (63), No. 1. – P. 10–17.
 20. Zakhvatova, O.V. *Issledovaniye gravitatsionnogo vliyaniya na posevnyye svoystva semyan prosa [Investigation of Gravitational Impact on the Sowing Properties of Millet Seeds] [Electronic resource]* / O.V. Zakhvatova, A.V. Migulina. – Mode of access: <https://cyberleninka.ru/article/n/issledovanie-gravitatsionnogo-vliyaniya-na-posevnye-svoystva-semyan-prosa>. – Date of access: 11.09.2023.
 21. *Evolution of Fast Root Gravitropism in Seed Plants* / Y. Zhang [et al.] // *Nature Communications*. – 2019. – Vol. 10 (1). – 3480.
 22. Bogatina, N.I. *Vliyaniye magnitnykh poley na rasteniya [Influence of Magnetic Fields on Plants]* / N.I. Bogatina, N.V. Sheykina // *Uchonyye zapiski Tavricheskogo natsional'nogo universiteta im. V.I. Vernadskogo*. – 2010. – Vol. 23 (62), No. 4. – P. 45–55.
 23. Unitsky, A. *Features of Design of a Residential Space Cluster "EcoCosmoHouse" – Mission, Goals, Purpose* / A. Unitsky // *Non-Rocket Space Industrialization: Problems, Ideas, Projects: Collection of Articles of the II International Scientific and Technical Conference, Maryina Gorka, Jun. 21, 2019 / Astroengineering Technologies LLC; ed. A. Unitsky*. – Minsk: Paradox, 2019. – P. 51–57.
 24. Unitsky, A. *Tsivilizatsionnaya yomkost' kosmicheskogo doma po imeni Planeta Zemlya [Civilization Capacity of the Space Home Named Planet Earth]* / Anatoli Unitsky. – Minsk, 2021. – 148 p.
 25. Unitsky, A. *The World Engineer: Autobiography* / Anatoli Unitsky. – Minsk: Paradox, 2023. – 496 p.: ill.
 26. *Velikaya zelonaya stena [Great Green Wall] [Electronic resource]*. – Mode of access: <https://707.su/iRGO>. – Date of access: 01.06.2023.
 27. *Zelonaya kitayskaya stena [China's Green Wall] [Electronic resource]*. – Mode of access: <https://707.su/NITO>. – Date of access: 01.06.2023.
 28. *MGI Target: Plant 50 Billion Trees Across the Middle East [Electronic resource]*. – Mode of access: <https://www.greeninitiatives.gov.sa/about-mgi/mgi-targets/planting-trees/>. – Date of access: 01.06.2023.





UDC 574.24

Project of Creating the Enclosed Ecosystem uBioSystem for the Infinitely Long Autonomous Existence of Living Organisms

A. Unitsky^{1,2}
Dr. of Philosophy
in Information Technologies
(Transport)

A. Pauliuchenka²

P. Buglak²

I. Naletov²

N. Zyl²

P. Naumchik²

¹ Astroengineering Technologies LLC,
Minsk, Belarus

² Unitsky String Technologies Inc.,
Minsk, Belarus



The uBioSystem project is described, which is an enclosed ecosystem with controlled technological processes (lighting, temperature, air blow-off, water flow speed, etc.), designed for the autonomous and lasting existence of a community of living organisms. The proposed technical and biological solutions make it possible to control the natural cycles of nutrients and carry out long-term monitoring of all key parameters affecting the studied cycles of substances.

Keywords:

cycle of elements, EcoCosmoHouse, enclosed ecosystem, sustainability of ecosystems, uBioSystem.

Introduction

The relevance of biosphere research is continuously increasing due to the negative results of irrational human impact on the environment. The constant deficit of water resources [1] is not only a threat to people life but also complicates agriculture, which leads to additional soil degradation and a decrease in the species diversity of organisms living in it. Waste continues to grow significantly, while the percentage of its utilization and neutralization reduces every year. The total area occupied by waste is more than 4 mln ha [2], and at least 400,000 ha are allocated for their disposal every year. Such pressure threatens to reduce biodiversity in the biosphere and to lose entire natural complexes. Agricultural land is losing fertility due to the mismatch between natural opportunities and the established land use pattern. According to UNEP, nowadays deserts of anthropogenic origin occupy more than 9 mln km², and annually 7 mln ha are taken out of the productive application [3]. The above facts indicate the onset of an ecological crisis, the way out of which will be the non-rocket near space industrialization. This will leave on Earth industries that either do not have a harmful impact on the biosphere or are efficient enough to restore natural resources as well as those that humanity cannot do without.

Research on Biosphere Using Enclosed Ecosystems

Despite the fact that there is a huge amount of accumulated but often disparate data on the structure of the biosphere, there are currently no accurate, reliable and validated predictive models for the significant changes brought about by the today human activity. In order to implement cognitive agency for long-term planning and elimination of consequences of irrational anthropogenic impact, the biosphere processes are studied on the basis of artificial analogs of ecosystems with enclosed cycles of matter, energy and information. Such models and the technologies used in them can be applied in space exploration, arrangement of autonomous settlements on Earth and other planets. The EcoCosmoHouse concept [4] demonstrates the possibility of creating enclosed ecosystems with unlimited lifetime, solves actual scientific and practical problems, involves modeling and control of biosphere processes and also serves as an alternative to specially protected natural areas that are constantly subject to the negative impact of external factors.

Attempts to arrange such systems are being made in the USA (Biosphere 2), Europe (MELISSA), Japan (Ecotron),

Russia (BIOS) as well as in Canada and China. The practical implementation of some of them (Biosphere 2, BIOS) showed underestimation of key natural processes and relationships. A weak elaboration of the main cycles of biogenic elements led to an increase in water acidity (due to dissolution of excess CO₂). The lack of oxygen was caused by respiration of soil microorganisms, which could not fulfill their functions in the changed environment. This led to increased decomposition of dead organic matter, which in turn absorbed oxygen. In addition, unaccounted trophic interactions had a significant impact, resulting in a decrease in the diversity of animal life. However, the main factor of failures was the absence of a balanced soil cover with the biota inhabiting it.

Taking into account the experience of previous studies, the project of the enclosed ecosystem uBioSystem (Figure 1) was developed for the long-term existence of a community of living organisms, which includes additional technological processes meeting its needs.

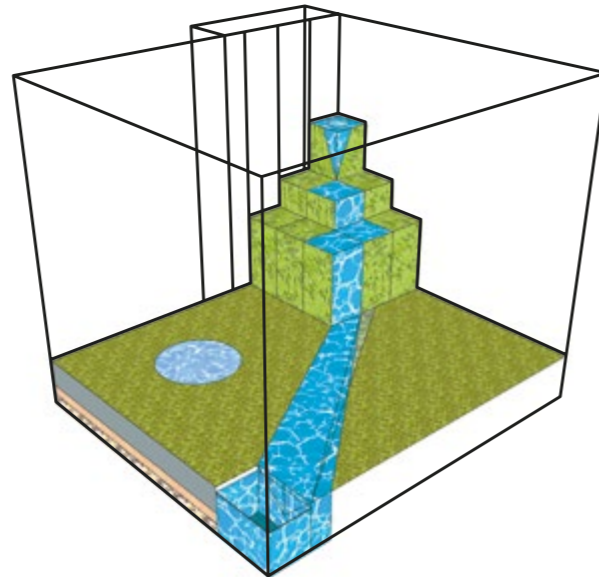

Figure 1 – Enclosed ecosystem uBioSystem

Structure and Components of uBioSystem

The uBioSystem is a model of an environment with fully enclosed cycles of substances in its internal space. The abiotic parameters required by the ecosystem are provided by the following elements:

- surface modules (bottom, side, top);
- elevation modules;

- module of a streambed and two lakes;
- microclimate control system;
- lighting system;
- water circulation system;
- control and management system.

All uBioSystem surfaces must hermetically seal the interior space and be strong enough to withstand pressure from the inside. The bottom surface module (Figure 2) should consist of a thermally conductive metal (e.g., duralumin) and have heating elements under it (with a possibility of adjustment in the range of 15–50 °C) to heat and maintain the temperature inside the ecosystem. In addition, this

module has a direct uniform slope for independent water drainage to the lower point of water intake and to create a slight temperature differential at opposite edges for natural convection.

The side walls of the uBioSystem (Figure 3) are planned to be made of a transparent thermo-insulating material. In order to obtain the results of biosphere processes studies, continuous monitoring is required, which can be performed through transparent surfaces that are inert to temperature changes (this prevents the formation of condensation on the inner walls) and also have sufficient strength to withstand pressure from ecosystem components. The most significant pressure on the side surfaces will be from the soil system.

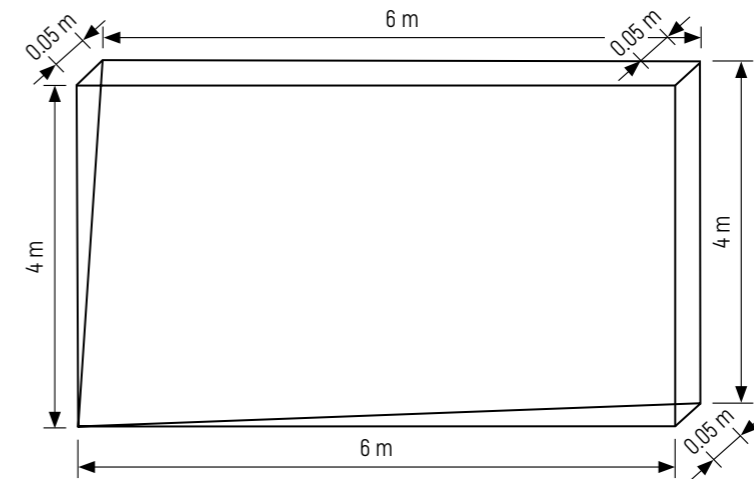

Figure 2 – uBioSystem bottom surface module

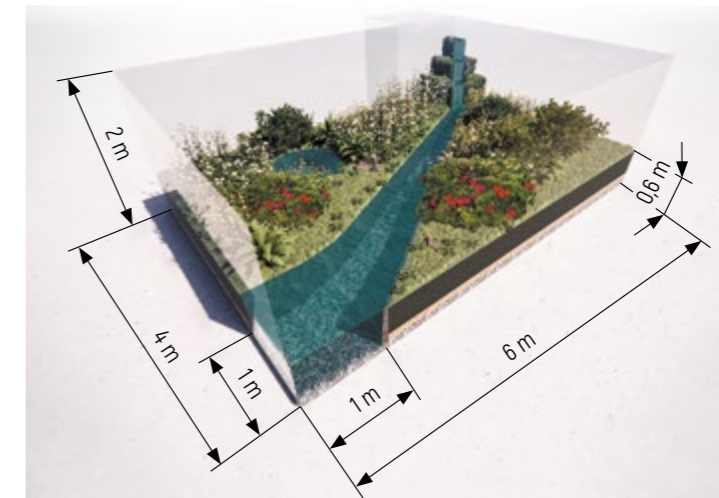

Figure 3 – uBioSystem (visualization)

Environmental Characteristic of uBioSystem Soil

The most important component of an enclosed ecosystem is balanced soil. It is in it that biological and chemical cycle of substances interact through bacterial microorganisms, protozoa and fungi. In addition, the soil is a medium for a huge number of animals, which in the process of life activity regulate most of the flows of matter and energy. The food webs of soil communities that distribute the ecosystem energy flows have a complex structure and are represented by a wide range of organisms forming multiple trophic relationships that are variable in time and conditions [5]. The energy base of soil detrital chains is leaf, root and tree waste of plants. At the same time, energy can be supplied to soil food webs with lifetime root secretions, from living phytomass of plants and during the assimilation of stabilized soil organic matter [6].

The chemical composition of leaf waste is heterogeneous. It includes water-soluble organic components and hemicellulose, which begin to decompose immediately, while the breakdown of cellulose and lignin takes several years. The decomposing organic matter is digested by bacteria and fungi along the trophic chain or passes into detritus (Figure 4).

Actively multiplying bacteria and fungi utilize the most readily available components of the waste, and then it is repopulated by microorganisms decomposing stable organic polymers. Thus, a temporal-spatial succession of decomposition of plant residues takes place in the soil litter. However, even at its late stages, microorganisms utilizing readily available components are present in the microbial community. A fresh tree waste can be assimilated by zygomycetes (*Mucorales* order) as well as by some ascomycetes (*Talaromyces*, *Penicillium* genus, etc.); pectin and cellulose are decomposed by hydrolytic fungi (*Aureobasidium*,

Chaetomium, *Cladosporium*, *Trichoderma*, *Gliocladium* genus). During the first months, saprotrophs from the lignolytic group, which are not capable of rapid growth but master more inert chemical components, begin to develop on the tree waste. These are mostly basidiomycetes (*Marasmius*, *Mycena* genus). Soil fungi of different groups (*Mortierella ramanniana*, *Trichoderma viride*, *Penicillium* species) are the last ones to start dominating on the tree waste.

The third trophic level consists of invertebrate animals. Wood lice, earthworms, diplopods and some insect and mite larvae use plant tissues as food, but these are mainly organisms with a mixed plant-animal diet, which depends on the life cycle. Mites, collembolae and nematodes consume colonies of bacteria and fungi. Detritophages (oribatids, enchytrids) can also be referred to this level.

The next consumptive level consists of zoophages (ground beetles, mole crickets, spiders), phytozoophages (diptera, malacophages; less frequent than at the previous level) and parasites (mites).

Thus, there should be more than three trophic levels in soil webs. An important role is played by polyphages, which partially integrate different energy flows at the level of saprophagous animals. Combining food specialization (it allows to avoid interspecies competition maintaining a high diversity of soil fauna) with temporary polyphagy (it increases the compensating capacity of the soil community and the interchangeability of its components), polyphages are one of the main elements of enclosed ecosystems.

A balanced fertile soil cannot exist without another key component – the earthworm. It is that loosens up the soil, providing respiration and moisturizing of roots, enhances humus formation processes, nitrification and ammonification as well as maintains the necessary number of microorganisms valuable for soil.

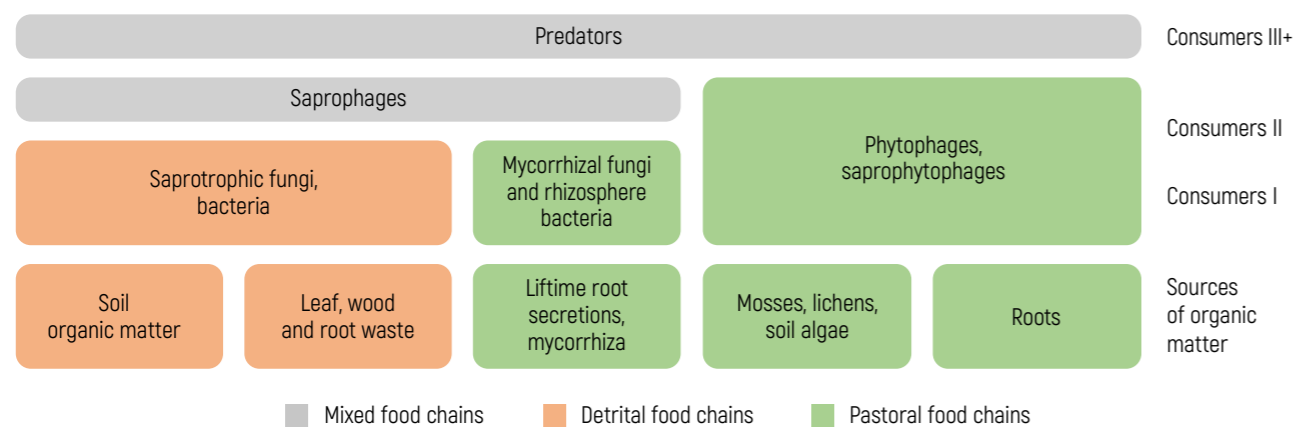

Figure 4 – General diagram of soil trophic web

The digestive tract of the earthworm reduces the number of pathogenic microorganisms and simultaneously promotes the conversion of organic matter into poorly soluble but biologically accessible salts of humic acids. As a result, plant nutrition is accumulated that is resistant to washout from the soil by precipitation. *Eisenia fetida*, *Eisenia andrei*, *Dendrobaena veneta*, in addition to the ability to utilize organic waste naturally, have a high rate of absorption, digestion and assimilation of organic substances, tolerance to a wide range of environmental factors as well as a high rate of reproduction with a short period of sexual maturity.

The introduction of worms should be done comprehensively: a mixture of cocoons (minimum 14,500), juveniles (minimum 8,000) and sexually mature worms of each species is added to each square meter and covered with a feeding substrate. Such a quantity will be sufficient [7] to form a sustainable population similar to the natural one (with a density of at least 50 specimens per 1 m²). Considering that one such population in ideal conditions daily passes through its digestive tract 25 g of soil (250 kg/ha per day) [8], turning it into coprolites, and that the humus content in coprolites of worms is 11–35 %, it is possible to calculate the rate of humus formation per year – from 1 t/ha.

The processes of energy transformation in the soil and its trophic web remain insufficiently studied. This is due to the high diversity of soil inhabitants, trophic connections between them and a huge number of nonstationary biochemical processes. Despite the multitude of models and data, most of them are theoretical and are not supported by practical experiments. Thus, taking into account the fact that there is still no complete understanding of all processes in the soil, its structure and composition should be determined on the basis of natural ecosystems.

Components of the uBioSystem soil:

- 5–10 cm – a layer of natural stones and expanded clay. The lower layer, which will allow the groundwater to flow to the lowest point from where it will be pumped up to the waterfall of the upper elevation module. The stones used (dolomite, limestone, slate, granulated volcanic lava) have a relatively low density and sufficient thermal conductivity as well as serve as a source of valuable macro-, micro- and ultramicroelements, at the same time being a home for valuable bacterial cultures;

- 10 cm – a layer of sand-coal-clay mixture. It will create the necessary support for the relief. Due to its composition, it is difficult to be permeable to air, so that anaerobic bacteria can survive in the lower layers of the soil and participate

in the circulation of unique elements (zinc, sulfur, iodine, manganese, boron, selenium, etc.) [9];

- 40 cm – a layer of light potting soil [10] – a fertile soil (biohumus) with mineral components (perlite, expanded clay). It has a balance of all macro-, micro- and ultramicroelements, correct microbiological composition and does not contain harmful impurities.

Based on the list of soil system components, the pressure on the side surfaces of the uBioSystem can be calculated using the formula:

$$p = \rho gh,$$

where p – pressure, Pa;

ρ – substance density, kg/m³;

g – gravitational acceleration, m/s²;

h – substance height, m.

The density of the components was considered using maximum values reported in the literature or measured independently:

- bottom layer – 3,000 kg/m³ [11];
- perlite – 150 kg/m³;
- expanded clay – 400 kg/m³;
- sand – 2,000 kg/m³ [12];
- clay – 2,000 kg/m³ [13];
- light potting soil – 142 kg/m³ [10].

Table 1 summarizes the pressure of each soil layer on the walls of the enclosed ecosystem.

Table 1 – Pressure calculation of the main components of the uBioSystem soil

Component	Density, kg/m ³	Height, m	Pressure on surface, Pa
Stone	3,000	0.05	1,473
Sand	2,000	0.05	982
Clay	2,000	0.05	982
Soil	142	0.4	558
Total			3,995

Based on the specified components (up to 60 cm in height) and taking into account that the calculation does not include the mass of water, animals and plants as well as elevation modules, stream and water body, each surface

and facet of the uBioSystem must withstand a pressure of at least 0.1 MPa. With the known area (24 m²), height (0.6 m) and component composition of the soil system, its average pressure per 1 m² is calculated to be 107 kg.

Specific Features of the uBioSystem Design

The side surface modules of the uBioSystem are combined with the lighting system. The LED luminaires are mounted directly into the wall at a height of between 0.6 and 2 m, which allows to simulate the rising sun by gradually changing the lighting spectrum, switching off the lower lamps over time and switching on the remaining rows. The top module is equipped with lamps with a spectrum corresponding to the zenith. This surface should be additionally

pierced through (while maintaining the tightness of the interior space) with thin metal cones. From the outside, a cooling circuit is connected to them to adjust the air temperature inside the enclosed ecosystem, and the cones themselves collect and then discharge water condensate (for uniform irrigation).

On a clear day, the level of natural photosynthetically active radiation (PAR) increases by 100 μmol/s/m² 30 min before peaking at about 2,000 μmol/s/m² at noon [14]. The main difference of moonlight is that it reaches a maximum in the red part of the spectrum (643 nm) at the zenith on a clear night. Thus, the accumulated knowledge in the field of day and night lighting and the described technological solutions make it possible to put into practice solar and lunar cycles (Figure 5) in an enclosed ecosystem.

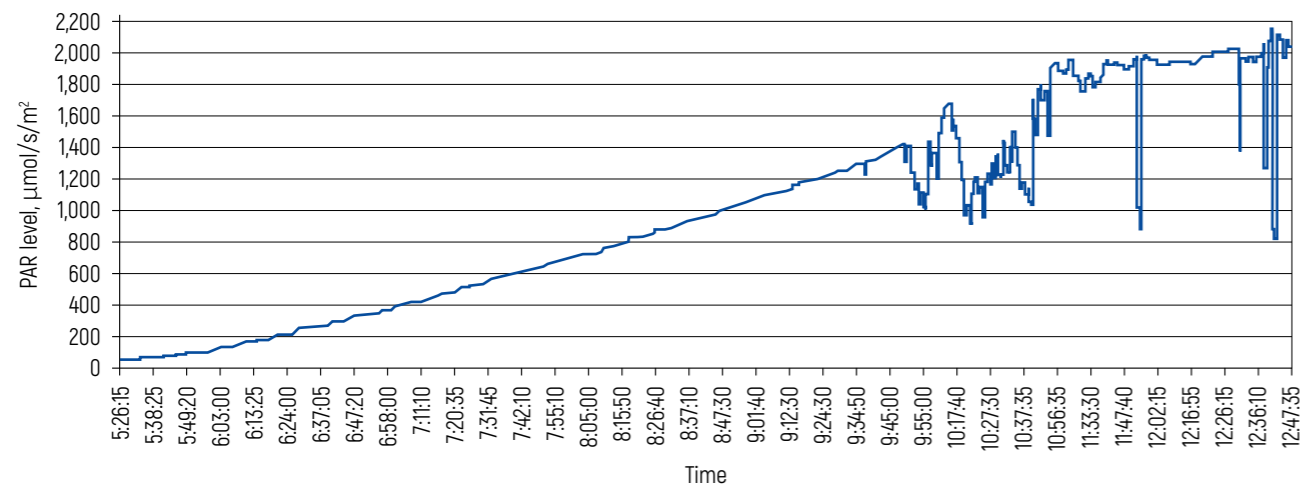

a)

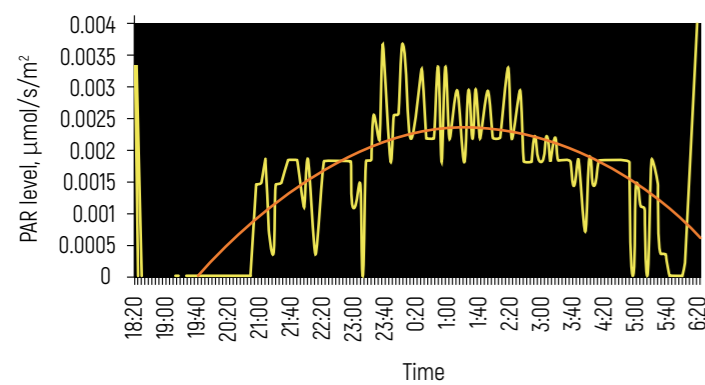

b)

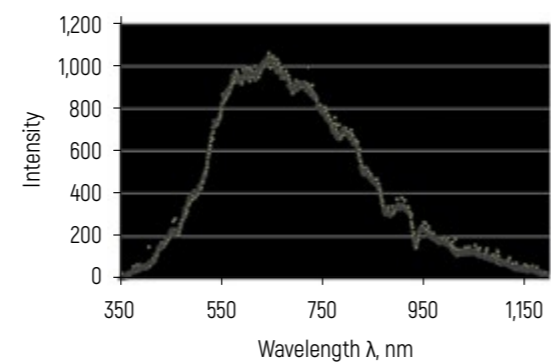

c)

Figure 5 - Photosynthetic cycles of the uBioSystem:

a - photosynthetic cycle of the Sun; b - photosynthetic cycle of the Moon; c - spectral features of moonlight

The elevation module consists of nine elements (Figure 6) creating a three-level "mountain" system. All of them are hollow but have a rigid frame made of durable metal (duralumin). At the top of each element, there are holes covered with a fine-grained mesh. Behind them, there are coolers that perform the function of creating wind to adjust temperature and humidity as well as air movement of water and pollination of vegetation. Each tier is covered with a natural mixture of clay and soil for bedding plants.

The standard operating mode of the blow-off system is as follows: the coolers of the upper module (1.8 × 0.4 × 0.4 m) function constantly, providing a quiet wind (0.2–1.5 m/s); the coolers of the middle (1.4 × 0.4 × 0.4 m) and lower (1 × 0.4 × 0.4 m) tiers are switched on as needed to adjust the thermal and hydraulic modes, pollination, lignin production to strengthen the mechanical tissues of plants (maximum blow-off is 8 m/s).

The water circulation system begins at the upper elevation module and follows along the clay channel through the small reservoirs of the middle and lower modules into the stream (Figure 7). As it descends, some of the water will irrigate nearby plants with the help of coolers. The bottom of the streambed is filled with soil for rheophyte plants and covered with a fine-grained mesh up to the mouth of the stream. The stream flows into a water body (1 × 1 × 0.55 m). The mouth of the stream is fitted out with a gentle bank (made of clay-sand mixture) to allow animals access to the water. In the lower part of the water body there is an outlet (∅ 0.05 m), through which water is supplied via a system of filter and hoses to the pump located in the zone of the elevation modules (a water hose from the lowest part of the uBioSystem is also connected to it, where water will be collected naturally) and then rises to the height of 1.8 m of the upper tier.

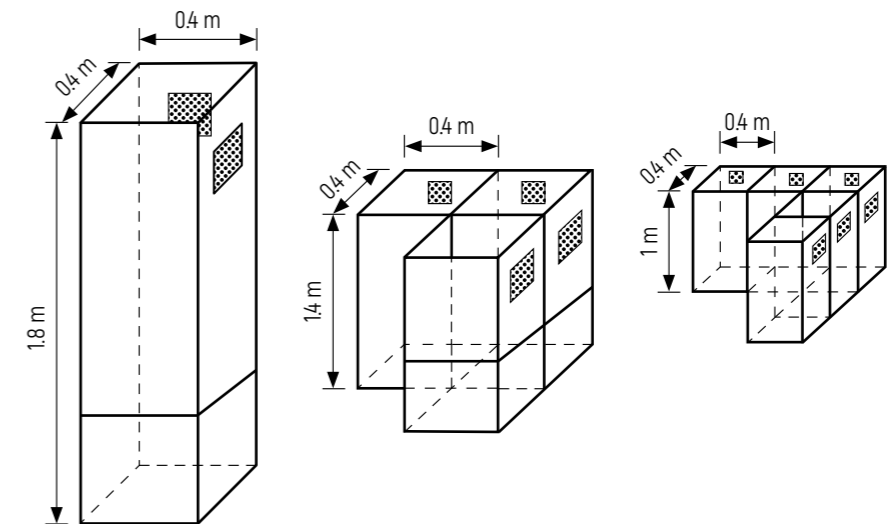

Figure 6 - Diagram of coolers in the elevation modules

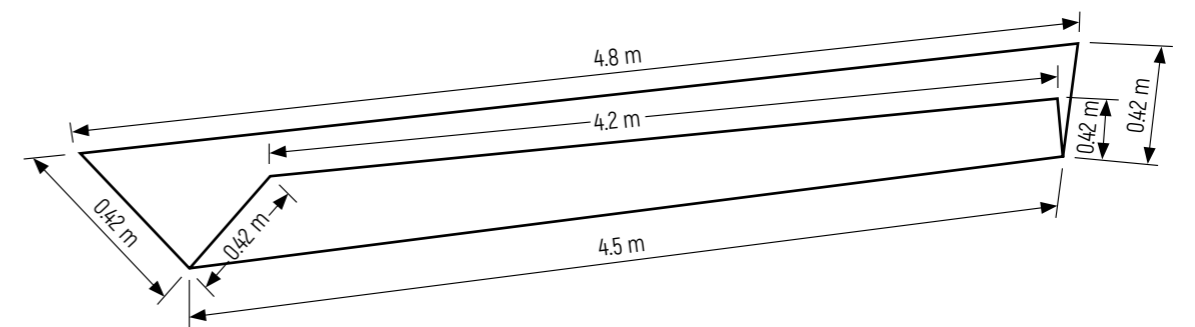

Figure 7 - Diagram of the streambed module

Sampling tubes run from the bottom of the uBioSystem and from the upper opening of the pump water hose. At this distance, the water hose is positioned as sinuous as possible to increase the water flow path through the porous filler that contains the nitrifier bacteria (for biological water purification). Given that many amphibians, reptiles and arthropods require a standing water body at certain stages of their life cycles, the uBioSystem includes a lake module. Its bottom is lined with burnt clay, on which a complex lake soil is laid out and plants are bedded.

Phytoplankton, in particular chlorella, should be present in the water systems to produce oxygen along with plants. Special baths on the second and third tiers of elevations can be made for chlorella and other oxygen producers as well as another food source for animals. The total water volume in the uBioSystem is 200 l.

The abiotic parameters in the enclosed ecosystem (air, soil and water temperature, pressure, air and soil humidity) will be monitored using a continuously operating weather station, such as the Davis 6345RU. This device (characteristics are given in Table 2), located in the uBioSystem control area, will allow to connect to itself two leaf moisture sensors, four soil moisture sensors and four temperature sensors, which can be permanently and hermetically positioned in the enclosed ecosystem area.

All uBioSystem monitoring and control elements are located in the technical area. The weather station monitors abiotic indexes in real time, recording environmental parameters (temperature, humidity, pressure, etc.) every hour, processing and analyzing the data once a week. Based on their results, the overall state of the ecosystem is assessed and, if necessary, adjustments are made (in case of excessive CO₂ the intensity of illumination is increased; in case of high humidity the temperature and air blow-off characteristics are adjusted). Illumination and wind flow are determined by the number of lamps and coolers switched on. The sprinkler/ventilation mode is manually adjusted based on the data received from the weather station.

Taking into account previous studies of the gas environment of enclosed ecosystems [15] and its relationship with heterotrophic soil inhabitants (wood lice), where large CO₂ emissions were observed during the crop growth period and the onset of stabilization only at the 10th month (Figure 8), the uBioSystem provides gas control through hermetically installed hollow tubes with a shut-off valve. The concentration of CO₂, N₂O and O₂ will be initially monitored daily until the parameters stabilize.

Table 2 – Characteristics of a continuously operating weather station

Measurement parameter	Resolution	Range	Accuracy
Soil and water temperature, °C	1	-40... -65	0.5
Soil moisture, cbar	1	0... 200	-
Atmospheric pressure, mm Hg (hPa)	0.1 (0.1)	410... 820 (540... 1,100)	0.8 (1)
Air temperature inside, °C	0.1	0... +60	0.5
Air temperature outside, °C	0.1	-40... +65	0.5
Wind cooling temperature, °C	1	-79... +57	1
Heat index, °C	1	-45... +74	1.5
Dew point temperature, °C	1	-76... +54	1.5
Relative air humidity inside, %	1	0... 90	4
Relative air humidity outside, %	1	0... 100	4
Precipitation intensity	0.2 mm	0... 2,438 mm/h	5%
Amount of precipitation	0.2 mm	0... 2,438 mm/h	3%
Wind speed, m/s (km/h)	0.5 (1.8)	1... 80 (3.6... 288)	5%
Wind direction, °	1	0... 360	3
Intensity of solar radiation, W/m ²	1	0... 1,800	5%
Density of solar energy flux, J/cm ²	0.1	0... 2,000	5%

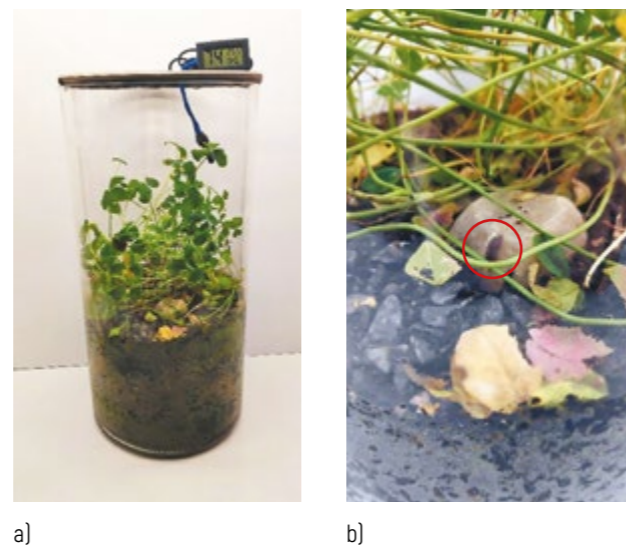

Figure 8 – Module of small enclosed ecosystem (a) and its inhabitant – a wood louse (b)

Water is sampled for analysis through a sealed tube system once a week – from the water body modules and the lower part of the uBioSystem water drain; soil samples are taken monthly.

Conclusion

At present, the Earth's biosphere is under increasing anthropogenic pressure. In order to maintain a balance in the relationships between humanity and its habitat, a deep understanding of natural processes is required. This knowledge can be acquired through small-scale ecosystem models with enclosed cycles of matter, energy and information.

The proposed uBioSystem project pays special attention to soil, its structure and trophic web. The described modules and devices will make it possible to control and, if necessary, correct all the factors inherent in natural ecosystems allowing to arrange long-term studies of living organisms inhabiting the uBioSystem.

References

1. Chikunova, V.V. Defitsit vodnykh resursov kak global'naya ekologicheskaya problema [Shortage of Water Resources as a Global Environmental Problem] / V.V. Chikunova, N.I. Stuzhenko // Vodnyye resursy – osnova global'nykh i regional'nykh proyektov obustroystva Rossii, Sibiri i Arktiki v XXI veke: Materials of the National Scientific and Practical Conference with International Participation, Tyumen, Mar. 17–18, 2022: Collection of Articles: in 2 vol. / ed. L.V. Belova. – Tyumen: Tyumenskiy industrial'nyy universitet, 2022. – Vol. 1. – P. 93–96.
2. Slinchak, A.I. Priznaki global'nogo ekologicheskogo krizisa v Rossii: riski, ugrozy, veroyatnyye posledstviya [Signs of Global Environmental Crisis in Russia: Risks, Threats, Likely Consequences] / A.I. Slinchak // Problemy ustoychivosti ekologo-khozyaystvennykh i sotsial'no-kul'turnykh sistem transgranichnykh regionov: Materials of the International Scientific and Practical Conference, Pskov, Nov. 20–21, 2014. – Pskov: LOGOS Plyus, 2014. – P. 226–234.
3. Myaskov, A.V. Ekologo-ekonomicheskiye prichiny sokrashcheniya bioraznoobraziya [Ecological and Economic Causes of Biodiversity Decline] / A.V. Myaskov, N.V. Lukyanova // Gornyy informatsionno-analiticheskiy byulleten'. – 2005. – No. 7. – P. 186–191.

4. Unitsky, A. EcoCosmoHouse as a Space for the Conservation of Species Diversity of Tropical and Subtropical Flora / A. Unitsky, V. Pavlovsky, D. Feofanov // Non-Rocket Space Industrialization: Problems, Ideas, Projects: Collection of Articles of the II International Scientific and Technical Conference, Maryina Gorka, Jun. 21, 2019 / Astroengineering Technologies LLC; ed. A. Unitsky. – Minsk: Paradox, 2019. – P. 153–157.
5. Berg, M.P. Temporal and Spatial Variability in Soil Food Web Structure / M.P. Berg, J. Bengtsson // Oikos. – 2007. – Vol. 116, No. 11. – P. 1789–1804.
6. Adding to 'the Enigma of Soil Animal Diversity': Fungal Feeders and Saprophagous Soil Invertebrates Prefer Similar Food Substrates / M. Maraun [et al.] // European Journal of Soil Biology. – 2003. – Vol. 39, iss. 2. – P. 85–95.
7. Curry, J.P. Factors Affecting the Abundance of Earthworms in Soils / J.P. Curry // Earthworm Ecology / ed. C.A. Edwards. – 2nd ed. – Boca Raton: CRC Press, 2004. – P. 91–113.
8. Nikolayeva, T.G. Sokhraneniye bioraznoobraziya i pochvennogo plodorodiya – osnova ustoychivogo razvitiya organicheskogo sel'skogo khozyaystva [Conservation of Biodiversity and Soil Fertility Is the Basis for Sustainable Development of Organic Agriculture] / T.G. Nikolayeva, B.R. Grigoryan, L.M. Sungatullina // Uchonyye zapiski Kazanskogo universiteta. – 2011. – Vol. 153, bk. 1. – P. 136–151.
9. Agroekologiya [Agroecology]: Textbook / V.A. Chernikov [et al.]; ed. V.A. Chernikov, A.I. Chekeres. – Moscow: Kolos, 2000. – 536 p.
10. Fertility and Physico-Chemical Indicators of Light "Space" Potting Soils for EcoCosmoHouse / A. Unitsky [et al.] // Non-Rocket Near Space Industrialization: Problems, Ideas, Projects: Collection of Articles of the IV International Scientific and Technical Conference, Maryina Gorka, Sep. 18, 2021 / Astroengineering Technologies LLC, Unitsky String Technologies Inc.; ed. A. Unitsky. – Minsk: StroyMediaProject, 2022. – P. 309–324.
11. Marchenko, M.V. Sravnitel'noye issledovaniye ognepornykh svoystv dolomita s ispol'zovaniyem gliny v kachestve dobavok [Comparative Study of Refractory Properties of Dolomite Using Clay as Additives] / M.V. Marchenko, D.A. Kozlov // Obrazovaniye. Nauka. Proizvodstvo: XIII International Youth Forum, Belgorod, Oct. 8–9, 2021: Collection of Proceedings of the Conference. – Belgorod: BGTU im. V.G. Shukhova, 2021. – P. 1857–1861.

12. Borovskikh, I.V. *Optimizatsiya granulometricheskogo so-stava peska dlya polucheniya vysokoprochnogo tonko-zernistogo betona [Optimization of Granulometric Com-position of Sand to Produce High-Strength Fine-Grained Concrete]* / I.V. Borovskikh, N.M. Morozov, V.G. Khozin // *Izvestiya KazGASU.* – 2008. – No. 2 (10). – P. 121–124.
13. Alekseyev, V.M. *Fiziko-mekhanicheskiye svoystva grun-tov i laboratornyye metody ikh opredeleniya [Physical-Mechanical Properties of Soils and Laboratory Meth-ods of Their Determination]: Textbook* // V.M. Alekseyev, P.I. Kalugin. – Voronezh: VGASU, 2009. – 88 p.
14. *Determination of Key Parameters of Service Lighting for Plants / A. Unitsky [et al.] // Non-Rocket Near Space Industrialization: Problems, Ideas, Projects: Collection of Articles of the V International Scientific and Technical Conference, Maryina Gorka, Sep. 23–24, 2022 / Astroengineering Technologies LLC, Unitsky String Technologies Inc.; ed. A. Unitsky. – Minsk: StroyMediaProject, 2023. – P. 170–177.*
15. *Quantitative Assessment of Carbon Balance of Autotro-phic and Heterotrophic Communities in the Enclosed Eco-system Prototype / A. Pauliuchenka [et al.] // Non-Rocket Near Space Industrialization: Problems, Ideas, Projects: Collection of Articles of the V International Scientific and Technical Conference, Maryina Gorka, Sep. 23–24, 2022 / Astroengineering Technologies LLC, Unitsky String Technologies Inc.; ed. A. Unitsky. – Minsk: StroyMediaProject, 2023. – P. 232–239.*





UDC 58.018:58.04

Use of Elicitors to Improve the Adaptability of Plants Under the EcoCosmoHouse Conditions

Y. Krukau

V. Zayats

I. Naletov

Unitsky String Technologies Inc.,
Minsk, Belarus



There is a review of the influence of elicitor, obtained from reishi mushroom (*Ganoderma lucidum* (Curt.)) and used in concentrations of 1×10^{-3} , 2×10^{-3} and 3×10^{-3} ml/l, on the growth and development of tomato (*Solanum lycopersicum* L.) and vegetable pepper (*Capsicum annuum* L.). Elicitor was introduced into the substrate by irrigating experimental vegetables every two weeks. During the plants growing observation of their morphological structure was performed, as well as their height and the duration of the period before the flowering phase were measured and assessed.

Keywords:

adaptation of plants, EcoCosmoHouse (ECH), elicitors, growth promoters, reishi mushroom (*Ganoderma lucidum* (Curt.)), tomato (*Solanum lycopersicum* L.), vegetable pepper (*Capsicum annuum* L.).

Introduction

Plants in an enclosed ecosystem can face many unfavorable factors, such as limited access to light and water, high level of pathogen load, increased risk of infestation, salinization, if improper cultivation or temporary equipment failure occur. During a prolonged drought, crops experience stress resulting in reduced yields.

It is known that the use of exogenous elicitors leads to a decrease in various undesirable reactions of plants to any unfavorable impact, which, in turn, has a positive effect on the amount of products obtained. Increasing stress resistance of organisms in enclosed ecosystems (for example, in the EcoCosmoHouse (ECH)) is required to create a comfortable and safe environment that provides ECH residents with everything they need for the longest possible time.

Elicitors are substances of biogenic and abiogenic origin that induce resistance and generate multiple protective responses to adverse impacts [1]; make a significant contribution to plant survival and adaptability by helping to establish chemical and physical barriers and mechanisms [2, 3]. In addition, they contribute to the efficient use of resources and the acquisition of a significant amount of nutrients from the environment. According to scientific studies, biogenic elicitors include proteins [4], glycoproteins,

oligosaccharides [5] and lipids. These substances can be applied both for seed and soil treatment and for leaf or root feeding. Some elicitors have hormones that stimulate crop growth and improve their physiological condition [6]. They also contain nutrients (amino acids and vitamins) that have a positive effect on plants. Stable growth and higher yields can be achieved with proper use of elicitors.

Elicitors are substances of both biogenic and abiogenic origin. Biogenic elicitors include metabolic products and fragments of cell walls of insects, pathogenic and non-pathogenic microorganisms and plants. Abiogenic elicitors assume various spectra of effects: physical (ultraviolet rays, magnetic fields, radiation, etc.) or chemical (e.g., the effect of heavy metal oxides).

Biogenic elicitors include conserved molecular ligands of nonspecific elicitors (MAMPs), which are characteristic of pathogens but absent in the plant cell. They are recognized by it as foreign and induce initiation of a primary immune response (PTI) not only in crops exposed to this pathogen but also in many other types of plants. Transmembrane pattern recognition receptors (PRRs) are responsible for triggering nonspecific mechanisms of physiological response. The interaction of plant PRRs with fungal MAMPs (various proteins, xylanase, N-acetyl-D-glucosamine polymer, etc.) leads to PTI activation (Figure 1).

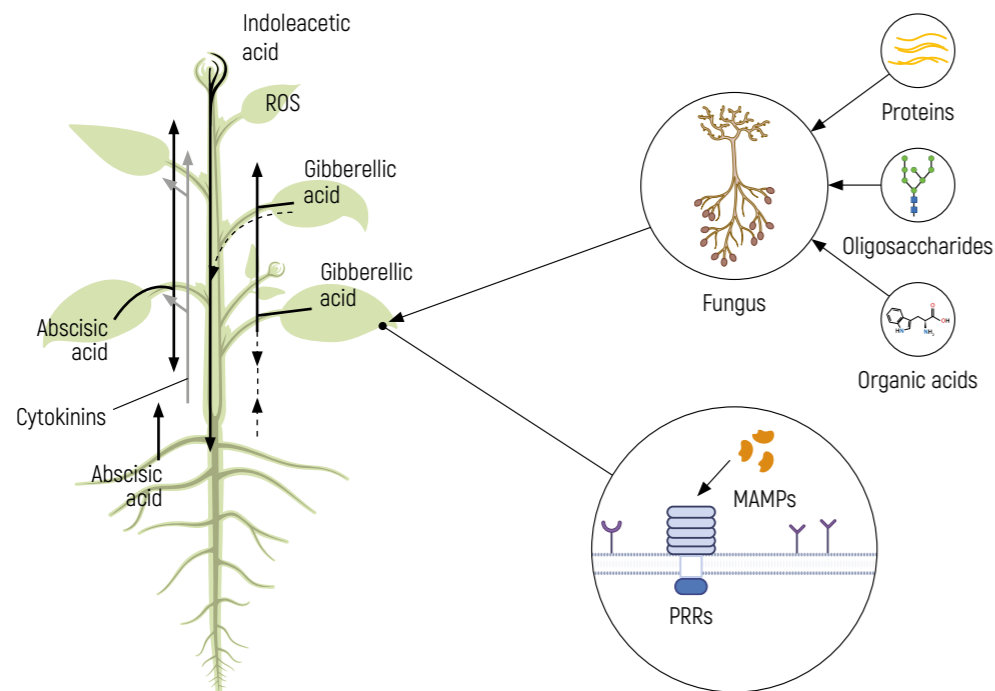

Figure 1 – General diagram of interaction between plant PRRs and fungal MAMPs. PTI activation

In response to contact with MAMPs, there occurs an increase in the concentration of Ca^{2+} ions as well as the release of reactive oxygen species (ROS), nitrogen and the production of phytoalexins. In addition, transcription factors are activated, the production of chitinase, glucanase, ethylene, jasmonic and salicylic acids is observed as well as the formation of auxin, cytokinin and gibberellic forms [7].

The evolutionary development of pathogens has allowed them to generate tactics to bypass PTI protection. This effect is achieved by appearance of mutations in genes that provide pathogens with unrecognizability of PRRs or by inhibition of receptor activity. The second blockade of crop protection, formed during coevolution with pathogens, is a specific immunity (ETI) caused by the interaction of R-genes (plant genes) with the effectors of Avr-genes (pathogen genes) [8, 9]. The result of R/Avr-interaction is a hypersensitivity reaction, which in most cases leads to the production of phytoalexins by cells, resulting in the death of infected cells (Figure 2).

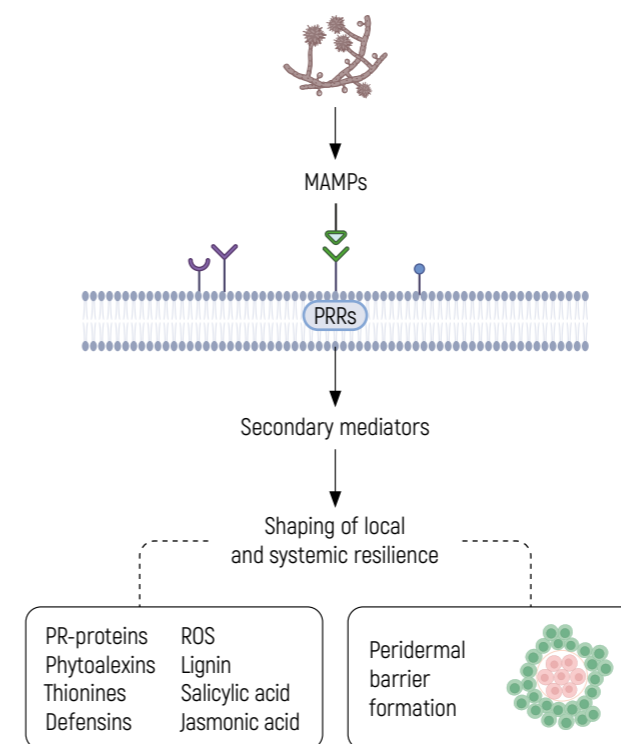

Figure 2 – Simplified diagram of the hypersensitivity reaction process

Cell death is accompanied by rapid formation of a periderm barrier, which suppresses the growth and development of parasitic organisms and stops their spread [10, 11].

The processes induced by PTI and ETI differ in the concentration of synthesized hormones, the rate of immune response and signaling pathways. The final result of ETI is the selection of highly specific R-proteins that rapidly suppress disease development [12, 13].

The Biotechnology Department of Unitsky String Technologies Inc. (Minsk, Belarus) carried out works on studying the elicitor action of preparations created on the basis of saprophytic fungus – reishi mushroom (*Ganoderma lucidum* (Curt.)). Its extract was obtained by extraction with alkali solution under heating. It was then purified and diluted with water to form a 0.1 % working solution.

The aim of the study was to analyze the effect of this preparation on the formation of systemic resistance to pathogens in vegetable pepper (*Capsicum annuum* L.) and tomato (*Solanum lycopersicum* L.) based on their economic value and daily use in human nutrition.

Study Materials and Course of Work

Leaves of 14-day-old plants, in which the leaf plate had already reached its final growth, were used as the object of study, and biochemical parameters allowed us to review the processes necessary for the experiment.

Seeds were sown in cassettes filled with multipurpose potting soil, in which the experimental samples were grown to the branching stage (height of 5–7 cm). Already shaped young pepper and tomato plants were transferred to separate containers.

Based on research results [10, 13], three different concentrations of elicitor (1×10^{-3} , 2×10^{-3} , 3×10^{-3} ml/l) were used in the experiment and applied to the substrate by irrigation once every two weeks (Figure 3).

Exogenous elicitor obtained by extraction from reishi mushroom was as the active ingredient.

The plants were then transferred to a growth chamber with the following climatic parameters: 25 °C temperature, 6,000 lux light intensity and a 14-hour photoperiod. Nutrient medium was added as needed in all variants of the experiment. The height of the experimental samples was measured for 40 days.

In addition, resistance of plants to diseases caused by imperfect fungi was tested: in tomato – to alternariose and phomosis, in pepper – to anthracnose and cercosporiosis. Infection was carried out by spraying healthy crops with an aqueous fungal extract obtained by washing off from infected plants.

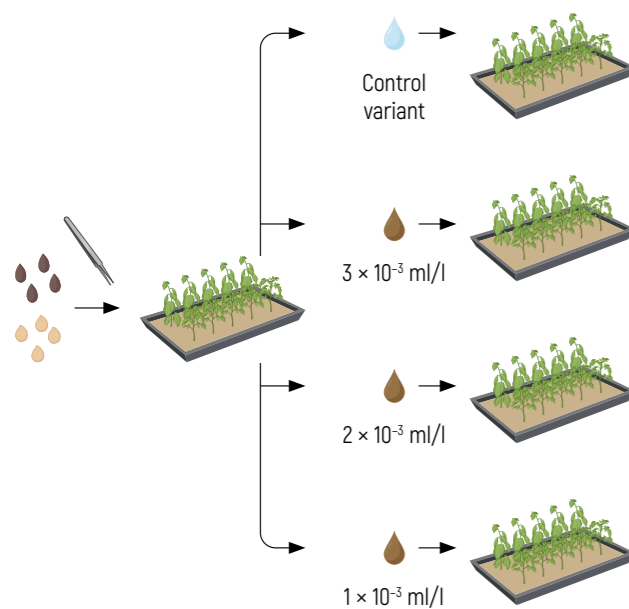

Figure 3 – Diagram of setting up the experiment on the effect of elicitor in different concentrations on growth and physiological parameters of plants cultivated on a solid substrate

Research Results

Tomato (*Solanum lycopersicum* L.)

Table 1 presents the results of measuring the height of two samples during the first 40 days of growth of tomato cultivated on solid substrate under the effect of fungal elicitor. The studies were conducted until the flowering phase.

According to [10], the elicitor under consideration is a growth stimulant, and the main parameter of its effectiveness is the growth rate. When the elicitor was used at a concentration of 3×10^{-3} ml/l, an average growth rate of 2.05 cm/day was recorded, which is 11.8 % higher than the control index; for a concentration of 2×10^{-3} ml/l, it was 1.87 cm/day (2 % higher); for a concentration of 1×10^{-3} ml/l, it was 1.96 cm/day (7 % higher).

The greatest influence on the final growth rate was exerted by the concentration of 3×10^{-3} ml/l, at which the average growth rate was 6 % higher in relation to the control variant (Figure 4). At the same time, increased growth induction at the initial periods of plant development was observed when an elicitor was added (Figure 5). The maximum growth rate was recorded at a concentration of 3×10^{-3} ml/l in the middle of vegetation (2.8 cm/day). This change may be related to the increase under the effect of the applied compounds of synthesis of primary and secondary metabolites.

Table 1 – Growth of tomato cultivated on solid substrate under the effect of fungal elicitor

Object of measurement	Growth, %
Control variant	
Sample No. 1	1,415.38
Sample No. 2	1,175
Average index	1,295.19
3×10^{-3} ml/l	
Sample No. 1	1,088.89
Sample No. 2	1,583.33
Average index	1,336.11
2×10^{-3} ml/l	
Sample No. 1	1,314.29
Sample No. 2	1,000
Average index	1,157.15
1×10^{-3} ml/l	
Sample No. 1	1,077.78
Sample No. 2	1,450
Average index	1,263.89

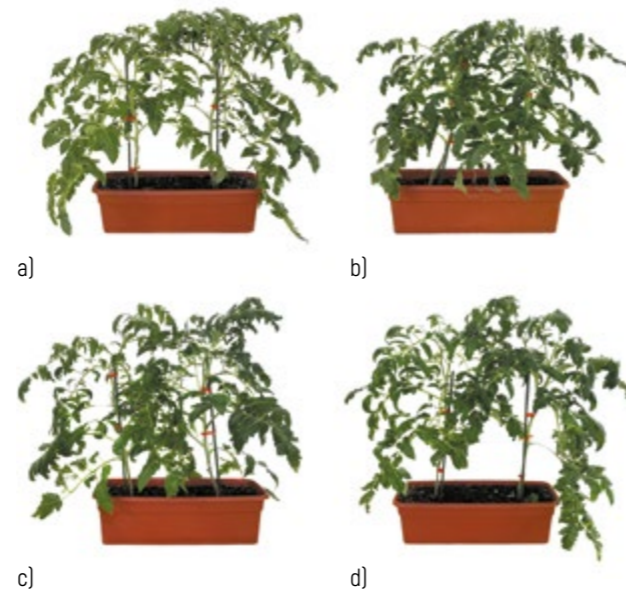

Figure 4 – Tomato grown on solid medium with the addition of fungal elicitor:
a – control variant; b – at a concentration of 3×10^{-3} ml/l;
c – at a concentration of 2×10^{-3} ml/l;
d – at a concentration of 1×10^{-3} ml/l

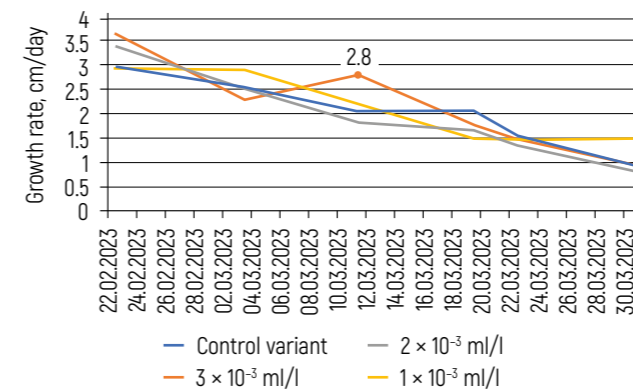

Figure 5 – Diagram of tomato growth rate under the effect of fungal elicitor, used in three concentrations, compared to the control variant

The first flowering of tomato occurred on the 40th day after planting. The number of flowers averaged 5–8 pcs.

The plants successfully formed ovary under the effect of the fungal elicitor at concentrations of 1×10^{-3} ml/l and 2×10^{-3} ml/l. Tomato flowers in these variants possessed increased mechanical tissue, which contributes to better fruiting and reduces the risk of fruit falling-off before maturity. Increased concentration did not result in increased mechanical tissue in fruit stalks (pedicels).

Under induced infection of tomato with an aqueous extract of alternariose and phomosis pathogens, the control variant was exposed to the greatest impact of fungi, which was expressed in extensive leaf spotting and further increase in the diameter of spots. The plants treated with elicitor at concentrations of 2×10^{-3} ml/l and 1×10^{-3} ml/l showed less manifestation of pathogen load. Spotting appeared to be localized, not spreading throughout the whole sample, and spots that had already occurred did not expand. When the preparation was used at a concentration of 3×10^{-3} ml/l, no infestation was observed, indicating a more complete induction of the protective genetic potential of the plants.

Vegetable Pepper (*Capsicum annum* L.)

Table 2 shows the results of height measurements of two vegetable pepper samples cultivated on solid substrate under the effect of fungal elicitor, during 40 days before the flowering phase.

The highest index of average growth (600 %) during the whole growing season was observed when the fungal elicitor was used at a concentration of 3×10^{-3} ml/l. The growth rate per day was also recorded for a comprehensive assessment (Figure 6).

Table 2 – Growth of vegetable pepper cultivated on solid substrate under the effect of fungal elicitor

Object of measurement	Growth, %
Control variant	
Sample No. 1	557.14
Sample No. 2	616.67
Average index	586.91
3×10^{-3} ml/l	
Sample No. 1	550
Sample No. 2	650
Average index	600
2×10^{-3} ml/l	
Sample No. 1	650
Sample No. 2	542.86
Average index	596.43
1×10^{-3} ml/l	
Sample No. 1	542.86
Sample No. 2	608.33
Average index	575.6

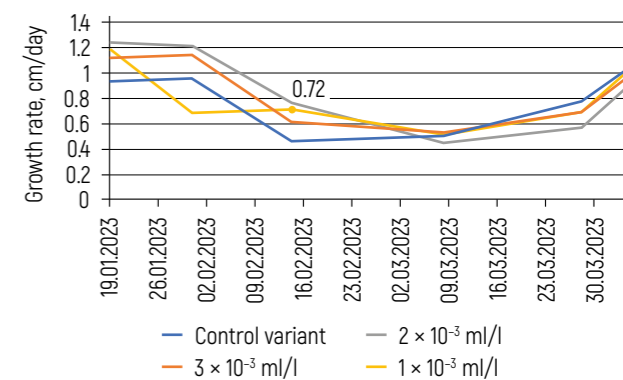

Figure 6 – Diagram of vegetable pepper growth rate under the effect of the elicitor, used in three concentrations, compared to the control variant

The growth rate on the 40th day of the experiment in the variant with the use of elicitor at a concentration of 3×10^{-3} ml/l was 1.13 cm/day, which is 19.8 % more than that of the control value; for the concentration of 2×10^{-3} ml/l – 1.23 cm/day (increase by 27.4 %); for the concentration of 1×10^{-3} ml/l the highest value was observed on 12.02.2023

and amounted to 0.72 cm/day, which is 55 % more compared to the control variant [Figure 6]. The most significant increase was due to activation of genes of synthesis of primary and secondary metabolites in response to the elicitor action. On the 68th day, the experimental vegetable pepper samples reached the size of their physiological varietal maximum at about the same level (Figure 7).

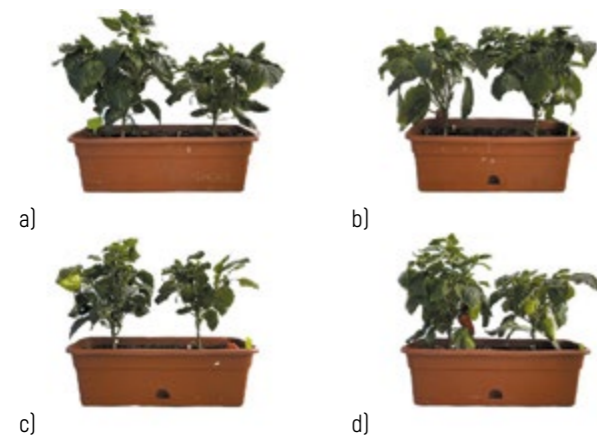

Figure 7 – Pepper grown on solid medium with the addition of fungal elicitor:

- a – control variant; b – at a concentration of 3×10^{-3} ml/l;
c – at a concentration of 2×10^{-3} ml/l;
d – at a concentration of 1×10^{-3} ml/l

Thus, the average growth rate in the variant with a concentration of 1×10^{-3} ml/l is by 3.3 % higher compared to the control sample, at a concentration of 2×10^{-3} ml/l – by 10.3 %, at a concentration of 3×10^{-3} ml/l – by 8.6 %.

The appearance of buds was observed on all variants of vegetable pepper in 25–27 days after transplanting into the experimental containers. Flowering occurred irregularly, on the 20th–22nd day after bud emergence. The number of flowers varied from 30 (at a concentration of 3×10^{-3} ml/l) to 56 pcs (at a concentration of 1×10^{-3} ml/l).

Each plant has successfully formed one or two ovaries. The highest number of ovaries (6 pcs) was observed at a concentration of 1×10^{-3} ml/l.

If we assess the ability to resist fungal infections (anthracnose and cercosporosis), a reduction in fungal infection centers (by 10–15 %) was observed at all concentrations of elicitor compared to the control variant.

Based on the achieved results, it can be judged about the increase in daily growth of plants treated with elicitor obtained from the reishi mushroom. It can also be assumed

about the positive effect of the fungal elicitor on the formation of ovaries in vegetable pepper.

Conclusion

In response to the introduction of fungal elicitor, tomato and vegetable pepper trigger defense mechanisms that provoke the synthesis of gibberellic forms of phytohormone, as evidenced by the partial early flowering observed in different variants of the experiment in relation to the control sample. This, in turn, can lead to a 15 % reduction in fruit ripening time.

The elicitor obtained from reishi mushroom protects the tomato from alternariose and phomosis. Thus, during the experiment, control plants were affected by phomosis fungi, which led to wilting of leaves and appearance of spots on them; during an induced infection in variants with the use of elicitor in various concentrations, phomosis did not develop, the same effect was observed in the case of alternariose infection. Therefore, the extracted fungal elicitor can be considered as a means of biological protection against a pathogenic load of phomosis and alternariose on tomato as well as anthracnose and cercosporosis on pepper.

The use of the studied concentrations of fungal elicitor increased the daily crop growth compared to the control variant.

The data obtained are explained by the fact that nonspecific elicitors may play a leading role in the induction of the immune potential. As a result of possible formation of ethylene, jasmonic and salicylic acids as well as auxin, cytokinin and gibberellic forms in response to interaction with the elicitor, the plant is given a stimulus to resist unfavorable factors at the expense of its natural gene potential.

In the work to follow, it is planned to analyze the quality of fruits (including checking the concentration of nitrates) as well as to identify their size, weight of 1,000 seeds; to study the content of dry matter, water-soluble carbohydrates, vitamin C in the harvested crop. This is a minimum set of actions that helps to assess the quality of products. At the same time, it is necessary to determine the viability of seeds and consider the induction of immunity of tomato and vegetable pepper under the effect of elicitors.

Elicitors can be actively used in an enclosed ecosystem to stimulate the growth and development of crops as well as for protection against fungal affections. The elicitor extracted from the reishi mushroom can be obtained under the ECH conditions by cultivation of this fungus on secondary plant substrates [12].

References

1. Baranova, Ye.N. *Problemy i perspektivy genno-inzhenernogo podkhoda v reshenii voprosov ustoychivosti rasteniy k zasoleniyu (obzor) [Problems and Perspectives of Genetic Engineering Approach to the Resolving of the Tasks of Plant Resistance to Salinity (Review)]* / Ye.N. Baranova, A.A. Gulevich // *Sel'skokhozyaystvennaya biologiya*. – 2006. – No. 1. – P. 39–56.
2. Belova, T.A. *Fiziologicheskiye osnovy adaptatsii rasteniy k vozdeystviyu solevogo stressa [Physiological Bases of Plant Adaptation to the Effects of Salt Stress]* / T.A. Belova, A.S. Kravchenko // *Auditorium*. – 2018. – No. 1 (17). – P. 42–48.
3. Polevoy, V.V. *Fiziologiya rasteniy [Plant Physiology]: Textbook for Biology Specialties of Universities* / V.V. Polevoy. – Moscow: Vysshaya shkola, 1989. – 464 p.
4. Nürnbergger, T. *Fungal Peptide Elicitors: Signals Mediating Pathogen Recognition in Plants* / T. Nürnbergger, D. Nennstiel // *Zeitschrift für Naturforschung C*. – 1998. – Vol. 53, iss. 3–4. – P. 141–150.
5. *The Regulatory Mechanism of Fungal Elicitor-Induced Secondary Metabolite Biosynthesis in Medical Plants* / X. Zhai [et al.] // *Critical Reviews in Microbiology*. – 2017. – Vol. 43, iss. 2. – P. 238–261.
6. Dyakov, Yu.T. *Gribnyye elisitory [Fungal Elicitors]* / Yu.T. Dyakov // *Bioticheskiye svyazi gribov: mostly mezhdru tsarstvam: Materials of the VII All-Russian Mycological School-Conference with International Participation, Moscow, Aug. 2–8, 2015 / Lomonosov Moscow State University, Skadovsky Zvenigorod Biological Station*. – Moscow: ZBS MGU, 2015. – P. 18–38.
7. Gómez-Gómez, L. *FLS2: An LRR Receptor-Like Kinase Involved in the Perception of the Bacterial Elicitor Flagellin in Arabidopsis* / L. Gómez-Gómez, T. Boller // *Molecular Cell*. – 2000. – Vol. 5, iss. 6. – P. 1003–1011.
8. *Regulation and Role of Fungal Secondary Metabolites* / J. Macheleidt [et al.] // *Annual Review of Genetics*. – 2016. – Vol. 50. – P. 371–392.
9. Patkar, R.N. *Fungal Manipulation of Hormone-Regulated Plant Defense* / R.N. Patkar, N.I. Naqvi // *PLOS Pathogens*. – 2017. – Vol. 13, No. 6. – 1006334.
10. Zayats, V.S. *Protektornaya sposobnost' ekzogennykh elisitorov iz Ganoderma lucidum pri induksii solevogo stressa u kress-salata [Protective Ability of Exogenous Elicitors from Ganoderma lucidum in the Induction of Salt Stress in Garden Cress]* / V.S. Zayats, I.V. Naletov, Ye.A. Kryukov // *Nastoyashcheye i budushcheye biotekhnologii rasteniy: Materials of the International Scientific Conference, Minsk, May 24–26, 2023 / National Academy of Sciences of Belarus, Central Botanical Garden, Council of Botanical Gardens of CIS Countries Under IAAS; ed. by V.N. Reshetnikov [et al.]*. – Minsk: IVTS Minfina, 2023. – P. 75.
11. *Assotsiatsiya agronomicheskii tsennyykh mikroorganizmov dlya uluchsheniya plodorodiy zemel' [Association of Agronomically Valuable Microorganisms for Improving Land Fertility]* / V.S. Zayats [et al.] // *Mikrobye biotekhnologii: fundamental'nyye i prikladnyye aspekty: Materials of the XIII International Conference, Minsk, Jun. 6–9, 2023 / National Academy of Sciences of Belarus*. – Minsk: Bielaruskaja navuka, 2023. – P. 266–267.
12. Buglak, P. *Growing Mycelium of Basidiomycetes in Organic Substrates in an Enclosed Ecosystem* / P. Buglak, V. Zayats, I. Naletov // *Non-Rocket Near Space Industrialization: Problems, Ideas, Projects: Collection of Articles of the V International Scientific and Technical Conference, Maryina Gorka, Sep. 23–24, 2022 / Astroengineering Technologies LLC, Unitsky String Technologies Inc., ed. A. Unitsky*. – Minsk: SroyMediaProject, 2023. – P. 240–246.
13. Patel, H. *Elicitors in Plant Tissue Culture* / H. Patel, R. Krishnamurthy // *Journal of Pharmacognosy and Phytochemistry*. – 2013. – Vol. 2, iss. 2. – P. 60–65.



UDC 579.64

Biorecycling of Organic Residues with the Help of Microorganisms

A. Unitsky^{1,2}
Dr. of Philosophy
in Information Technologies
(Transport)

T. Pyatakova²

K. Boyko²

I. Naletov²

¹ Astroengineering Technologies LLC,
Minsk, Belarus

² Unitsky String Technologies Inc.,
Minsk, Belarus



The results of an experiment on the biorecycling of organic waste by microorganisms (bacteria) are presented to significantly facilitate the processing of organic garbage in the conditions of the enclosed ecosystem - EcoCosmoHouse (ECH). Laboratory tests made it possible to select agronomically valuable microorganisms with which the biorecycling process was carried out. The experience of using biorecycled residues (liquid compost) as an organic fertilizer for plants is described.

Keywords:

biorecycling, EcoCosmoHouse (ECH), enclosed ecosystem, microorganisms, waste.

Introduction

Nowadays the issue of organic waste utilization is acute in many countries of the world, and its improper handling poses a danger to nature and human health. Some countries are just beginning to master the recycling of garbage (including solid domestic waste), while others have already made a significant progress in this field and try to use every type of it [1]. However, even with a successfully functioning utilization system, the problem remains unsolved.

According to the UN data, the population of planet Earth has grown from 7 to 8 bln over the past 12 years, which exceeds the index of the middle of the 20th century by more than three times [2]. Accordingly, the consumption of resources has increased. The volume of solid municipal waste (SMW) in the Republic of Belarus is approaching 4 mln tons per year, with only 25 % being separately collected and recycled [3]. The remaining part is sent to waste landfills for burial, which negatively affects the environmental situation [4]. Waste pollutes water bodies, reduces soil fertility and accumulates in large quantities in the environment. Its volume grows every year, it begins to occupy vast areas and absorbs more and more land suitable for life. In the period from 2022 to 2025 in Belarus it is planned to build waste landfills in Minsk as well as in Baranovich, Brest, Pinsk, Kobrin, Orsha, Polotsk, Gomel, Volkovysk, Lida, Borisov, Minsk, Soligorsk, Pukhovichy, Mogilev and Bobruisk districts. Currently, there is one waste landfill in the capital city – Trostenets, the area of which is 30 ha, and the depth of the excavation pit is 11 m [5]. When recycling these waste, it is possible to return all the elements and compounds available in them to the soil, increasing its humus content and making it more suitable for subsequent cultivation of organic food products. Thus, there is a need to find environmentally friendly and safe methods of utilization [6].

The SMW can contain up to 40 % of organic matter [7]. One of the methods used for its recycling is composting. However, it has a serious disadvantage – a significant duration of the process (from four to six months). On average, food waste takes about one month to decompose, but, for example, orange peels take six months, and an apple stump takes two months. An alternative way of recycling is biorecycling. Its mechanism is similar to composting, but all processes are significantly intensified by the use of microbiological inoculants. This method is the safest, biologically clean and the least durable [8].

This article considers the results of organic waste biorecycling with the help of associations of microorganisms. At the same time, the potential of using the resulting liquid

compost as an environmentally friendly fertilizer in an enclosed system of the EcoCosmoHouse (ECH) has been studied [9].

Experimental Part

From a microbiological point of view, composting is an exothermic process of biological oxidation in which an organic substrate undergoes aerobic biodegradation by an association of microorganisms under the conditions of increased temperature and humidity. The microflora not only determines the rate of compost maturation and quality but also has an impact on the environment when the microorganisms subsequently enter the soil.

During the composting process, organic substances such as protein, peptides, amino acids, ammonium compounds, carbohydrates, simple sugars, organic acids and others are oxidized by oxygen in the biomass. In addition, new organic substances are created accompanying the production of water, carbon dioxide, ammonia and unpleasantly smelling gases with the release of heat. So, food waste can be used as useful organic fertilizers due to the content of mineral components in the cells, including macro-, micro- and ultramicroelements necessary for the nutrition of living organisms.

Various food waste generated at Farmstead LLC (Maryina Gorka, Belarus) were used as organic matter in the experiment (Table 1).

Food waste are essentially fats, proteins and carbohydrates. On this basis, the selection of microorganisms was based on the principle of compatibility and complementarity.

Table 1 – Composition of food waste

Component	Composition, %
Potatoes (including peels)	60
Vegetable waste	15
Fruit waste	5
Meat waste	3
Fish waste	2
Bones	4
Bread	2
Dairy products	1
Eggshells	1
Foreign admixtures	4
Miscellaneous waste	3

To obtain cell suspension (hereinafter referred to as inoculum), agronomically valuable microorganisms (cellulolytic and nitrogen-fixing) were used: *Bacillus amyloliquefaciens* BIM B-1236, *Aeromonas* sp., *Citrobacter* spp., *Paenibacillus* sp., *Azotobacter vinelandii* BIM B-75, separated by the biotechnology department of Unitsky String Technologies Inc. (Minsk, Belarus) from the world Bank of fertile soils and soil microorganisms (created in Belarus on the territory of the Unitsky's Farm Enterprise) and possessing a complex of useful properties [10].

At the first stage of the experiment, an inoculum consisting only of cellulolytic microorganisms (*Bacillus amyloliquefaciens* BIM B-1236, *Aeromonas* sp., *Citrobacter* spp., *Paenibacillus* sp.), in volumes of 50, 100, 150, 200 ml and 1 l (hereafter referred to as control) was added to food waste weighing 100 g and left for seven days in a thermostat at the temperature of (32.5 ± 2) °C until complete decomposition.

At the second stage (on the seventh day), nitrogen-fixing cultures (*Azotobacter vinelandii* BIM B-75) were added to the compost obtained by decomposition and left for another three days. The results were recorded on the seventh and tenth day of the experiment. Nitrogen content and total microbial count (TMC) were considered.

At the third stage, the obtained liquid compost was used as an organic additional feed for lettuce (*Lactuca sativa* L.). Compost from each of the inoculum volumes (50, 100, 150, 200 ml and control) was added to the substrate intended for seed planting (Table 2), and a mineral fertilizer with nitrogen, phosphorus and potassium (hereinafter referred to as NPK) was added.

Table 2 – Reference designations of soil compositions used in the experiment setup

Ratio of compost to substrate	Inoculum volume, ml	Designation
1 : 20	50	Variant 1
	100	Variant 3
	150	Variant 5
	200	Variant 7
1 : 50	50	Variant 2
	100	Variant 4
	150	Variant 6
	200	Variant 8

Main Results of the Experiment

On the second day after setting up the first stage of the experiment, a significant fermentation and gas production was observed in the samples compared to the first day (Figure 1). In addition to fermentation and gas generation, which continued for seven days, there was also a change in the color of the samples. The amount of organic residues was decreasing. A pungent unpleasant odor was present.

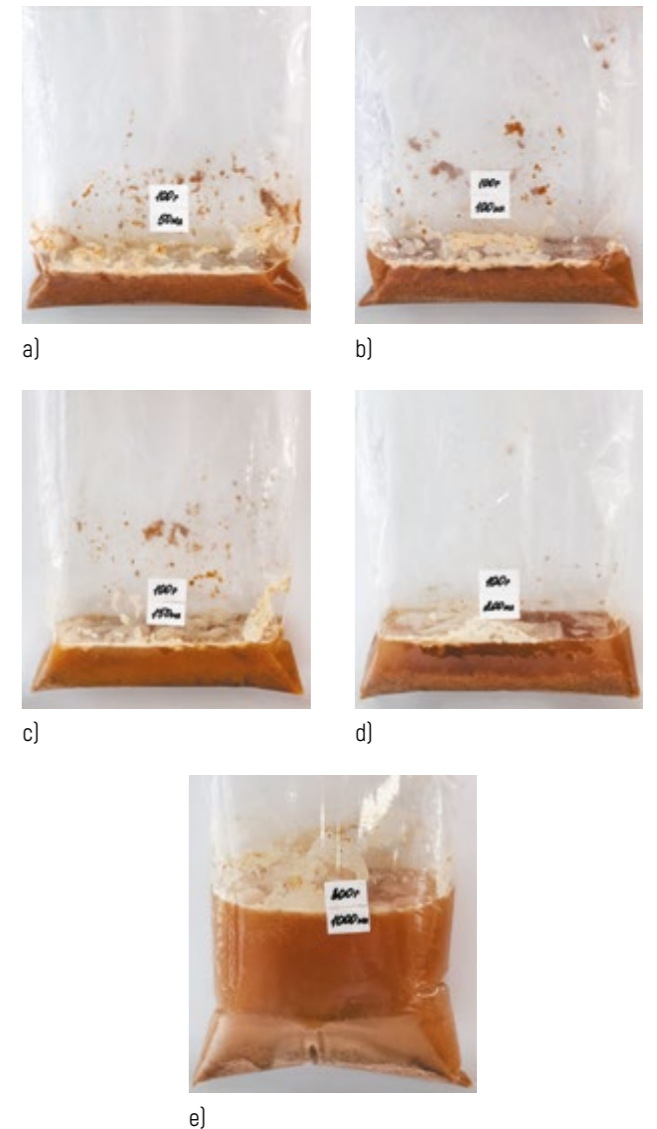

Figure 1 – Second day of food waste biorecycling: a – 50 ml of inoculum; b – 100 ml of inoculum; c – 150 ml of inoculum; d – 200 ml of inoculum; e – control

These observations indicate correctly selected conditions for the development and nutrition of microorganisms. The biodegradation of organic residues proceeded actively.

On the tenth day of the experiment (three days after adding the nitrogen-fixing culture of *Azotobacter vinelandii* BIM B-75), there was a slight gas formation as well as a change in the color of all samples from dark brown to beige (Figure 2). The odor became less pungent and unpleasant.

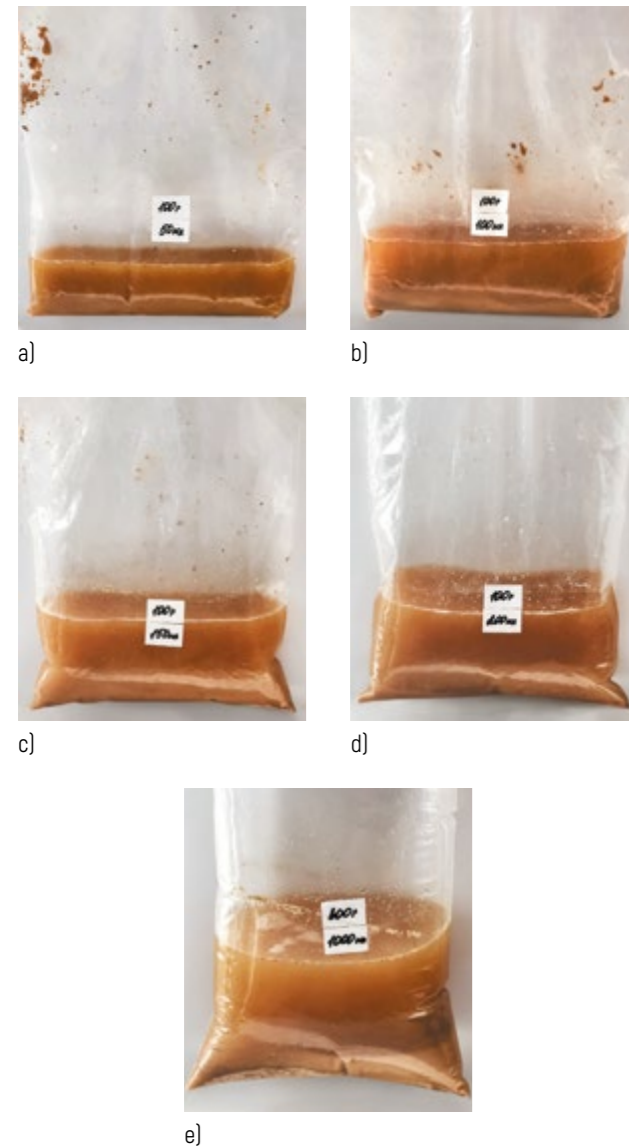

Figure 2 – Tenth day of food waste biorecycling: a – 50 ml of inoculum; b – 100 ml of inoculum; c – 150 ml of inoculum; d – 200 ml of inoculum; e – control

After finishing the experiment, the resulting liquid compost was examined for TMC and for nitrogen content to compare its amount before the addition of nitrogen-fixing bacteria and after. The results are presented in Table 3.

Table 3 – Results of biodegradation of organic residues with the help of cellulolytic and nitrogen-fixing microorganisms

Inoculum volume	Nitrogen content in sludge, mg/100 g		TMC, CFU/ml	
	7 th day	10 th day	7 th day	10 th day
50 ml	2,494.2	2,255.06	9×10^9	1×10^9
100 ml	3,228.2	3,360.8	3×10^9	5×10^8
150 ml	1,172.4	4,251.85	9×10^8	1×10^8
200 ml	2,252.7	3,859.29	4×10^9	4×10^8
Control	2,575.6	5,227.27	3×10^8	3×10^7

The addition of *Azotobacter vinelandii* BIM B-75 has increased the nitrogen content in the samples by an average of 30 % within three days. Compost with 150 ml inoculum volume and control had the best result. The TMC index has decreased in all samples but not significantly. This may indicate a lack of oxygen for microorganisms due to gas generation.

Microorganisms Predominant at Biorecycling of Organic Waste

In addition to chemical analysis, microorganisms were identified. This process is one of the most important and time-consuming stages of biological research. It was carried out to compare the microorganisms contained in the initial inoculum and the obtained compost to identify new bacteria that appeared during the fermentation process.

Identification of species and generic assignment of microorganisms after biorecycling was carried out by several methods. The result was generated from the pooled data. Morphology was studied by smear microscopy and staining by Gram method. Culture properties were determined by sowing the culture on solid agarized media, taking into account the shape, edge contour, size, value (diameter), color of colonies, their structure and consistency. At the same time, the biochemical activity of cultures, including oxidase and catalase activity, was investigated using differential diagnostic media.

Before setting up the experiment, Gram staining of microorganisms (*Azotobacter vinelandii* BIM B-75, *Aeromonas* sp., *Citrobacter* spp., *Bacillus amyloliquefaciens* BIM B-1236, *Paenicostridium* sp.) that were planned to be used for inoculum was conducted (Figure 3).

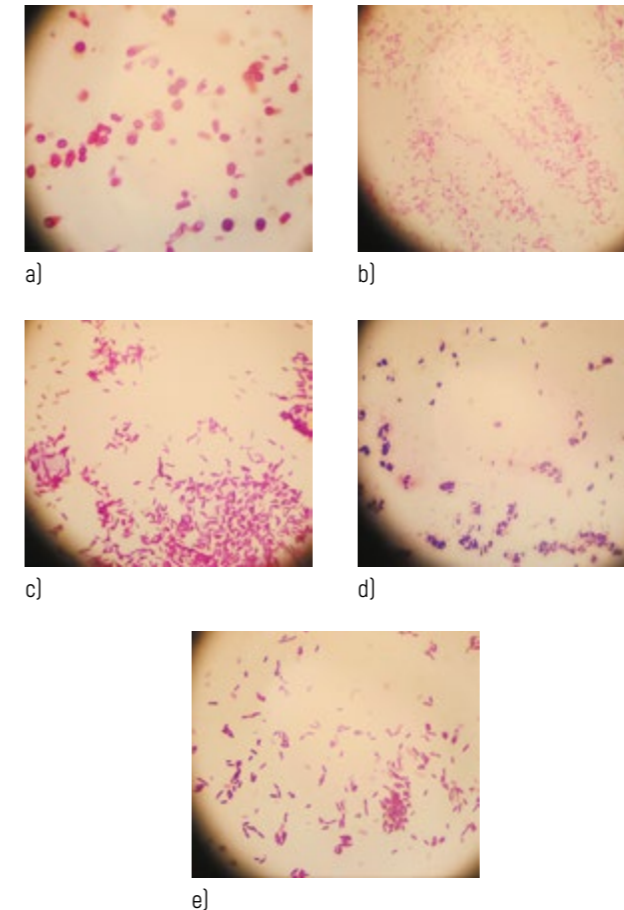

Figure 3 – Stained cultures of microorganisms under the microscope: a – *Azotobacter vinelandii* BIM B-75; b – *Aeromonas* sp.; c – *Citrobacter* spp.; d – *Bacillus amyloliquefaciens* BIM B-1236; e – *Paenicostridium* sp.

After the first and second stages of biorecycling, the identification revealed not only microorganisms that were in the initial inoculum (*Azotobacter vinelandii* BIM B-75, *Aeromonas* sp., *Citrobacter* spp., *Bacillus amyloliquefaciens* BIM B-1236, *Paenicostridium* sp.) but also gram-negative and gram-positive cocci (Figure 4). The appearance of these bacteria can be explained by the fact that food waste is subject to the natural process of putrefaction.

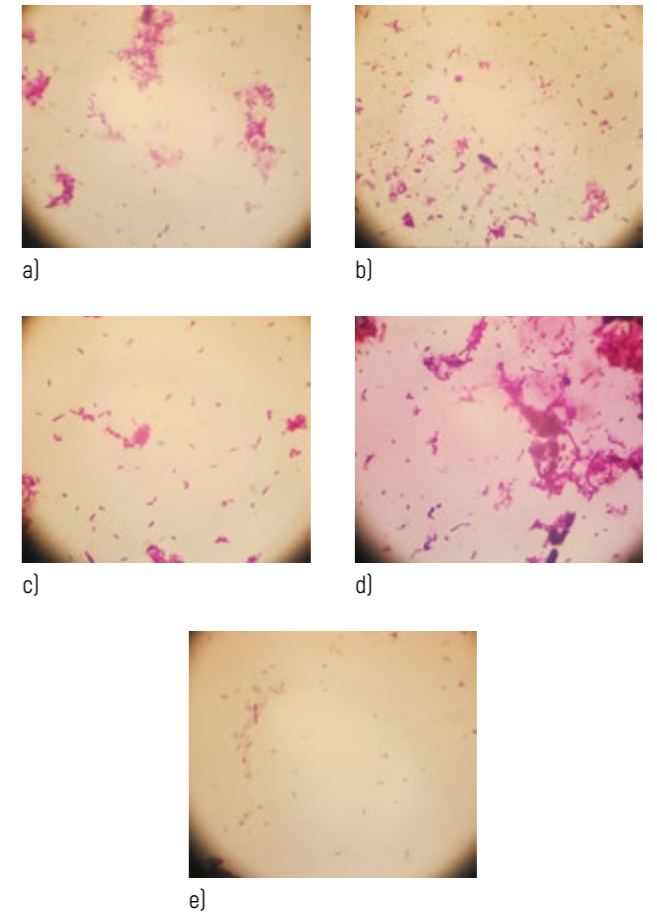

Figure 4 – Stained cultures of microorganisms under the microscope after the second stage of biorecycling: a – 50 ml of inoculum; b – 100 ml of inoculum; c – 150 ml of inoculum; d – 200 ml of inoculum; e – control

Use of Biorecycled Organic Matter as Fertilizer for Plants

An experiment was set up in laboratory conditions to determine the suitability of fermented residue as organic fertilizer with selected bacterial associations [11].

In accordance with the concept by engineer A. Unitsky [12], the ECH will have the necessary set of tools to ensure crop growth, including a fertile soil layer and associations of agronomically valuable soil microorganisms. The conditions created in the experiment were as similar as possible to those specific to the ECH. Light soil with a volume of 20 l was used, sandy loam with the content of the following microelements (mg/kg of soil): N – 45, P – 68, K – 80, Mg – 12, Ca – 14, Fe – 0.04, Mn – 0.01. It was supplemented with organic residues

after biorecycling in different variation (Table 4). The temperature during growth and development of cultures was 25–28 °C.

The research object – lettuce (*Lactuca sativa* L.) – has a high growth rate and quick responsiveness to various elements and components in the soil. Organic residues were applied to it before sowing the crops according to Table 4; then a physiological analysis of plants was carried out.

Table 4 – Soil mixture variants at pH 6.8

Soil composition	Content of mineral components, mg/kg of soil					Addition of organic part, g/kg of soil
	N	P	K	Mg	Ca	
Control without the addition of components	45	68	80	12	14	-
Control with NPK addition	50	80	140	12	20	-
Variant 1	45	68	80	12	14	0.005
Variant 2						0.002
Variant 3						0.05
Variant 4						0.02
Variant 5						0.15
Variant 6						0.1
Variant 7						0.2
Variant 8						0.25

Bacteria contained in the soil did not have a pathogenic load on seed germination but also had no direct effect on growth and development. No rots or defects were observed on the root system of sprouts during visual inspection. Leaf plates at germination looked viable and healthy.

In the course of the experiment, sowing was carried out on selective media for detection of pathogenic microorganisms on lettuce leaves: *Escherichia coli*, *Salmonella*, *Enterobacter* family, *Staphylococcus aureus*. The results showed the absence of fungal and bacterial diseases.

The data obtained in the experiment are presented in Table 5. Soil variants 4 and 5 had the best result compared

to the control with NPK addition. Soil variants 3, 6 and 7 performed well: average plant size was 27.5 cm.

Table 5 – Growth performance of lettuce

Soil composition	Average size of lettuce with root, cm	Average size of leaf plate, cm ²
Variant 1	24	13.7
Variant 2	25	12.8
Variant 3	27.5	15.4
Variant 4	31	12.1
Variant 5	30	13.3
Variant 6	27.1	13.4
Variant 7	28	12
Variant 8	23.3	11.9
Control without the addition of components	25	10.8
Control with NPK addition	26	11.7

Further, variant 3 showed rapid growth of lettuce compared to the control with NPK – five times higher. The plants in variant 1 also showed the same behavior, but they surpassed the control one by about four times (Figure 5).

The number of leaf plates in all variants of the experiment did not change, which indicates the stage-by-stage development of plants provided by the genetic program. At the same time, the leaf area differed depending on the volume of inoculum applied. Thus, in variant 3 it amounted to 15.4 cm² (32 % more than in the control with NPK), in variant 1 – 13.7 cm², in variant 6 – 13.4 cm². The increase in leaf plate can be associated with two main factors: assimilation of nitrates and nitrites in free form, which are in the soil, and the presence of extracellular enzymes of bacteria, similar in action to phytohormones or elicitors affecting growth-stimulating parameters.

When the level of hormones increases, growth-stimulating processes are triggered in plants, resulting in an increase in internodes and crop height, but this was not recorded in the experiment.



Figure 5 – Demonstration of the effect of biorecycled organic matter on lettuce growth and development compared to the control: a – variant 1; b – variant 3; c – variant 5; d – variant 7; e – variant 2; f – variant 4; g – variant 6; h – variant 8; i – control without the addition of components; j – control with NPK addition

Taste qualities of *Lactuca sativa* L. were evaluated according to a five-point quality system, where 1 is a rancid, sour taste with weakly pronounced aroma of greens; 2 is a sour taste with a mild aroma of greens; 3 is a mildly

bitter taste, aroma of fresh greens; 4 is a weakly pronounced bitter taste with aroma of greens; 5 is a strongly pronounced taste without bitterness. The evaluation was carried out by a tasting group, which included 30 people of different

gender and age. The average tasting score for all variants is demonstrated in Figure 6.

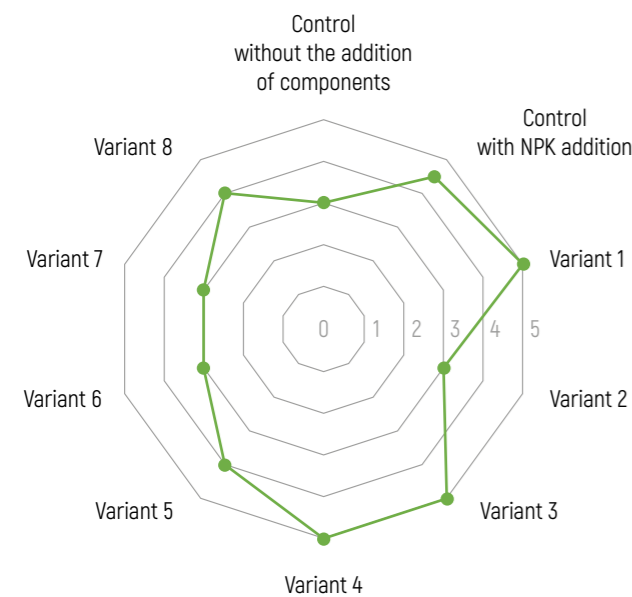

Figure 6 – Evaluation of taste properties of lettuce grown in different soils

Taste parameters of lettuce in variants 1, 3 and 4 were better than in the control with NPK addition. In all other variants, the plants did not reach the indicators of this control.

Conclusion

In an enclosed ecosystem of terrestrial type, it is required to apply means to maintain the autonomy of its existence. Microbiological utilization is recommended for use in the ECH to solve environmental problems related to waste generation.

In the course of the research, there were selected agronomically valuable microorganisms, with the help of which the process of biorecycling of food waste was carried out. On the fourth day of the experiment, organic residues were almost completely decomposed. The products of their fermentation were applied as an organic fertilizer when sowing lettuce. The results of the experiment showed that in soil variants 1, 3 and 6 the leaf plate area was on average 2.5 cm² larger than in the control with NPK; in variants 4, 5 and 7, the size of lettuce with root is on average 3.7 cm more than in the control with NPK.

Thus, the recycling of organic waste, carried out with the help of microorganisms, will make it possible not only to reduce the load on the enclosed ECH system but also to produce, using fermentation products, an efficient, environmentally friendly and economical bioorganic fertilizer, the main purpose of which is to increase yields, accelerate the growth and germination of crops. In addition, biorecycling can become a method to clean the water, land and air of the ECH enclosed ecosystem from organic pollution as well as to use recycled waste in organic agriculture, completely excluding the application of chemical fertilizers.

References

1. Sopilko, N.Yu. *Pererabotka otkhodov: analiz mirovykh tendentsiy [Waste Recycling: Analysis of Global Trends]* / N.Yu. Sopilko // *Tvordyye bytovyye otkhody*. – 2011. – No. 11 [65]. – P. 42–44.
2. *Population [Electronic resource]*. – Mode of access: <https://www.un.org/en/global-issues/population>. – Date of access: 20.07.2023.
3. *Ob ob'yomakh sbora vtorichnykh material'nykh resursov i otkhodov tovarov i upakovki, razmerakh raskhodovaniya denezhnykh sredstv, poluchennykh ot proizvoditeley i postavshchikov v 2021 godu [On the Volumes of Collecting Secondary Material Resources and Waste of Goods and Packaging, the Amount of Spending Funds Received from Producers and Suppliers in 2021]* [Electronic resource]. – Mode of access: https://www.vtoroperator.by/upload/iblock/e23/kfq436cpp0u2r1xltplveqd519trk6a/operator_2021_0.pdf. – Date of access: 20.07.2023.
4. *Kostecka, J. Food Waste in the Organic Recycling System and Sustainable Development* / J. Kostecka, M. Garczyńska, G. Paćzka // *Problemy Ekorozwoju*. – 2018. – Vol. 13, No. 2. – P. 157–164.
5. *Novyye svalki sozdadut v Minske i drugikh gorodakh [New Waste Landfills Will Be Created in Minsk and Other Cities]* [Electronic resource]. – Mode of access: <https://sputnik.by/20220603/novye-svalki-sozdadut-v-minske-i-drugikh-gorodakh-1063234084.html>. – Date of access: 20.07.2023.
6. *Biotekhnologiya i mikrobiologiya anaerobnoy pererabotki organicheskikh kommunal'nykh otkhodov [Biotechnology and Microbiology of Anaerobic Treatment of Organic Municipal Waste]: Multiauthored Monograph* /

ed. A.N. Nozhevnikova [et al.]. – Moscow: Universitetskaya kniga, 2016. – 320 p.

7. *Sister, V.G. Vybór tekhnologiy obezvrezhivaniya otkhodov s uchotom ikh sostava i svoystv [Selection of Waste Neutralization Technologies Taking into Account Their Composition and Properties]* / V.G. Sister, A.N. Mirnyy // *Tvordyye bytovyye otkhody*. – 2009. – No. 1 [31]. – P. 16–21.
8. *Microbial Strategies for Bio-Transforming Food Waste into Resources* / P. Sharma [et al.] // *Bioresource Technology*. – 2020. – Vol. 299. – 122580.
9. *Unitsky, A. String Transport Systems: On Earth and in Space* / A. Unitsky. – Silakrogs: PNB Print, 2019. – 560 p.
10. *Unitsky, A. Soil and Soil Microorganisms in EcoCosmo-House Biosphere* / A. Unitsky, E. Solovyova, N. Zyl // *Non-Rocket Space Industrialization: Problems, Ideas, Projects: Collection of Articles of the II International Scientific and Technical Conference, Maryina Gorka, Jun. 21, 2019* / *Astroengineering Technologies LLC; ed. A. Unitsky*. – Minsk: Paradox, 2019. – P. 179–183.
11. *Zayats, V.S. Protektornaya sposobnost' ekzogennykh elisitorov iz Ganoderma lucidum pri indukcii solevogo stressa u kress-salata [Protective Ability of Exogenous Elicitors from Ganoderma Lucidum at the Induction of Salt Stress in Cress]* / V.S. Zayats, I.V. Naletov, E.A. Kryukov // *Nastoyashcheye i budushcheye biotekhnologii rasteniy: Proceedings of the International Scientific Conference, Minsk, May 24–26, 2023*. – Minsk: IVTS Minfina, 2023. – P. 75.
12. *Unitsky, A.E. Lokalizatsiya ob'ektov promyshlennogo naznacheniya na krugovoy ekvatorial'noy okolozemnoy orbite [Localization of Industrial Objects in Circular Equatorial Near-Earth Orbit]* / A.E. Unitsky, A.V. Kushnirenko, Ye.N. Kulik // *Bezraketnaya industrializatsiya blizhnego kosmosa: problemy, idei, projekty: Collection of Articles of the III International Scientific and Technical Conference, Maryina Gorka, Sep. 12, 2020* / *Astroengineering Technologies LLC; Unitsky String Technologies Inc.; ed. A.E. Unitsky*. – Minsk: StroyMediaProyekt, 2021. – P. 230–245.





UDC 665.58

Development of Cosmetic Formulations Containing Vitamin D for Use in the EcoCosmoHouse

Y. Viaremka

A. Kaliada

Unitsky String Technologies Inc.,
Minsk, Belarus



The article reviews the issues regarding possible deficiency of vitamin D for the inhabitants of the EcoCosmoHouse (ECH) and analyses the sources and ways to replenish its deficiency, as well as contains solutions to this problem. The variants of vitamin D application in cosmetics are described. There are cosmetics formulations with natural components containing vitamin D as an accompanying substance and formulations where vitamin D is included as a separately dosed ingredient. The purpose of the research is to develop cosmetics with vitamin D, which can be applied to compensate for its possible deficiency during the prolonged stay of people in Earth's orbit. The tasks are as follows: to analyze the sources of vitamin D and the ways of its delivery to the body as well as to review ways to replenish lack of vitamin D with the help of these sources in the ECH conditions; to choose the type of cosmetics that will be used as a source of vitamin D; to select the components and to prepare experimental samples of the cosmetics containing vitamin D.

Keywords:

active ingredients, cosmetics with vitamin D, EcoCosmoHouse (ECH), inactive form of vitamin D, UV radiation, vitamin D.

Introduction

Nowadays, all cosmetic manufacturers are working on researching and obtaining new and efficient ingredients that will help in solving important problems in the field of cosmetology and medicine.

One of the most important issues today is vitamin D deficiency in the human body. Its lack can be compensated and dermatological problems can be prevented not only by UV radiation, properly selected nutrition or taking medications but also by using special cosmetics containing vitamin D, which are presently not widespread enough. In the conditions of an enclosed ecosystem, this issue is the most relevant and should be further considered in detail.

Vitamin D, Its Functions and Sources

Vitamin D is known to be essential for the regulation of numerous physiological processes. Its main effect is on bone health, as it helps calcium to overcome the barrier between the gastrointestinal tract and blood and also participates in its absorption by the small intestine. The result of calcium and vitamin D deficiency is the osteoporosis. Its consequence is a decrease in bone density, which leads to an increased risk of fractures [1].

A considerable amount of data indicates that vitamin D is responsible not only for maintaining calcium homeostasis but also skin homeostasis. It actively supports dermal innate and adaptive immunity [2, 3], plays an important role in the development of cognitive functions, regulation of the reproductive system and also stimulates the immune system, thereby improving the overall health of the body [1].

Vitamin D deficiency is associated with a large number of diseases, including osteoporosis, rachitis, certain forms of cancer and pathologies of the cardiovascular system. In addition, there are discussions about the influence of this biologically active substance content in the human body on the neurological and mental state [3].

It is generally accepted that vitamin D levels with values ≥ 30 ng/ml (75 nmol/l) are sufficient to maintain human health. Vitamin D deficiency is characterized by a range of 21–29 ng/ml (52–57 nmol/l), and values below 20 ng/ml (50 nmol/l) indicate its lack [1].

Currently, six forms of vitamin D are distinguished, which can be obtained both naturally and artificially. However, only two of them are of greatest interest to the human body – ergocalciferol (D_2) and cholecalciferol (D_3) [1].

There exist several sources of vitamin D intake, one of the main ones being food intake. There are relatively few food items enriched with this vitamin: fatty fish meat (salmon, trout), caviar, eggs and dairy products. With such a diet, vitamin D_3 enters the body directly. Some mushrooms contain vitamin D_2 , but its index in them varies depending on the species. For example, the maximum level is found in maitake, shiitake and oyster mushrooms [4, 5].

Although vitamin D is present in commonly consumed foods, its concentration in them is quite low. The most vitamin D-rich foods (meat, fatty fish and eggs) can cover about 10 % of the body's need for this biologically active substance. Even with a great desire, a person is not able to consume such amount of these products to fill the deficiency of vitamin D. The conditions under which they are grown and obtained should also be taken into account. For example, fish caught in the sea contains four times more vitamin D than fish grown in an artificial environment [6].

Thus, being in Earth orbit for a long time and following a healthy diet, the EcoCosmoHouse (ECH) residents do not have the opportunity to remove the need for vitamin D through food intake.

Another way of vitamin D intake is additional consumption of dietary supplements (DSs). The recommended amount is 400 IU/day [1]. However, DSs containing vitamin D may interact with some types of drugs, which in turn limits the number of people who can make up for vitamin D deficiency with supplements. One should not forget that DSs and medicines cause various types of liver damage, which manifest themselves over time. And despite the fact that DSs are not classified as drugs, there is a risk of overdose, which means that their long-term consumption requires constant monitoring of biochemical parameters [1].

In addition, a significant disadvantage of the use of DSs is their insufficient study and unconfirmed effectiveness. The situation is complicated by the fact that people purchase such products on their own, without consulting a specialist, without knowing their properties and side effects [7].

The main source that promotes the synthesis of vitamin D (Figure 1) is UV radiation. Vitamin D conversion begins with the conversion of 7-dehydrocholesterol, which is found in the epidermis. The UV radiation from the sun or artificial light sources convert 7-dehydrocholesterol into cholecalciferol, i.e., vitamin D_3 . Then it passes from the epidermis into the bloodstream with the help of a binding protein. After that, it is transported to the liver, where hydroxyl groups are attached to it. As a result, the active form of vitamin D_3 is created – 1.25-dihydroxycholecalciferol, also called calcitriol [8].

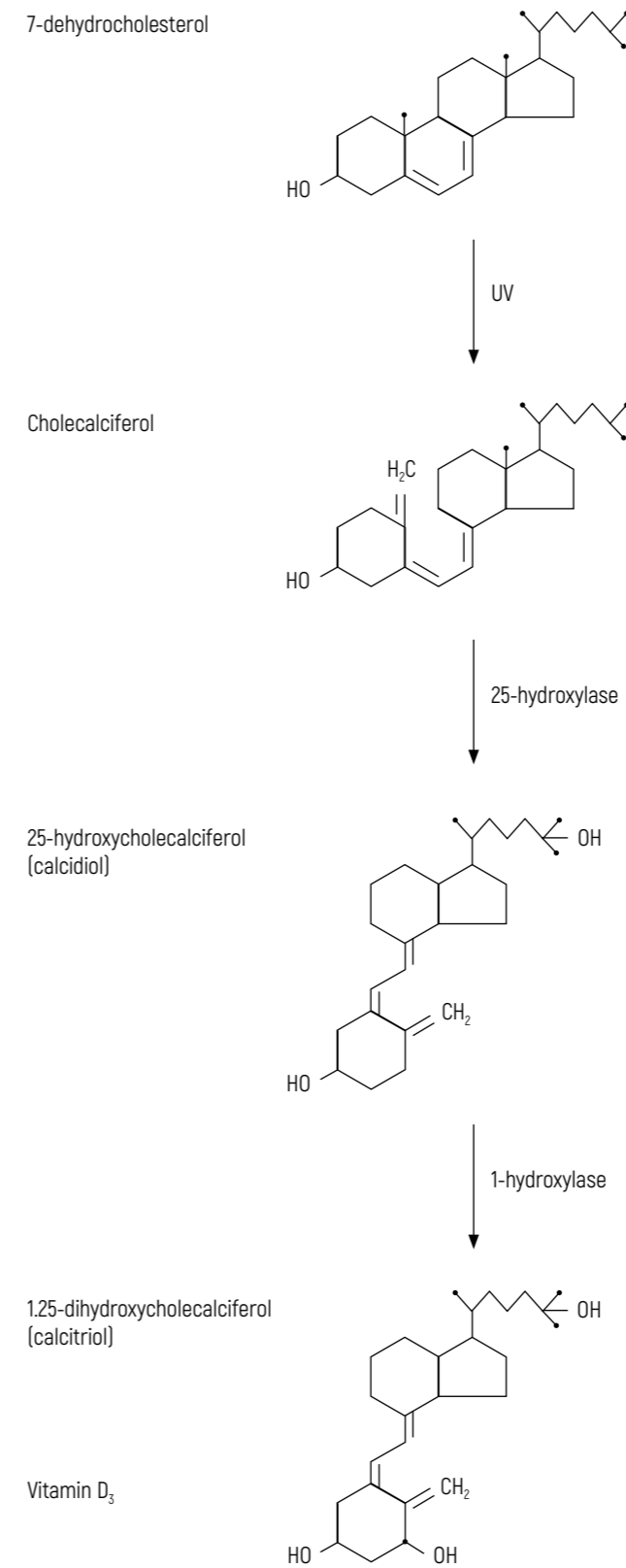

Figure 1 – Vitamin D synthesis

However, under the ECH conditions, humans will not receive the necessary amount of vitamin D synthesized under the action of natural solar radiation. This is due to the fact that the space of the space house, where people will stay, is isolated from sunlight. As an alternative source of light required for full human functioning, plant and animal development, it is possible to create artificial lighting with a spectrum close to natural light [9].

Light-emitting diodes (LEDs) can be one of the options for such artificial lighting and an alternative source of UV radiation that promotes vitamin D synthesis. As to previous tests [10], UV LEDs of UVB type with a wavelength of 293 nm are 24 times more efficient for vitamin D production compared to natural sunlight, which, accordingly, reduces the required time of exposure of human skin to UV radiation.

In addition to the wavelength of the radiation source and the time of its exposure, the amount of vitamin D synthesized directly depends on the area of the body surface, which is exposed to UV radiation. It is scientifically confirmed that to synthesize the recommended daily amount of vitamin D (400 IU for an adult) it is necessary to expose 1.5 % of the skin surface to UVB-type LEDs with a wavelength of 293 nm for 30 s. These values differ significantly from the same parameters for natural solar radiation: 3.9 % of the skin surface for 30 min [10].

Depending on individual specifics, in particular the skin phototype, the body's response to UV radiation is also different: people with dark skin produce the required amount of vitamin D more slowly than people with light skin [11]. However, light-skinned people are more susceptible to the carcinogenic and mutagenic effects of UV radiation, which is a major risk factor for skin cancer [12] and, therefore, one of the criteria that affects the degree of universality of vitamin D production by this method.

There have been considered the other negative aspects of this approach. UV radiation is often used for therapeutic purposes, as it has a favorable effect on human health, initiating the natural synthesis of vitamin D and activating many processes necessary for the normal vital activity of the body (metabolism, cardiovascular system functioning, enzymatic activity). However, overexposure to UV radiation from both the sun and light from artificial sources is associated with serious health risks [13]. The negative effects of UV radiation can manifest as skin burns, dermatitis, atrophy, pigment changes, appearance of wrinkles and skin malignancies. The most dangerous consequence of excessive exposure to UV radiation is the risk of developing melanoma, which is considered a deadly form of skin cancer.

Experiments have been conducted showing that UVB rays, which are considered to be the source of vitamin D synthesis, have the strongest oncogenic effect [14]. Therefore, it is problematic to clearly distinguish the level of favorable and unfavorable effects of UV radiation on humans. For this purpose, it is important to strictly follow the recommendations on the time and frequency of exposure to irradiation, taking into account the individual specifics of the organism [15].

According to research results, after a long flight, astronauts experience a decrease in bone density. Such changes are explained by the fact that during a long stay in space, the crew does not receive the necessary amount of sunlight, which influences vitamin D formation. In addition, the lack is not replenished by food products. The conditions of human stay in the ECH are close to the conditions on the International Space Station, therefore, the problem of vitamin D deficiency remains relevant [16].

Based on the currently available data, it is clear that in order to achieve a sufficient level of vitamin D in the human body without harm to health, it is necessary to look for alternative sources of this biologically active substance. We propose to use in the ECH special cosmetic products that contain vitamin D and help to compensate for its lack in the organism.

Benefits of Using Cosmetics Containing Vitamin D

The use of vitamin D in the production of cosmetics has a number of advantages in contrast to the previously discussed ways of its intake into the body. In addition to partially replenishing the need for this useful substance, a local application of vitamin D in cosmetics has a positive effect on the skin, which makes cosmetic products indispensable for daily care, treatment of skin diseases and prevention of premature skin aging. This component has a high degree of protection from the damaging effects of UV radiation, has an anti-inflammatory and antibacterial effect, contributes to strengthening the immune system of the skin, preventing moisture loss and dryness of the skin, fights the first signs of such diseases as acne, rosacea, atopic dermatitis [1].

With the years passing, the level of vitamin D synthesis in the body decreases, therefore, the skin becomes flabby and dry, age-related changes appear. Vitamin D helps to remove signs of aging, improves skin elasticity, enhances its radiance, suppresses inflammatory processes in tissues and resists the appearance of wrinkles [17].

Methods of Incorporating Vitamin D into Cosmetic Formulations

There are the following ways of including vitamin D in cosmetic products:

- as a separately dosed component;
- as a related substance in the composition of natural raw materials.

As a potential separately dosed component, it has been considered the two most common forms of vitamin D that have low toxicity and can be contained in cosmetic products in an increased quantity [17].

According to researches, when total equivalent doses of vitamin D₂ (considering regular use) and D₃ (considering periodical use) are applied, vitamin D₃ accumulates most efficiently in the dermis layers [18].

However, when introducing vitamin D₃ into cosmetics, difficulties arise due to the instability of this form of the vitamin and, consequently, the difficulty of dosing. Therefore, in the cosmetics developed, vitamin D₃ is used in the form of an inactive form – 7-dehydrocholesterol, which transforms into vitamin D₃ during photoisomerization [19].

The safety of using 7-dehydrocholesterol in preparations of local action lies in the fact that it can accumulate in the skin, forming its own biological reserve, but the active form of vitamin D is obtained only when it is necessary to replenish its deficiency in the body [20].

For transportation to the epidermis, 7-dehydrocholesterol, being a fat-soluble component, must be in complex with β-cyclodextrin, a carbohydrate that provides encapsulation of fat-soluble components in aqueous solutions [21].

Based on earlier studies on the use of the active form of vitamin D in preparations of local action [22], it was decided to introduce 7-dehydrocholesterol in cosmetics in an equivalent volume – 5,000 IU in 1 g of a product.

The amount of β-cyclodextrin required to encapsulate 7-dehydrocholesterol was calculated based on a ratio of 100 : 1 [23].

The second method of including vitamin D in the composition of cosmetics is the employment of natural raw materials, where this vitamin acts as a related substance.

The natural raw materials used in the production of cosmetics are most often plant-based and enriched with vitamin D₂. Examples of such sources are, first of all, extracts of algae, mushrooms, lichens. In rare cases, vitamin D₃ is found in vegetative raw materials. It is contained mainly in the fruit parts of representatives of the cereal, nightshade and laurel families [6, 24].

However, it is problematic to dose the amount of vitamin D intake through the use of plant-based cosmetic components, therefore, this method is more suitable as a supplementary one to maintain the optimal vitamin D level already achieved in the body.

Development of Compositions of Cosmetic Products with Vitamin D

The following cosmetics for the body have been developed in Unitsky String Technologies Inc. (Minsk, Belarus): fluid, cream, spray, deodorant. The choice of this type of preparations is conditioned by the fact that they are indelible skin-care products and have a long contact time with the skin necessary for transportation of active substances, including vitamin D, to the deep layers of the skin.

Due to the minimalistic but multifunctional set of components and the absence of fragrances, the proposed cosmetic products are versatile and can be used by both women and men.

The developed cosmetics products containing 7-dehydrocholesterol are characterized by the following advantages.

1. Body fluid. Designed to moisturize the skin of the face and body, maintain its elasticity and firmness.

The active components included in the composition of this cosmetic product:

- hydrolyzed soy protein. It has a rejuvenating and regenerating effect, filling the skin with moisture and increasing its elasticity;
- 7-dehydrocholesterol. It is a precursor of vitamin D, stimulates the production of skin defenses properties, relieves skin irritation and redness;
- lemon balm extract. It prevents dryness and peeling, activates metabolic processes in skin cells, has a soothing effect.

A regular use of this body fluid helps to replenish vitamin D deficiency in the body, minimizes the negative effects of UV radiation and stimulates the formation of a protective stratum corneum of the skin.

2. Body cream. It is designed to soften, soothe and prevent dehydration of face and body skin.

The active ingredients included in the composition of this cosmetic product:

- 7-dehydrocholesterol. It reduces the skin's sensitivity to external factors, enhances its radiance and helps to fight skin diseases;

- betaine. It has a complex effect on the skin, normalizing the hydrolipidic balance, retaining moisture and attributing softness and silkiness;

- rhodiola rosea extract. It tones up the skin and relieves its puffiness, has a rejuvenating and anti-inflammatory effect.

Body cream is specially developed to saturate the skin with vitamin D, restore its lipid barrier and protect it from the negative impact of the environment.

Cosmetic products in which vitamin D present as a related substance are described below.

1. Body spray. It reduces irritation, tones up and normalizes the water balance of the skin of face and body.

The active components included in the composition of this cosmetic product:

- reishi mushroom extract. It improves skin immunity, evens out skin color, makes it smooth and velvety. Due to the presence of vitamin D, it actively fights the first signs of aging;

- tea mushroom extract. It has an antioxidant, anti-inflammatory and antimicrobial activity. B vitamins in the composition remove redness, peeling and dryness of the skin;

- rosehip extract. It moisturizes and tones up the skin, protects it from environmental pollutants and ultraviolet radiation. The available significant amount of vitamin C is involved in the synthesis of collagen.

Due to the vitamin D contained in reishi mushroom extract, the body spray contributes to the timely regeneration of the skin, preventing its dryness and flaccidity.

2. Deodorant for the body. It is intended for effective protection against odor and sweat during the day.

The active components included in the composition of this cosmetic product:

- avocado extract. It contains a large amount of vitamin D, nourishes and facilitates skin regeneration, slows down the aging processes, helps to restore skin elasticity and smoothness;

- calendula extract. It activates the protective functions of the skin, stimulates cell renewal, normalizes the functioning of the sebaceous glands;

- hyssop extract. It has an anti-inflammatory and antibacterial properties, has a cooling and soothing effect on the skin.

Due to the vitamin D present in the avocado extract, the effective regulation of sweat glands is accompanied by a gentle protection of skin from dryness and irritations.

Thus, the line of cosmetic products (Figure 2) enriched with vitamin D, developed in Unitsky String Technologies Inc., will be able to provide the ECH residents with a holistic care for all parts of the body, contributing to health promotion and replenishing the deficiency of necessary nutrients in the conditions of living in space. The proposed cosmetics are recommended for daily use, are not addictive, do not require an increase in the application dose and remain effective throughout the entire period of application. The content of predominantly natural ingredients is a distinctive feature of the developed care products, which is important for the increasing demand for safe and environmentally friendly cosmetics. Special technologies are used for its production, which allow the organic ingredients included in the composition of the cosmetics to retain their beneficial properties. It is reasonable to grow the main part of vegetative raw materials necessary to obtain the presented cosmetics in the ECH. This approach will minimize the cost of material transportation and significantly reduce the cost of production as well as guarantee that no fertilizers of genetic and chemical origin are used in the cultivation of plants and mushrooms, from which extracts are subsequently obtained, and only natural cultivation methods are applied [25, 26]. The residues of plant biomass formed after extracts obtaining can be subjected to destruction by micro- and macroorganisms, making the production waste-free, which is especially relevant in an enclosed system [9].



Figure 2 – The line of body cosmetics containing vitamin D: deodorant, spray, fluid and cream

Conclusion

Based on the analysis of possible vitamin D deficiency in the conditions of living in the ECH, it was concluded that it is necessary to search for alternative sources of vitamin D intake into the body, including obtaining and using vitamin D-containing cosmetics.

The lack of vitamin D in the organism of a person staying for a long time in Earth's orbit can be compensated by special cosmetic products created in Unitsky String Technologies Inc. These products, having a minimal list of natural components, combine the most functional substances, which are useful not only for skin condition, but also for health in general.

The developed versatile skincare cosmetics containing vitamin D help to fill its deficiency in the human body. The use of natural raw materials in the production of cosmetic preparations ensures their high quality and also harmonizes with the general concept of the fight for ecology, which implies a growing demand for natural and environmentally friendly cosmetics.

References

1. Pleshcheva, A.V. *Vitamin D i metabolizm: fakty, mify i predubezhdeniya* [Vitamin D and Metabolism: Facts, Myths and Misconceptions] / A.V. Pleshcheva, Ye.A. Pigarova, L.K. Dzeranova // *Ozhireniye i metabolizm*. – 2012. – No. 2 (31). – P. 33–42.
2. Kornisheva, V.G. *Znachenie vitamina D v immunnoy sisteme i patogeneze autoimmunnykh protsessov kozhi (obzor)* [Significance of Vitamin D in the Immune System and Pathogenesis of Autoimmune Processes of the Skin (Review)] / V.G. Kornisheva, K.S. Kukushkina // *Problemy meditsinskoy mikologii*. – 2018. – Vol. 20, No. 3. – P. 15–20.
3. Pigarova, Ye.A. *Neklassicheskiye efekty vitamina D* [Non-Classical Effects of Vitamin D] / Ye.A. Pigarova, A.A. Petrushkina // *Osteoporoz i osteopatii*. – 2017. – No. 20 (30). – P. 90–101.
4. Yeliseyeva, T.V. *Vitamin D – opisaniye, polza i gde sodержitsya* [Vitamin D – Useful Properties, Composition and Contraindications] / T.V. Yeliseyeva, A.V. Mironenko // *Zhurnal zdorovogo pitaniya i diyetologii*. – 2018. – Vol. 5, No. 3. – P. 52–66.
5. *Fiziologicheskaya potrebnost' i effektivnyye dozy vitamina D dlya korrektsii yego defitsita. Sovremennoye sostoyaniye problemy* [Physiological Requirement and Effective Doses of Vitamin D for Deficiency Correction. Current State of the Problem] / V.M. Kodentsova [et al.] // *Voprosy pitaniya*. – 2017. – Vol. 86, No. 2. – P. 47–62.
6. Goring, H. *Vitamin D – gormon solntsa. A yesli solnechnogo sveta nedostatochno?* [Vitamin D – the Sun Hormone. Life in Environmental Mismatch] / H. Goring, S.V. Kozhuchova // *Biokhimiya*. – 2015. – Vol. 80, iss. 1. – P. 14–28.
7. Iraklionova, N.S. *Vliyaniye biologicheskikh aktivnykh dobavok na organizm cheloveka* [Effect of Dietary Supplements on the Human Body] / N.S. Iraklionova, Ye.B. Sysuyev // *Uspekhi sovremennogo estestvoznaniya*. – 2013. – No. 9. – P. 96–97.
8. Snopov, S.A. *Mekhanizmy deystviya vitamina D na immunnuyu sistemu* [Mechanisms of Vitamin D Action on the Immune System] / S.A. Snopov // *Meditsinskaya immunologiya*. – 2014. – Vol. 16, No. 6. – P. 499–530.
9. Unitsky, A. *Features of Design of a Residential Space Cluster "EcoCosmoHouse" – Mission, Goals, Purpose* / A. Unitsky // *Non-Rocket Space Industrialization: Problems, Ideas, Projects: Collection of Articles of the II International Scientific and Technical Conference, Maryina Gorka, Jun. 21, 2019 / Astroengineering Technologies LLC, ed. A. Unitsky*. – Minsk: Paradox, 2019. – P. 51–57.
10. *Ultraviolet B Light Emitting Diodes (LEDs) Are More Efficient and Effective in Producing Vitamin D₃ in Human Skin Compared to Natural Sunlight* / T. Kalajian [et al.] // *Scientific Reports*. – 2017. – Vol. 7, iss. 1. – P. 11489.
11. Pavandeep, G. *Assessment of the Feasibility of Using Sunlight Exposure to Obtain the Recommended Level of Vitamin D in Canada* / G. Pavandeep, K. Sunil // *CMAJ Open*. – 2015. – Vol. 3, iss. 3. – P. 258–263.
12. *UV Radiation and the Skin* / J. D'Orazio [et al.] // *International Journal of Molecular Sciences*. – 2013. – Vol. 14, iss. 6. – P. 12222–12248.
13. Gushchin, M.O. *O povrezhdayushchem deystvii ul'trafiol'tovyykh luchey na kozhu cheloveka* [About the Damaging Effect of Ultraviolet Rays on Human Skin] / M.O. Gushchin, Yu.N. Proskurnova // *Mezhdunarodnyy studencheskiy nauchnyy vestnik*. – 2018. – No. 4, pt. 2. – P. 221–223.
14. Sample, A. *Mechanisms and Prevention of UV-Induced Melanoma* / A. Sample, Y.-Y. He // *Photodermatology, Photoimmunology & Photomedicine*. – 2018. – Vol. 34, iss. 1. – P. 13–24.
15. *Concurrent Beneficial (Vitamin D Production) and Hazardous (Cutaneous DNA Damage) Impact of Repeated Low-Level Summer Sunlight Exposures* / S.J. Felton [et al.] // *British Journal of Dermatology*. – 2016. – Vol. 175, iss. 6. – P. 1320–1328.
16. Khoshvaghti, A. *Vitamin D in Space* / A. Khoshvaghti // *Fads and Facts About Vitamin D* / ed. E.T. Zawada. – London: IntechOpen, 2019. – P. 63–80.
17. Khapalyuk, A.V. *Vitamin D i immunitet* [Vitamin D and Immunity] / A.V. Khapalyuk // *Lechebnoye delo*. – 2022. – No. 3 (82). – P. 14–20.
18. Hammami, M.M. *Differential Effects of Vitamin D₂ and D₃ Supplements on 25-Hydroxyvitamin D Level Are Dose, Sex, and Time Dependent: A Randomized Controlled Trial* / M.M. Hammami, A. Yusuf // *BMC Endocrine Disorders*. – 2017. – Vol. 17. – P. 12.
19. Raskina, K.V. *Istoriya "D"* [The "D"-story] / K.V. Raskina, Yu.Ye. Poteshkin // *Aktual'naya endokrinologiya*. – 2015. – No. 5. – P. 1–7.
20. *Kvartet zdorov'ya – novaya kontseptsiya sovremennoy profilakticheskoy i esteticheskoy meditsiny: vitamin D, vozmozhnosti vnutrennego i naruzhnogo primeneniya* [Health Quartet as a New Concept of Modern Preventive and Aesthetic Medicine: Vitamin D, Possibilities of Internal and External Application] / L.O. Vorslov [et al.] // *Kosmetika i Meditsina*. – 2015. – No. 4. – P. 36–45.
21. Loftsson, T. *Anomalous Properties of Cyclodextrins and Their Complexes in Aqueous Solutions* / T. Loftsson, H.H. Sigurdsson, P. Jansook // *Materials*. – 2023. – Vol. 16, iss. 6. – P. 1–15.
22. Bubshait, D.A. *Topical Vitamin D₃: A Randomized Controlled Trial (RCT)* / D.A. Bubshait, D.A. Al-Dakheel, F.M. Alanii // *Clinical Nutrition ESPEN*. – 2018. – Vol. 27. – P. 16–19.
23. *Solubility of Cyclodextrins and Drug/Cyclodextrin Complexes* / P. Saokham [et al.] // *Molecules*. – 2018. – Vol. 23, iss. 5. – P. 1161.
24. *Biofortified Tomatoes Provide a New Route to Vitamin D Sufficiency* / J. Li [et al.] // *Nature Plants*. – 2022. – Vol. 8. – P. 611–616.
25. Shakhno, K. *Medicinal Plants for EcoCosmoHouse. Selection, Growing Conditions, Scope of Application* / K. Shakhno, N. Zyl // *Non-Rocket Near Space Industrialization: Problems, Ideas, Projects: Collection of Articles of the IV International Scientific and Technical Conference, Maryina Gorka, Sep. 18, 2021 / Astroengineering Technologies LLC, Unitsky String Technologies Inc., ed. A. Unitsky*. – Minsk: StroyMediaProject, 2022. – P. 281–289.
26. Unitsky, A. *Medicinal and Edible Mushrooms in an Enclosed Ecosystem: Cultivation, Properties, Application* / A. Unitsky, A. Kostenevich // *Non-Rocket Near Space Industrialization: Problems, Ideas, Projects: Collection of Articles of the IV International Scientific and Technical Conference, Maryina Gorka, Sep. 18, 2021 / Astroengineering Technologies LLC, Unitsky String Technologies Inc., ed. A. Unitsky*. – Minsk: StroyMediaProject, 2022. – P. 267–278.



UDC 581.6:58.01/.07

Obtaining Natural Detergents from Licorice with Prebiotics in the EcoCosmoHouse Conditions

T. Tratsiakova

P. Buglak

N. Zyl

Unitsky String Technologies Inc.,
Minsk, Belarus



Options for using natural raw materials for obtaining the detergents in an enclosed ecosystem are considered. The results of an experiment on the production of laboratory samples of liquid soap from licorice (*Glycyrrhiza glabra* L.) with prebiotics are presented.

Keywords:

detergents, EcoCosmoHouse (ECH), enclosed ecosystem, licorice (*Glycyrrhiza glabra* L.), prebiotics.

Introduction

The residents of the EcoCosmoHouse (ECH) need detergents, which are better to produce in orbital conditions than to spend large financial resources on their delivery from Earth. In an enclosed ecosystem it is preferable to use plant raw materials to replace synthetic ones [1], which consist of complex mixtures of different substances. The main disadvantage of nonnatural detergents is their low decomposition rate, which causes them to pollute the environment. That is why the priority in this area is to replace such products with natural compositions and natural soap.

Surfactants of organic origin include:

- plant saponins (extracts of soap tree, soapwort and licorice);
- Castile soap (based on olive oil replacing animal fats);
- phosphatidylcholine (lecithin) derived from soy.

As a natural replacement for synthetic surfactants in shampoos and detergents, natural saponins (foam-forming substances) are used, being part of some plant extracts, such as soapwort, bark of the soap tree and licorice roots. The name "saponins" comes from the Latin *sapo* meaning soap. These are complex nitrogen-free organic compounds from glycosides of plant origin, which have surfactant properties. When shaken, the solutions form a thick persistent foam.

Description of Saponin-Containing Plants

Alpine Violet (*Cyclamen L.*)

It is a perennial herbaceous plant belonging to the primrose family (Figure 1) [2].



Figure 1 - Alpine violet

Saponins are found in the roots, which are in the form of tubers that grow large in soft and greasy soil. Technical saponins are obtained in the usual way – by extracting soap root with water and evaporating the resulting extract.

Dry tubers contain water-soluble substances (technical saponins) – 54.2 %, including pure saponins – 25.2 % [3].

White Campion (*Melandrium album (Mill.) Garcke*)

This one- or two-year herbaceous plant belongs to the clove family (Figure 2). Its roots contain technical saponins – 31.9 %, including pure saponins – 27.5 % [3].

White campion has quite few extraneous substances compared to other saponin-containing crops.



Figure 2 - White campion

Acanthophyllum glandulosum Bunge ex Boiss.

This is a perennial herbaceous plant or semishrub of the clove family (Figure 3). Its roots contain technical saponins – 40.5 %, including pure saponins – 32.02 % [3].



Figure 3 - *Acanthophyllum glandulosum*

Common Soapwort (*Saponaria officinalis L.*)

It belongs to perennial herbaceous plants of the clove family (Figure 4). In the studies [3, 4], technical saponins were isolated from the dried roots of common soapwort – 58.2 %, including pure saponins – 36 %.



Figure 4 - Common soapwort

Licorice (*Glycyrrhiza glabra L.*)

Licorice (sweet root, liquorice) is a perennial herbaceous plant of the legume family, known for its beneficial properties and has long been used all over the world (Figure 5). The medicinal raw material is the roots, which can be stored in gauze or paper bags in a cool dry room for 10 years.

According to [5], licorice contains a number of therapeutic biologically active compounds, such as triterpene saponins, flavonoids, coumarins and other phenols. The total amount of extractive substances obtained from the roots of the plant is 40 % of the weight of the raw material [6].



Figure 5 - Licorice

The main biologically active compounds are summarized in more detail in the Table below.

Table - Main biologically active compounds of licorice root

Substances	Content, %
Extractives	22.8–44.1
Triterpenoids	7.3–23.6
Carbohydrates (glucose, sucrose, starch)	18.2–34
Flavonoids	3–4
Steroids	1.5–2
Ascorbic acid	1.1–3.1
Essential oils	1.5–2
Asparagine	1–4
Resinous substances	1.7–4.1
Fats and fatlike agents	0.2–4.7
Proteins	6.2–10.1
Gums	1.5–6.5
Insoluble bitterness (in water)	1.8–4
Ash (overall)	4.9–9.7

The roots and underground shoots of licorice contain up to 23 % glycyrrhizin, which is the potassium and calcium salt of tribasic glycyrrhizic acid. It is a triterpene saponin that breaks down during hydrolysis into glycyrrhetic acid and two molecules of glucuronic acid, which gives the roots a tart-sweet flavor [7].

Licorice is a source of raw materials for food, perfumes, cosmetics, technical and other products. It has many groups of biologically active compounds: sugars, amino acids, pectins, microelements, etc. Glycyrrhizic acid, glycyrrhetic acid and their derivatives, flavonoids and polysaccharides are mainly used.

Licorice is a healthful medicinal plant, which is an additional plus and expands the scope of its use in the ECH conditions.

Licorice roots host nodule bacteria that enrich the soil with biological nitrogen, which will also be an undeniable advantage when cultivating licorice in light potting soils that are planned to be applied in an enclosed ecosystem. The aboveground vegetative part of licorice, which reaches 1.5 meter height, is rich in protein (up to 12 %) and is considered a nutritious fodder for farm animals [8]. Saponins, flavonoids, tannins, nitrogenous bases, organic acids, sugars and carotene are found in this part.

About 6 tons of aboveground biomass can be harvested from 1 ha of licorice in the second year after planting, and 15 tons in the third year. Its protein content is twice as high as in alfalfa, which makes licorice biomass a nutritious and valuable fodder (in dry form) for cattle and small ruminants [9]. Licorice root can be obtained in the third or fourth year [10], and the yield of dry root mass is about 6–8 t/ha.

There are a huge number of patents (more than 10,000) on the use of licorice [11]. It is included in preparations for the treatment of stomach, spleen, intestinal, viral diseases, including AIDS, as well as dermatitis, psoriasis, acne, eczema, cystitis, cholecystitis, pancreatitis, prostatitis; in formulations of choleric, laxative, diuretic, anti-allergic, antispasmodic action; in remedies for cough, bronchitis, conjunctivitis, arthritis, lumbago, hemorrhoids, osteoporosis, periodontal disease and even in agents that increase the activity of antitumor drugs indicated in oncology, etc. In [12] the maximum number of patent documents on this subject is given.

In cosmetology, licorice root extract is recommended for detergents, anti-wrinkle products, for skin rejuvenation, cleansing and brightening as well as for stimulating hair growth, hair treatment, etc. A positive point of using licorice in shampoos is its ability to clean the scalp and hair without drying them out. All this speaks of the undeniable advantages of choosing such a valuable and multipurpose plant culture as the object of the present study and the main ingredient of the developed detergent.

Description of Natural Cosmetic Supplements

In order for the natural cosmetic products manufactured to have a pleasant consistency and fresh aroma for a long time, optimal storage conditions must be ensured. To obtain the desired consistency, a natural thickener is needed, which in the experiment conducted by the authors were pectin and xanthan gum. Natural compounds that perform the function of antioxidants and preservatives in organic cosmetics are sea salt, citric acid and essential oils [13], also included in the formulation of cosmetic detergent. Consider the properties of these compounds in more detail.

Pectin

In cosmetic production it is in demand as a thickener and complexing agent [14]. It is a prebiotic – a carbohydrate contained in vegetables, fruits and cereals that creates a favorable nutrient environment for the reproduction of microflora.

Skin microflora is a variety of microorganisms living on its surface. It is part of the protective barrier of the body. Useful bacteria settle in a favorable nutrient environment and protect the skin from colonization by pathogens.

Pectin contains galacturonic acid, which has the property of retaining moisture, smoothing wrinkles and improving skin tone. In addition, the feasibility of using low-esterified pectin substances as an active detergent additive to shampoos and liquid soap, the pH of which ranges from 5.5 to 7.5, has been proved [15].

Citric Acid

The natural cosmetics obtained must retain its properties for a long period, so it is necessary to introduce preservatives of natural origin in its composition. One of them is citric acid, which is an acidity regulator, antioxidant and synergist of antioxidants; it is added for flavoring and as a natural preservative [16]. It can be involved as a dispersing and grinding component. It is susceptible to thermal and complete biodegradation. According to the European numerical codification of food additives, citric acid is classified as E330 and is included in the list of substances authorized for use in food and beverages.

Citric acid represents colorless crystals, similar in appearance to sugar. Its applications are:

- confectionery industry – as an acidulant and flavor enhancer;
- beverage industry – to give a sense of freshness. It is also a synergist, i.e., a substance that enhances the action of antioxidants, such as ascorbic acid;
- canning industry – as a preservative instead of vinegar, which is recognized as a carcinogen and the usage of which severely restricted in the food industry of most countries;
- cosmetology – as a pH regulator of many cosmetic preparations: elixirs, lotions, creams, shampoos, hair fixers, etc.

Sea Salt

It is characterized by a rich chemical composition, which is associated with its unique healing properties. This makes the substance very popular in cosmetology. Due to the high content of minerals and other elements, sea salt nourishes the skin, improves blood circulation, dries inflammation and strengthens capillaries, saturating them with healthful substances. For hair it is valuable because it accelerates their growth, makes the structure denser and curls more voluminous. Sea salt in cosmetics also works as an antiseptic, has anti-inflammatory and antimicrobial action.

Essential Oils

Tea tree essential oil [17] has effective antiseptic properties and at the same time is absolutely harmless to the human body. In addition, it has anti-inflammatory, astringent, antitoxic, antiviral, embalming, healing and fungicidal action. Due to these qualities, it is actively used in cosmetic products.

Rosemary essential oil has a wide range of health benefits, among them are analgesic, anti-inflammatory, antimicrobial. This substance is characterized by antioxidant activity [18].

Grapefruit essential oil has powerful antibacterial and antimicrobial properties, proves effectiveness against certain strains of fungi and has a citrusy aroma.

Frangipani (plumeria) essential oil gives a pleasant smell to the detergent and has a number of other valuable properties: it relieves inflammation, moisturizes and nourishes dry skin, helps to smooth fine lines and wrinkles.

Jasmine essential oil is not only known for its subtle fragrance but is also antiseptic, antibacterial and antifungal, does not irritate the skin and is therefore often used in skin and hair care products.

Experimental Part

In order to prepare a detergent, the roots of licorice were poured with water in the ratio of 1:5 by weight, kept in a boiling water bath for 30 min, drained the solution and again poured the roots with water in the ratio of 1:3 by weight, the treatment was repeated. The resulting decoction (550 ml) was centrifuged, divided into two parts, and different samples of detergent were made, while a thickener was used: in the first sample – xanthan gum; in the second – pectin, which is also a prebiotic (Figure 6).



Figure 6 – Detergents made from a decoction of licorice roots: 1 – with xanthan gum; 2 – with pectin

Since the detergents are all-natural, mold formed in the samples during their storage at a temperature of $(20 \pm 5) ^\circ\text{C}$: in the first one after 14 days and in the second one after a month. Proceeding from the fact that modern manufacturers guarantee storage of cosmetic products in the open form not more than one month, in the second case the necessary result was achieved. Accordingly, further work should include vacuum packaging and sterilization of containers, and various combinations of essential oils or plants should be examined.

To accurately confirm the presence of saponins in plant raw materials, reactions based on the physical and chemical properties of these substances were applied [19]. The qualitative reaction to saponins is foaming (Figure 7), which is not observed in other plants.

Saponins by chemical structure are divided into two groups: steroidal and triterpene. To determine the group, two test tubes was taken, one of which was filled with 5 ml of 0.1 mol/l NaOH and the other with 5 ml of 0.1 mol/l HCl. After that, 2–3 drops of decoction to each test tube were added and shook vigorously (Figure 8).

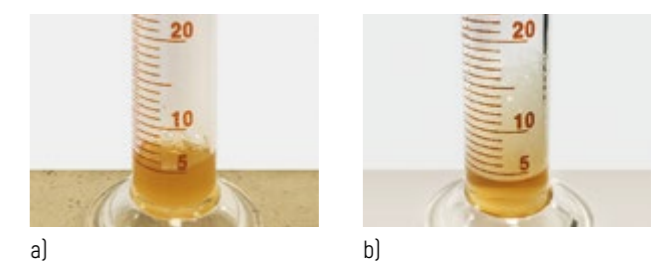

Figure 7 – Licorice root decoction: a – before shaking; b – after vigorous shaking for 30 s

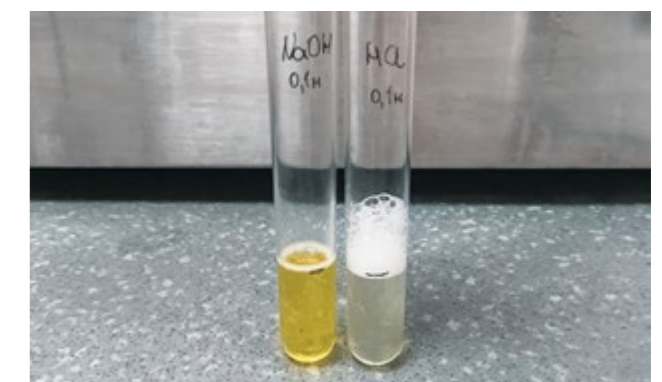

Figure 8 – Test tubes with NaOH, HCl and licorice root decoction

As a result, a persistent foam was formed in the test tube with acid. This indicates that the decoction contains acidic triterpene saponins, which include derivatives of glycyrrhizic acid, which has a favorable effect on the skin. Steroidal saponins give abundant foam in an alkaline environment.

Chemical evidence of the presence of saponins is their precipitation from aqueous solutions by barium and magnesium hydroxides, copper salts and lead acetate. Copper (II) sulfate was used in the experiment. The result is shown in Figure 9, which also confirms the presence of saponins [precipitate formed].

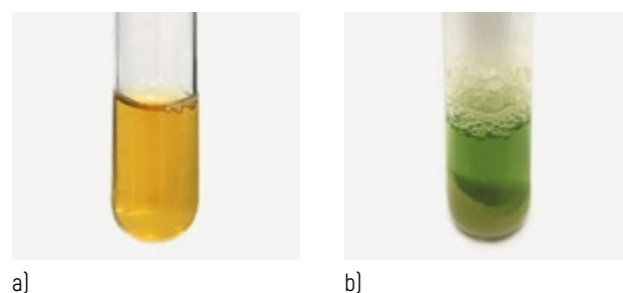

Figure 9 – Licorice root decoction:
a – pure; b – with addition of copper (II) sulfate

Conclusion

In this study, a liquid soap was obtained from licorice roots, which can be used as a shower gel or shampoo [3 in 1], since it has a favorable effect on the skin due to the content of glycyrrhizic acid. It was determined that the solution with xanthan gum can be stored at $(20 \pm 5)^\circ\text{C}$ for 14 days and with pectin for twice as long.

Since the product is all-natural and, therefore, perishable, it is necessary to provide for its vacuum packaging in the future. The obtained samples of liquid soap will be analyzed for compliance with Technical Regulations of the Customs Union “On the Safety of Perfumes and Cosmetics” and the shelf life of these preparations in hermetically sealed packaging will be established. In addition, the method of increasing the shelf life by adding various essential oils and their mixtures as well as decoction of the plants themselves to the detergents will be investigated.

The use of natural ingredients for the manufacture of detergents is an environmentally friendly and promising trend in cosmetology. For compositions from licorice roots, pectin can be introduced as a prebiotic, thickener and complexing agent; as a natural preservative – sea salt,

citric acid and essential oils of tea tree, grapefruit, rosemary; as a flavoring – essential oils of frangipani, jasmine. Based on literature data and experiments, licorice is a promising plant for use in enclosed ecosystems. Glycyrrhizic acid from its roots can be applied in manufacture of detergents and medicines, and the aboveground part can be animal feed, which fully corresponds to the concept of natural waste-free production.

References

- Zyl, N. *Plants of Special Purpose and Their Use in EcoCosmo-House* / N. Zyl, N. Batalevich, E. Shakhno // *Non-Rocket Space Industrialization: Problems, Ideas, Projects: Collection of Articles of the II International Scientific and Technical Conference, Maryina Gorka, Jun. 21, 2019* / Astroengineering Technologies LLC; ed. A. Unitsky. – Minsk: Paradox, 2019. – P. 191–197.
- Cyclamen Exerts Cytotoxicity in Solid Tumor Cell Lines: A Step Toward New Anticancer Agents?* / M. Yildiz [et al.] // *Asian Pacific Journal of Cancer Prevention*. – 2013. – Vol. 14, iss. 10. – P. 5911–5913.
- Gnam, G. *Dubil'nyye veshchestva i dubil'nyye materialy* [Tannins and Tannin Materials] / G. Gnam; transl. ed. by Yu.S. Zalkind. – Leningrad: Nauchnoye khimiko-tekhnicheskoye izdatel'stvo, 1927. – 460 p.
- Zhivchikova, R.I. *Introduktsiya myl'nyanki lekarstvennoy Saponaria officinalis L. v Primorskoy kraye* [Introduction of Bouncing Bet Soapwort *Saponaria officinalis* L. in Primorsky Krai] / R.I. Zhivchikova, A.I. Zhivchikov // *Vestnik DVO RAN*. – 2017. – No. 3. – P. 15–21.
- Illyustrirovannyi opredelitel' rasteniy Sredney Rossii* [Illustrated Guide to Plants of Central Russia]: [in 3 vol.] / I.A. Gubanov [et al.]. – Moscow: Tovarishchestvo nauchnykh izdaniy KMK; Institut tekhnologicheskikh issledovaniy. – 2004. – Vol. 3: Pokrytosemennyye (dvudol'nyye: razdel'nolepestnyye) [Angiosperms (dicots: dioecytes)]. – 520 p.: ill.
- Hosseinzadeh, H. *Pharmacological Effects of Glycyrrhiza spp. and Its Bioactive Constituents: Update and Review* / H. Hosseinzadeh, M. Nassiri-Asl // *Phytotherapy Research*. – 2015. – Vol. 29. – P. 1868–1886.
- Rybal'chenko, A.S. *Issledovaniye ekstraktsii solodkovogo kornya* [Research of Licorice Root Extraction] / A.S. Rybal'chenko, V.P. Golitsyn, L.F. Komarova // *Khimiya rastitel'nogo syr'ya*. – 2002. – No. 4. – P. 55–59.
- Solodka golaya (solodka gladkaya, lakriil, lakrichnik) [Licorice (Liquorice)]* [Electronic resource]. – Mode of access: <http://cnshb.ru/AKDiL/0054/base/RS/000128.SHTM/>. – Date of access: 11.05.2023.
- Izucheniye i ispol'zovaniye solodki v narodnom khozyaystve SSSR* [Study and Use of Licorice in the National Economy of the USSR]: Materials of the IV Symposium, Alma-Ata, May 2–5, 1991. – Alma-Ata: Gylym, 1991. – 192 p.
- Izucheniye i podbor soleustoychivyykh sel'skokhozyaystvennykh kul'tur dlya vozdeleyvaniya na zasolonnykh pochvakh* [Study and Selection of Salt-Tolerant Crops for Cultivation on Saline Soils]. – Bishkek, 2018. – 19 p.
- Ismailov, I. *Etot mnogolikiy skifskiy koren'* [This Many-Faced Scythian Root] [Electronic resource] / I. Ismailov. – Mode of access: <https://orient.tm/ru/post/27080/etot-mnogolikij-skifskij-koren->. – Date of access: 13.05.2023.
- Ammosov, A.S. *Solodka: primeneniye v mirovoy praktike (obzor po materialam okhrannykh dokumentov za period s 1901 po 2020 gody)* [Licorice: Application in World Practice (Review by Materials of Protection Documents for the Period from 1901 to 2020)] [Electronic resource] / A.S. Ammosov, V.I. Litvinenko, T.P. Popova. – Mode of access: <https://xn----dtbhaacat8bfloi8h.xn--p1ai/licorice-application-in-world-practice-review-by-materials->. – Date of access: 15.05.2023.
- Koroleva, Yu.Ye. *Retsepturnyy sostav organicheskoy i traditsionnoy kosmetiki* [Recipe Composition of Organic and Traditional Cosmetics] / Yu.Ye. Koroleva // *Sibirskiy trgovo-ekonomicheskij zhurnal*. – 2010. – No. 10. – P. 80–82.
- Iklasova, A.Sh. *Pektin: sostav, tekhnologiya polucheniya, primeneniye v pishchevoy i farmatsevticheskoy promyshlennosti* [Pectin: Composition, Technology of Production, Application in Food and Pharmaceutical Industry] / A.Sh. Iklasova, Z.B. Sakipova, E.N. Bekbolatova // *Vestnik KazNMU*. – 2018. – No. 3. – P. 243–246.
- Khudaykulova, O.A. *Perspektivy ispol'zovaniya nizkoeterifitsirovannykh pektinovykh veshchestv v sostave kosmeticheskikh sredstv spetsial'nogo naznacheniya* [Prospects for the Use of Low-Etherified Pectin Substances in the Composition of Special-Purpose Cosmetics] [Electronic resource] / O.A. Khudaykulova // *Provizor*. – 1999. – Iss. 15–16. – Mode of access: https://www.provisor.com.ua/archive/1999/N1516/pektin.php?part_code=40&art_code=1721. – Date of access: 17.05.2023.
- Yumaguzhina, A.R. *Obshchaya kharakteristika natural'noy kosmetiki i yeyo osnovnykh komponentov* [General Characteristics of Natural Cosmetics and Its Main Components] [Electronic resource] / A.R. Yumaguzhina, Ye.A. Drozdova, Ye.S. Aleshina // *Mezhdunarodnyy studencheskiy nauchnyy vestnik*. – 2022. – No. 1. – Mode of access: <https://eduherald.ru/ru/article/view?id=20870>. – Date of access: 19.05.2023.
- Georgiyeva-Andreyeva, M. *Issledovaniye antigribnogo dey-stviya efirnykh masel chaynogo dereva (Melaleuca alternifolia), shalfeya (Salvia officinalis) i evkalipta (Eucalyptus globulus) na grib Alternaria ssp., izolirovannyi iz stevii (Stevia rebaudiana)* [Research on Antifungal Activity of Essential Oils from Tea Tree (*Melaleuca alternifolia*), Sage (*Salvia officinalis*) and Eucalyptus (*Eucalyptus globulus*) Against *Alternaria* ssp. Isolated from Stevia (*Stevia rebaudiana*)] / M. Georgiyeva-Andreyeva, S. Yenchey // *Izvestiya Timiryazevskoy sel'skokhozyaystvennoy akademii*. – 2013. – Iss. 3. – P. 132–137.
- Samusenko, A.L. *Issledovaniye antioksidantnoy aktivnosti efirnykh masel limona, rozovogo greypfruta, korianta, gvozdiki i ikh smesey metodom kapillyarnoy gazovoy khromatografii* [Study of Antioxidant Activity of Essential Oils of Lemon, Pink Grapefruit, Coriander, Clove and Their Mixtures by Capillary Gas Chromatography] / A.L. Samusenko // *Khimiya rastitel'nogo syr'ya*. – 2011. – No. 3. – P. 107–112.
- Khimicheskiy analiz lekarstvennykh rasteniy* [Chemical Analysis of Medicinal Plants]: Study Guide for Pharmaceutical Universities / Ye.Ya. Ladygina [et al.]; ed. N.I. Grinkevich, L.N. Safronich. – Moscow: Vysshaya shkola, 1983. – 176 p.

UDC 159.96:316.6

I. Budrina
Dr. of Sociological Sciences

AM Consultancy,
Bucharest, Romania

Human Mental Adaptation in the Enclosed Ecosystem Conditions: Dynamics and Stages



The issues of providing human life and maintaining their working capacity in artificial physical environments are highly relevant due to exploration of outer space and development of new technologies for these purposes. Change in the functional state of the organism in such habitable conditions increases the risk of making mistakes in professional activity causing emergencies, as well as it may harm the specialists' health and lead to their maladaptation. Learning of the human adjustment patterns to new circumstances is an essential element for prediction of their functional state during work and rest, adequate diagnostics, prevention activity and correction of the adaptation process.

Keywords:

enclosed ecosystems, mental adaptation, psychological characteristics, stages, stress.

Introduction

In accordance with the theory of adaptation, artificial conditions of life activity are considered as a set of factors responsible for the functional state of the organism. Under their influence, it redirects its activity towards optimizing the interaction in the "organism – environment" system. Mental state is one of the manifestations of the adaptation process, and its changes can be presented as psychological reactions of human adjustment.

The relevance of this topic is determined by the tasks of psychological support of professional activity of specialists in an enclosed ecosystem and the prevention of mental adaptation disorders to the new environment. As a hypothesis, it has been put forward the assumption that human habituation to life in such conditions is characterized by regular invariant stages, and the dynamics of the adaptation process depends mainly on the person's psychological attitude regarding the duration of stressful impact.

Mental Adaptation

H. Selye described the typical dynamics of responses to stress, the main task of which is to protect the organism. The scientist called the reactions, which cause a generalized, systemic protective effect, general adaptation syndrome (GAS). Although the distinction between physiological and psychological processes remains ulterior, the dynamics of GAS reactions has been widely disseminated in psychological science [1].

In the broadest sense, adaptation is understood as the process of adjustment to the surroundings through behavioral or mental changes that contribute to achieving an optimal level of functioning. Depending on the field of knowledge, the term has specific meanings: in physiology – the regulation of a bodily organ in accordance with external conditions; in evolutionary biology – the adjustment of species to the environment in which they evolve; in psychology – the process by which an individual achieves the best balance between conflicting needs [2, 3].

There is no unity in the interpretation of this concept in the psychological literature. With all the variety of classification models, three forms of human adaptation to the changing environment are distinguished: biological, social and psychological.

F. Berezin speaks about psychophysiological adaptation, or a situation when along with the maintenance of mental homeostasis proper, optimization of constant interaction of a person with the environment and establishment

of adequate correspondence between mental and physiological characteristics are provided. The researcher distinguishes the following levels of mental adaptation: psychophysiological, psychological and sociopsychological [4].

A. Maklakov discusses the complex mechanisms of physiological, mental and social adaptation, emphasizing that human is "not just a living organism but first of all a complex biosocial system" [5]. A. Morozov divides mental and psychophysiological adaptation as separate types. He describes three functional levels in the structure of this phenomenon – psychophysiological, psychological, social, which are simultaneously involved in regulatory processes [6]. V. Medvedev points to the stable interaction of physiological and psychological functions of a person [7, 8].

M. Sandomirsky identifies the following interrelated types of mental adaptation of a person, considered as components: psychophysiological adaptation, or the property of the organism to reasonably restructure physiological functions in accordance with the requirements of the environment; psychological adaptation (and specifies in the remark: or mental), violations of which are associated with tension, psychological stress; psychosocial adaptation, or adaptation of an individual to communicate with a new team. In the view of the scientist, mental adaptation includes the psychological one: "Mental adaptation is considered as a complex phenomenon that is not reduced only to psychological adaptation (in English-language literature, the term "psychological adaptation" is used as a synonym for mental adaptation) and requires for its study the consideration of both psychological and physiological parameters" [9].

Traditionally, mental and social adaptation are studied separately (as independent types). There is a possible variant when social adaptation is interpreted as sociopsychological one. Most often it is referred to mental (rather than psychological) adaptation, including sociopsychological indicators [10–12].

A. Nalchajyan studies only socio-mental adaptation of a person [13]. A. Rean considers sociopsychological adaptation as an active self-change of a person in accordance with the requirements of the situation [14].

Psychological literature mainly analyzes personal adaptation to the environment and emphasizes that it is carried out in the process of conscious operation. L. Kitaev-Smyk points out the diversity of mental and social activity (and passivity) of people under stress, considering many anthropological factors, i.e., human activity with all its properties, functions, manifestations and relationships [15].

According to A. Sukharev, mental adaptation is an active personal function that ensures the harmonization

of an individual's actual needs with the requirements of the environment and dynamic changes in living conditions [16].

In the opinion of Yu. Alexandrovsky, the leading position in the hierarchy of links of mental adaptation belongs to subsystems that provide search, perception and processing of information; emotional response, which creates, in particular, a personal attitude to the received information and is the most integrated form of activity; sociopsychological contacts [10].

In this connection, it should be added that under special variants of adaptation (in the conditions of a person's long-term stay in an enclosed environment) it is in such subsystems that changes should be expected. Disturbance of the balance in the "human – environment" system entails tension of individual's adaptive mechanisms, increase of anxiety, weakening of emotional stability, transformation of the characteristics of interpersonal and microsocial relations (i.e., relations in small groups).

Summarizing the main provisions above, Ye. Zavyalova concludes that adaptation is a personal process responsible for human interaction with the natural and social environment [17]. The system-forming factor that regulates and organizes adaptation is the goal associated with the leading need. The course of the adaptation process is influenced by the psychological properties of a human, including the level of his or her personal development, characterized by the perfection of the mechanisms of personal regulation of behavior and activity.

A. Aldasheva [18] speaks about mental adaptation of an individual and offers another important concept – "adaptive threshold". This is the smallest possible value, the minimum limit of accumulation (manifestation) of properties (qualities, resources) necessary for successful adaptation of a person. On the one hand, the adaptive threshold is set by the environment, on the other hand, the carrier of these qualities is a person who, armed with them, has to respond to the challenge.

Thus, we come to the conclusion that, despite the absence of unity in the interpretation of the definition as a whole, all researchers point to the importance of understanding the essence and structure of the adaptation process, including its psychological aspects.

Enclosed Ecosystems

The definition of an enclosed ecosystem is required to understand both the very features of a given habitat and mental adaptation within it.

An ecosystem is a form of organization of biological communities [19]. An enclosed ecosystem does not assume any exchange with the external environment. A system is called strictly enclosed, or completely enclosed, if it operates in isolation from the outside world, except for energy exchange [20].

Such systems are needed in the inevitable further development of industrial civilization, when it will become impossible to rely on the saving regulating forces of nature and it will be necessary to resort to high-tech life-support systems. Within them, the circulation of substances is created, which is required for a human being to live safely inside an enclosed space for an almost unlimited period of time. This raises the question of selection and adaptation of participants for given ecosystems, their readiness for professional work under such conditions.

In this point of view, the experience of two projects – BIOS-3 and Biosphere-2 – is worth attention. These experiments reflected the idea of complete self-sufficiency as closely as possible. The first one was 80 % isolated and lasted about 180 days, the second one was 100 % isolated and lasted two years.

The BIOS-3 system [21] was created in Krasnoyarsk, where in the early and mid-1970s many months of successful tests with people under conditions of high autonomy were conducted. Four people participated in the experiment. The team was selected according to their knowledge level, state of health, motivation. Their psychological compatibility was considered. Three participants had been living in the BIOS-3 system for up to six months, feeling themselves well. Their health was carefully monitored, including by self-measurements, which was an indicator of psychological comfort. The system had similarities to Earth's biosphere as oxygen, water and food were regenerated in it with the help of plants.

The Biosphere-2 experiment [22] was conducted in Arizona in the early 1990s and it was a failure. For the implementation, a hermetically sealed structure was built on an area of several hectares, where only sunlight penetrated to ensure photosynthesis. The amount of 3,000 flora representatives and 4,000 fauna representatives as well as eight people – four men and four women – were accommodated under a huge glass dome, where a variety of natural zones were recreated. However, due to numerous miscalculations and shortcomings, the experiment turned out to be unsuccessful: the oxygen content decreased critically, microorganisms multiplied, and the biological balance could not be established. This resulted in conflicts

between the participants, their psychological compatibility in passing through the adaptation process was not taken into account.

During the study, the team was divided into two groups that avoided each other. People did not unite, did not have a leader, everyone was engaged only in their duties. Although the medical parameters of all participants improved by the end of the experiment, they did not feel well, and this was a purely psychological factor. The mission was officially deemed a failure because of oxygen problems, pest infestations and a tense situation in the team that did not possess the required collaborative features and failed to accomplish the task.

Both experiments showed that participants of an enclosed ecosystem should be distinguished by certain social and psychological qualities and skills. It is necessary to create community and its cohesion, considering the adaptation processes of each member.

Stages and Dynamics of Mental Adaptation

Ye. Zavyalova believes that the process of human adaptation in new conditions of existence has a temporal dynamic, the stages of which are associated with certain psychological changes manifested at the level of both the condition and personal properties [17].

Regardless of the type of stress impact, H. Selye formulated general regularities of the process of adjustment to stressful events and proposed three stages: anxiety, resistance, exhaustion, as a result of which the activity of the human organism is aimed at maintaining or preserving the balance between the requirements of the environment and the resources satisfying them [1].

Modern theories of adaptation suggest 4–5 stages, indicating more detailed psychological characteristics necessary to be considered when building a team of an enclosed ecosystem.

The process of human adjustment to an enclosed ecosystem can be compared to getting used to a new culture. Such adaptation is reflected in the studies devoted to the symptomatology of cultural shock in temporary settlers and migrants, strategies for overcoming it as well as theories of stages of cross-cultural adaptation.

One of the most well-known models is the cultural shock one, which was developed by anthropologist K. Oberg [23]. He analyzed in detail four stages of adaptation: honeymoon, crisis, recovery and adaptation (as opposed to H. Selye's three stages).

The term "cultural shock", introduced by K. Oberg, meant entering a new culture, a new environment and was determined by negative feelings (change of social and public position), which led to insecurity, anxiety, irritability, insomnia, psychological disorders, depression.

According to Y. Kim, during a favorable integration into a new culture, an individual goes through the cycle of "stress – adaptation – personal growth". Here the tendency follows from enthusiasm and high spirits to depression and confusion and then to a feeling of confidence and satisfaction [24].

Describing the stages of mental adaptation, A. Alyokhin, Ye. Dubinina and K. Pultsina suggest relying on the concept of experiencing [25].

S. Rubinstein defines experiencing as a unique event in the individual history of person's development; considers it as a dynamic unit of consciousness, represented in the affective and intellectual unity [26]. F. Vasilyuk analyzes the experiencing from the position of the activity approach – as a process of overcoming suffering, transforming the psychological situation, and a special form of the person's activity to restore psychological balance [27].

The concept of experiencing is very promising for designating the psychological aspect of adaptation, namely, the process reflecting the mental (cognitive-affective-behavioral) pattern of a person's response when mastering a new (stressful) experience, in our case in an enclosed ecosystem. This process is initiated by the misalignment of the existing experience and behavior with the actual situation. It includes psychological mechanisms of assimilation and accommodation, the direction and dynamics of which are set by the needs of an individual in an enclosed ecosystem, where the main stressors are physical factors of artificial habitat, hypodynamia, monotony, relative sensory and social isolation, modeled professional activity and interpersonal relations in a group.

A. Alyokhin [28] and other scientists point to the fact that, regardless of the duration of stay and external factors, four qualitatively distinct stages and two transient adaptation processes are always clearly distinguished phenomenologically. The stability of the state decreases at the beginning of the trial, then increases to some extent, again decreases, then increases and holds at an acceptable level but again falls sharply in anticipation of the end of the stay. The authors cite the following characteristics of these stages.

1. The first phase is the beginning (initialization) of experiencing – the collision of formed mindsets, perceptions, ways of reacting with new conditions of life activity. At this stage,

habitual psychological attitudes and relationships of the individual are violated, which is accompanied by nonspecific tension and affects the course of almost all mental processes.

There takes place an intensification of the self-relationship system. This period is also characterized by emotionally distressing experience of the feeling of unfreedom, environmental pressure with a paradoxical sense of time: on the one hand, it drags slowly, and on the other hand, it is looming over the person with a distressing and disturbing uncertainty of the future. All the abovementioned affects the stability index, which reflects the general mental destabilization.

2. The second phase is featured by increased differentiation or dissociation of external and internal activities, attempts to implement new ways of behavior and response. The emphasis from the self shifts to interpersonal relations, the tension of tendencies to both assimilation and accommodation is seen. Here we observe an increased interpersonal conflict, unstable pattern of behavior, certain inconsistency of reactions, thoughts and feelings, which is associated with the uneven assimilation of the acquired experience. There is an aggravation of existing interpersonal conflicts or the emergence of new ones. At the same time, the indicators of activity adaptability and productivity are significantly reduced.

The awareness of one's psychological loneliness at this stage indicates the crisis of both interpersonal relations proper and his or her concepts, which actually forces the individual to move from the world of subjective ideas and representations to the world of reality.

3. The third phase is characterized by the actualization of relations with the objective and concrete event reality (with an enclosed ecosystem), which provides the possibility of conflict-free discharge of emotional tension, preoccupation with the activity itself rather than with social assessments and, as a consequence, increased work efficiency and growth of information-seeking activity. At this stage, the transformation of personal attitudes in accordance with the requirements of the environment (enclosed ecosystem) is noted, and stabilization of the condition is achieved.

4. The final fourth phase assumes a new shift of activity to the self-relations sphere. The essence of the period lies in the contradiction or dissociation between the already established forms of behavior and attitudes, on the one hand, and expectations, the image of the near future, on the other hand.

This stage is distinguished by the presence in the experience of models of adequate behavior and communication.

Self-assessment becomes closer to the objective one. There appears some excitement in the emotional sphere. The state of fatigue is also characteristic, which is experienced at this stage as a deficit of relations, i.e., there is no substrate for information-seeking engagement, therefore, as in the first periods, the activity is switched over to the inner world and is connected with psychological designing of the future, which again leads the individual away from the objective-real world to the subjective world of ideas and, accordingly, to another decrease in the indicators of general adaptability.

It should be noted that the described stages of experiencing are observed under any unfamiliar (changed) conditions of human's life activity, in which the correspondence between his or her mental characteristics and the requirements of the environment is disturbed.

V. Lebedev's experience in the field of extreme psychology is interesting and useful from a scientific point of view. Based on his own practice and analysis of literary sources, the scientist offers the following periodization of mental adaptation and maladaptation under altered conditions of existence [29].

1. Preparatory stage. It is cognitive in nature. A certain stock of information about the environment and conditions of activity is accumulated, and an information field is formed, which will be one of the sources of action of the adaptation mechanism.

2. A stage of starting mental tension. It can be considered as a launching moment. The substantive, functional and semantic sides of this period consist in the growth of emotional experiencing, forming the feeling of tension and being, in fact, psychophysiological determinants of activation of any living organism. There takes place an internal mobilization of human mental resources for their subsequent use in order to arrange a new level of mental activity under altered conditions of existence.

3. A stage of acute mental reactions of entry, or primary maladaptation. It is considered a period of the adaptation process, at which the individual begins to experience the influence of psychogenic factors of changed existence. The main of such factors are altered afferentation (abrupt change of a stimuli set that acted on the sense organs and a person's psyche earlier) and monotony (absence of any habitual stimuli or their monotony for quite a long time).

A relative group isolation – a forced disconnection of an individual from a large number of habitual and necessary communicative associations due to his or her needs

and limitation of the person's social network within a new environment; it implies informational exhaustion of members of a given group in relation to each other, which also causes emotional tension.

Primary maladaptation determines two possible ways of development of the adaptation process: the stage of mental readaptation, or transition to a state of stable adaptation to conditions, and the stage of unstable mental activity, which in turn can lead to severe mental changes.

4. A stage of final mental tension. It occurs when the adaptation process develops in a favorable direction. The distinctive content of this period is a peculiar preparation of the human psyche for the return, to some extent, of old modes of functioning and reactions as well as for the conditions modeled anew by the consciousness of the individual.

Particular attention is drawn to the individual's high involvement in experiencing associated with the upcoming and long-awaited return to familiar life. There appears an interest to affairs that can have a pronounced nature and occupy all the free time. This is explained by the fact that the newly arisen tension, having activated the psyche, thus compensates for the excess of mental energy caused by it.

5. A stage of acute mental reactions of exit. In its functional significance it is to some extent similar to the period of entry reactions, since any changes in the conditions of life, activity and environment imply a restructuring of the complex of mental reactions and all mental processes.

It implies a solution that a person has been in for a long time during a period of life. However, it should be noted that the circumstances awaiting him or her are not always identical to those, in which he or she was before the change. This is also largely due to the changes in the personality structure that have occurred at this phase. The stage is characterized by behavioral reactions, in which euphoria, the feeling of overcoming many social restrictions, supposedly complete freedom and unlimited opportunities in meeting needs are manifested. These feelings can often be deceptive and lead to undesirable consequences when many norms are denied.

6. Afteradaptation. It is marked by the formation of other patterns of behavior necessary for the new living environment.

So, it is seen that, despite the differences in the details of describing the stages of mental adaptation, the process itself is recognized by all researchers. If it proceeds successfully, there comes a feeling of psychological well-being

and peace of mind. The degree of manifestation of the phases and the duration of adaptation are determined by the individual's features. The following properties should be taken into account thereby:

- individual differences – demographic and personal: according to a number of researchers, highly intelligent and highly educated people adapt more quickly and easily; women experience more problems during this period than men;

- readiness for changes: those who have an experience of migration more often perceive changes in the environment quite well, as they are motivated to adapt (achieve the set goal) and prepare for the perception of a new culture in advance;

- individual experience of living through stressful and extreme situations.

The selection of team members of enclosed ecosystems requires the creation of a test suits that allow to perform differentiation in conformance with the necessary set of qualities and skills as well as to conduct trainings for preliminary informational preparation of participants. At all adaptation stages, it is important to provide a psychological support to the group in order to minimize the impact of consequences on the mental state of its members.

The following criteria can serve as a reference point for the creation of such a program: a person's ability to find a place in the socio-professional structure, to develop in accordance with his or her potential of life activity, overall health, subjective sense of self-esteem, emotional literacy in the form of analysis of one's own experiencing as a psychological aspect of adaptation and regulation, which will allow, on the one hand, to identify the universality in behavior under stress and, on the other hand, the uniqueness related to experience, system of relations, individual senses of a particular person.

The most stress-resistant people are those who perceive the world as meaningful and manageable. They have a sense of coherence [30], connectedness, when emerging threats are perceived as challenges that bring about new opportunities, as well as the ability to assess soundly their own resources needed to solve the next tasks. It is such an attitude that ensures mental health.

If we are talking about an enclosed space with a limited social circle, as in the case with enclosed ecosystems, then creating a friendly atmosphere and selecting participants with the appropriate character traits are among the factors that determine the success of the entire project and, subsequently, of the entire space exploration mission.

Conclusion

Based on the above studies, we can conclude that the dynamics of mental adaptation to the conditions of an artificial ecosystem, i.e., to an unfamiliar living environment, consists in a regular change of stabilization and destabilization stages.

Destabilization is manifested by an increase in anxiety and activation caused by the need to transform patterns of behavior to achieve adaptation to a new way of life, to optimize functioning under altered circumstances. Stabilization is characterized by the return of mental and psychophysiological parameters to the level of dynamic homeostasis and the formation of behavior patterns adequate to the enclosed environment. Achievement of this stage is realized either through the return to the background mental and psychophysiological indicators or through the formation of a new functional state.

The dynamics of mental adaptation to the conditions of an artificial ecosystem does not depend on the duration of the individual's stay in it but is determined by his or her psychological attitude to the expected duration of stay. Participants of enclosed ecosystems should be selected individually through specialized tests and trainings, considering personal characteristics: emotional intelligence, motivation and psychological compatibility.

References

1. Sel'ye, G. *Ocherki ob adaptatsionnom syndrome [Essays on Adaptation Syndrome]* / G. Sel'ye; transl. from English V.I. Kandror, A.A. Rogov; ed. M.G. Durmish'yan. – Moscow: Medgiz, 1960. – 254 p.
2. Yanchuk, V.A. *Chetyrokhmernyy kontinuum ponimaniya fenomenologii biopsikhosotsial'noy adaptatsii: sotsiokul'turno-interdeterministskaya dialogicheskaya perspektiva [A Four-Dimensional Continuum of Understanding the Phenomenology of Biopsychosocial Adaptation: A Sociocultural-Interdeterministic Dialogical Perspective]* / V.A. Yanchuk // *Psikhosotsial'naya adaptatsiya v transformiruyushchetsya obshchestve: sotsializatsiya sub'yekta na raznykh etapakh ontogeneza: Materials of the IV International Scientific Conference, Minsk, May 21-22, 2015* / ed. I.A. Furmanov [et al.]. – Minsk: Izdatel'skiy tsentr BGU, 2015. – P. 530–536.
3. Yanchuk, V.A. *Metodologo-psikhologicheskiye osnovaniya problemy adaptatsii: ot opisaniya k ponimaniyu [Methodological and Psychological Foundations of the Problem*

of Adaptation: From Description to Understanding] / V.A. Yanchuk // *Psikhosotsial'naya adaptatsiya v transformiruyushchetsya obshchestve: problemy i perspektivy: Materials of the II International Scientific Conference, Minsk, Oct. 26, 2007* / ed. I.A. Furmanov [et al.]. – Minsk: Izdatel'skiy tsentr BGU, 2007.

4. Berezin, F.B. *Psikhicheskaya i psikhofiziologicheskaya adaptatsiya cheloveka [Mental and Psychophysiological Adaptation of a Person]* / F.B. Berezin. – Leningrad: Nauka, 1988. – 270 p.
5. Maklakov, A.G. *Lichnostnyy adaptatsionnyy potentsial: yego mobilizatsiya i prognozirovaniye v ekstremal'nykh usloviyakh [Personal Adaptive Potential: Its Mobilization and Forecasting in Extreme Conditions]* / A.G. Maklakov // *Psikhologicheskii zhurnal*. – 2001. – Vol. 22, No 1. – P. 16–24.
6. Morozov, A.V. *Problemy sotsial'no-psikhologicheskoy adaptatsii [Problems of Sociopsychological Adaptation]* [Electronic resource] / A.V. Morozov. – Mode of access: <https://referat.co/ref/157082/read?p=1>. – Date of access: 29.06.2023.
7. Medvedev, V.I. *O probleme adaptatsii [On the Problem of Adaptation]* / V.I. Medvedev // *Komponenty adaptatsionnogo protsessa* / ed. V.I. Medvedev. – Leningrad: Nauka, 1984. – P. 3–16.
8. Medvedev, V.I. *Ustoychivost' fiziologicheskikh i psikhologicheskikh funktsiy cheloveka pri deystvii ekstremal'nykh faktorov [Stability of Human Physiological and Psychological Functions Under the Impact of Extreme Factors]* / V.I. Medvedev. – Leningrad: Nauka, 1982. – 104 p.
9. Sandomirskiy, M.Ye. *Sostoyaniye psikhicheskoy adaptatsii v usloviyakh khronicheskogo psikhoemotsional'nogo stressa v svyazi s lichnostno-tipologicheskimi kharakteristikami [State of Mental Adaptation in Conditions of Chronic Psychoemotional Stress in Connection with Personality-Typological Characteristics]: Ph.D. Med. Sc. Diss. Abstr.: 14.00.18* / M.Ye. Sandomirskiy; Russian State Medical University. – Orenburg, 2001. – 28 p.
10. Aleksandrovskiy, Yu.A. *Sostoyaniya psikhicheskoy deadaptatsii i ikh kompensatsiya [States of Mental Maladaptation and Their Compensation]* / Yu.A. Aleksandrovskiy. – Moscow: Nauka, 1976. – 272 p.
11. Alokhin, A.N. *Adaptatsiya kak kontsept v mediko-psikhologicheskoy issledovani [Adaptation as a Concept in Medical and Psychological Research]* / A.N. Alokhin // *Anniversary Collection of Scientific Papers [To the 10th Anniversary of the Department of Clinical Psychology of Herzen State*

- Pedagogical University of Russia*. – Saint Petersburg: *Strategiya budushchego*, 2010. – P. 27–32.
12. Vasserman, L.I. *Sovladaniye so stressom: teoriya i psikhodiagnostika [Coping with Stress: Theory and Psychodiagnosics]: Study and Methodological Guide / L.I. Vasserman, V.A. Ababkov, Ye.A. Trifonova*. – Saint Petersburg: *Rech'*, 2010. – 192 p.
 13. Nalchadzhyan, A.A. *Sotsial'no-psikhicheskaya adaptatsiya lichnosti (formy, mekhanizmy i strategii) [Socio-Mental Adaptation of Personality (Forms, Mechanisms and Strategies)] / A.A. Nalchadzhyan*. – Yerevan: *Izdatel'stvo AN ArmSSR*, 1988. – 263 p.
 14. Rean, A.A. *Psikhologiya adaptatsii lichnosti. Analiz. Teoriya. Praktika [Psychology of Personality Adaptation. Analysis. Theory. Practice] / A.A. Rean, A.R. Kudashev, A.A. Baranov*. – Saint Petersburg: *Praym-YEVROZNAK*, 2006. – 479, [1] p.
 15. Kitayev-Smyk, L.A. *Psikhologiya stressa. Psikhologicheskaya antropologiya stressa [Psychology of Stress. Psychological Anthropology of Stress] / L.A. Kitayev-Smyk*. – Moscow: *Akademicheskii projekt*, 2009. – 943 p.
 16. Sukharev, A.V. *Psikhologicheskiiy etnofunksional'nyy podkhod k psikhicheskoy adaptatsii cheloveka [Psychological Ethnofunctional Approach to Human Mental Adaptation]: Dr. Psych. Sc. Diss.: 19.00.01 / A.V. Sukharev*. – Moscow, 1998. – 352 p.
 17. Zav'yalova, Ye.K. *Psikhologicheskiye mekhanizmy sotsial'noy adaptatsii cheloveka [Psychological Mechanisms of Human Social Adaptation] / Ye.K. Zav'yalova // Vestnik Baltiyskoy pedagogicheskoy akademii*. – 2001. – Iss. 40, No. 4. – P. 55–60.
 18. Aldasheva, A.A. *Osobennosti lichnostnoy adaptatsii v малыkh izolirovannykh kolektivakh [Features of Personal Adaptation in Small Isolated Groups]: Ph.D. Psych. Sc. Diss.: 19.00.01 / A.A. Aldasheva; Institute of Experimental Medicine of the USSR Academy of Medical Sciences [et al.]*. – Leningrad, 1984. – 19 p.
 19. Pereslegin, S.B. *O mekhanike tsivilizatsiy [On the Mechanics of Civilizations] / S.B. Pereslegin, A.M. Stolyarov, N.Yu. Yutanov // Nauka i tekhnologiya v Rossii*. – 2002. – No. 1 [52]. – P. 23–28.
 20. Khlebopros, R.G. *Zamknutyie ekologicheskkiye sistemy i zemnaya biosfera [Enclosed Ecological Systems and Terrestrial Biosphere] [Electronic resource] / R.G. Khlebopros, V.A. Okhonin, A.I. Fet*. – Mode of access: <https://www.modernproblems.org.ru/science/141-catast2.html?start=3#content>. – Date of access: 15.06.2023.
 21. *Nauchno-issledovatel'skiy kompleks "Zamknutyie ekosistemy" [Research Complex "Enclosed Ecosystems"] [Electronic resource]*. – Mode of access: <http://www.ibp.ru/ecosystem/info01.php>. – Date of access: 30.06.2023.
 22. *Biosphere 2 [Electronic resource]*. – Mode of access: <https://ecotechnics.edu/projects/biosphere-2/>. – Date of access: 29.06.2023.
 23. Oberg, K. *Cultural Shock: Adjustment to New Cultural Environments // Practical Anthropology*. – 1960. – No. 7. – P. 177–182.
 24. Kim, Y.Y. *Adapting to a New Culture: An Integrative Communication Theory / Y.Y. Kim // Theorizing About Intercultural Communication / ed. W.B. Gudykunst*. – California: *Sage Publications*, 2005. – P. 375–400.
 25. Alokhin, A.N. *Perezhivaniye kak psikhologicheskiiy aspekt adaptatsii cheloveka v neprivychnykh usloviyakh zhiznedeyatel'nosti [Experiencing as a Psychological Aspect of Human Adaptation in Unfamiliar Living Conditions] [Electronic resource] / A.N. Alokhin, Ye.A. Dubinina, K.I. Pul'tsina // Meditsinskaya psikhologiya v Rossii*. – 2014. – No. 5 [28]. – Mode of access: http://mprj.ru/archiv_global/2014_5_28/nomer/nomer03.php. – Date of access: 12.06.2023.
 26. Rubinshteyn, S.L. *Osnovy obshchey psikhologii [Fundamentals of General Psychology] / S.L. Rubinshteyn*. – 2nd ed. – Saint Petersburg: *Piter*, 2002. – 720 p.
 27. Vasilyuk, F.Ye. *Psikhologiya perezhivaniya. Analiz preodoleniya kriticheskikh situatsiy [Psychology of Experiencing. Analysis of Overcoming Critical Situations] / F.Ye. Vasilyuk*. – Moscow: *Izdatel'stvo Moskovskogo universiteta*, 1984. – 200 p.
 28. Alokhin, A.N. *Etapy psikhicheskoy adaptatsii cheloveka k ekstremal'nyim usloviyam professional'noy deyatel'nosti [Stages of Human Mental Adaptation to Extreme Conditions of Professional Activity] / A.N. Alokhin // Mediko-biologicheskkiye i sotsial'no-psikhologicheskkiye problemy bezopasnosti v chrezvychaynykh situatsiyakh*. – 2009. – No. 3. – P. 76–81.
 29. Lebedev, V.I. *Etapy psikhicheskoy adaptatsii v izmenonnykh usloviyakh sushchestvovaniya [Stages of Mental Adaptation in Altered Conditions of Existence] / V.I. Lebedev // Voprosy psikhologii*. – 1980. – No. 4. – P. 50–60.
 30. Osin, Ye.N. *Chuvstvo svyazannosti kak pokazatel' psikhologicheskogo zdorov'ya i yego diagnostika [Sense of Coherence as an Indicator of Psychological Health and Its Diagnostics] / Ye.N. Osin // Psikhologicheskaya diagnostika*. – 2007. – No. 3. – P. 22–40.



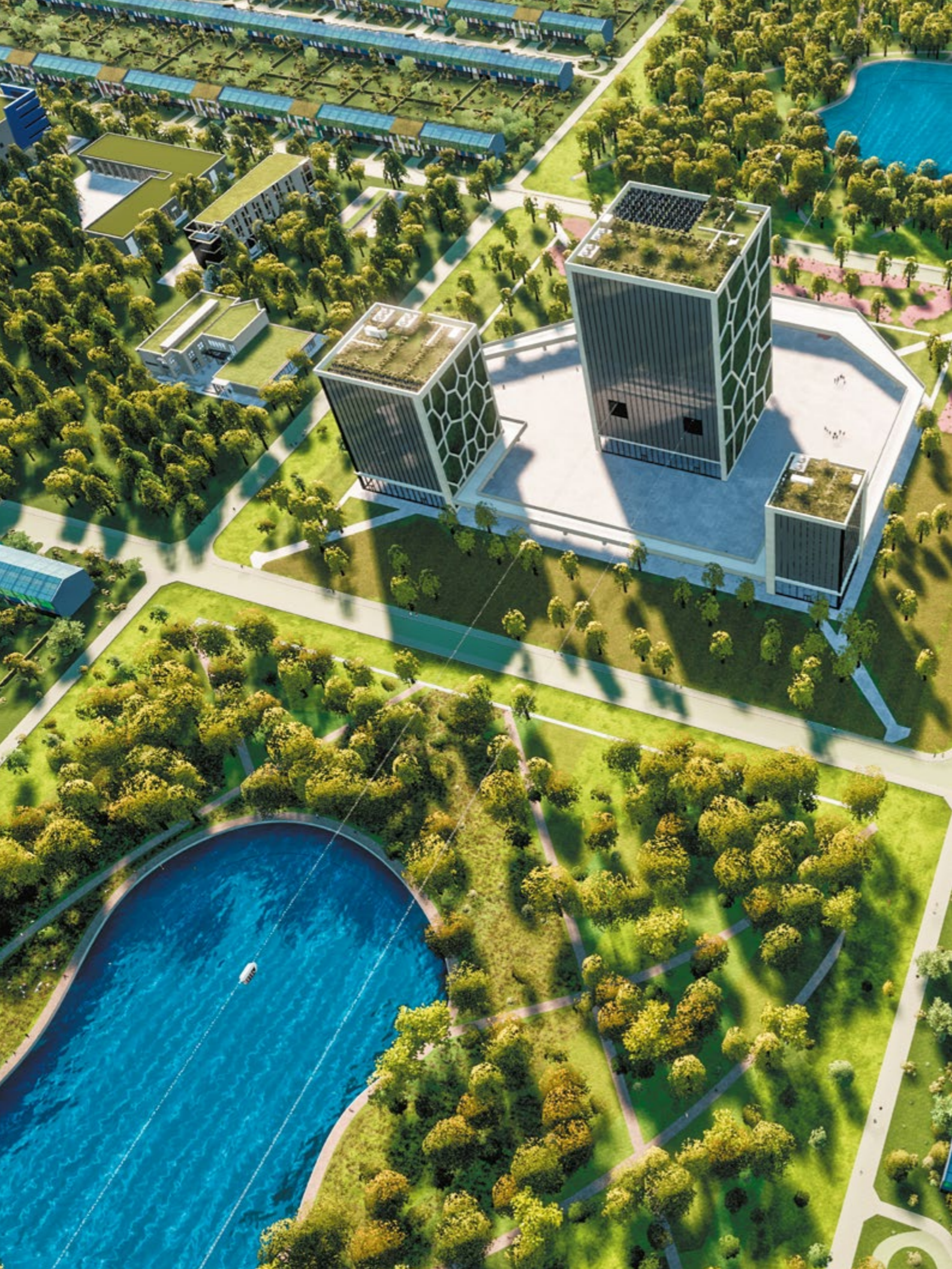

UDC 711.416-122+316.023:316.34

Structure of the Social Space of a New Type of Living Environment: Prerequisites, Development, Stratification

A. Unitsky^{1,2}
Dr. of Philosophy
in Information Technologies
(Transport)

M. Davydik²

¹ Astroengineering Technologies LLC,
Minsk, Belarus

² Unitsky String Technologies Inc.,
Minsk, Belarus



The issues of organizing the optimal social structure of a new type of settlement – a residential cluster in the linear cities (uCities) – are considered. The historical prerequisites for the emergence and development of utopian ideas of an ideal society are determined. The attempts to harmonize social relations that were undertaken throughout the 19th and 20th centuries are studied. The thesis about the inextricable connection between the structure of society and its impact on the Earth's biosphere is revealed. The conditions for creating viable social structures and their spatial implementation are described. The features of social stratification of a new type of living environment are named. The optimal social structure – uSocio – is proposed.

Keywords:

linear type of settlement, new type of residential environment, residential cluster, social space, social stratification, society's quality of life, uCity, Unitsky String Technologies (uST), uSocio.

Introduction

The technological progress of modern society, observed in the present period, in itself is not considered as a guarantee of improving the quality of people's lives. The social world, which is a multidimensional space, is a complex system that requires a differentiated approach to each of its parts. The originality of the task being solved in the study is to determine the harmonious combination of the social component and the conglomerate of planning elements of new type settlements. The dissection of the social environment into structural parts (constructive social stratification), occupying a position in a particular point of space, makes it possible to find and evaluate the status positions of social agents.

Social stratification is a phenomenon that is traditionally understood as the division of people into different strata, groups, classes, ethnic groups and similar elements based on income, education, status, possession of power, religion, lifestyle or other distinguishing features. It is undoubtedly present in any society to a greater or lesser extent depending on the objective situation as well as on its subjective vision and assessment by various participants of social processes. The purpose of this study is to identify possible structures of a constructive social stratification (uSocio) as an organizing principle of the social environment of the linear cities (uCities) residential clusters.

New type settlements are based on the concept of autonomous existence and imply not only self-sufficiency in all types of food and energy resources but also the appropriate functional, social, political and cultural organization of space [1, 2]. Life cycle management of the uCity clusters should be based on the interests of individuals and groups populating them as well as take into account the dynamics of constantly changing positions of social stratification. While architectural and planning solutions here provide wide opportunities for structuring the residential space for people's self-realization, they can also be sensitive to the requirements of the society that makes up the public environment.

Since there are different approaches to studying the dynamics of positions on traditional scales of social stratification, let us limit ourselves by focusing on two variables:

- worldview, which has a determining subjective significance for individuals (or groups);
- lifestyle, which consists of cultural and symbolic characteristics that allow people to identify themselves in a certain social group [3].

It is human with his ideas of a harmonious and happy life who is the goal and mean of any socially directed initiative.

Ideal Society as a Worldview of a Desirable Future

The desire to establish life in the best (ideal) way in near future by comparison with the nonideal (but real) present has occupied the minds of thinkers throughout the entire history of human civilization. Humans, unlike animals, are endowed with a unique tool – imagination. Before creating anything, they generate an image of the future creation (create a picture) in their minds. Significant social shifts occur as a result of translating the worldview of some part of society into tangible consequences. From Antiquity with the teachings of Plato to the time of the industrial revolution that gave rise to utopian ideas of social organization, people searched for and, as it seemed to them, found the necessary forms of social structure. The imaginary worldview, becoming a tangible reality, changed the natural environment surrounding them. The experience of stratification of society in the recent past, which showed certain social characteristics, is interesting for the research and the knowledge of relevance of the problem under consideration.

The modernity in Europe in the 17th–19th centuries, which gave birth to industrial society, proposed a social structure corresponding to it. French philosopher M. Foucault defined it by the term "disciplinary society". His book "Discipline and Punish: The Birth of the Prison" speaks on two registers, in which "the great book of Man-the-Machine" was created: "the anatomico-metaphysical register, of which Descartes wrote the first pages and which the physicians and philosophers continued, and the technico-political register, which was constituted by a whole set of regulations and by empirical and calculated methods relating to the army, the school and the hospital..." [4]. The disciplinary society has replaced the authoritative societies having been focused on collecting taxes (instead of organizing production) and reigning over death (instead of administering life).

The disciplinary society, having reached its heyday by the beginning of the 20th century, is also characterized by the time of great ideas, global projects that turned out to be a failure. Neither anarchism, nor fascism, nor communism, which proposed to subordinate the emerging reality of spontaneous social nature and the space of free ideas

to utopian forms of effective governance, could not achieve any sustainable result in this case [5], possible only through a change in civilizational approaches.

One of the attempts to implement such a method in the structuring of society is the residential environment project proposed by the NER group created at the turn of the 1960s [6]. Its name is an abbreviation of the concept "new element of resettlement", which implies a kind of matrix. Its detailed description was published in 1966 in the book "New Element of Resettlement. On the Way to a New City" [7].

The main idea of this project is based on the structuring of residential spaces within linear systems. The population of the NER (settlement matrix), acting as a residential cluster that is strung on the linear structure of a transport channel, was calculated by the authors of the concept because of the need to create a residential formation that would be optimal in terms of the number of elements, in which harmonious social relations are generated in the zone of public attraction, where there are opportunities for communication in interest groups in the so-called developed center of cultural amateur activities. According to NER members' calculations, it is the 100-thousand population of the cluster, including 60,000 adults, that is "the minimum social base for a full-fledged life of a club of interests" [7]. This was an attempt to propose a settlement system in the paradigm of modernity on a national and, even more broadly, planetary scale for a postindustrial society of NON-consumption. The participants of the NER project, who lived in a Soviet country, aimed to find a settlement structure that would create "a world belonging to all and everyone, a world filled with logic and respect for the individual" [6]. This interesting but in many ways controversial attempt of a universal solution to social problems remained unclaimed.

The modernity, which is receding into the background, is now giving way to a postindustrial society, or postmodernity. Philosophers G. Deleuze and M. Foucault call the coming structure the "society of control" [8, 9], where freedom of movement and decision making is compensated by a constant surveillance over the society through various systems of surveillance and identification. Moreover, interference in human nature through extraordinary pharmaceutical products, molecular engineering and genetic manipulation complements the control mechanisms. Unlike the disciplinary society, where the internment of an individual in the spaces of confinement through which he or she passes is based on essentially different models, each time

implying that we start the movement as if from scratch, the society of control is based on variations of a single structure, which creates a variable geometry whose language is essentially digital. It generates modulations of a single substance, similar to a molten substance that continuously flows from one form to another.

The Japanese model of collective capitalism can be considered as an illustration of this thesis. Capital in such a model is freely concentrated in the hands of a certain number of corporations closely cooperating with the government machinery. The corporation in this role acts not just as an employer but as the foundation of life. The individual becomes totally subjected to enterprise as part of the social system. It guarantees all material benefits, while the employee is required to fully submit his or her consciousness and personal space to the control of the corporation, even up to the choice of sexual partner.

Such practices are also introduced in transnational companies. It is especially evident in the imposition of the so-called corporate spirit, rigid hierarchy and conditions of career growth [8]. The corporation offers personal rivalry as the healthiest form of motivation, opposing one individual to another. It manages people through this separateness, up to the point of dividing each person within himself.

The modulation principle, which asserts that wages depend on merit, has also affected national education. As the corporation replaces the factory, continuous training replaces the school, and continuous supervision replaces one-time examinations [9]. The modern technological progress, which provides false freedom of choice, in fact carries the danger of its total suppression and manipulation of the individual's consciousness and even the society's one in its entirety.

In addition to social constraints, there are also more significant physical constraints in creating an ideal society. The planet Earth is a finite physical body. The amount of matter on it is also finite. All the substances of the biosphere during the existence of the planet should have been fully utilized by living organisms, fully bonded in dead organic bodies, fully transformed into the inert matter. But this does not happen because the animal and plant worlds are divided into trophic levels: producers, consumers and decomposers [10, 11]. The only way to attribute the properties of the infinite to something finite is to involve it in circulation. In fact, all substances on the surface and even in the depths of our planet are in the process of biogeochemical cycles [12, 13].

With all its technological infrastructure, the current civilization as well as any future one will not solve the problem of organizing ideal social and societal relations, if it does not realize a simple principle: what is established by nature should not be changed but taken into account at any innovations. A different option brings us closer to the so-called point of no return, when it will be not only difficult but, most likely, impossible to stop the destructive processes of planetary scale that are already visible today [1]. Here it is appropriate to recall the statement of the American ecologist T. Miller, who said that, according to the first law of thermodynamics, we cannot get something out of nothing; and according to the second law of thermodynamics, virtually every action we take has some undesirable effect on the environment. As a consequence, there is not the slightest possibility of a technological solution to the problem of pollution and environmental degradation, although the use of appropriate forms of technology can contribute to solving the problem [14]. In this light, the research will be continued.

Structure of Society and Its Impact on the Earth's Biosphere

The global ecological crisis, which became the reality in the second half of the 20th century, testifies to the systemic contradiction between the living biological environment (biosphere) and the artificially created technical environment (technosphere). In essence, they are antagonists. Their opposition is fixed both in obvious environmental problems and in not so obvious properties related to the stability of natural and artificial systems. The natural system (biosphere) is a structure of colossal complexity and stability with a huge number of links between its elements. The risk of imbalance and failure of technogenic systems with inevitable catastrophic consequences rises in the artificially created technosphere with its increasing complexity [13].

People settlement on Earth throughout the history of their existence took place within the framework of constantly transforming social structures of civilizational communities. The construction of settlements, roads, irrigation structures, dams and dikes, the clearing of fields from wild vegetation for the cultivation of agricultural plants, the breeding of domestic animals, the industrial development of natural resources and other interventions have significantly altered the natural landscapes of the planet and suppressed numerous forms of life on them.

The famous historian, geographer and ethnologist L. Gumilev expressed the problem of the society's impact on the living natural environment as follows: "So, the anthroposphere occupies an intermediate position between the dead technosphere and living nature" [15]. Soviet and Russian physicogeographer Yu. Efremov in his assessment of the noosphere, which he called sociosphere, expressed doubts about the rationality of the sphere of mind and defined it as destructive for the biosphere, because the development of the sociosphere leads to the replacement of living processes that enriched our planet with condensed energy reserves, gave us an oxygen atmosphere and the ozone layer that saves us from the killing cosmic radiations, with dead inert structures that degrade relatively slowly. The prospect of seeing piles of waste and concreted sites in place of forests and steppes cannot inspire the society to a productive and safe life [16].

The authors of this research believe that there is a solution of the global environmental, political and social crisis. Possessing not only mind but also intelligence, a person is able to structure society and its life processes at a high spiritual level. A. Unitsky's work "Civilization Capacity of the Space Home Named Planet Earth" indicates that the main causes of global problems of our time lie in the human activity when making rational decisions in terms of providing food, continuation of the species, other bodily needs (in the paradigm of the mind), while it is necessary to act in terms of improving one's relations with other people, the environment and the Universe as a whole (in the paradigm of intelligence) [1].

Lifestyle and Conditions for Harmonious Structuring of Society

We will substantiate the role of lifestyle, consisting of cultural and symbolic characteristics, in order to see in it the prerequisites for constructive stratification of society and self-identification of each individual in a definite social group.

The lifestyle of a person affects his or her well-being and that of his or her immediate circle of relatives and friends; the lifestyle of a certain society determines not only the well-being of the countries and nations nearest to it but also the state of the environment, both locally and globally. Relationships between individuals, social groups and communities will, in turn, become harmonious or affected by destructive impacts depending on the extent to which people are able to participate in the life of communities and the extent

to which the latter will contribute to the growth of their well-being and individual capabilities. Such prospects are determined by the concept of social quality, which examines the relationships and processes within a society and is based on the determination (measurement) of the quality of everyday life in terms of social content. This concept fixes the contours of the space where people can participate in the economic, social and other spheres of society's functioning in the conditions that contribute to the improvement of their well-being level and the fullest development of each individual's potential [17].

Within the framework of the social quality model, there are four areas of research and, accordingly, four spheres in relation to which the social quality is considered as economic security, social cohesion, social involvement, empowerment and opportunities of citizens [17]. Social movements of the past times, social shifts and conflicts generated by them are largely based on changes in these components of social life. The current century is characterized by significant movements of masses of emigrants from the countries with low social quality to the states where the standard of living is much higher than the one in which they were born and grew up. People oriented to emigration feel the need not only to improve economic conditions but also to partially change the model of the society development. Such an updated model opens prospects for the full integration of citizens into the social system and their participation in the processes of developing new agendas for the development of society. In its formation, it is justified to use methodological concepts created by modern science, concepts that are allowing to study social dynamics and changes in the life quality indicators. Without taking this into account, one can draw up plans for innovation or modernization in any amount, but if the social state policy ignores people's ideas about the proper functioning of the existing society, no breakthrough will occur, and young people in countries with a low index of social quality will continue to experience negative attitudes and will be oriented towards going abroad, prioritizing the change of place of residence when choosing a life strategy [18].

The modern society is the result of integration and interaction of fundamentally different-level orders: social (the level of individuals and interpersonal relationships) and systemic ones (the level of social institutions) [19]. The authors of the concept of uCity residential environment propose to meaningfully introduce the cluster method of organization of residential areas into the practice of project-designing

and construction. The linear type of settlement on the basis of high-speed transport and infrastructure solutions by Unitsky String Technologies (uST) will make it possible to create a residential, cultural, educational, industrial and other public environment taking into account social stratification in its constructive sense – the uSocio social environment. The cluster approach to the development of new and reorganization of established territories opens up wide opportunities for building settlements that are limited in size and configured according to the interests of different social groups. In the uCities all conditions are created for compact cohabitation with people close in spirit and interests, as well as convenient transportation and information communications with any region of the world are provided.

Optimal Social Structure of the uSocio

Since the main city-forming force is directly a person with his or her interests and needs, our attention to this topic is focused on the relevant parameters of social organization. As mentioned above, social quality is determined by the degree of people's participation in the life of communities on conditions that contribute to the growth of their well-being and individual capabilities. Modern human, tired of the constant pressure from the authorities, politicians, businesses and advertising, vitally needs a kind of outlet: understanding, solidarity, sense of community and self-actualization.

The authors realize that the social world is multivariant. The principle of cluster development of residential space in uCities is based on this understanding. Settlement of residential groups limited in number allows to achieve an unlimited variety of architectural and planning solutions, taking into account the peculiarities of culture, traditions as well as the wishes and interests of people in a particular location. The clusters of linear cities will become a basic platform for self-organization of communities to survive under the conditions of current fierce global competition with the decreasing role and importance of state borders as some kind of socio-economic regulators.

Self-governing communities of various types, manifesting themselves in many ways – spiritual, religious, socio-economic, ethnic, organizational and managerial, communicative, political, educational, etc. – can be created in clusters of linear cities. The new type of living environment is based on the consideration and assessment of social parameters,

which implies the application of social quality components, as shown in Figure 1.

The novelty of the uSocio living environment is embedded in the idea of the universal planning element of the uCity and consists in the use of a residential building that is ecologically compatible with nature and creates conditions, which maximally support its natural state. Such dwelling is a group of individual houses interlocked into one building of considerable length ("horizontal skyscraper") and has built-in technologies that ensure the full life cycle of the system and exclude environmental pollution. A walking proximity to the main functional zones provides access to the complexes of social, educational and cultural services.

The uCity settlement (Figures 2, 3) is not only a residential but also an economic unit with the necessary engineering structure. The area of a residential cluster ranges from 1–2 km² (100–200 ha) with a length and a width of 1,000–1,500 m. The model has a high adaptive component and allows to vary the shape of the cluster from a small village on the seashore to a residential module as a part of the near-Earth Industrial Space Necklace "Orbit" [2].

Unlike the NER clusters, where the probability of meeting people close in spirit and lifestyle was determined by probabilistic coincidence, for which a group of 100,000 persons was determined, the method of constructive social stratification embedded in the arrangement of the uSocio residential environment offers a conscious choice of one's place in this or that social stratum. The planning solutions of the uCity settlements provide for this possibility.

The clusters are planned as urban-type settlements embedded in the environment. From 2,000 to 5,000 persons live comfortably in each of them. The settlement supplies itself with everything it needs: vegetable and animal food, water, electric power are produced within it on an autonomous basis. Access to the full range of services offered is guaranteed by the availability of social infrastructure and full-fledged uST transport communications of the second level. Good-neighbourly and friendly relations with spiritually close people, the opportunity to get a good education, to develop and realize one's abilities provide a high level of social quality. The integrity of project solutions makes it possible for the settlement to function self-sufficiently in a dynamic and constantly changing modern life [2].

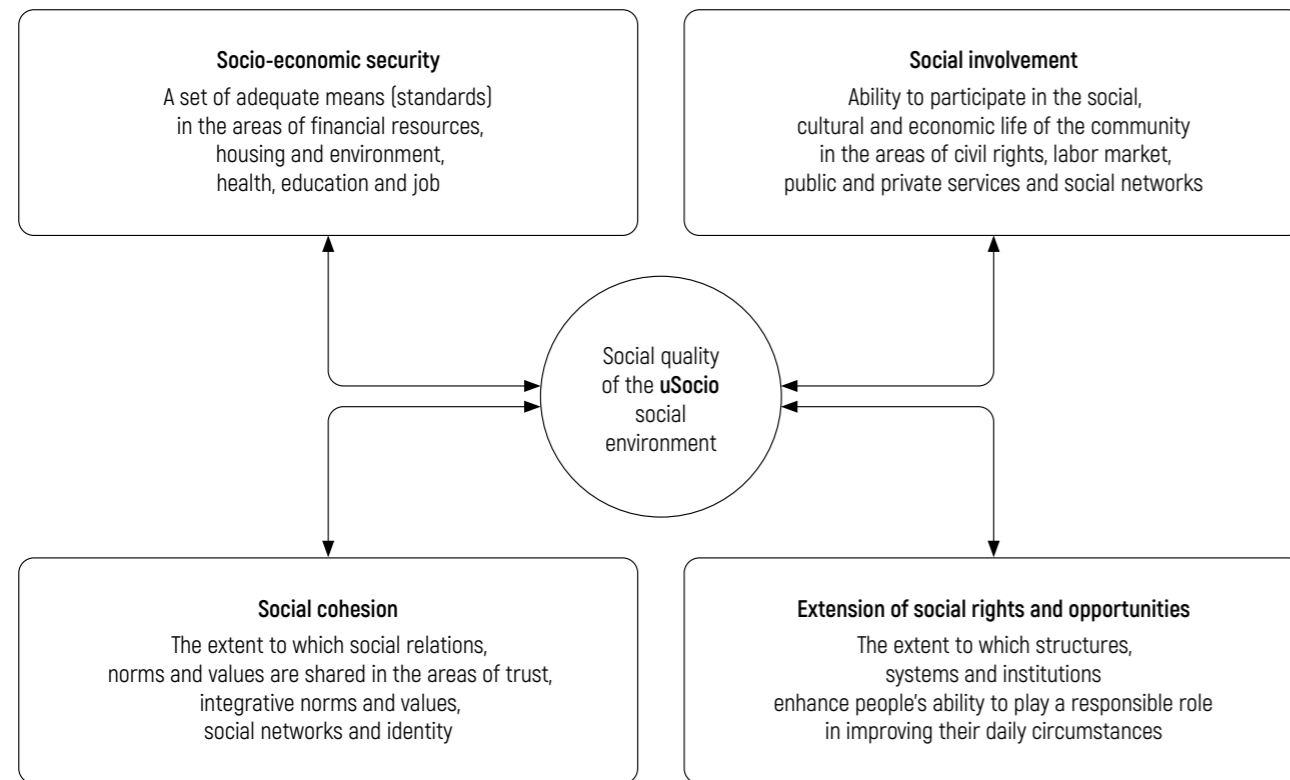

Figure 1 – Social quality components in the uSocio social environment

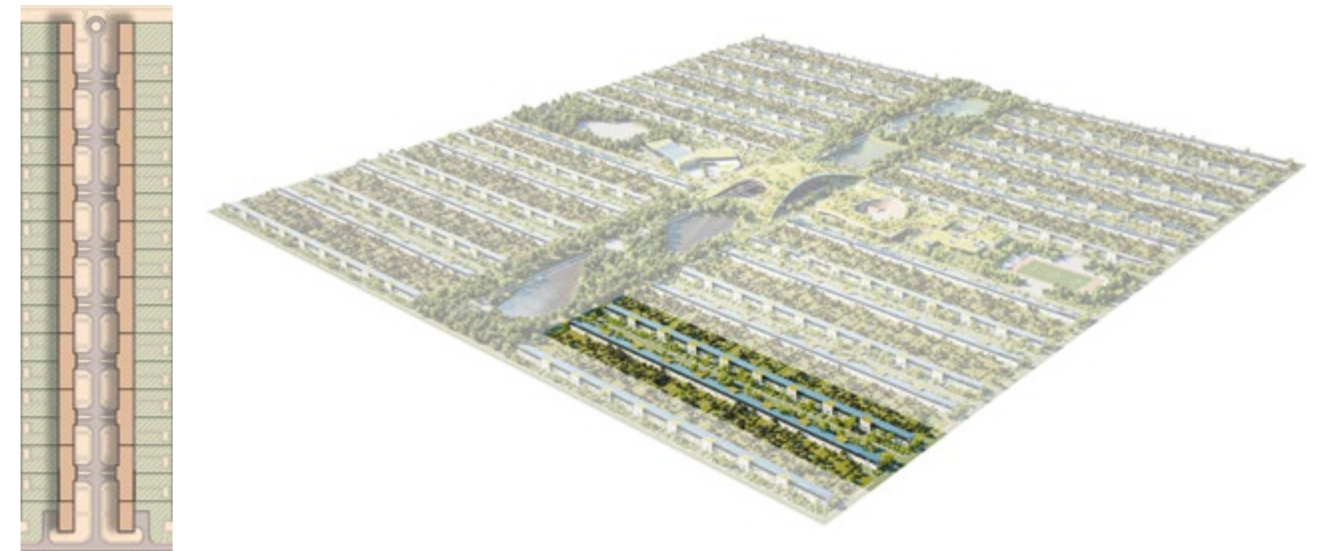

Figure 2 – Group of multifunctional residential buildings in the uCity settlement (option, visualization)



Figure 3 – Development of a residential cluster street in the uCity settlement (option, visualization)

The principle of cluster planning naturally adapts the development of a linear city to any geographical conditions and terrain specifics. The uST transportation complexes of the second level remove the limitations inherent in mountainous or waterlogged areas: the relief difference and the presence of water and other obstacles do not impede the accessibility of facilities. Engineering corridors are straightened, and the length of major communication

lines is significantly reduced. Previously hard-to-reach places and territories become attractive and convenient for people.

On the one hand, living in the described cluster (which will have its own distinctive name) gives rise to a feeling of belonging to a small homeland, a sense of a native home; on the other hand, it creates unlimited opportunities for unimpeded change of residence. The population becomes

extremely mobile within the limits of the whole planet and even beyond its borders.

Comparative diagrams of social structures of different historical epochs (Figure 4) show the transformation of social and systemic spaces: authoritative societies, where punishment dominates → disciplinary society → society of control → uSocio social environment, which allows people to develop their best qualities in an atmosphere of understanding, solidarity, involvement and self-actualization.

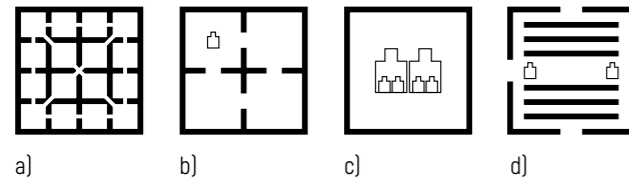

Figure 4 – Social structures of different historical epochs:

- a – authoritative society (according to G. Deleuze), which controls and owns the body of the individual;
- b – disciplinary society (according to G. Deleuze), where the individual has the freedom to move from one space of confinement to another;
- c – society of control (according to G. Deleuze), where the freedom of the individuals is compensated by a constant control over them;
- d – uSocio social environment (according to A. Unitsky), which gives the individual freedom of choice in the structure of social stratification

The previously mentioned four components of social quality (socio-economic security, social involvement, social cohesion, extension of social rights and opportunities) are ensured by the potential of free choice of one's place in the uSocio social environment of a new type – in small groups with similar interests. It is in them that the method of social stratification in its new understanding satisfies social needs of a person – sociocultural ties, common values, religious worldviews, observance of traditions, passion for art, development of ethnic and interethnic contacts, etc.

The development of the project is preceded by in-depth social research for maximum consideration of the preferences of those who will inhabit living spaces of the uCities. According to A. Unitsky, "such self-governing communities of various types, manifesting themselves in various respects – spiritual, religious, socio-economic, ethnic, organizational and managerial, communicative, political, educational, historical and ecological, etc., can be created in clusters of linear cities" [1].

Conclusion

The optimal social structure of the uSocio living environment in the uCities, including the Equatorial Linear City through which the takeoff and landing overpass of the General Planetary Vehicle will run, is arranged on the basis of the principles outlined in the theory of social quality. The historical prerequisites that emerged and developed in utopian ideas of an ideal society as attempts to achieve social harmony can be effectively used in organizing the social space of a new type of living environment, provided that they are critically conceptualized. The acceptable structure of society is determined by its tolerable impact on the Earth's biosphere and ensuring the cyclicity of biospheric processes. Viable social elements of the uCity are embodied in the space of linear settlements through a constructive social stratification of urban structures. The new type of living environment not only satisfies people's needs for housing and food but also organizes the social environment, guarantees the necessary level of social quality and brings people "something more elevated and significant: morality and ethics, co-creation and a culture of communication aimed at strengthening the family and encouraging people to show their best human qualities in all structures of society" [1].

References

1. Unitsky, A. *Civilization Capacity of the Space Home Named Planet Earth* / Anatoli Unitsky. – Minsk, 2021. – 134 p.
2. Unitsky, A. *Equatorial Linear City: Construction Features* / A. Unitsky, M. Davydik // *Non-Rocket Near Space Industrialization: Problems, Ideas, Projects: Collection of Articles of the IV International Scientific and Technical Conference, Maryina Gorka, Sep. 18, 2021* / *Astroengineering Technologies LLC, Unitsky String Technologies Inc.*; ed. A. Unitsky. – Minsk: StroyMediaProject, 2022. – P. 101–115.
3. Sushkova-Irina, Ya.I. *Dinamika sotsial'noy stratifikatsii i yeyo predstavlenost' v kartinakh mira* [Dynamics of Social Stratification and Its Representation in World Views] [Electronic resource] / Ya.I. Sushkova-Irina // *Znaniye. Ponimaniye. Umeniye*. – 2010. – No. 4. – Mode of access: <http://www.zpu-journal.ru/e-zpu/2010/4/Sushkova-Irina/>. – Date of access: 05.05.2023.
4. Foucault, M. *Discipline and Punish: The Birth of the Prison* / M. Foucault; transl. by A. Sheridan. – New York: Vintage Books, 1979. – 333 p.

5. Andryushina, A.V. *Kontseptsiya distsiplinarnogo obshchestva Mishelya Fuko* [Michel Foucault's Concept of a Disciplinary Society] / A.V. Andryushina, A.A. Pogosova // *Moloday uchonyy*. – 2020. – No. 20 [310]. – P. 239–241.
6. Bocharnikova, D. *NER: "mir, prinadlezhashchiy vsem i kazhdomu"* [NER: "World Belonging to One and All"] [Electronic resource] / D. Bocharnikova. – Mode of access: <https://yarcenter.ru/articles/culture/urban/ner-mir-prinadlezhashchiy-vsem-i-kazhdomu/>. – Date of access: 12.06.2023.
7. *Novyy element rasseleniya. Na puti k novomu gorodu* [New Element of Resettlement. On the Way to a New City] / A. Baburov [et al.]. – Moscow: Stroyizdat, 1966. – 128 p.
8. Yesionova, A. *Obshchestvo kontrolya i "Nenuzhnyye lyudi"* [Society of Control and "Unnecessary People"] [Electronic resource] / A. Yesionova, V. Yesionov. – Mode of access: <http://novoprof.net/novosti/obshchestvo-kontrolya-i-nenuzhnye-lyudi/?ysclid=1jtn26c77783635313>. – Date of access: 05.05.2023.
9. Deleuze, G. *Society of Control* [Electronic resource] / G. Deleuze. – Mode of access: <https://ai.ethicsworkshop.org/Library/LibContentAcademic/DeleuzeFoucaultDisciplineControl.pdf>. – Date of access: 18.07.2023.
10. Brodskiy, A.K. *Kratkiy kurs obshchey ekologii* [Short Course of General Ecology]: Study Guide / A.K. Brodskiy. – Saint Petersburg: Sankt-Peterburgskiy universitet, 1992. – 148 p.
11. Prigozhin, I. *Konets opredelonnosti. Vremya, kaos i novyye zakony prirody* [End of Certainty. Time, Chaos and New Laws of Nature] / I. Prigozhin. – Izhevsk: RKhD, 2000. – 208 p.
12. Prigozhin, I. *Poryadok iz khaosa. Novyy dialog cheloveka s prirodoy* [Order Out of Chaos. A New Dialogue Between Human and Nature] / I. Prigozhin, I. Stengers; transl. from English by Yu.A. Danilov; ed. and afterword by V.I. Arshinov, Yu.L. Klimontovich, Yu.V. Sachkov. – Moscow: Progress, 1986. – 432 p.
13. Yevdokimov, A.Yu. *O vozmozhnosti postroyeniya "ideal'nogo" obshchestva* [On the Possibility of Building an "Ideal" Society] / A.Yu. Yevdokimov, Ye.N. Kuznetsova // *Vestnik VGU. Seriya "Lingvistika i mezhkul'turnaya kommunikatsiya"*. – 2008. – No. 3. – P. 204–209.
14. Miller, G.T. *Living in the Environment* / G.T. Miller. – 9th ed. – Belmont: Brooks Cole, 1995. – 832 p.
15. Gumilov, L.N. *Etnogenez i biosfera Zemli* [Ethnogenesis and Earth's Biosphere] / L.N. Gumilov. – Moscow: Ayrispress, 2004. – 560 p.
16. Yefremov, Yu.K. *Landshaftnaya sfera nashey planety* [Landscape Sphere of Our Planet] / Yu.K. Yefremov // *Priroda*. – 1966. – No. 8. – P. 45–54.
17. Bobkov, V.N. *Teoriya sotsial'nogo kachestva kak innovatsionnyy instrument izucheniya obshchestva* (razmyshleniya v svyazi s mezhdunarodnym sotsiologicheskim forumom "Sotsial'noye kachestvo i sotsial'noye upravleniye") [The Theory of Social Quality as an Innovative Tool for the Study of Society (Reflections on the International Sociological Forum: "Social Quality and Social Governance")] / V.N. Bobkov, A.K. Akimov // *Uroven' zhizni naseleniya regionov Rossii*. – 2018. – No. 4 [210]. – P. 115–120.
18. Samsonov, V.V. *Sotsial'no-kachestvennaya model' v izuchenii dinamiki razvitiya sovremennykh obshchestv: vozmozhnosti i granitsy primeneniya* [Social Quality Model in the Study of Dynamics of Modern Societies Development: Opportunities and Boundaries of Application] / V.V. Samsonov, M.R. Zazulina // *Idey i idealy*. – 2020. – Vol. 12, No. 3, pt. 2. – P. 407–424.
19. Lockwood, D. *Solidarity and Schism: The Problem of Disorder in Durkheimian and Marxist Sociologies* / D. Lockwood. – Oxford: Clarendon Press, 1992. – 433 p.

Application of Legal Norms During Construction and Operation of the General Planetary Vehicle and Its Infrastructure



”

The issues of the legal norm application in outer space are considered, including those during the process of construction and operation of the General Planetary Vehicle (GPV), the GPV takeoff and landing overpass (uWay) and the Industrial Space Necklace "Orbit" (ISN "Orbit"). The current state of legal object regulation in space is analyzed, and general patterns of the legal norm operation are identified. The forecast of changes that may be needed in this area is made, considering the prospects for the industrial development of near-Earth space.

Keywords:

General Planetary Vehicle (GPV), GPV takeoff and landing overpass (uWay), Industrial Space Necklace "Orbit" (ISN "Orbit"), international law, rule of law, uSpace geocosmic program.

Introduction

The General Planetary Vehicle (GPV) is a global project, the implementation of which will involve a large number of participants [1]. The author's previous works addressed the issues of cooperation of countries as subjects of international law in the process of implementing the uSpace geocosmic program [2]. However, the state as a political institution is a fictitious (artificial) subject of law that does not have and cannot have consciousness and will, whereas always physical persons who act as its authorized representatives interact with each other. It is people, not artificial subjects (fictions), who enter into mutual relations, including those in the process of activities at cosmic infrastructure objects created within the framework of the uSpace program implementation.

Since as early as the period of primitive system people have been subjecting their behavior to certain rules: customs, moral norms, religious dogmas, etc. The most relevant regulator in modern society is the norms of law – general rules of behavior established by the state that regulate social relations [3]. The above definition indicates, among other things, such a feature of a legal norm as its application by the state. This means that it will act only on its territory, which, in turn, can be characterized as a space that includes land, internal and territorial waters, airspace above them, subsoil within the borders of the state and the so-called conditional territory (embassies in other countries, sea, river, air and space ships (stations) under the flag of the state, cables, pipelines and other objects belonging to the state and located in the open sea or space), which is completely and unconditionally covered by the state authorities [4].

The following facilities are assumed to be designed, constructed and operated as part of the uSpace program [1]:

- the GPV takeoff and landing overpass (uWay), that is a takeoff and landing, energy and communication overpass complex for geocosmic transportation, located along the equator and combined with an eco-settlement of new generation is the Equatorial Linear City (ELC);
- the GPV, that is a geocosmic reusable torus-shaped spacecraft for non-rocket near space industrialization, encircling Earth in the equatorial plane; it ensures industrial cargo and passenger flows (millions of tons and millions of passengers per year) from Earth to near-Earth equatorial orbits and back; based on the only possible (from the point of view of physics) environmentally safe and energy-efficient geocosmic transportation technology which uses only internal force of the system and electric energy;

- the Industrial Space Necklace "Orbit" (ISN "Orbit"), that is a multi-orbital transport, infrastructure and industrial-residential complex serving the Earth's humanity and covering the planet in the equator plane. It is a functional analogue of the Earth's ELC, however, located in space, as well as a range intended to protect from space threats (including meteorites) and a platform for the expansion of the Earth's civilization into deep space.

As it can be seen from the description of the abovementioned objects, they all are integral structures of universal scale, located on the territory of many states and/or in the space over which no country has jurisdiction. This circumstance gives rise to many questions in the field of legal regulation of relations between entities at such facilities, and this is the reason for the relevance of the subject of current study.

Legal Norms on the uWay

As defined above, the uWay encircles Earth in the equatorial plane and, accordingly, crosses the territories of several states and neutral waters. Application of the existing legal approaches to the subject matter would result in the following.

1. The parts of the overpass located on the territory of any of the states will be under its jurisdiction. On the one hand, this looks reasonable and simple enough, but, on the other hand, it raises a number of questions.

Thus, the uWay is an integral structure with inseparable elements serving common purpose. The large-scale facility requires proper maintenance and immediate repair in the event of a failure. Being subject to different rules and regulations, such actions will be regulated and funded differently, which can lead to unpredictable consequences for the complex as a whole. In addition, it is likely that those persons carrying out maintenance and repairs in such a situation will have to cross national borders frequently, passing through the relevant border and customs procedures.

In the course of uWay operation, passengers will be boarding (disembarking) and cargo will be loaded (unloaded), which implies a large number of people, machinery, goods and equipment in a relatively small area and their constant interaction. The lack of single regulations in different parts of the complex will inevitably lead to disputes as well as to increased time and financial expenses. For example, it is necessary to monitor constantly whether a passenger has a permit to enter the country, whether it is possible to keep the transported cargo at the point of arrival.

The application of different rules to parts of a single object seems irrational for the reasons stated above.

2. The parts of the overpass located in neutral territories may:

- belong to the states that financed or otherwise participated in their creation and form part of the territory of such states;
- have the status and legal regime of a neutral territory.

In the first case, there will be problems and issues similar to those described above. In the second case, it will be difficult to determine who should bear the costs and responsibility for the maintenance, upkeep and repair of the facility as well as for the safety of passengers and cargo while they are in the neutral territory. As can be seen, both options have significant disadvantages.

Legal Norms on the GPV Board

The GPV is a geocosmic aircraft for which the current legal regulation defines the following.

Based on Article 17 of the Convention on International Civil Aviation, aircraft have the nationality of the state in which they are registered [5].

In accordance with Article VIII of the Treaty on Principles Governing the Activities of States in the Exploration and Use of Outer Space, Including the Moon and Other Celestial Bodies (hereinafter referred to as the Outer Space Treaty), a state party whose registry contains an object launched into outer space retains jurisdiction and control over such an object and over any crew of that object while they are in the outer space, including on a celestial body [6].

Article 5 of the Agreement Among the Government of Canada, Governments of Member States of the European Space Agency, the Government of Japan, the Government of the Russian Federation and the Government of the United States of America Concerning Cooperation on the Civil International Space Station (hereinafter referred to as the ISS Treaty) states that each partner shall register as space objects the orbital elements it provides and shall retain jurisdiction and control over the elements it shall register and over the persons from the personnel of the space station, staying inside and outside of it, who are its citizens [7].

Regardless of the fact that the GPV will cross both airspace and outer space on its way, the principle remains the same: the object (part of it) is under the jurisdiction of the state in which it is registered.

Thus, it is assumed that the GPV will consist of parts registered in different countries. This division can be realized based on certain criteria:

- financing or otherwise participating in the project designing and construction of the facility;
- location of a part of the GPV on Earth;
- other division depending on the chosen basis.

The significant disadvantages of this regulatory approach stem from the fact that the GPV is an indivisible object with inseparably linked elements serving a single purpose. Formally dividing it into parts belonging to different states with different rules and regulations can lead to many problems and disputes in the operation process of the GPV. The following are among them.

1. If passenger boarding (disembarkation) and cargo loading (unloading) are subject to different rules within a single vehicle, inefficient logistics will be inevitable. Possible is an uneven distribution of payloads in parts of the GPV which has a length of more than 40,000 km and a total mass of about 40 mln tons, and this is unacceptable due to unacceptable weight distribution of the aircraft, as it may lead to a catastrophe. Given situation is likely to occur if one of the territories has less stringent rules regarding the requirements for persons staying in the country and/or goods being moved. In such a part, a queue of people waiting to board and/or load would start to appear, while in the other part there would be vacant seats. This situation is obviously not consistent with the necessary rationality in the use of geocosmic transport, for which the uniformity of payload distribution along the length is one of the key requirements.

2. If the GPV maintenance, operation and repair are performed by different entities according to their own rules, this will cause unsatisfactory condition of the geocosmic aircraft, unreasonable launch delays, accelerated failure of its elements and equipment as well as other negative consequences and even a catastrophe. All of the above may be caused by the lack of funding, various priorities of the subjects, political disagreements and other factors.

Legal Norms on the Territory of the ISN "Orbit"

The ISN "Orbit" is a multi-orbital transport, infrastructure and industrial-residential complex covering the planet in the equatorial plane and deployed in space in circular orbits.

According to the current and previously mentioned legal norms, each object (or its element) in outer space belongs to the state that has entered it into the relevant register (Article VIII of the Outer Space Treaty, Article 5 of the ISS Treaty) [6, 7]. Thus, the mentioned orbital complex will be formally divided into parts subject to diverse rules similarly to other infrastructure elements.

Unlike the uWay and GPV, the ISN "Orbit" assumes a long-term residence of people in it as well as the permanent location of residential, industrial, administrative and other facilities. On the one hand, this feature allows to consider the proposed legal regime from the position of similarity with the existing order on the planet Earth: a large number of countries with their own legislation, where citizens live, real estate objects are located and goods are moved. On the other hand, the life activities of the population at the ISN "Orbit" will be radically different.

The presence of many parts of a single complex, which are actually territories of many countries, generally implies state borders between them, as well as equipped checkpoints, which, in turn, entails the need to pass through appropriate border and customs procedures when crossing them. Such a serious limitation will have a negative impact on logistics efficiency, costs, satisfaction of the population and will greatly hinder not an easy but important task of transferring the Earth's industry into near space.

In addition, such a separation would entail maintenance, operation and possible repair problems similar to those described above for other elements of the general planetary infrastructure but on a larger scale, given the extraterrestrial location and unprecedented size of the geocosmic complex.

The issues that may be caused by applying existing approaches in the legal regulation of space objects to large-scale elements of the uSpace program are outlined in Figure 1.

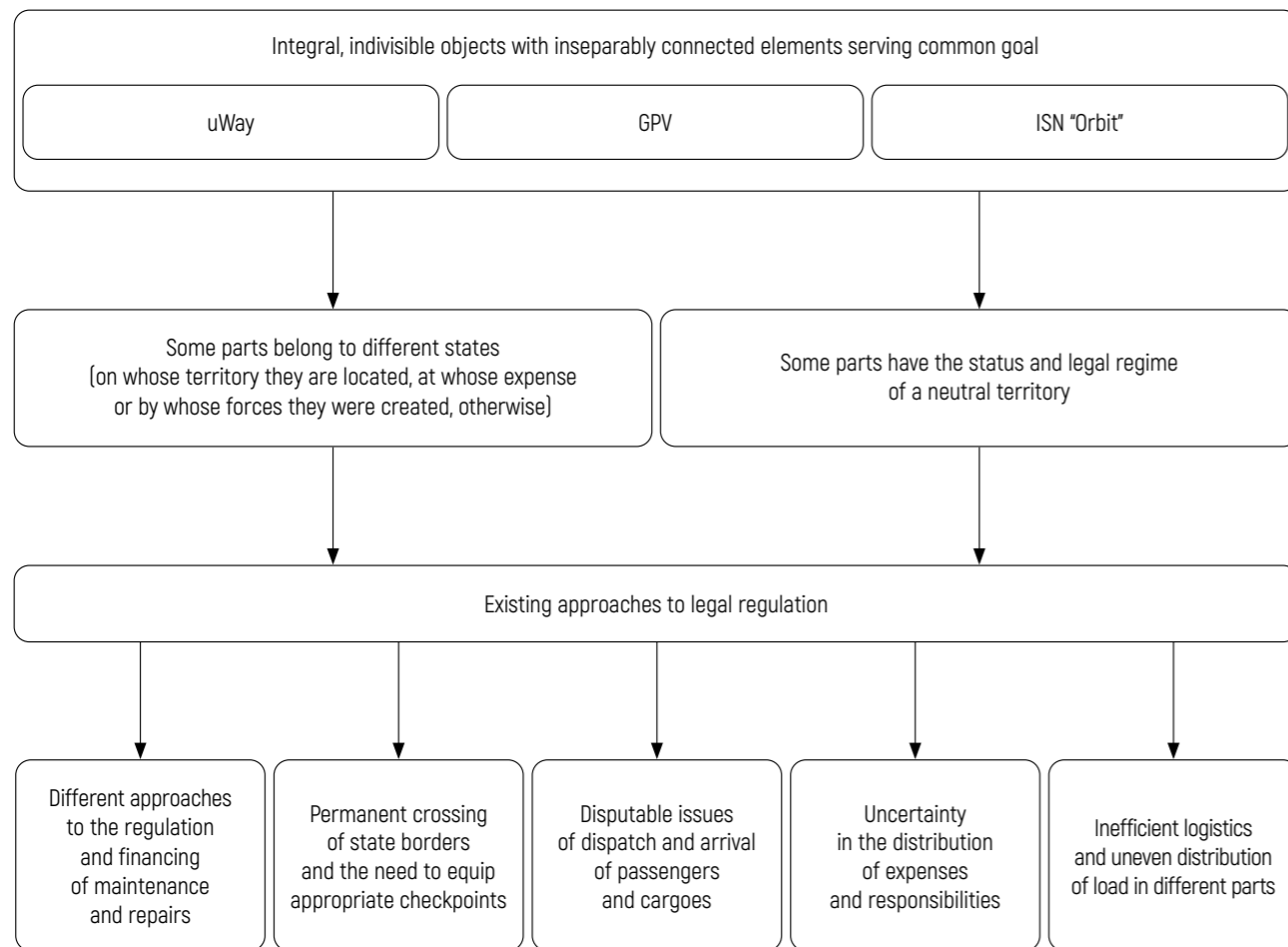

Figure 1 – Problems of application of existing legal regulation when implementing the uSpace geocosmic program

Way to Overcome the Described Legal Problems

The analysis made in this article makes it possible to draw an obvious conclusion that current approaches to legal regulation of social relations arising in the process of launching and operation of objects in outer space may be applicable during using the uWay, the GPV and the ISN "Orbit", although they have more disadvantages than advantages.

A reasonable way out of such situation is to establish uniform rules for all elements of infrastructure in any interaction. At the same time, in order for the regulation to be possible, these rules must become the norms of law. The scientific literature identifies the following features: universality (abstractness, generality, generally binding nature), authoritative nature (comes from a subject endowed with power or sanctioned by it), systematicity (it is an element of the general system of law), security by compulsory force, content in the sources of law (acts, customs, doctrine) [8].

In given context, a problematic issue is to determine the entity whose authority will allow issuing a generally binding act and ensuring its implementation in the course of the operation of the uWay, the GPV and the ISN "Orbit". A possible solution seems to be an international organization (existing or newly created for special purposes), but the use of this method initially implies excessive bureaucracy, slowness in decision-making, inability to reach an agreement between participants due to political controversies and other disadvantages inherent to multinational entities.

As an alternative, the creation of a hybrid independent entity of international law, possessing at the same time the attributes of an international organization, a state and a corporation, is proposed. It should combine autonomy, i.e., be independent in its actions and decisions from other participants of international relations, and representativeness, i.e., consist of (or take into account interests) the participants who played a significant role in the implementation of the uSpace program as well as those for whose benefit it is implemented. In this case, it needs to be recognized by the global community, as otherwise it will be difficult to build a constructive interaction.

The creation of such a subject is possible on the basis of the supreme constituent act of the common will of the participants with further strict observance of the new entity's sovereignty. The considered formation must necessarily have a structured internal system of permanently functioning bodies, realizing the entirety of power in the controlled territory and having a monopoly on legal coercion. An important element of its activities will be keeping accounting of revenues

and expenditures as well as deciding on the distribution of surplus.

The features of such a hybrid independent entity of international law are schematically depicted in Figure 2.

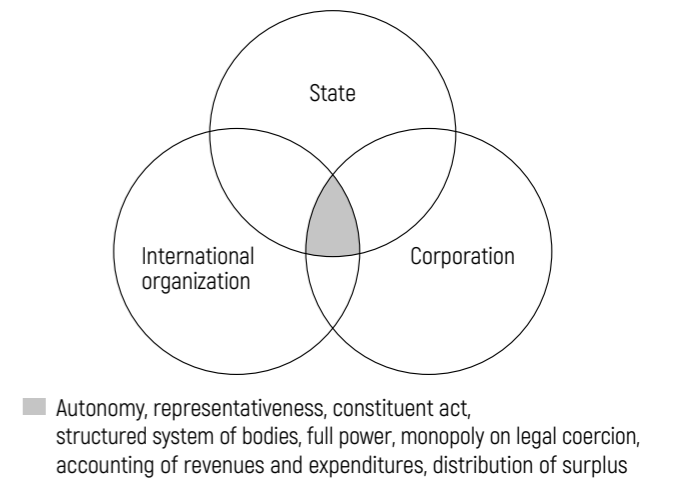

Figure 2 – Necessary attributes of a newly created entity of international law

Conclusion

The research presented in this article, concerning the possibility of applying the existing legal regulation to social relations arising in the process of operation of such planetary indivisible objects serving common goal as the uWay, the GPV and the ISN "Orbit", has revealed serious shortcomings and, probably, insoluble contradictions of such approach.

The most justified and substantiated vector of development in given direction is the establishment of uniform legal norms for all elements of the planetary infrastructure within the framework of any interaction. In this case, it is assumed to create a hybrid independent entity of international law, which:

- as a state, will be autonomous and independent, possessing full power in the controlled territory and a monopoly on legal coercion;
- as an international organization, will be representative and recognized by the international community;
- as a corporation, will be organized on the basis of a constituent act, have a structured internal system of permanently operating bodies, keep accounting of revenues and expenditures as well as make a decision on the distribution of surplus.

At the same time, the elements of the GPV infrastructure will become the controlled territory of the described new entity where it will create legal norms and ensure their execution by virtue of its power.

References

1. Unitsky, A. *String Transport Systems: On Earth and in Space* / A. Unitsky. – Silakrogs: PNB Print, 2019. – 560 p.
2. Kazakevich, A.P. *Pravovyye aspekty mezhdunarodnogo sotrudnichestva v oblasti osvoyeniya kosmosa [Legal Aspects of International Cooperation in Space Exploration]* / A.P. Kazakevich // *Bezraketnaya industrializatsiya blizhnego kosmosa: problemy, idei, proyekty: Collection of Articles of the III International Scientific and Technical Conference, Maryina Gorka, Sep. 12, 2020 / Astroengineering Technologies LLC, Unitsky String Technologies Inc.; ed. A.E. Unitsky. – Minsk: StroyMediaProyekt, 2021. – P. 102–115.*
3. Tikhomirova, L.V. *Yuridicheskaya entsiklopediya [Encyclopedia of Law]* / L.V. Tikhomirova, M.Yu. Tikhomirov. – 6th ed., supplemented and revised. – Moscow: Izdatel'stvo Tikhomirova M.Yu., 2013. – 1088 p.
4. Belyakovich, Ye.V. *O ponyatii territorii gosudarstva [On the Concept of State Territory]* / Ye.V. Belyakovich // *Sibirskiy yuridicheskij vestnik. – 2006. – No. 2. – P. 3–10.*
5. *Convention on International Civil Aviation [Electronic resource]. – Mode of access: https://www.un.org/ru/documents/decl_conv/conventions/pdf/chicago_conv.pdf. – Date of access: 05.06.2023.*
6. *Treaty on Principles Governing the Activities of States in the Exploration and Use of Outer Space, Including the Moon and Other Celestial Bodies [Electronic resource]. – Mode of access: <https://www.unoosa.org/oosa/en/our-work/spacelaw/treaties/outerspacetreaty.html>. – Date of access: 05.06.2023.*
7. *Agreement Among the Government of Canada, Governments of Member States of the European Space Agency, the Government of Japan, the Government of the Russian Federation and the Government of the United States of America Concerning Cooperation on the Civil International Space Station [Electronic resource]. – Mode of access: <https://www.state.gov/wp-content/uploads/2019/02/12927-Multilateral-Space-Space-Station-1.29.1998.pdf>. – Date of access: 05.06.2023.*
8. Alekseyev, S.S. *Obshchaya teoriya prava [General Theory of Law]: in 2 vol.* / S.S. Alekseyev. – Moscow: Yuridicheskaya literatura, 1982. – Vol. 2. – 360 p.





UDC 341.1/8+629.78

Political and Legal Justification for Implementation of uSpace Geocosmic Program Within the Framework of the BRICS International Association

A. Bakhaev
Ph.D. in Law

Chelyabinsk, Russia

”

The article considers the most relevant spheres of international cooperation, the presence and effectiveness of interstate organizations and associations. Their potential and compliance with the statutory goals of the uSpace geocosmic program have been reviewed. There is an analysis of available political and legal instruments for the realization of this program within the framework of the BRICS international association. The article contains the relevant conclusions and offers mechanisms of the project implementation which corresponds to the policy of the BRICS and the internal organizational legal procedures.

Keywords:

BRICS, international law, international organizations and associations, uSpace geocosmic program.

Introduction: Classification of International Organizations

International organizations and associations as we know them today appeared relatively recently in the last century. It is alleged that they have become full-fledged subjects of international law as well as full-fledged political players in the global arena, where previously states had been monopolists.

Currently, the largest active international organizations, associations and groups of countries are United Nations, World Trade Organization, Organization for Security and Cooperation in Europe, Collective Security Treaty Organization, Council of Europe, Shanghai Cooperation Organization, G7, G20, BRICS.

In order to realize the objectives of this study, it is necessary to provide a classification of international organizations. Its bases can be various. The systematization according to the scale of activity, purpose of activity, nature of the states' transfer of competence is widespread (Figure 1) [1].

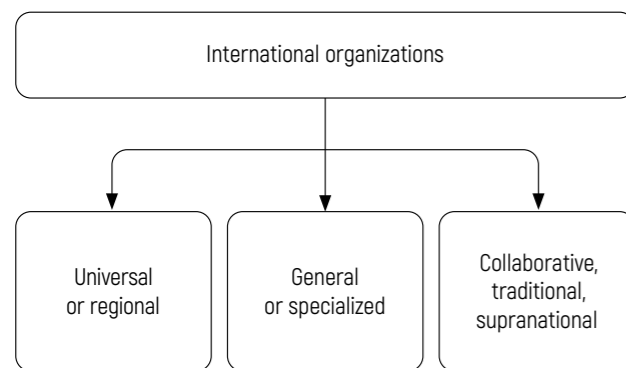

Figure 1 – Classification of international organizations

It should be emphasized that international para-organizations are entities that have features of an organization but are not such from the formal legal point of view (e.g., G7, BRICS). Often playing a significant role in international relations, they cannot be included in the classification of international institutions, as they do not get an official status: they do not have a statute, headquarters and are not institutionalized. Such associations can be either governmental or nongovernmental. In principle, para-organizations differ in the fact that they are not legally vested and do not have legal personality. They can function although with a certain composition of members but without full-fledged constituent

acts, an established organizational structure, a permanent residence and the right to make legally qualified decisions binding states. Due to the flexibility of the models of cooperation used and the informality of the decisions taken, para-organizations are widespread in the modern world, and the practical significance of their decisions, although not binding, can be very great [2].

To date, most of the above international organizations and associations have either become extremely politicized or are controlled by a small group of countries, which excludes the principle of equality, mutual benefit and achievement of the common good. Both do not correspond neither to the goals of creation and activities of such organizations nor to the goals of implementation the uSpace geocosmic program proposed by engineer A. Unitsky [3].

BRICS as a Platform for Implementation of uSpace Geocosmic Program

In today's geopolitical realities, the BRICS group of countries is the most meeting the principle of equality of parties, representing a significant amount of the planet's population and complying with the provisions included by engineer A. Unitsky in the basis of the uSpace geocosmic program.

This union is an informal interstate association of dynamically developing major states; is seen as a platform for strengthening a comprehensive interaction between those states of the world whose economies have a high potential for growth. Currently, the association includes Brazil, Russia, India, China and South Africa. The abbreviation BRICS is formed using the first letters of the names of the member states.

An important point is that BRICS cannot be called an international organization because it does not have a statute, charter or any other fundamental document defining its activities. That is why it is more appropriate to use the word "association" when referring to the BRICS. Moreover, the absence of the status of an organization in no way impedes the prosperity and development of this structure, and the time that has elapsed since its establishment has clearly demonstrated this fact [4].

The goal of the BRICS group is to collectively increase the economic growth rates of the member countries (Figure 2) and strengthen their position in the world through active cooperation with each other. It is a platform for their mutually beneficial partnership, ensuring financial and social stability [5].

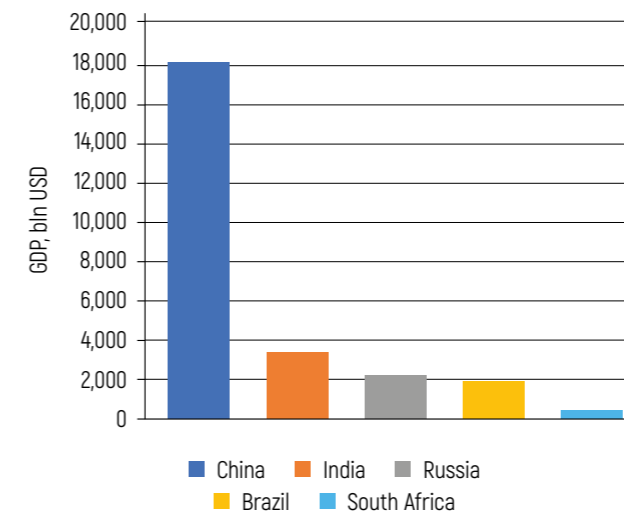

Figure 2 – GDP volume of the BRICS countries, 2022 [5]

In our opinion, and taking into account the confirming information below, it will be the most relevant and effective way to announce the initiative of the uSpace geocosmic program implementation specifically on the BRICS platform. The dynamics of submitting applications and invitations to join the association [6] suggests that in the coming years and decades the BRICS countries will shape the new architecture of the world economy (Figure 3) and determine the principles of jointly achieving an improvement in the quality of life of the population and the level of technological development.

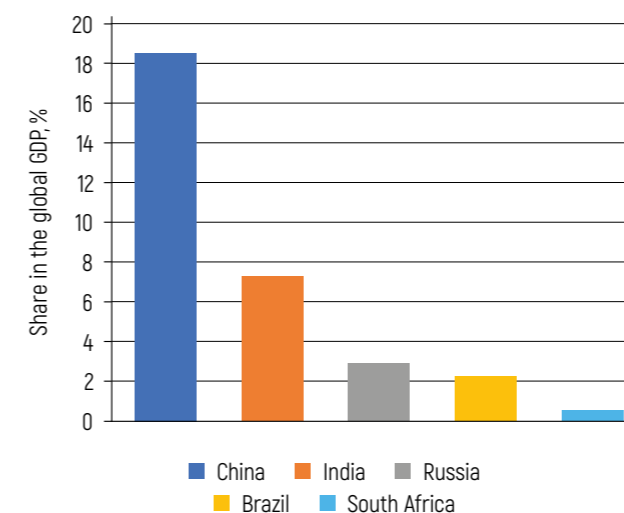

Figure 3 – Share of the BRICS countries in the global GDP, 2022 [5]

At the BRICS summit held in Johannesburg (South Africa) on August 22–24, 2023, the leaders officially declared the decision to invite new members to join the association: Argentina, Egypt, Iran, the UAE, Saudi Arabia and Ethiopia (Figures 4, 5). Moreover, it was announced that 23 states have officially submitted applications for membership, while the total number wishing to join is more than 40. According to Bloomberg [7], by 2040, the BRICS will represent half of the world's production, which is twice as much as the G7 has.

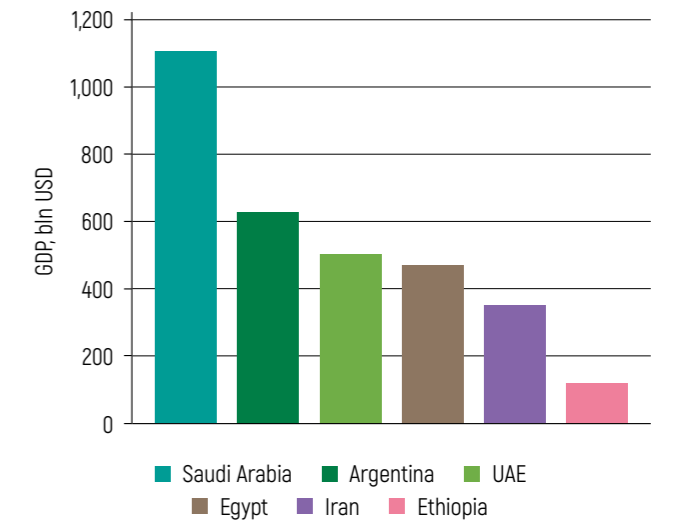

Figure 4 – GDP volume of the countries that will join the BRICS in 2024, 2022 [5]

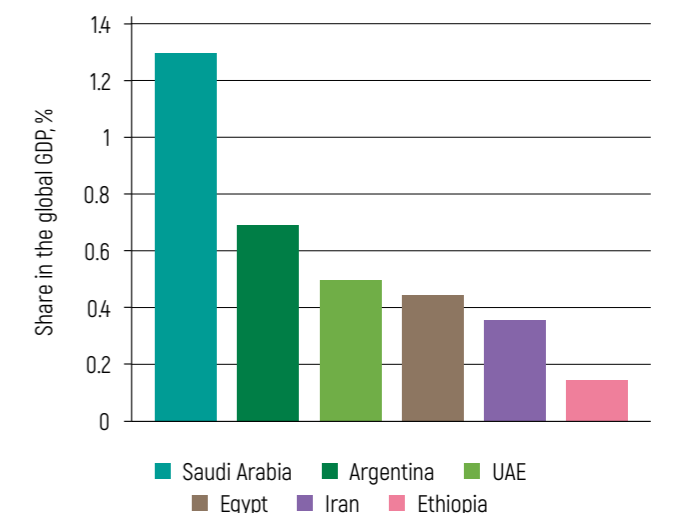

Figure 5 – Share of the countries that will join the BRICS in 2024 in the global GDP, 2022 [5]

The world population today is more than 8 bln people, while the combined number of residents of the BRICS countries is 3.2 bln (about 41.5 %). In addition, India and China rank first and second by this indicator, Brazil is seventh, Russia is ninth and South Africa is 24th.

The total number of residents of the BRICS countries exceeds the population of the G7 countries by more than four times: 3.2 bln vs. 777 mln. The total area is more than twice as large [8].

The total territory of the BRICS members is 39,746,220 km² (approximately 26.7 % of the world's landmass).

China is the world's first economy in terms of the GDP, India is the third, Russia is the fifth, Brazil is the eighth and South Africa is the 32nd.

Geography of BRICS

It is officially stated that work is currently underway to expand the BRICS group. On August 14, 2023, South African Foreign Minister Naledi Pandor announced the list of states that have expressed a desire to join the organization. Among them are Belarus, Kazakhstan, Venezuela, Bolivia, Indonesia, Vietnam, Thailand, Morocco, Bahrain, Kuwait, Saudi Arabia, the UAE, Honduras and Cuba. Algeria, Argentina, Iran, Bangladesh, Egypt and Ethiopia have applied for membership in 2022. In addition to the main participants, 67 countries, including 53 African ones, were invited to the 15th BRICS Summit [9].

The implementation of the uSpace geocosmic program involves the erection of a huge number of infrastructure facilities along the equatorial belt of Earth on the territory of more than 10 countries [3]. In addition to the fact that this project is of general planetary importance, it will also become an unprecedented driver for the development of the economies of these countries. The construction of the General Planetary Vehicle (GPV) overpass and related infrastructure will create hundreds of thousands of jobs. The required resources and materials will lead to a sharp growth in the extractive and manufacturing industries. The subsequent operation of the infrastructure, its maintenance and building of logistics chains will permanently secure the geopolitical significance and provision of financial and political resources for the equatorial belt states.

More detailed about three main territorial groups of countries on whose land the infrastructure of the uSpace geocosmic program is planned to be build is considered below.

1. South American group.

More than 60 % of the GPV overpass in South America will be in Brazil, which is already a member of the BRICS.

Moreover, Brazil is the continent's largest country both geographically and economically. The BRICS is already expanding and increasing its influence in South America and will continue to do so, as evidenced by Argentina's official invitation to join the association in 2024. At the same time, Russia and Belarus have traditionally warm and close ties with the countries of this region, which should be taken into account, because representatives of the Union State will be the initiators of the project at the first stage of its consideration and introduction into the political agenda.

2. African group.

Today, the African continent has become, without exaggeration, an arena of political struggle for influence between the Collective West and the diplomacy of Russia and Asian countries, primarily China and India. The growing economic impact of Russia, India and China allows for active participation in investment and infrastructure projects in Africa. In addition, the history of exploration and colonization of this continent predetermines the choice of the majority of African states as partners for economic development, military cooperation and comprehensive interaction with Asian countries and the Russian Federation.

South Africa is one of the most developed countries on the continent and is already a member of the BRICS. The subject of the last summit held in Johannesburg was "BRICS and Africa: Partnership for Mutually Accelerated Growth, Sustainable Development and Inclusive Multilateralism". Emphasizing the African vector is not accidental: Africa is a vast territory, a large number of residents and a serious rate of economic growth. By 2050, its population will be 25 % of the world's one, and the continent will account for 50 % of the world's increment, which will provide Africa with five times more labor force than Europe will have by then and more than China and India combined [10]. There is no doubt that the influence of the BRICS on the African continent will increase, and the number of its countries in the association will increase. Thus, Egypt and Ethiopia have already received an invitation to become the BRICS members from 2024.

3. Oceanic Group.

A significant part of the GPV overpass infrastructure facilities is planned along the territory of the so-called Oceania, island states. The main player in this region is undoubtedly Indonesia. Its economy is the largest in Southeast Asia and one of the key developing economies in the world. Indonesia is one of the countries with a growing population of over 270 mln people. This is a market with huge potential. The state's economy has passed a long way: it is now ranked

the 16th in the world but is projected to reach the fourth place by 2045 [11]. The predominance of agriculture has declined, industrial production is developing, and the GDP by purchasing power parity is 4.39 tln USD (2023). Indonesia was expected to receive an invitation to join the BRICS as early as in 2023, which was indirectly confirmed by the participation of its president in the summit, however, this did not happen. After the event, it was officially announced that the BRICS foreign ministers had addressed Indonesia with an invitation to join the alliance [12]. Indonesia's future membership in it will allow the country's representatives to be involved in the discussion of the implementation of the uSpace geocosmic program on the existing BRICS platforms.

BRICS Cooperation in Cosmic Sphere

The recent achievements of the BRICS participants in the cosmic sphere allow to conclude that there is a huge potential and interest in working together to implement the uSpace geocosmic program.

Actual issues of international cooperation in the field of space exploration and global trends in the development of space activities are already the subject of discussion and interaction between the heads of space agencies of the BRICS countries. An example of such active partnership is an agreement for cooperation in remote sensing satellite data sharing.

It should be noted that on August 23, 2023, the BRICS leaders adopted the final declaration of the 15th Summit of the association, called Johannesburg II. The issue of joint space exploration was also reflected in it. In particular, paragraph 69 states: "We congratulate our Space agencies for successfully implementing the BRICS RSSC [Remote Sensing Satellite Constellation] agreement by exchanging of BRICS Satellite Constellation data samples; holding of the 1st BRICS RSSC Application Forum in November 2022; convening of the 2nd meeting of BRICS Space Cooperation Joint Committee in July 2023 and continue to successfully implement the BRICS Constellation Pilot Projects. We encourage the BRICS Space agencies to continue enhancing the level of cooperation in remote sensing satellite data sharing and applications, so as to provide data support for the economic and social development of the BRICS countries" [13].

Realizing the importance and prospects of partnership in this area, members of the association have already established the BRICS Joint Committee on Space Cooperation. The Committee meets on an annual basis on the eve of the BRICS heads of state meeting. Within the framework

of its activities, it is proposed to promote the implementation of the uSpace geocosmic program.

Financing of uSpace Geocosmic Program Within the BRICS Framework

The scale of the uSpace geocosmic program and its transnational nature determine the corresponding amount of funding. As part of the BRICS work, the New Development Bank was set up to finance infrastructure and sustainable development projects in the BRICS states and developing countries [14].

The priority task for the New Development Bank is to support national and interstate projects, provide loans, guarantees and participation in capital. The uSpace geocosmic program will be the largest infrastructure project in history, implemented by the majority representatives of the world community. Today, all the components necessary for this are available: theoretical substantiation, technology, an international political platform, formalization tools and financial infrastructure institutions.

Earlier studies [15] have already concluded that international cooperation in the uSpace geocosmic program is possible and important and that a corresponding international treaty should be concluded [16]. At the same time, the option of working with international organizations was considered, while the BRICS is not such in the Russian legislative and international legal aspects. Nevertheless, the approaches to the implementation of the uSpace geocosmic program within the framework of the BRICS association do not differ radically from the procedural regulations generally accepted in the world practice.

Conclusion

The implementation of the uSpace geocosmic program is possible only with interstate consensus, equitable cooperation, common goal-setting and joint financing. At present, given the current geopolitical situation, the only association that meets all of the above criteria and is not managed and does not act in the interests of a narrow group of selected countries is the BRICS.

To date, the BRICS activities either already have mechanisms and institutions in place to put forward, promote and coordinate with all parties the idea of implementing the uSpace geocosmic program or there are platforms for their creation and active involvement in the process.

Practical initiation of a discussion on the implementation of the uSpace geocosmic program can be seen in the following format. It is proposed to prepare a resolution and an appeal on behalf of the forum participants to the BRICS Joint Committee on Space Cooperation by following the results of the conference "Non-Rocket Near Space Industrialization: Problems, Ideas, Projects". The document should urge the representatives of the BRICS countries to carefully study the initiative by engineer A. Unitsky and to express readiness for its comprehensive consideration. The appeal may invite the Russian Federation to become an international platform for elaboration of practical ways to implement the initiative. Based on the results of the Committee's work, a unified position of the BRICS members on the need to implement the uSpace geocosmic program should be drawn up and the issue should be prepared for discussion with the heads of state at the next BRICS Summit.

References

1. *Mezhdunarodnyye otnosheniya i mirovaya politika [International Relations and World Politics]: Textbook for Bachelor's and Master's Degree Programs / P.A. Tsygankov [et al.]*. – Moscow: Yurayt, 2019. – 290 p.
2. *Slovar' mezhdunarodnogo prava [Dictionary of International Law] / ed. S.A. Egorov. – 3rd ed., revised and expanded.* – Moscow: Statut, 2014. – 495 p.
3. *Unitsky, A. String Transport Systems: On Earth and in Space / A. Unitsky.* – Silakrogs: PNB Print, 2019. – 576 p.
4. *BRICS. Glavnoye, chto nuzhno znat' ob ob'yedinenii [BRICS. Main Things to Know About the Association] [Electronic resource]*. – Mode of access: <https://rg.ru/2023/08/22/v-iar-startoval-sammit-briks-glavnoe-chto-nuzhno-znat-ob-obedinenii.html>. – Date of access: 08.09.2023.
5. *Chto takoye BRIKS i kakuyu rol' on igrayet v mirovoy ekonomike [What the BRICS Is and the Role It Plays in the World Economy] [Electronic resource]*. – Mode of access: <https://trends.rbc.ru/trends/social/64e74e4d9a79478d9c170ea4>. – Date of access: 01.09.2023.
6. *V BRIKS ofitsial'no prigasili shest' novykh stran [Six New Countries Were Officially Invited to Join the BRICS] [Electronic resource]*. – Mode of access: <https://ria.ru/20230824/briks-1891914877.html>. – Date of access: 06.09.2023.
7. *BRICS Latest: Bloc Invites New Members, Plans Two-Tier System [Electronic resource]*. – Mode of access: [https://www.bloomberg.com/news/articles/2023-08-24/briks-](https://www.bloomberg.com/news/articles/2023-08-24/briks-summit-2023-south-africa-bloc-invites-saudi-iran-four-others-as-members)

summit-2023-south-africa-bloc-invites-saudi-iran-four-others-as-members. – Date of access: 08.09.2023.

8. *Al'yans razvivayushchikhsya: BRIKS prirastayet novymi chlenami i perspektivami trgovli v prezhnikh valyutakh [Alliance of the Developing: The BRICS Gains New Members and Prospects for Trade in Former Currencies] [Electronic resource]*. – Mode of access: <https://www.kommersant.ru/doc/6198735>. – Date of access: 08.09.2023.
9. *Reimagining Economic Growth in Africa: Turning Diversity into Opportunity [Electronic resource]*. – Mode of access: <https://www.mckinsey.com/mgi/our-research/reimagining-economic-growth-in-africa-turning-diversity-into-opportunity>. – Date of access: 04.09.2023.
10. *Indoneziya: novyy "aziatskiy tigr" [Indonesia: New "Asian Tiger"] [Electronic resource]*. – Mode of access: <https://www.skolkovo.ru/expert-opinions/indoneziya-novyy-aziatskiy-tigr>. – Date of access: 08.09.2023.
11. *Afrikanskaya povestka BRIKS: interesy aziatskikh igrokov [The BRICS African Agenda: Interests of Asian Players] [Electronic resource]*. – Mode of access: <https://www.imemo.ru/publications/policy-briefs/text/afrikanskaya-povestka-briks-interesi-aziatskikh-igrokov>. – Date of access: 08.09.2023.
12. *Indoneziya poluchila predlozheniye vstupit' v BRIKS [Indonesia Has Received an Offer to Join the BRICS] [Electronic resource]*. – Mode of access: <https://regnum.ru/news/3830005>. – Date of access: 08.09.2023.
13. *Johannesburg II Declaration. BRICS and Africa: Partnership for Mutually Accelerated Growth, Sustainable Development and Inclusive Multilateralism, Sandton, Gauteng, South Africa, 23 August 2023 [Electronic resource]*. – Mode of access: https://www.mid.ru/ru/foreign_policy/news/1901504/?lang=en. – Date of access: 08.09.2023.
14. *Agreement on the New Development Bank, July 15, 2014, Fortaleza, Brazil [Electronic resource]*. – Mode of access: https://brics2023.gov.za/wp-content/uploads/2023/07/Agreement-on-the-New-Development-Bank_2014.pdf. – Date of access: 08.09.2023.
15. *Kazakevich, A.P. Pravovyye aspekty mezhdunarodnogo sotrudnichestva v oblasti osvoyeniya kosmosa [Legal Aspects of International Cooperation in the Field of Space Exploration] / A.P. Kazakevich // Bezraketnaya industrializatsiya blizhnego kosmosa: problemy, idei, proyekty: Collection of Articles of the III International Scientific and Technical Conference, Maryina Gorka, Sep. 12, 2020 / Astroengineering Technologies LLC, Unitsky String*

Technologies Inc.; ed. A.E. Unitsky. – Minsk: StroyMedia-Proyekt, 2021. – P. 102–115.

16. *Kazakevich, A. Features of Conclusion of the International Treaty on the uSpace Geocosmic Program Implementation / A. Kazakevich // Non-Rocket Near Space Industrialization:*

Problems, Ideas, Projects: Collection of Articles of the V International Scientific and Technical Conference, Maryina Gorka, Sep. 23–24, 2022 / Astroengineering Technologies LLC, Unitsky String Technologies Inc.; ed. A. Unitsky. – Minsk: StroyMediaProject, 2023. – P. 260–267.



Cyberplan as a Tool for Rebooting Economy of the Union State of Russia and Belarus

N.I. Veduta
Strategic Planning
Scientific School,
Moscow, Russia



The main geopolitical and economic threats faced by the Union State of Russia and Belarus (USRB) are listed, and ways to overcome them are outlined. The most essential challenges were economic sanctions from the West, military operations on the western border of the USRB, information wars, westernization of the culture and values of the Russian and the Belarusian peoples, bipolarity of the world, digital dictatorship. To counter these processes as well as to strengthen the economy and policy of the USRB, it is proposed to introduce a dynamic model of interbranch-intersectoral balance, Cyberplan, into the economic management system. The first version of this tool (live planning in the USSR) proved its effectiveness during the crisis years of the Great Patriotic War and the postwar period. The model is based on a scientific cybernetic approach; the purpose of its functioning is to achieve a trajectory of constant growth in the well-being of each society's member. Currently, scientists from Moscow State University under the leadership of Professor E. Veduta, using the latest computer technology, are creating a prototype of a new generation of the model. Its implementation for planning and managing the economy of the USRB will become a tool for completing integration processes and introducing new unique technologies that will allow the USRB to take the position of a global technological leader. This paper presents the ways of achieving such leadership using the example of Unitsky String Technologies (uST).

Keywords:

Cyberplan, digital dictatorship, dynamic model of interbranch-intersectoral balance, economic management, geopolitical threats, integration, planning.

Introduction

In the light of ongoing global changes in the economy and politics as well as their impact on countries and regions, there arises the need for new tools of economic management to change the socio-economic system, which, of course, is impossible without the improvement of process technologies and the introduction of innovative mode of production. These two processes are always inseparable from each other [1, 2]. Given the slowdown of technological progress and its replacement by digitalization and digital transformation that release capital and create super profits mainly in the sphere of production and services related to information technologies, the question arises: how digital tools should be applied in such a way as to achieve a balance of sectoral development, which is so important for the economic growth in people's interests. Russian and Belarusian scientists provide practical and instrumental solutions to these challenges, i.e., their answers focus on the actions (to reboot the economy of the Union State of Russia and Belarus (USRB) on a scientific basis) and steps for executing them (to use planning and modeling with the help of the latest achievements of information technologies, including neural networks) for the transition to such a socio-economic structure that meets the USRB citizens' needs, improves the quality of life, forms the prerequisites for cultural, moral and emotional development.

Geopolitical and Economic Threats to Security of the Union State of Russia and Belarus (Decline of Capitalism and Digital Dictatorship)

Russia and Belarus are inseparable neither economically nor culturally. This has been proved by 30-year experience of the post-Soviet history of two countries, for which mutual assistance and active support have always been the basis of friendship and cooperation, and differences in language and culture have not become an obstacle or a stumbling block. Bilateral beneficial contracts between manufacturing and processing enterprises have contributed to the strengthening of economic ties. More than 2,500 enterprises operate within the USRB; 4 bln USD of Russian investments in Belarus and more than 600 mln USD of Belarusian investments in Russia have been attracted; preferential hydrocarbon supplies are being carried out; in 2022, trade turnover amounted to 434 bln USD [3].

Good allied relations became the foundation for the decisions taken in the issue of territories and borders protection from external influence in the conditions of political destabilization by the European Union (EU) and special military operation. A difficult situation has been developed on the western vector, from where dangerous challenges and threats (military actions, sanctions, information warfare) emanate, urging the USRB to deepen political and military integration [4]. The created state can be considered a consequence of another deep economic crisis, each of which ends with a war [5]. Tremendous resources are spent on countering external threats, which negatively affects the economy and internal stability of the USRB. In addition to difficulties in the economic sphere, a hybrid warfare brings about destructive projectiles in the direction of spiritual foundations and national cultures. The core of these projectiles is the imposition of antihuman, immoral values and meanings through literature, cinema, music, fine arts, fashion, lifestyle and behavioral patterns.

As a result of the abovementioned reasons, the integration processes in the USRB, designed to strengthen the economic, political and geopolitical positions of Russia and Belarus in the world, are also subject to slowdown. It should be noted that the place and role of these two countries have been overshadowed by the confrontation between two major powers – China and the United States – and the weakening of the EU as the third major participant in the world economic and political processes. It is conceivable that the USRB's objectives may be impeding the emergence of a bipolar or even unipolar world, engendering a genuinely democratic paradigm of global order wherein the significance of human life, scientific, creative and emotional development of individual are given a paramount importance. At present, both countries are experiencing a deepening of economic and political crisis, escalating information and trade wars, declining production indicators in several sectors of the economy, decreasing levels of consumption and investment activity, reducing real incomes of the population, an irresistible orientation of the cultural environment to Western values, an incomplete integration model as well as the aggravation of the military conflict on the western borders [6, 7].

In addition to geopolitical and economic threats, the USRB finds itself face to face with a new challenge – the digital transformation of the economy and government, leading to total control over the population, programming its economic activities, obtaining superprofits from mergers of the financial sphere with the IT sector and the participation of big business in making decisions of national importance.

The actual monopolization of social networks by several owners of IT corporations, the establishment of national and supranational state and non-state think tanks for ideology-designing and decision-making, the development of information-psychological technologies under the conditions of the capitalist way of production have objectively created the so-called new method of economic management – the impact on the consciousness, priorities and behavior of both large contingents of the population and organized communities. The ideology of globalism is the basis of such influence [8]. The achievements of the European civilization after the Great French Revolution, namely democracy, people power, freedom, fraternity and equality, were turned inside out and converted into a struggle for the interests of aggressive minorities – LGBT, BLM (Black Lives Matter) and other various movements. Media, social internet technologies have become an effective tool for controlled dissemination of information among the population, which is used to trusting other people's authoritative opinion.

Population of the planet is offered a new model of life organization – the "New World Order", which implies the hegemony of the United States and China. China in this model is able to dictate its own rules of the game, far from the communist ideal: about one third of the world economic growth in 2023 will fall to China [9]. In addition, this country sets the world pace in the digital economy [10], and local universities are at the top of international rankings [11].

Not least in China's development is the digital transformation, which is an accelerated computing and instantaneous document flow. Reduction of time spent on such operations releases circulating capital that can be directed to investments, including those in the real sector. In addition, such transformation is the automation of regulating the life of every member of society, which is far from democracy, justice, equality, fraternity and people's power. The observed processes emerging in the confrontation between the USA and China for global economic dominance can be called the beginning of a digital dictatorship, the antidote to which lies in an alternative way of economic management, which will be discussed below.

The components of digital dictatorship:

- a system of digital control over citizens' actions;
- a unified register of personal data;
- a unified network space;
- a system of social rating [12].

Thus, as a result of total control, the ultimate goal of the whole undertaking called "digital state governance"

is achieved – the redistribution of currently available revenues and their sources among the main players in the global market, who concentrate and enlarge their capital. However, for developed and developing countries, this has consequences in the form of a series of crises, local and international military conflicts.

The response to the crisis by authorities in both developed and developing countries is extremely primitive, characterized by the active implementation of programs aimed at artificially restraining the industrial development of the world economy, while it is the industry that is considered the basic civilizational technological platform of the whole modern humanity [8].

Under these conditions, the best solution for the USRB is to form its own pole of economic and political interaction. One of the main goals of the USRB is to create a full-fledged common economic space – with unification of taxation and pricing systems as well as with a unified currency [13]. However, at the moment it is not possible due to the absence of a common efficient tool for managing the economy – its planning and modeling. The experience of Western countries or China cannot serve as a pattern. Russia and Belarus have their own tool for economic management – a dynamic model of interbranch-intersectoral balance on the basis of cybernetic planning. It is not a spontaneous invention or a startup, it has its own history and scientific background [14].

Historical and Resource Potential of the Union State of Russia and Belarus to Create a Unique Experience of Economic Management

Not a single free and sane person would accept a digital dictatorship as a future option for himself and his children. This is proved by regular anti-globalization protests and local actions by opponents of digitalization during the COVID-19 pandemic.

There is an alternative to immersion in the proposed digital dictatorship. A state that through a solidarity decision sets the task of improving people's lives using the latest achievements of scientific and technological progress having oriented it towards serving people, rather than for total control and management of their behavior, will gain a technological leadership, economic growth and become a conduit of freedom and happiness for every member of the society.

Such a goal – the improvement of people's lives – was faced by the USSR, where to achieve it a tool for effective management of the economy with the help of cybernetics was created – the dynamic model of interbranch-intersectoral balance by N. Veduta [15].

In 1958, the laboratory of economic and mathematical research of the USSR Academy of Sciences under the leadership of economist V. Nemchinov began to develop econometric models of interbranch balance for analyzing and forecasting various scenarios of economic development based on existing trends and available parameters [16]. However, they did not take into account the feedback from economic entities. Such models are used today by the Institute of Economic Forecasting of the Russian Academy of Sciences, the World Bank, analytical centers of Western and Eastern countries for forecasting indices of economic development.

At the same time, another group of scientists, which included G. Krzhizhanovsky and S. Strumilin, engaged not in forecasting but in the development of systems for managing economic processes on the basis of live planning, which is a process of many steps to coordinate the volume and content of government orders (what and how much should be produced) with the volume of material, labor and financial resources at all links of the system of public production management (what and how much we can produce). As a result, a balance was achieved in which the fulfillment of orders was ensured by all types of resources. The orders were drawn up in such a way as to create conditions for the priority development of key sectors of the economy. Considering the producers' actual capacity, the calculating algorithm adjusted the orders accordingly. Successive calculations of the plan were continued until the "input – output" balance was achieved, thanks to which a proportional economic growth was observed. Accordingly, the balanced plan of economic development served as a basis for the distribution of production investments among the industries. As soon as the situation changed, the plan was adjusted according to the principle of rolling (online) planning. This method demonstrated its efficiency during the Great Patriotic War and became one of the key factors of the victory [1].

After G. Krzhizhanovsky and S. Strumilin, the methods of live planning were further developed by the Belarusian cybernetic scientist N. Veduta. An important part of his scientific research was the strategy of comprehensive personal development. Taking into account the necessity of forming a new person, N. Veduta used the principle of economic cybernetics to create the only digital technology that

constructs the future rather than predicting and programming it. In the scientific concept of the Belarusian researcher, the management system of public production functions as a living organism. Automation is based on the organic planning of the economy to improve the efficiency of managerial decisions.

In the late 70s – early 80s of the 20th century, the party leadership of the USSR abandoned the strategy of building communism and true democracy (power of the people), therefore it was unable to implement the cybernetic model developed by N. Veduta aimed at social progress and the construction of the future in which moral, ethical and human values played a key role [17].

The scientific and creative path of the Belarusian cybernetic scientist N. Veduta is continued by his daughter E. Veduta. Her team is engaged in the creation of a dynamic model of interbranch-intersectoral balance prototype (Cyberplan) for modeling the socio-economic development of Russia with predetermined goals to improve people's lives [18].

Cyberplanning for Transition to Postcapitalist Economy of Biospheric Civilizational Development of the Union State of Russia and Belarus

Strengthening and developing of the USRB means the creation of a single economic space where management can be performed in an innovative cybernetic way in which the settlement of economic and social problems is carried out first on the basis of calculations according to the dynamic model of interbranch-intersectoral balance and then transferred to reality in the form of decision-making on production investments.

The management of any system requires a clear understanding of the entity's needs and the quantity and quality of resources to meet them. The planning task is to determine these values, to draw up a step-by-step plan to compensate and improve the missing or low-quality resources with the help of existing or third-party resources, to calculate the consequences and results of producing the required goods in the medium and long term, to decide what investments to make and where to direct them, what the return on them will be and in what timeframe and how external and internal factors will affect the plan. It is impossible to be done manually and within the framework of purely mathematical logic.

Here, behavior algorithms of economic entities and information technologies are used. A collection of sufficient and necessary data is conducted through IT, superfast calculations are performed based on predetermined algorithms, and multiple recalculations of values are carried out to achieve a balance between costs and output.

Settlement of many economic problems (inflation, overproduction crisis, decline in consumer demand, decrease in labor productivity, unemployment, poverty, etc.) lies in the plane of calculations according to the model. However, the most important direction, in which the Cyberplan can be used, is the planning and forecasting of the emergence and introduction of production technologies and innovations. If nowadays the role of lobbying and industrial protectionism is high in domestic markets (in particular, concerning the replacement of certain fuels with alternative ones, in the field of pharmacology, etc.), then with the introduction of the Cyberplan, orders for new technological solutions with specified parameters become the result of planned calculations. This uncompromisingly leads to labor productivity growth, technological superiority, increase in social production volume, technological and economic sovereignty.

Unitsky String Technologies (uST) can be an example for unfolding the technological superiority chain [19]. Transport is an important branch of the economy, which is in a live cybernetic connection with all other productive and nonproductive industries, providing human activity as well as affecting all types of capital and the economic system as a whole.

uST solves at once a number of global problems that humanity faces:

- environmental pollution, including noise pollution;
- high cost of highway construction;
- expensive transportation of products;
- insufficient transportation accessibility and connectivity of regions, especially territories with extreme weather conditions and natural specifics [20].

The uST string rail transport overpass is resistant to low and high temperatures, snow drifts, mudslides and avalanches, river spills, earthquakes, storm winds and tsunamis [21]. With maximum haulage performance, string transport consumes a small amount of electricity and can be deployed on any ground surface – from sea bottom to desert. Through the implementation of uST, soils that can be used for agricultural, forestry, field and landscape needs will be preserved; greenhouse gas emissions will be reduced; the consumption

of petroleum products will be decreased. However, neither Russia nor Belarus is in a hurry to implement the uST transport network.

The reasons why in the USRB the latest technology remains at the stage of experimental prototypes' operation are primarily associated with difficulties caused by administrative barriers. Additionally, it is attributed to long-standing approaches to traditional transport, insufficient level of innovation receptiveness, absence of a goal to improve people's lives in the socio-economic policy of the USRB and the inability to conduct appropriate calculations to determine the size of investments in this project, the resource composition of the industry and the long-term returns from its implementation. The forecasting models used for decision-making in both countries use the system of national accounts, which is false in nature and does not reflect reality. The Cyberplan, on the contrary, is able to make such calculations. For this purpose, it only needs to have the data of the tax service and operate with the information presented in invoices, bills of lading, staff schedules, etc. Ideally, a unified reporting system should be created for the digital twin of each product and manufacturing process, which will ensure completeness and sufficiency of information for calculations according to the model.

The Cyberplan opens a broad pathway for sovereign knowledge-intensive, high-tech, green industries characterized by minimal environmental impact, efficient use of natural resources and their saving. The Cyberplan thus becomes a conduit for decision-making on the following replacements:

- traditional cities and future agglomerations by linear settlements that are ecologically clean and comfortable to live in;
- expensive and inefficient water treatment and waste incineration technologies by inexpensive, natural (biospheric) ones;
- hydrocarbon energy sources by relict solar bioenergy;
- traditional agriculture, which widely uses heavy chemicals for soil and plant treatment, by biospheric agriculture based on mass production and use of live humus that is obtained from brown coal and oil shale.

Using the Cyberplan, it is possible to calculate the project to transfer the entire terrestrial industry into space with the help of the General Planetary Vehicle (GPV) developed by A. Unitsky [22]. It means that in a precise number of years the dreams of humankind to make Earth a clean green home for people's happy life will come true.

Conclusion

Russia and Belarus appear today to be the most consistent and sincere allies. The interaction of both countries on the basis of deep mental, historical, spiritual, cultural and economic reference points is a solid foundation for the creation of a common economic space with a cybernetic planning as an economic management tool.

Both Russia and Belarus have made a slow but very successful progress in building a socio-economic base, and the events of 2022 have predetermined further acceleration of development in this direction [23].

By adhering to a single goal, provided the economic management model is changed, the USBR will experience a true reboot, with technologies at its core that will improve the lives of citizens economically, socially, environmentally, morally, culturally and in terms of values. By implementing a cybernetic planning, the USBR will make an enormous contribution to the world history – it will restrain its desire for bipolarity, prevent its anticipated end, place the individual with his needs and versatile development at the center of the progressive ideology, serve as an example for restoring peace and justice throughout the entire planet, return health to it and create all conditions for its prosperity.

References

1. Veduta, Ye.N. *Khvatit boltat' ob ekonomike! Kiberplanirovaniye – yedinstvennyy vykhod [Stop Chattering About the Economy! Cyberplanning is the Only Way Out]* [Electronic resource] / Ye.N. Veduta. – Mode of access: <https://regnum.ru/article/3234450>. – Date of access: 31.08.2023.
2. Potekhin, N.A. *O novoy obshchestvenno-ekonomicheskoy formatsii – innovatsionnom sposobe vosproizvodstva [About a New Socio-Economic Formation – An Innovative Method of Reproduction]* [Electronic resource] / N.A. Potekhin. – Mode of access: <https://cyberleninka.ru/article/n/o-novoy-obschestvenno-ekonomicheskoy-formatsii-innovatsionnom-sposobe-vosproizvodstva/viewer>. – Date of access: 31.08.2023.
3. *Mezhgosudarstvennyye otnosheniya RF i Belorussii [Interstate Relations of the Russian Federation and Belarus]* [Electronic resource]. – Mode of access: <https://ria.ru/20230723/diplomatiya-1885539796.html>. – Date of access: 01.08.2023.
4. Bakhlova, O.V. *Vozmozhnosti i ugrozy dlya integratsionnogo vzaimodeystviya Belarusi i Rossii v ramkakh Soyuznogo*

gosudarstva: strategicheskoy situatsionnyy analiz. Chast' 2 [Opportunities and Threats for Integration Cooperation Within the Framework of the Union State of Belarus and Russia: Strategic Situational Analysis. Part 2] [Electronic resource] / O.V. Bakhlova, I.V. Bakhlov. – Mode of access: <https://cyberleninka.ru/article/n/vozmozhnosti-i-ugrozy-dlya-integratsionnogo-vzaimodeystviya-belarusi-i-rossii-v-ramkakh-soyuznogo-gosudarstva-strategicheskoy>. – Date of access: 17.07.2023.

5. Shmakova, Ye. *Ekonomist Veduta: Krizis v Rossii mozhet privesti k mirovoy voyne [Economist Veduta: Crisis in Russia Could Lead to a World War]* [Electronic resource] / Ye. Shmakova. – Mode of access: <https://www.osnmedia.ru/ekonomika/ekonomist-veduta-krizis-v-rossii-mozhet-privesti-k-mirovoj-vojne/>. – Date of access: 17.07.2023.
6. *Russia Manufacturing PMI* [Electronic resource]. – Mode of access: <https://tradingeconomics.com/russia/manufacturing-pmi>. – Date of access: 11.07.2023.
7. Narivonchik, D. *Belorusskaya ekonomika: zamedleniye VPP i eksportnyye poteri [Belarusian Economy: GDP Slowdown and Export Losses]* [Electronic resource] / D. Narivonchik. – Mode of access: <https://neg.by/novosti/otkrytj/belorusskaya-ekonomika-zamedlenie-vpp-i-eksportnye-poteri/>. – Date of access: 11.07.2023.
8. Volkonskiy, V.A. *"Konets kapitalizma" i struktury vlasti: ekonomika i politika [“End of Capitalism” and Power Structures: Economics and Politics]* / V.A. Volkonskiy // *Ekonomicheskaya nauka sovremennoy Rossii*. – 2022. – No. 2 (97). – P. 22–37.
9. Yushkyavichyute, A. *Glava MVF soobshchila, chto tret' mirovogo ekonomicheskogo rosta v 2023 godu pridotsya na Kitay [IMF Chief Says One-Third of Global Economic Growth in 2023 Will be Accounted for by China]* [Electronic resource] / A. Yushkyavichyute. – Mode of access: <https://www.gazeta.ru/business/news/2023/03/26/20061295.shtml>. – Date of access: 31.08.2023.
10. Petrova, V. *Tsifrovaya dvadtsatka [The Digital 20]* [Electronic resource] / V. Petrova. – Mode of access: <https://www.kommersant.ru/doc/5774262>. – Date of access: 31.08.2023.
11. *World University Rankings 2023* [Electronic resource]. – Mode of access: <https://www.timeshighereducation.com/world-university-rankings/2023/world-ranking>. – Date of access: 31.08.2023.
12. Volkov, S.Yu. *Formirovaniye tsifrovoy diktatury kak aktual'naya obshchestvenno-politicheskaya problema [Formation of Digital Dictatorship as a Pressing Socio-political Problem]* [Electronic resource] / S.Yu. Volkov,

A.S. Kondrat'yev. – Mode of access: <https://cyberleninka.ru/article/n/formirovanie-tsifrovoy-diktatury-kak-aktual'naya-obschestvenno-politicheskaya-problema>. – Date of access: 11.07.2023.

13. Krasimova, Ye. *Razvitiye Soyuznogo gosudarstva Belarusi i Rossii v usloviyakh geopoliticheskikh transformatsiy [The Union State of Belarus and Russia in the Context of Geopolitical Transformations]* / Ye. Krasimova // *Belaruskaya dumka*. – 2021. – No. 5. – P. 57–62.
14. Veduta, Ye.N. *Ekonomicheskaya nauka i ekonomiko-matematicheskoye modelirovaniye [Economic Science and Economic and Mathematical Modeling]* [Electronic resource] / Ye.N. Veduta, T.N. Dzhakubova. – Mode of access: <https://cyberleninka.ru/article/n/ekonomicheskaya-nauka-i-ekonomiko-matematicheskoe-modelirovanie>. – Date of access: 31.08.2023.
15. Veduta, N.I. *Sotsial'no effektivnaya ekonomika [Socially Efficient Economy]* / N.I. Veduta. – Moscow: REA, 1999. – 254 p.
16. Balakin, V.S. *Iz istorii nauchnykh idey: akademik V.S. Nemchinov i problema primeneniya matematicheskikh metodov v ekonomicheskikh issledovaniyakh i planirovanii [History of Scientific Ideas: Academician V.S. Nemchinov and the Problem of the Use of Mathematical Methods in Economic Research and Planning]* [Electronic resource] / V.S. Balakin, L.P. Balakina, N.P. Paletskikh. – Mode of access: <https://cyberleninka.ru/article/n/izistorii-nauchnykh-idey-akademik-v-s-nemchinov-i-problema-priimeneniya-matematicheskikh-metodov-v-ekonomicheskikh-issledovaniyah-i>. – Date of access: 11.07.2023.
17. Veduta, Ye.N. *Tsifrovaya diktatura ili tsifrovaya demokratiya? [Digital Dictatorship or Digital Democracy?]* / Ye.N. Veduta, A.Yu. Poteryayko // *Aktual'nyye voprosy ekonomiki, upravleniya i prava: sb. nauch. tr. (yezhegodnik)*. – 2020. – No. 4. – P. 4–34.
18. Veduta, Ye.N. *Mezhotraslevoy-mezhsektorny balans: mekhanizm strategicheskogo planirovaniya ekonomiki [Interbranch-Intersectoral Balance: A Mechanism for Strategic Planning of the Economy]* / Ye.N. Veduta. – Moscow: Akademicheskyy proyekt, 2016. – 239 p.
19. Unitsky, A.E. *Soyuznoye gosudarstvo Rossii i Belarusi kak tsentr perezagruzki novogo mira na biosfernyy put' tsivilizatsionnogo razvitiya [The Union State of Russia and Belarus as a Center for Reloading the New World to the Biospheric Path of Civilizational Development]* / A.E. Unitsky // *Informatsiya i innovatsii*. – 2022. – Vol. 17, No. 4. – P. 17–33.

20. Unitsky, A.E. *Ekologicheskiye aspekty strunnogo transporta [Ecological Aspects of String Transport]* / A.E. Unitsky, M.I. Tsyrlin // *Innovatsionnyy transport*. – 2020. – No. 2. – P. 7–9.
21. *Zaklyucheniye o tselesoobraznosti ispol'zovaniya transportno-infrastrukturnykh resheniy Unitsky String Technologies v usloviyakh ustoychivogo razvitiya Arkticheskoy zony Rossiyskoy Federatsii [Conclusion on the Feasibility of Using Transport and Infrastructure Solutions of Unitsky String Technologies in the Conditions of Sustainable Development of the Arctic Zone of the Russian Federation]* [Electronic resource]. – Mode of access: https://unitsky.engineer/author/2023/zaklyuchenie_arkticheskaya_akademia_nauk_ust?lang=ru. – Date of access: 14.07.2023.
22. *Strunnnyye Transportnyye sistemy na Zemle i v kosmose [String Transport Systems on Earth and in Space]* // *Komsomol'skaya pravda v Belorussii*. – 2019. – Apr. 17. – P. 28.
23. Karpovich, O.G. *Soyuznoye gosudarstvo: itogi i perspektivy [The Union State: Results and Prospects]* [Electronic resource] / O.G. Karpovich. – Mode of access: <https://oborona.ru/product/karpovich-oleg-soyuznoe-gosudarstvo-itogi-i-perspektivy-44190.shtml>. – Date of access: 14.07.2023.



UDC 316.776.2

D. Valynets

Unitsky String Technologies Inc.,
Minsk, Belarus

Intercultural Communications Within the Framework of EcoSpace Program and Its Cosmic Vector – uSpace Program



There is an analysis of publications by Russian and other foreign experts in the field of intercultural communications. The author highlighted the most common factors that hinder interethnic communication and selected field-proven methods of effective dialogue organization as well as proposed the solutions that can be used during the implementation of the EcoSpace program. The novelty of the present study is provided by the fact that issues of building intercultural communications within this program and its cosmic vector, namely the uSpace program, have not been raised before.

Keywords:

EcoSpace program, General Planetary Vehicle (GPV), intercultural communications, intercultural competence, intercultural dialogue, intercultural education, intercultural training, uSpace geocosmic program.

Introduction

Today we are on the threshold of a widespread technological revolution, which means that humankind has a chance to enter a new stage of development [1]. At the same time, the technological progress has led to the fact that the technosphere began to occupy the place of the biosphere.

If we do not start taking some actions now to overcome the current global problem, we will come to the point of no return in two-three generations. This is pointed out by Doctor of Philosophy in Information Technologies (Transport) A. Unitsky in his research [2]. The use of space resources and removal of harmful industry outside the Earth limits is the proposed solution aimed at saving human civilization. It will allow to save the nature of our planet and to bring industrial development to a new level due to the benefits of space.

Cosmic vector of the EcoSpace program is represented by the global uSpace program, the key technology of which is A. Unitsky's idea about the General Planetary Vehicle (GPV) that can deliver cargo and passengers to orbit and back. Unlike rockets the GPV runs on electricity, which makes this type of transport safe for the environment.

A. Unitsky notes: the GPV is a global project, all of humanity should be involved in its implementation, and the countries located on the equator should be the territory for the take-off overpass location [3]. The uSpace geocosmic program provides for consolidation and civilizational patriotism on a planetary level [4].

The work on such a large-scale project requires maximum unity of the states. The unification should start with the creation of teams consisting of representatives of different cultures and nationalities. Specialists should be able to interact effectively despite all kinds of differences. Therefore, attention should be paid to the formation of intercultural communication skills among the members of such teams.

According to preliminary plans, the first stage of the uSpace program assumes the construction of the GPV overpass and should be completed by the middle of the 21st century [4]. The earlier the study of intercultural communication and ways to build it successfully begins, the easier it will be to establish work between representatives of different countries participating in the project.

Today, intercultural communications are the backbone of any international organization or business. The demand for knowledge in this area is growing, and professionals with intercultural communication skills are increasingly needed nowadays. Thus, according to experts' forecasts,

an intercultural mediator (manager) will be one of the most demanded professions in the future [5]. Modern transnational companies understand the importance of developing such competencies in personnel, therefore, employees involved in international projects undergo special intercultural training aimed at expanding knowledge about other cultures, developing certain behavioral skills, flexibility and tolerance to dissimilar behavior of partners.

The above aspects confirm the need and relevance of research in the field of intercultural communications. The author of this article has analyzed the publications of Russian and other foreign experts, highlighted the factors that hinder intercultural communication. Tried-and-true methods is proposed to build effective interaction that can be used within the framework of operations on the uSpace program.

Concept of Intercultural Communication

Intercultural communication involves various forms of interaction between individuals, groups and states belonging to different cultures. Since uSpace program participants are from different countries and nations, communication of team members should be considered intercultural.

In addition to the term "intercultural communication" there are other concepts that reflect the corresponding meaning in the specialized literature: "cross-cultural communication", "interethnic communication", "interracial communication", "transracial communication", "multicultural communication" as well as "intercultural dialogue" or "cross-cultural dialogue" [6].

The main function of any well-built communications is to ensure productive activity. On the contrary, a poorly established contact makes it difficult to achieve result. The higher is the level of mutual understanding between the recipient and the object of information transfer, the more effective the dialogue will become. The same can be attributed to interethnic social skills.

The problem of intercultural communication is that the recipients' decoding of the transmitted information depends on the specifics of the culture to which they belong. Representatives of different nations understand the received information differently, because they initially have peculiarities in communication approaches, values and traditions. Unequal perception of reality, ethnocentrism, stereotypes as well as linguistic and semantic deficiencies inevitable during interaction between representatives of different ethnic groups also complicate decoding.

The above factors can lead to intercultural conflicts. Therefore, prior elaboration of such points significantly increases the degree of mutual understanding in communication processes. This can be achieved by acquiring knowledge about other nations and developing intercultural sensitivity, which includes empathy, tolerance and flexibility.

Factors Affecting Intercultural Communications

Studying the experience of international companies, analyzing the mistakes and barriers they face when trying to set up an efficient interaction within a multinational team will help to prevent negative moments in establishing business contacts between uSpace program members. As practice shows, even a common language is not a guarantee of smooth intercultural dialogue. Such communications are usually accompanied by certain difficulties, because in addition to the level of language proficiency the processes of relations are affected by numerous factors: cultural, behavioral, psychological.

Some aspects that hinder interaction between representatives of different nations can be pointed out:

- differences in values and priorities. The greater is the distance between ethnic value systems, the more likely these aspects will evoke negative emotions, especially when intercultural encounters are ambiguous and unpredictable;
- stereotypes. Certain stereotypes about foreigners are created in the historical memory of any nation, which interfere with the worldview and understanding of other cultures, distort information about some or another sociocultural group;
- different attitude to time. Depending on this factor, researchers divide cultures into monochronic, polychronic and reactive [7].

Representatives of monochronic cultures are punctual, precise and consistent. They follow a certain logic and a preliminary plan during communications and are restrained in their emotions. They are mainly focused on short-term relationships with other people.

Representatives of polychronic cultures can be engaged in several things at the same time, easily change plans, goals and tasks. They are emotionally active and open, rarely resort to pauses and may interrupt their partners.

Representatives of reactive cultures are oriented to changing circumstances, and their behavior is a reaction to these changes. They are emotionally closed during communication

and make frequent pauses to allow their partner to speak. Interpersonal contacts are important to them;

- different attitudes towards conflicts. This factor can vary significantly depending on the culture. For example, representatives of collectivist cultures are not inclined to openly express dissatisfaction and avoid direct confrontation. Conflicts for them are a negative and unproductive phenomenon, especially if the other party behaves aggressively. A conflict is acceptable here only if the dignity of all negotiators is preserved and the interests of each partner are taken into account [8].

Representatives of individualistic cultures welcome conflicts if both sides are willing to resolve problems honestly and openly, which gives more opportunities to break the impasse here and now;

- differences in verbal and nonverbal communications. Each ethnic group has its own verbal and nonverbal means of communication. The process of understanding a foreign culture is the ability to decipher foreign codes and convert them into one's own. Nonverbal means are used to express feelings, replace words with actions and emphasize a sociocultural status. Studying these types of interaction will help to discover other peoples' values, their norms and dispositions [9];

- language barrier. Communication in a language that is not native for some participants causes misunderstanding. Feeling an imperfect command of the language, a person often creates a psychological block in advance, which negatively affects interaction with a partner;

- ethnocentrism. People tend to evaluate the behavior of others through the prism of their native culture, and other people's behavioral habits are usually regarded as strange and incomprehensible. Ethnocentrism is considered one of the most difficult psychological barriers in intercultural communications;

- different ways of expressing thoughts. Representatives of Eastern countries tend to look at the situation as a whole, for them reality is vague and full of contradictions: bad and good are in harmony. They are primarily focused on establishing interpersonal contacts in negotiations [10]. Representatives of Western cultures prefer clarity, unambiguity and consistency, and they consider the goal of communications to be the achievement of a specific and pre-planned result.

Based on the above, in order to build efficient interaction between uSpace program participants still at the stages of planning joint activities it is necessary to identify the potential problems that may arise due to national peculiarities and different worldviews. It is suggested to prevent such

moments by means of appropriate training aimed at acquiring knowledge about other cultures, overcoming ethnocentric barriers and stereotypes, developing tolerance to the behavior of partners.

In addition, at the initial stages of building a multinational team, it is necessary to prioritize those professionals who have flexible thinking and openness to intercultural interaction, willingness to change their behavior and recognize the impact of intercultural differences on the effectiveness of communication between individuals.

Intercultural Training and Intercultural Competence

In order to establish efficient intercultural communications, uSpace program participants should be an appropriate trained that will help them to become familiar with other people's ethnic values and traditions, adapt their behavior, learn to compromise and conduct a dialogue [11].

The acquisition of a set of behavioral, mental and emotional skills to understanding other nations and establishing a productive dialogue with their representatives will be the result of such training.

The intercultural competence forms a special self-awareness in individuals, which allows them to find differences and common aspects of other cultures and their own one, to critically analyze them and to integrate them into their own worldview without strong shocks. This includes the ability to prevent conflicts as well as empathy, tolerance and emotional resilience.

Intercultural Communications in Transnational Companies

Studies of intercultural communications in transnational companies show that a productive interaction between employees is facilitated by the presence of a single corporate language, personal meetings, participation in trainings and other factors [12]:

- corporate language. English acts as a common tool for communication between employees in most international companies. It is used to compile dictionaries of the organization's specialized vocabularies, templates of documents, letters and instructions. This approach simplifies the work process considerably;

- localization of communication. Face-to-face communication helps to resolve one or another issue in some countries,

but in another it is more productive to negotiate via the internet. That is why some companies set up a network of local communicators who adapt corporate messages to the local context;

- knowledge of partners' languages. Even basic language skills are often the key to flexibility and cultural understanding;

- face-to-face meetings. In addition to communication via e-mail, messengers and videoconferencing, face-to-face meetings are mandatory in most transnational companies. Sometimes this is the only way to create mutual trust, which is a prerequisite for successful cooperation;

- intercultural trainings. Transnational companies place great emphasis on developing cultural awareness, flexibility, adaptability and tolerance in their employees. For this purpose, appropriate trainings are organized and conducted either by company managers responsible for multinational communication or by representatives of agencies specializing in such trainings.

The above methods can also be applied to the staff involved in implementing the uSpace program.

It is recommended to choose a single language, e.g., English, to prepare a lexical dictionary in this language containing certain terms, such as "GPV", "EcoSpace", "uSpace", "string transport", etc.; establish a rule stipulating mandatory face-to-face meetings of all specialists at least once every six months (if team members are located in different countries). One of the most important activities is to arrange foreign language courses as well as intercultural trainings.

Trainings as a Way of Intercultural Education

There are various ways to train team members in intercultural competence. One of the most effective is to conduct special trainings, which relieve individuals of national prejudices and prepare them for unfamiliar behavior of partners [13]. Such activity involve several stages:

- training of cultural self-awareness. People study their culture, its values and peculiarities. Ethnic self-identification allows to analyze oneself more deeply within the framework of one's native culture, to understand what national traditions determine one's behavior. After passing this stage, it is easier for them to understand on what they are basing their own judgments about other countries;

- training in understanding a foreign culture. Participants receive maximum information about the nations whose

representatives they will interact: they get familiarized with customs and traditions, ethnic psychology, state structure, history, geography and philosophy;

- training in the formation of intercultural empathy. People develop their empathy, learn to put themselves in the shoes of representatives of another culture as well as to explain the behavior of partners from the point of view of their ethnicity;

- behavioral training. It is aimed to developing a certain model of behavior. A person learns practical skills that can be used to live in another culture, also ways of efficient communication with its representatives and soft transformation of conflicts [14];

- situational training. It involves reproduction of specific situations, direct interaction with representatives of another culture. At this stage, the knowledge and skills obtained at other trainings are successfully applied in practice, the elaborated communications are analyzed and work on mistakes is carried out.

It is very important for participants of the uSpace geocosmic program to pass all stages of the above trainings, which will help to establish efficient communication in the future. In addition, it is suggested to add the study of history, philosophy, values of the EcoSpace program and its cosmic vector – the uSpace program. It is recommended to arrange additional activities aimed at the development of altruism and pacifism, raising participants' awareness, understanding of the significance of the mission and involvement in the project that will lead to changes on a planetary scale.

Conclusion

Engineer A. Unitsky's EcoSpace program and its cosmic vector uSpace is a global project that will involve multiple countries and representatives of various cultures.

This article considers intercultural communications and suggests ways to develop interethnic social skills in uSpace team members. It is proposed to conduct trainings aimed to adapting behavior, overcoming stereotypes and ethnocentrism, also to fostering the skills of productive dialogue, to acquiring the ability to compromise, knowledge about other cultures, their traditions, etc. In addition, the author proposes to conduct special activity implying a deeper acquaintance with the EcoSpace program, its history, philosophy and values, which will help to form the awareness of participants' involvement in the fundamental project, a sense of common cultural and universal unity for the realization of the global goal.

References

1. Shchedrovitskiy, P. *Tekhnootimisticheskaya versiya Novoy promyshlennoy revolyutsii [Techno-Optimistic Version of the New Industrial Revolution] [Electronic resource] / P. Shchedrovitskiy. – Mode of access: <https://shchedrovitskiy.com/tehnootimisticheskaya-versiya-novoy-promyshlennoy-revoljutsii/>. – Date of access: 03.08.2023.*
2. Unitsky, A.E. *Tsivilizatsionnaya yomkost' kosmicheskogo doma po imeni Planeta Zemlya [Civilization Capacity of the Space Home Named Planet Earth] [Electronic resource] / A.E. Unitsky. – Moscow: Mir nauki, 2022. – Mode of access: <https://izd-mn.com/PDF/08MNNPM22.pdf>. – Date of access: 18.08.2023.*
3. Unitsky, A.E. *Obosnovaniye ekonomicheskoy i social'no-politicheskoy effektivnosti programmy SpaceWay dlya stran-uchastnits [Justification of Economic and Sociopolitical Efficiency of the SpaceWay Program for Participating Countries] / A.E. Unitsky, V.I. Lavrinenko // Bezzaketnaya industrializatsiya blizhnego kosmosa: problemy, idei, proyekty: Collection of Articles of the III International Scientific and Technical Conference, Maryina Gorka, Sep. 12, 2020 / Astroengineering Technologies LLC, Unitsky String Technologies Inc.; ed. A.E. Unitsky. – Minsk: StroyMediaProyekt, 2021. – P. 138–151.*
4. *Programma "EkoMir": bezraketnaya industrializatsiya blizhnego kosmosa [EcoSpace Program: Non-Rocket Near Space Industrialization] [Electronic resource]. – Mode of access: https://unitsky.engineer/assets/files/shares/2022/uSpace_program_2022.pdf. – Date of access: 18.08.2023.*
5. *Kross-kul'turnyy menedzher: kak naladit' mezhdunarodnyy dialog [Cross-Cultural Manager: How to Establish an International Dialogue] [Electronic resource]. – Mode of access: <https://trends.rbc.ru/trends/education/61b1fa299a7947495d2ab970>. – Date of access: 07.08.2023.*
6. Kazarina, L.A. *Spetsifika kross-kul'turnykh kommunikatsiy v mezhdunarodnykh proyektakh [Specifics of Cross-Cultural Communications in International Projects] / L.A. Kazarina // Azimut nauchnykh issledovaniy: ekonomika i upravleniye. – 2020. – Vol. 9, No. 1 (30). – P. 139–142.*
7. Hofstede, G. *Cultures and Organizations: Software of the Mind / G. Hofstede, G.J. Hofstede, M. Minkov. – New York [et al.]: McGraw-Hill, 2010. – 576 p.*
8. Browaeys, M.-J. *Understanding Cross-Cultural Management / M.-J. Browaeys, R. Price. – 4th ed. – Harlow [et al.]: Pearson, 2019. – 513 p.*

9. Ten, Yu.P. Napravleniya preodoleniya kross-kul'turnykh bar'yerov v upravlenskoy kommunikatsii [Directions for Overcoming Cross-Cultural Barriers in Managerial Communication] / Yu.P. Ten // Vestnik Povolzhskogo instituta upravleniya. – 2021. – Vol. 21, No. 1. – P. 63–70.
10. Vasilenko, I.A. Natsional'nyy stil' v zerkale politicheskikh peregovorov [National Style in the Mirror of Political Negotiations] [Electronic resource] / I.A. Vasilenko // Politicheskiye peregovory: Study Guide. – Mode of access: <http://politics.elib.org.ua/pages-6683.html>. – Date of access: 07.08.2023.
11. Basova, A.I. Mezhkul'turnaya kommunikatsiya. Strategii i tekhniki yeyo dostizheniya [Intercultural Communication. Strategies and Techniques to Achieve It] [Electronic resource] / A.I. Basova. – Mode of access: <https://clck.ru/35yFXU>. – Date of access: 04.07.2023.
12. Vesala-Varttala, T. Challenges and Successes in Multicultural Corporate Communication [Electronic resource] / T. Vesala-Varttala, T. Varttala. – Mode of access: <https://core.ac.uk/download/pdf/38126248.pdf>. – Date of access: 28.08.2023.
13. Sadokhin, A.P. Metod treninga v formirovanii mezhkul'turnoy kompetentnosti [Training Method in the Formation of Intercultural Competence] [Electronic resource] / A.P. Sadokhin. – Mode of access: http://ifapcom.ru/files/Monitoring/sadokhin_metod_training.pdf. – Date of access: 28.08.2023.
14. Leybman, I.Ya. Mezhkul'turnyy trening: obshchaya kharakteristika i primery uprazhneniy [Intercultural Training: General Characteristics and Examples of Exercises] [Electronic resource] / I.Ya. Leybman, M.V. Kornilova // Tekhnologii psikhologicheskogo soprovozhdeniya integratsii migrantov v obrazovatel'noy srede: Study and Methodological Guide. – Moscow: MGPPU, 2013. – Mode of access: http://pallas-crb.su/download/kabinet_psihologa/dlya_kolleg/tehnologii.pdf. – Date of access: 28.08.2023.



Resolution of the VI International Scientific and Technical Conference “Non-Rocket Near Space Industrialization: Problems, Ideas, Projects”

On October 7–8, 2023, the VI International Scientific and Technical Conference “Non-Rocket Near Space Industrialization: Problems, Ideas, Projects” was held in Maryina Gorka (Republic of Belarus).

The event program included a plenary and stand sessions, section work, discussions as well as the exhibition and demonstration of innovative space, infrastructure, transport and logistics, energy and agrobiotechnology. Herewith, 34 reports were presented to the audience.

The conference was held as part of the UN World Space Week and became a landmark international event in the field of space industrialization. Its purpose is to summarize the results of research and practice work carried out in scientific organizations, design bureaus and engineering companies as well as by individual scientists and enthusiasts in the following areas:

- the solution of contemporary global biosphere issues by geocosmic means;
- the prospects for the technological exploration of near space within the framework of the uSpace program under the motto “Earth – for Life. Space – for Industry”;

- the organization of safe large-scale cargo and passenger flows along the Earth – Near Space – Earth route to develop the space industry in the interests of Earth’s civilization;
- the design features, the search for biological and environmental solutions for the sustainable functioning of the Earth’s biosphere, the preservation of biodiversity on our planet and the development of hard-to-reach territories with unfavorable conditions for human life;
- the specifics of the social organization of linear cities (uCities);
- the features of international and intercultural relations and the creation of international associations for the implementation of the uSpace geocosmic program;
- the problematic aspects of social media usage in the uSpace program and the search for effective solutions;
- the development of technology for the manufacture of plant products within the framework of the EcoCosmo-House project and at orbital stations intended for long-term human habitation in space;



RESOLUTION

of the VI International Scientific and Technical Conference
“Non-Rocket Near Space Industrialization: Problems, Ideas, Projects”

- research and development work on the creation of a self-supporting geocosmic aircraft – the General Planetary Vehicle, its land and orbital infrastructure: transport, energy and information.

Based on the results of the VI International Scientific and Technical Conference "Non-Rocket Near Space Industrialization: Problems, Ideas, Projects", the Organizing Committee and participants made a number of decisions.

1. Give a high assessment to the scientific and technical level of the presented reports.
2. Mark the universal human importance of the program devoted to the large-scale near space exploration and the reboot of Earth's industry onto the biospheric vector of civilizational development.
3. Emphasize the importance of the global geocosmic project on creating the General Planetary Vehicle as the only one possible option from an engineering point of view, therefore, a key transport and logistics solution for the industrial development of near space.
4. Highlight the paramount importance and obvious relevance of developing cooperation between countries,

international organizations, leading global companies, research institutions and universities in order to implement the uSpace geocosmic program, considering the scale of the work presented at the conference.

5. Prepare a resolution and appeal on behalf of the conference participants to the BRICS Joint Committee on Space Cooperation in order to study the possibility of practical implementation of the uSpace geocosmic program for the industrialization of near space by the BRICS member countries in the logic of "Earth – for Life. Space – for Industry". Invite the Russian and Belarusian side to become an international platform for developing a roadmap for promoting this program with the aim of solving almost all global civilizational problems of our time comprehensively: infrastructural, resource, energy, food, environmental, socio-economic, demographic, economic-political, etc.
6. Regularly participate in specialized international events, conduct presentations and submit scientific reports on developments and achievements within the framework of the uSpace program in order to attract a wide range of researchers involved in the problems of industrial exploration of near space.

7. Study the applicability and effectiveness of using the N. Veduta's algorithm of the dynamic model of interbranch-intersectoral balance as one of the tools for rebooting the economy of the Union State of Russia and Belarus as well as the world economy.
8. Publish a collection of conference materials. Ensure its representation in national and largest specialized libraries in the world as well as presence and promotion in electronic format on relevant scientific portals and platforms. The participants whose work will be published must submit them in the form of scientific articles in accordance with the requirements.
9. Hold the next conference in 2024 under the name of The 7th Global Conference on Near Space Industrialization (GCNSI 2024), in order to reach a new level of public awareness and support, to use the most effective ways of promoting and implementing the uSpace program. For this purpose, select the most suitable international platform, invite strategic partners interested in rapid industrialization of near space to the dialogue and also ensure the participation of key international organizations, major research centers, leaders of nations and heads of state.

The Organizing Committee of the conference expresses gratitude to all participants, speakers, guests as well as funding structures and individuals who made the event possible: the Chairman of the Board of Directors of Unitsky Group of Companies, the main investor of the uSpace geocosmic program and this scientific forum – Mr. Anatoli Unitsky; the organizers of the conference – Astroengineering Technologies LLC, Unitsky String Technologies Inc.; Unitsky's Farm Enterprise that provided the platform and extensive assistance in holding the conference; Universal Mobility LLC, UVR LLC and SW PLANT LLC for assistance in creation of the exposition; other companies that took part in the preparation and organization of the event.

Conference Organizing Committee
Oct/8/2023

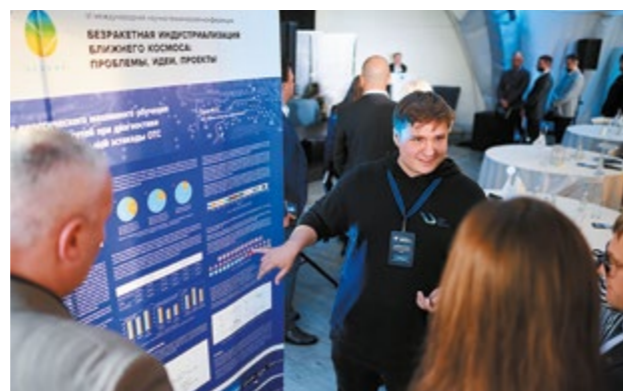

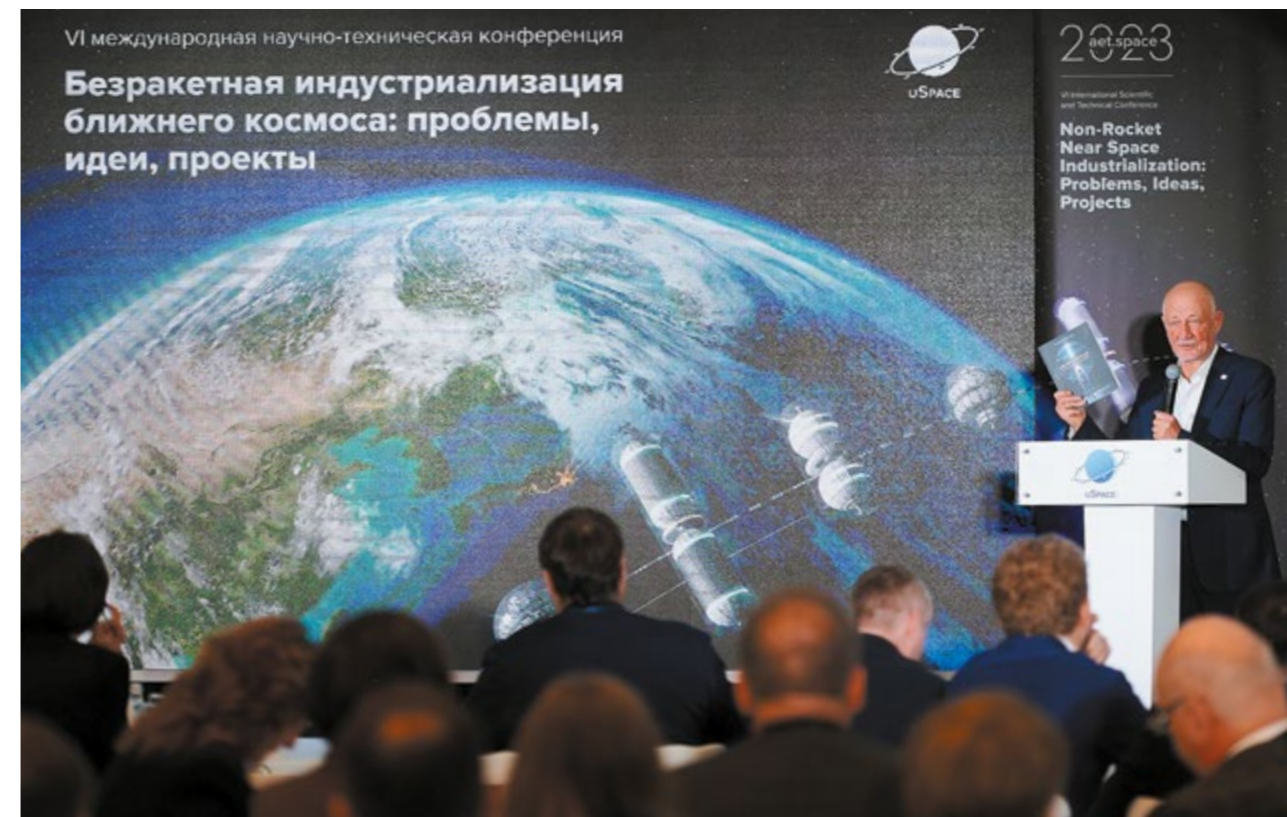

Glossary: Terms and Definitions

Abbreviation **uST (UST)** stands for the central brand of Unitky Group of Companies (UGC); it combines the names of Unitky String Technologies (uST), the parent engineering company Unitky String Technologies Inc. (UST or UST Inc.), uST transport and infrastructure complexes / Unitky String Transport as the physical embodiment of uST transport and infrastructure solutions.

Active protection system (APS) is a generator of electrostatic field where negatively charged debris of space garbage create resonant vibrations in it.

Artificial atmosphere is a specially selected mixture of gases, which ensures regular breathing and gas exchange in living organisms, including humans, who are in an enclosed ecosystem; has the same quality as the Earth's atmosphere. The gas component of the EcoCosmoHouse (ECH) space is an artificial atmosphere.

Biofuels are various types of combustible products derived from plant raw materials. Their main advantages are renewability and accumulation of solar energy coming to Earth.

Biological balance is the preservation of dynamic stability of natural complexes (biogeocenoses) over a long period of time, i.e., relative balance of stability of species composition, number and productivity of living organisms.

Biological diversity is the natural diversity of life in every manifestation as well as an indicator of the complexity of the biological system, the diversity of its living components. Biodiversity is considered at the hierarchical levels of life organization with the following main ones: molecular and genetic, organism and species, biogeocenotic and biospheric.

Civilization technogenic fork is a stage of development of the Earth's technosphere, which, when achieved, makes the technogenic human civilization face with a historically important choice of two mutually exclusive scenarios of action:

1) Earth's civilization continues to develop conventional technogenic vector, limited only by the planet's size and resources. At the same time, resource consumption does not change

dramatically because the world economy relies on obsolete and resource-intensive technologies (primarily, century-old transport and logistics technologies). As a consequence, the point of no return from degradation, extinction and death of human civilization will come in about two generations (in the third quarter of the 21st century);

2) the beginning of near space industrialization, gaining access to its unlimited resources, infinite space, matter and energy as well as new technological resources: weightlessness, deep vacuum, technological purity (without dust and microorganisms) and cosmic radiation. Mandatory requirement: inefficient transport and infrastructure technologies, power industry, habitat (cities), infrastructure and agriculture used on the planet, which pose the greatest threat to the Earth's biosphere, must be replaced by better communications and eco-oriented technologies.

EcoCosmoHouse on planet Earth (ECH-Earth) is a structure on Earth designed for autonomous and unrestricted long-term residence of a human settlement with calculated density. The inner enclosed space of the ECH-Earth provides conditions for the development of ecosystems, has a necessary set of the planet's biosphere properties in this regard and additional technological processes that are modeled to ensure human needs for existence (parameters of the atmosphere and habitat, food resources, etc.). The ECH-Earth is an Earth biospheric model of the ECH in terms of creation and arrangement of internal space and all relevant components (biosphere, technologies, process interconnections, etc.) with an enclosed cycle of matter (living and mineral), energy and information.

EcoCosmoHouse technological platform (ECH) is the construction of buildings in space with an internal inhabited space, isolated from the external aggressive space environment. There is an enclosed ecosystem of the Earth's type in the ECH, including artificially produced gravity, living fertile soil, flora and fauna (comprising microflora and microfauna), atmosphere with adjustable parameters (temperature, humidity, etc.) for unlimited long-term, autonomous, eco-comfortable living and activity of both individuals and groups of them and many thousands of settlements in equatorial orbits of the planet as well as in open near space and deep space.

EcoHouse technological platform is an eco-oriented construction of residential and industrial buildings and structures on Earth with adjacent space open to the external natural (biospheric) environment, filled with natural and cultural (organic farming) ecosystems, in which atmospheric, soil and water parameters are regulated by the Earth's nature. The soil from under the buildings during their construction is transferred to the roofs and floors to be then enriched with living humus. Greening is based on the principle that all construction on the planet is meant to increase the area of fertile soil and its fertility.

EcoSpace is the program to provide for the development of eco-oriented biospheric technologies in order to transform the main sectors of the Earth's industry, infrastructure, power industry, transport and agriculture. It assumes bringing the hazardous part of the Earth's industry out into near space to secure the balance in a perfect world represented by BioSpace, TechnoSpace and HomoSpace triunity, which together form a complex of optimal conditions for sustainable growth and further development of the Earth's technogenic civilization in cosmic direction.

BioSpace is a restored and balanced planetary biospheric ecosystem open to space, which no longer experiences the devastating human-made effects of the Earth's technosphere and continues to evolve by the laws of evolutionarily established terrestrial nature. It comprises:

- natural and cultural (organic farming) ecosystems on the planet land, including aquatic ones (lakes, rivers, etc.);
- oceanic, marine and atmospheric ecosystems with the possibility of eco-friendly external control of weather, climate and other systems of the planet through natural methods;
- flora and fauna of terrestrial and aquatic ecosystems (including microflora and microfauna) with their biodiversity preserved and currently available;
- Earth's humanity with each individual being healthy and happy.

TechnoSpace comprises newly created industrial components:

1) Earth's industry which is based on novel eco-oriented technologies and consisting only of the technological industries necessary for humans within the Earth's biosphere;

2) space industry, including energy-consuming, resource-intensive, hazardous and other industries that are moved outside the Earth's biosphere, which acquire an absolute competitive price and quality advantage as part of the space technological environment;

3) the GPV geocosmic transport complex, providing environmentally friendly transport and logistics link between the Earth's and space components of the industrial TechnoSpace with cargo, energy, information and passenger flows of industrial scale;

4) artificial intelligence to manage the above components 1-3 under the multilevel control of HomoSpace.

HomoSpace is an advanced world sociopolitical system based on the consolidation of the international community of biological humans (but not digitized biorobots-convergents) around a single governing center accumulating the territorial, financial, economic, scientific, human, military and political potential of all participating countries. This will open the gate to inexhaustible and accessible resources of space and through space-oriented economy of the technogenic civilization on Earth will create new sociopolitical and economic conditions for the most complete implementation of sustainable development of biological humanity, including social justice, equality, freedoms, harmonious development as well as the right of every inhabitant of the planet for a worthy long and happy life. HomoSpace is developed and governed by people using artificial intelligence as an assistant and advisor (but not a leader). The main value of HomoSpace is the humane attitude of Human and his spirituality as a sociobiological quintessence created by the Universe (God) as a result of billions of years of life evolution in the space home named Planet Earth.

Ecosystem is a biological system (biogeocenosis) consisting of a community of living organisms (biocenosis), their habitat (biotope) as well as a system of connections that exchange substance and energy between them.

EcoTechnoPark is a demonstration and certification center for uST transport and infrastructure solutions, built in the Republic of Belarus (Maryina Gorka).

Equatorial Linear City (ELC) is the Earth's component of geocosmic transport and communication complex which locates the GPV takeoff and landing overpass (uWay)

with the whole infrastructure required for the GPV to fly and for servicing global geocosmic cargo and passenger flows. This city represents a harmonious blend of cluster settlements with the natural environment of land and ocean areas of the planet. The settlements are interconnected by uST tracks and stretch along the equator.

Food solar bioenergy (FSBE) is power industry based on the integrated consumption and processing of biomass of greenery that has absorbed the energy of the Sun to produce biofuels, animal feed and food for humans.

General Planetary Vehicle (GPV) is a geocosmic self-supporting reusable torus-shaped spacecraft for non-rocket near space industrialization, encircling Earth in the equatorial plane; it ensures industrial cargo and passenger flows (millions of tons of cargo and millions of passengers per year) from Earth to near-Earth equatorial orbits and back; it is based on the only possible (from the point of view of physics) environmentally safe and energy-efficient geocosmic transportation technology which uses only internal force of the system (spacecraft) and electric energy.

GPV takeoff and landing overpass (uWay) is a takeoff and landing, energy and communication overpass complex for geocosmic transportation, located along the equator and combined with a linear eco-settlement of new generation.

Industrial Space Necklace "Orbit" (ISN "Orbit") is a multi-orbital transport, infrastructure and industrial-residential complex serving the Earth's humanity and covering the planet in the equator plane. It is a functional analogue of the Earth's ELC, however, located in space, as well as a range intended to protect from space threats (including meteorites) and a platform for the expansion of the Earth's civilization into deep space.

Linear city (uCity) is a cluster-type pedestrian urban settlement with its ground surface intended for people, animals and greenery; the development of residential, administrative, industrial and multifunctional clusters is implemented through the eco-oriented EcoHouse technologies; electricity and heat are obtained by the uEnergy technology; food supply is linked to the uGreen technology of organic farming; transport, energy and information communications are arranged above ground on the second level (elevated version) according to the uST technology.

Linear cities are characterized by the absence of devastating human-made effects on the biosphere, high efficiency of urban economy and its autonomy as well as decent quality of life and working conditions for each resident.

Relict solar bioenergy (RSBE) is power industry based on the use of fossil brown coal and oil shale to produce clean energy and form living humus, which is necessary to restore the fertility of various types of soils.

Space-based solar power plant (SBSPP) is an orbital solar power plant using solar energy; it provides energy independence and biospheric environmental safety of the ISN "Orbit".

Space industrialization vector is a global re-equipment of the Earth's technosphere to eliminate its devastating human-made effects on the Earth's biosphere by transferring hazardous, energy- and resource-intensive industries into near space on low-Earth orbits. The space industrialization vector is also about using eco-oriented technologies to modernize that part of industry still on Earth and functioning in the biosphere.

Sustainable development is "the development that meets the needs of the present without compromising the ability of future generations to meet their own needs". This concept was formulated by the UN World Commission on Environment and Development and is the basis of the UN goals and principles.

Sustainable Biosphere Cluster (SBC) is a competence center for desert greening. The SBC will be the basis for the implementation of the uGreen technology platform under the conditions of a hot tropical climate – an environment with negative impact factors (i.e., high temperature) affecting plant cultivation.

Sustainable-BioTech is an ecological system combining a set of innovative engineering, agro-, bio- and soil-forming technologies. Its main components are relict and organic raw materials as well as soil untouched by plowing and soil microorganisms, taken in a special way from the world Bank of fertile soils, located on the territory of Unitsky's Farm Enterprise. Raw materials are finally processed into a living fertile humus with the help of associations of soil microorganisms and a unique species of *Lumbricus* uTerris worms, specially bred in Unitsky's Farm Enterprise.

uBioSystem is an enclosed ecosystem with controlled technological processes (lighting, temperature schedule, air-blasting, water flow rate, etc.) for autonomous and long-term existence of a community of living organisms.

uEnergy technological platform is designed to generate green electric and thermal energy using:

- specially equipped thermal power plants for eco-friendly combustion of brown coal, shale, peat and other raw materials of organic origin in order to produce living fertile humus from their combustion waste;
- renewable energy sources, namely the solar energy on Earth and in space as well as the energy of wind and sea currents;
- "hydrogen – oxygen" pair as a fuel accumulator for the optimization of the planet power industry and space transportation.

uGreen technological platform is organic farming in a new logic of recreation and intensification of natural biospheric processes by direct borrowing and using natural soil ecosystems with their microflora, microfauna and biogenesis as well as in the logic of a complete rejection of any synthetic chemicals (fertilizers, plant protection agents, etc.), technologies of genetic modification and other elements of traditional intensive farming.

uMach is the concept of a hypervelocity uST transport and infrastructure complex. It is designed to travel at speeds over 1,000 km/h inside a forevacuum tunnel (with artificially reduced atmospheric pressure) to provide high-speed transportation for long (from 200 km) distances.

uNet transport and infrastructure network is an international transport, energy and information communication network created on the basis of uST transport and infrastructure solutions along uCities.

uSky Test and Certification Center is a research and production cluster of uST transport and infrastructure solutions, built in the United Arab Emirates (Sharjah).

uSocio is a new type of optimal social environment for small groups of individuals (2,000–5,000 people) which is based on stratification. In uSocio, due to the possibility of free choice of accommodation, the following social needs will be fulfilled: sociocultural ties, common values, religious outlooks, respect of traditions, passion for the arts, development of ethnic and interethnic contacts, etc.

uSpace geocosmic program is a program of non-rocket near space exploration by means of the GPV, which will preserve the Earth's biosphere by taking the industry (technosphere) outside of planet Earth (beyond the biosphere).

uST technological platform is the construction (along uCities) of a new kind of transport, infrastructure, energy and communication networks uNet, created on the basis of prestressed (string) Unitsky's structures. It is designed to provide all necessary communication links between objects (and continents) on Earth; between objects in near space moving on circular equatorial orbits; between objects on Earth and those deployed in near space.

uTerra is a biohumus (crumbly and liquid – fertility elixir) produced using brown coal, ash, organic raw materials, inoculum, aerobic and anaerobic microorganisms to increase fertility and improve the quality of any soils, including desert sands.

Reviews for the Collection of Articles of the VI International Scientific and Technical Conference “Non-Rocket Near Space Industrialization: Problems, Ideas, Projects”

Review by Yuri Pleskachevsky,

**Corresponding Member
of the National Academy
of Sciences of Belarus,
Doctor of Engineering Sciences,
Professor, Honored Scientist
of the Republic of Belarus**



Earth – for Life. Space – for Industry.
A. Unitsky

The materials included in the reviewed collection demonstrate a qualitatively new level of depth and breadth of elaboration of almost the entire range of problems, ideas and projects presented at the previous five conferences. And problems undiscussed before were also raised.

A number of works are devoted to the research, calculation, modeling and designing the General Planetary Vehicle (GPV) and takeoff and landing complex as a whole, which must meet a number of complicated, sometimes mutually exclusive requirements. These requirements are especially high for the oceanic sections of the equatorial takeoff and landing complex and the need to ensure the maximum possible “evenness” of its runway. The calculations carried out and the original designs proposed confirm the possibility of solving these problems successfully, considering the safety of navigation. It should be noted, however, that the safety issues of air communications, which inevitably arise when the GPV ring enters orbit and returns to Earth, have not yet been discussed. A relevant separate global air traffic control service should be created.

The “heart” of GPV is a linear electric motor, capable of accelerating the rotor to speeds of 11–15 km/s, required for launching from Earth and the GPV’s entrance into near-Earth orbit. In this case, being already in space, the movement of the rotor at the indicated speeds should not be interrupted. The variants of design solutions for a linear electric motor

both on permanent magnets and electromagnets are proposed. It is rightly marked that the system based on the Meissner effect, i.e., quantum levitation on superconductors, will have the lowest energy consumption.

The neodymium magnets, proposed by the linear electric motor’s developers, are made from an alloy, the main elements of which is neodymium, iron and boron. Such magnets are virtually eternal, losing no more than 1 % of their magnetic force in a hundred years. They are almost impossible to demagnetize or remagnetize. But at temperatures of 900 °C or more, the so-called Curie point is exceeded and neodymium magnets lose their magnetic properties. At the stage when the GPV is entering the orbit and returning from it, that is not excluded that there is a violation of the tightness of the vacuum channel where the rotor levitates, for example, due to a meteorite strike. In dense layers of the atmosphere, this will lead to an instantaneous, local in the best case, increase in the temperature of the rotor elements, loss of their magnetic properties and the fall of a rotor’s part onto the stator. And this is the most “soft scenario”. Therefore, a mixed levitation system using electro- and permanent magnets, including superconductors, seems more reliable. The GPV’s developers and their leader, the outstanding engineer A. Unitsky, see such a danger and therefore are purposefully developing anti-meteorite protection for the GPV’s body. Foam materials based on light metals described in the collection are promising in this regard. According to the reviewer, the effectiveness of the protective properties of foam metals can be significantly increased

REVIEWS

for the Collection of Articles of the VI International Scientific and Technical Conference
“Non-Rocket Near Space Industrialization: Problems, Ideas, Projects”

by creating a closed-porous foam structure with biconvex cell walls, which provides negative Poisson's ratio values. The deformation and strength properties of such material should withstand the strikes more effectively.

For the first time at the conference, an experimental test bench was presented, reported in sufficient detail and described in a peer-reviewed collection. This stand is a really levitating ring rotor with an external metal rim and a stator platform. All main elements of the GPV's levitating part are simulated in reality. However, this is the case when the scale factor is of decisive importance, i.e., the proportions of the dimensions of the GPV ring and the length of the Earth's equator. If we assume that the diameter of the GPV is 2 m and the length of the Earth's equator is 40,075 km (considering the Earth's topography) and the circumference of the levitating part of the described test bench is about 2 m, then the diameter of the test bench rotor with the above proportions shall be 0.1 μm , i.e., 1,000 times thinner than a human hair, taking 100 μm as the average hair thickness. Accordingly, the sizes of magnets, control systems and other elements of the test bench shall be even smaller by an order of magnitude. This elementary calculation shows that the problems of ensuring the rigidity and dynamic stability of the GPV ring as a whole become of decisive importance. The reviewer believes that at the current state of development of means and methods of deformable solids' mechanics, the fundamentals of dynamics and the strength of structures, the availability of computing power and significantly increased qualifications of the creative team led by A. Unitsky, furthermore, considering the GPV's calculations that have already been carried out by the team, the abovementioned problems are solvable in theoretical terms. Practical implementation of the GPV will most likely require clarifying modeling and further improvement of the GPV design elements.

Given the obvious complexity of the practical implementation of the GPV ring, the construction and operation of the equatorial GPV overpass is an equally important task. The developers propose a multifunctional version of the overpass, including the GPV's runway ("launch pad") as well as rapid (up to 200 km/h), high-speed (up to 600 km/h) and hypervelocity (more than 1,000 km/h) transport and logistics complexes providing cargo and passenger traffic along the entire equatorial overpass. It should be noted that from an engineering point of view, the creation of such a multifunctional complex does not seem impossible. Rapid, high-speed and hypervelocity transport systems are already being designed, built or operated in one form or another in a number of countries. Unitsky String Transport (uST), described in certain authoritative monographic publications

and in the reviewed collection, makes its contribution to the creation and operation of such systems. Design and technological solutions for the land sections of the equatorial overpass with a length of 8,944 km (considering the Earth's topography), despite all the difficulties associated with mountainous terrain and variations in the Earth's magnetic and gravitational fields, seem quite convincing at the current stage of development of the GPV's idea.

The proposed inhabited high-rise supports of the GPV takeoff and landing complex, which are essentially skyscraper single-industry towns with a specific residential environment, deserve a separate positive assessment. The technical, environmental and sociopsychological aspects of the construction and operation of such supports and the living conditions in them, set out in the collection, have been planned meticulously and leave no room for objections.

The reviewer believes that despite all deep and comprehensive engineering study of the elements of the GPV takeoff and landing overpass, its oceanic sections seem to be the most vulnerable. Storms, hurricanes, tsunamis, rogue waves, multidirectional currents in the depths of the ocean, movements of geotectonic plates, earthquakes, underwater volcanoes and geysers – this is not a complete list of "surprises" that the World Ocean and the surface part of the atmosphere are "capable of". The work on the improvement of the reliability and stability of the GPV overpass to the abovementioned external influences should be continued. At the very least, it is necessary to create a separate, fundamentally new equatorial weather service that monitors and predicts the development of weather phenomena along the entire length of the equator and determines the optimal weather "gap" for the ascent and descent of the GPV ring.



The materials included in the reviewed collection demonstrate a qualitatively new level of depth and breadth of elaboration of almost the entire range of problems, ideas and projects presented at the previous five conferences.

Traditionally, the conference topics contain works devoted to a set of issues related to long-term human residence in enclosed ecosystems, technologies for growing various plants in EcoCosmoHouse, bioutilization of organic residues, etc. In each of these areas, significant progress as well as an increasing level of elaboration and expansion of real practical experience implementation is noticeable.

The works aimed at political and legal support for the implementation of the GPV and uST projects are very important and well-timed both in general and within the framework

of the international association BRICS+ and also as an important component of rebooting the economy of the Union State of Belarus and Russia.

In conclusion, it should be emphasized that all works included in the collection are well edited, logically and intelligently presented, terminologically correct.

I recommend the collection of articles of the VI International Conference "Non-Rocket Near Space Industrialization: Problems, Ideas, Projects" for publication in the open press in the presented form.



Review by Michael Orloff,

**Doctor of Engineering Sciences, Professor,
General Director and Scientific Supervisor
of the Modern TRIZ Academy,
(Berlin, Germany)**



Dear colleagues, in this review I have focused on the plenary report of A. Unitsky without belittling the importance of other materials provided in the collection. I think that the grounds for my decision are clear from the following.

Part 1.

ENGENIUM. The World as an Engineering Project

In 2010, in the preface to my book "Modern TRIZ", Anatoli Unitsky wrote, "I see it as a great challenge for each of us, readers, to realize through TRIZ and together with TRIZ the beauty and miracle of creating something new – necessary, effective, harmonious, unexpected, amazing and inspiring! The miracle of inventing the future." The same words, with their deepest meaning, I address today to Anatoli's engineering, sociopolitical and philosophical report, which is published in this collection.

I addressed an extensive analysis to the author, and for the accompaniment of the collection, the significance of A. Unitsky's reflections can be formulated more briefly.

1. The fundamental topic raised by the author is the rethinking of the role of engineering in the perspective of human evolution. The result of such rethinking scientist Unitsky sees in the idea of elevation of moral ideal and imperative in the activity of engineering community, in the necessity of engineering transition from relatively neutral status to active organizing and even leading position in relation to the social order.

* Orloff, M. Modern TRIZ / M. Orloff. – New York: Springer, 2012. – 449 p.

Engineering is postulated convincingly to be the leading planetary institute of management based on the fundamental humanitarian values of existence and the goals of just organization of life on Earth, on the paradigm of the unconditional significance of each individual, on the primordial ideas of infinite preservation of human civilization in irreconcilable opposition to eschatological phantasms, on the concept of constructive transformation and further improvement of the world, which is inherent in the profound ideas of socialism, in opposition to the misanthropic and suicidal realities of modern capitalism.



**A. Unitsky's ideas
cannot be disparaged.
The author proves the value
of his concepts by actual
engineering creativity
and by the results
which already reveal the outlines
of his proposed future
for human civilization.**

Reflecting on this topic, the author quite naturally comes to the understanding of the necessity and possibility of reorganizing the world through mastering the engineering approach in predicting and developing all aspects of humankind's unity with nature and space, through systematically and mathematically grounded, morally and aesthetically inspired awareness of the future as a just, humane and eternal prosperity of society in complete contrast to apocalyptic despair, devaluing human life, imposed on society by the apologists of perverted, satanic bigotry.

I encourage readers to join engineer Unitsky's moral and pragmatic ideas and increase their personal contribution to life-affirming activities for the benefit of Earth's civilization.

2. The engineering tasks and directions on which A. Unitsky concentrates his practical activity are also entirely consistent with his philosophical and sociopolitical attitudes. His work and struggle for the embodiment of social ideals postulated by him in real structures and processes are rational and convincing.

Creation of global multifunctional elevated transport is nothing but the development of the fundamental uNet project to achieve real freedom and efficiency in the movement of material objects and people around the planet as well as for the organization of new locations for human habitation, nutrition and healthy lifestyles.

The construction of a space house, designed for a long stay of people in near space, is nothing else than the materialization of the ideas of Russian cosmism, as a constructive fulfillment of the conditions of coevolution of humankind on planet Earth and space.

The author's report and his creative engineering activities together with his colleagues push the horizons of the future vision far and wide: in elevated transport – from today for hundreds of years ahead; in near space – from tomorrow for thousands of years ahead!

3. A. Unitsky's ideas cannot be disparaged. The author proves the value of his concepts by actual engineering creativity and by the results which already reveal the outlines of his proposed future for human civilization.

The miracle of the invention of the future, breaking through many years of searching of the Belarusian scientist and the struggle for his worldview, appears today before our eyes in the form of uPods and string structures, in the form of a giant microcivilization of new humus, in the form of an enclosed ecologically self-regulating and self-healing house, rising from the personal fate of the author, the tragic fate

of our Motherland and parents, from whom their future and the future of all humankind were taken away by betrayal unprecedented in history.

The challenge today is to restore historical justice, to provide life-affirming perspectives for civilization, and to eliminate the suicidal influences of Satanism growing out of inhuman capitalist archaism.

That is why I support Mr. Unitsky's report and the author's efforts to revive fundamental ethical meanings through the development of transport that does not kill, through the creation of humus that will feed all of humanity, through the affirmation of ideas that will save the planet.

In my internet lecture organized on December 5, 2023 by the Belarusian Institute of System Analysis and Information Support of the Scientific and Technical Sphere, I demonstrated on the screen engineer Unitsky's hands immersed in life-giving humus and told the story of how once a paparazzi photographed Sergei Rachmaninoff's hands, with which the composer covered his face to avoid being photographed. However, one brilliant editor published this photo with the caption "Hands that are worth millions". And I said in my lecture about A. Unitsky's hands, "Hands that are worth billions." Today I assert that they are worth much more and more.

Part 2.

Set of Articles Presented at the Conference

With respect and attention I have worked through all the materials of the collection and find the results they present interesting and useful, which convincingly show the continuous progress in engineering and research activities of A. Unitsky's companies in the paradigm that I described in the first part of the review.

Best wishes to the author and his followers!

Review by Alexander Malyarevich,

**Corresponding Member
of the National Academy
of Sciences of Belarus,
Doctor of Physical
and Mathematical Sciences,
Professor**



The idea of non-rocket near space industrialization has been being discussed for years. When I heard about this concept for the first time, I was stunned by its uniqueness and shocked by the courage and originality of approaches. In terms of physics such a project can really be implemented, although it will obviously take decades of hard work.

I appreciate the possibility to learn more about the works by Belarusian scientists and representatives of the international science and engineering community which were presented at the VI International Scientific and Technical Conference.

The articles of the collection cover different areas that should be investigated in order to get close to practical exploration of near space by alternative way. The following topics are among them: analysis of technical aspects of the General Planetary Vehicle (GPV) creation, the GPV takeoff and landing complex on the ocean, anti-meteoroid protection of the GPV, technology for construction of the GPV land sections, methods of crop cultivation in near space, application of legal norms to the GPV construction and operation, etc.

This collection just like the materials of the previous conferences contains variety of ways to implement the most ambitious ideas. Thus, there are new principles of organization of people's life on Earth, in particular, settlements along the supports of the GPV overpass. In general, the main concept implies transition from crowded megacities to horizontal residential complexes providing healthy and comfortable conditions for life without having any impact on the environment.



**The work by A. Unitsky
is a systemic scientific justification
of an alternative way
of the civilization development
for its successful, healthy
and prosperous existence.
This task is economically
feasible just now.**

There is no doubt that physicists, chemists, mathematicians, engineers and others concerning about the future of humanity are interested in the results achieved. But, to my opinion, the main part of the presented collection is a comprehensive research by Anatoli Unitsky, "INGENIUM". This is a summary analysis of millennial history of the human civilization development and its interaction with nature. The passed path is now clear and understood to many. The prospect of the near future is sad and even tragic. It is known that in recent decades the environmental problem has worsened, herewith, the proposed solutions and their results are disappointing. Under these conditions

the ideas by engineer Unitsky are extremely relevant. The author of the "INGENIUM" report sets out a vision of the transformations in a reasoned and clear manner, these actions are required to save humanity and planet Earth – its cradle and home.

The work by A. Unitsky is a systemic scientific justification of an alternative way of the civilization development for its successful, healthy and prosperous existence. This task is economically feasible just now. Large states (USA, China, Russia, etc.) collectively spend much more financial and material resources on so-called operating expenses

(transport, industrial and agricultural production, military purposes). That is why implementation of the great idea – the non-rocket industrialization of near-space – first of all requires political will and interest as well as the ability to negotiate and work together.

I think that the materials of the VI International Scientific and Technical Conference "Non-Rocket Near Space Industrialization: Problems, Ideas, Projects" which are presented in the collection will be useful to all responsive and intelligent people.





Dear readers,

The present collection was prepared based on the materials of the VI International Scientific and Technical Conference "Non-Rocket Near Space Industrialization: Problems, Ideas, Projects", which was held on October 7-8, 2023 in Maryina Gorka (Republic of Belarus).

This edition covers the results of a year's activity of scientists, designers, engineers, who work on the implementation of the global uSpace geocosmic program. Each of the projects presented in the collection is being realized and tested at proving grounds in Russia, Belarus and the United Arab Emirates. Near space industrialization, transfer of harmful industry to near-Earth orbit is the only possible way to preserve the planet's ecology as well as to solve socio-economic problems of our time, designed to ensure a decent future for upcoming generations. Only by carrying out industrial exploration of the near space, we will be able to make a full-scale expansion into space, open access to inexhaustible resources for human civilization and create a basis for the development of science and technology.

The uSpace program brings together leading developments in a wide range of scientific disciplines that describe various aspects of human presence outside Earth, unique research and know-how in the field of space, innovative modes of transport, industry, biotechnology, sociology and philosophy, which are of interest and value to the scientific community worldwide.

The global nature of the program implies the possibility of active participation of professionals from all spheres and directions, provides an efficient communication for joint creative activity for the benefit of all humankind.

Every day we are bringing the most ambitious space exploration project closer to implementation. You can join the uSpace program now.



 aet.space



 Facebook



 YouTube

Please send your feedback, wishes and suggestions to the following address: conf@ecospace.org.

Conference Organizing Committee,
Editorial Board of the Collection of the Conference Materials

Non-Rocket Near Space Industrialization: Problems, Ideas, Projects: Collection of Articles of the VI International Scientific and Technical Conference, Maryina Gorka, Oct. 7–8, 2023 / Astroengineering Technologies LLC, Unitsky String Technologies Inc.; ed. A. Unitsky. – Minsk: StroyMediaProject, 2024. – 476 p.
ISBN 978-985-7296-39-2.

The materials of the collection reflect the subject matter and content of the reports presented within the framework of the VI International Scientific and Technical Conference "Non-Rocket Near Space Industrialization: Problems, Ideas, Projects". During the 2023 conference, the ways of solving global problems of our time by geocosmic means were analyzed; the principles of transport and infrastructure geocosmic complex design were announced; the technology and mechanization construction of land and oceanic sections of the General Planetary Vehicle equatorial overpass as well as options for anti-meteoroid protection of its body were considered; the features of providing comfortable living in space settlements were studied; social, political and economic issues regarding near space industrialization were discussed.

The collection contains the works of engineers, inventors, scientists, representatives of public organizations of Belarus as well as countries of near and far abroad.

The publication is intended for specialists in the field of transport communications, space research, astrophysics, biotechnology as well as for fellows of research institutes, teachers and students of educational institutions.

Scientific Publication

NON-ROCKET NEAR SPACE INDUSTRIALIZATION: PROBLEMS, IDEAS, PROJECTS

Collection of Articles of the VI International Scientific and Technical Conference
(October 7–8, 2023, Maryina Gorka)

Editorial Board

Chief Editor: A. Unitsky, Dr. Ph. Inf. Tech. (Transport); Managing Editor: D. Isaev; Coordinator: I. Lobazova, Ph.D. Chem. Sc.;
Section Editors: S. Artyushevsky; M. Tsyrlin, Ph.D. Eng. Sc.; N. Zyl; A. Kazakevich; E. Petrov; Brand Consultant: O. Kotishevskaya;
Editor: L. Budivskaya; Scientific Consultants: A. Klimkov, Ph.D. Econ. Sc.; V. Garanin, Ph.D. Eng. Sc.; Executive Secretary: D. Romanuk

Reviewers of articles

B. Samarkhodzhaev, Dr. of Law, Supreme School of Judges (Uzbekistan); S. Nevsky, Dr. Eng. Sc., Siberian State Industrial University (Russia);
E. Kudrina, Dr. Eng. Sc., Belarusian State University of Transport; M. Petukhov, Ph.D. Eng. Sc., Belarusian State Economic University; A. Mazanik,
Ph.D. Arch., Belarusian National Technical University; O. Pantyukhov, Ph.D. Eng. Sc., Belarusian State University of Transport; R. Chernin, Ph.D. Eng. Sc.,
Belarusian State University of Transport; S. Melnikov, Ph.D. Eng. Sc., V.A. Belyi Metal-Polymer Research Institute of National Academy of Sciences
of Belarus; V. Rapovets, Ph.D. Eng. Sc., Belarusian State Technological University; V. Lukash, Ph.D. Eng. Sc., Belarusian State Technological University;
Yu. Lipai, Ph.D. Chem. Sc., Institute of General and Inorganic Chemistry of the National Academy of Sciences of Belarus; V. Skorobogatova, Ph.D. in Law,
Institute of International Law and Justice of Moscow State Linguistic University; E. Laevskaya, Ph.D. Eng. Sc., Institute of General and Inorganic
Chemistry of the National Academy of Sciences of Belarus; D. Romanenko, Ph.D. Eng. Sc., Belarusian State Technological University; F. Suboch,
Ph.D. Eng. Sc., Institute of System Research in Agroindustrial Complex of the National Academy of Sciences of Belarus; Yu. Sorokin, Ph.D. Eng. Sc.,
UVR LLC (Belarus); I. Kovalchuk, Ph.D. Eng. Sc., Higher Colleges of Technology (UAE); N. Zenchuk, Ph.D. Eng. Sc., Belarusian State University;
V. Romanovsky, Ph.D. Eng. Sc., Research Center "Structural Ceramic Nanomaterials" of University of Science and Technology MISIS (Russia);
O. Doroshchuk, Ph.D. Biol. Sc., Belarusian Institute for System Analysis and Information Support of the Scientific and Technical Sphere;
A. Khudaiberdieva, Ph.D. in Law, B2B B2C B2G Service LLC (Uzbekistan)

Reviewers of the collection

Yu. Pleskachevsky, Corresponding Member of the National Academy of Sciences of Belarus, Dr. Eng. Sc., Professor,
Honored Scientist of the Republic of Belarus; M. Orloff, Dr. Eng. Sc., Professor, General Director and Scientific Supervisor of the Modern TRIZ
Academy (Germany); A. Malyarevich, Corresponding Member of the National Academy of Sciences of Belarus, Dr. Phys.-Math. Sc., Professor

Editors, Proofreaders: L. Budivskaya, T. Linevich, K. Yakovleva

Translators: Yu. Grinevich, V. Gurinovich, V. Vasilevich, M. Polkanov, M. Vishnevskaya

Computer layout: I. Lud, N. Gorbunova, V. Bespalova

Cover design: E. Skorikova

Visualizations and illustrations: A. Pikta, V. Kuzmich, A. Semak, S. Shanhin, M. Siry, O. Bykova, E. Skorikova, N. Gorbunova

The authors of the published articles are responsible for the accuracy of the information provided in them.

Materials from open internet sources were used in the process of working on the publication.

Signed to the print on Aug/07/2024. Format 60 × 84 1/8. Enamel paper.

Offset printing. Conventional printed sheets 55.34. Circulation 300 copies. Order 735.

Publisher and printing execution: State enterprise "StroyMediaProject".

Certificate of state registration of publisher, manufacturer, distributor of printed publications:

No. 1/43 of Oct/03/2013, No. 2/42 of Feb/13/2014.

13/61 V. Khoruzhey Str., Minsk, 220123.

ISBN 978-985-7296-39-2



9 789857 296392

UDC 629.78

ISBN 978-985-7296-39-2

© Astroengineering Technologies LLC, 2024

© Unitsky String Technologies Inc., 2024

© A. Unitsky, 2024

© Design format. State enterprise "StroyMediaProject", 2024